

Atención a la diversidad

Material fotocopiable



Proyecto didáctico

Equipo de Educación Infantil de Ediciones SM

Revisión pedagógica y coordinación editorial

Elena Correa, Cristina Ulloa

Ilustración

Cristina Pérez

Diseño y maquetación

Equipo SM

Dirección editorial

Francis Berdugo

© Ediciones SM

www.yoquieroaprobar.es

ÍNDICE



ÍNDICE POR UNIDADES

Unidad 1: 4, 5, 6, 7, 8, 9

Unidad 2: 10, 11, 12, 13, 14

Unidad 3: 15, 16, 17, 18, 19

Unidad 4: 20, 21, 22, 23, 24, 25, 26, 27, 28, 29

Unidad 5: 30, 31, 32, 33, 34, 35, 36

Unidad 6: 37, 38, 39, 40, 41, 42

Unidad 7: 43, 44, 45

Unidad 8: 46, 47, 48, 49, 50, 51, 52, 53

Unidad 9: 54, 55, 56, 57, 58, 59, 60, 61, 62, 63

ÍNDICE POR CONTENIDOS

Medida

- Más grande / más pequeño: 9
- Grande, mediano, pequeño: 21
- Lleno/vacío: 16
- Ligero/pesado: 41
- Más alto que / más bajo que: 53

Números

- Número 1: 4
- Número 2: 7
- Número 3: 11
- Número 4: 20, 22, 25
- Número 5: 33, 35, 45
- Número 6: 50, 51, 54
- Número 7: 63
- Números del 1 al 3: 14, 25
- Números del 1 al 4: 27, 28, 29, 39
- Números del 1 al 5: 37
- Números del 1 al 6: 57
- Números 4, 5 y 6: 59
- Ordinales (1.º y último): 17
- Ordinales (1.º, 2.º y 3.º): 31

Operaciones

- Sumas: 43, 48, 56, 61

Cuantificación

- Muchos/pocos: 6
- Todos/algunos: 12
- Ninguno: 17
- Tantos como: 36
- Más que / menos que: 40, 42

Resolución de problemas

- Tabla de doble entrada: 21
- Reconocimiento de propiedades: no es / sí es: 13, 55

Series

- Series con dos elementos: 24
- Series con dos y tres elementos: 47

Conceptos espaciales

- Cerca/lejos: 32
- A un lado / a otro lado: 26
- De frente / de espaldas: 39
- Alrededor: 40
- Entre: 46
- Izquierda/derecha: 60

Conceptos temporales

- Mañana/tarde/noche: 31

Geometría

- El rectángulo: 13
- La esfera: 15
- Líneas rectas / líneas curvas: 16

Capacidades

- Atención: 5, 10, 18, 30, 45, 57
- Percepción: 8, 52, 62
- Memoria: 58
- Pensamiento creativo: 15, 19, 38, 44
- Relaciones lógicas: 13, 21, 23, 30, 34, 49, 55

- Repasar y completar las grafías del 1.
- Unir el número 1 con la imagen que corresponde y colorearla.

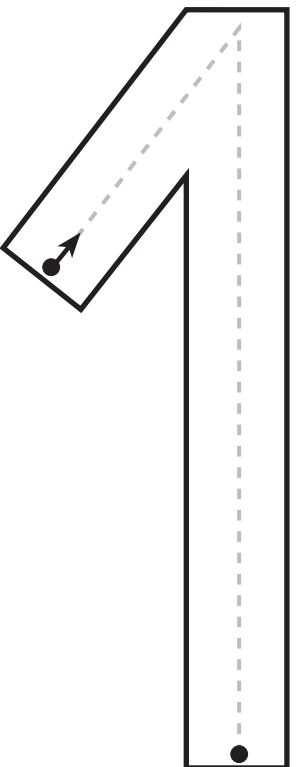
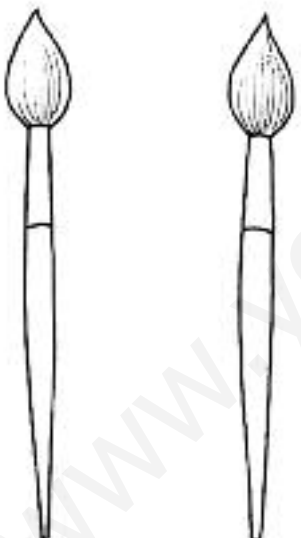
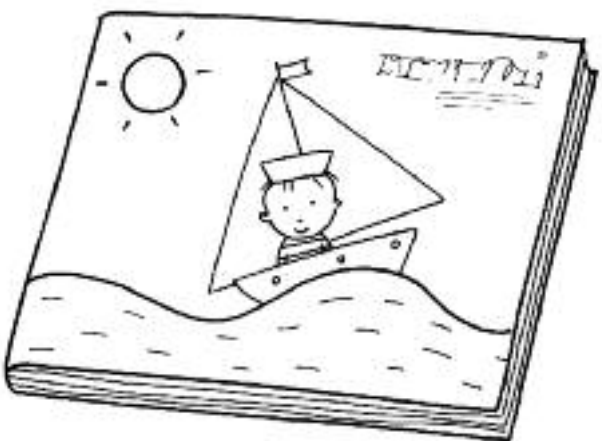
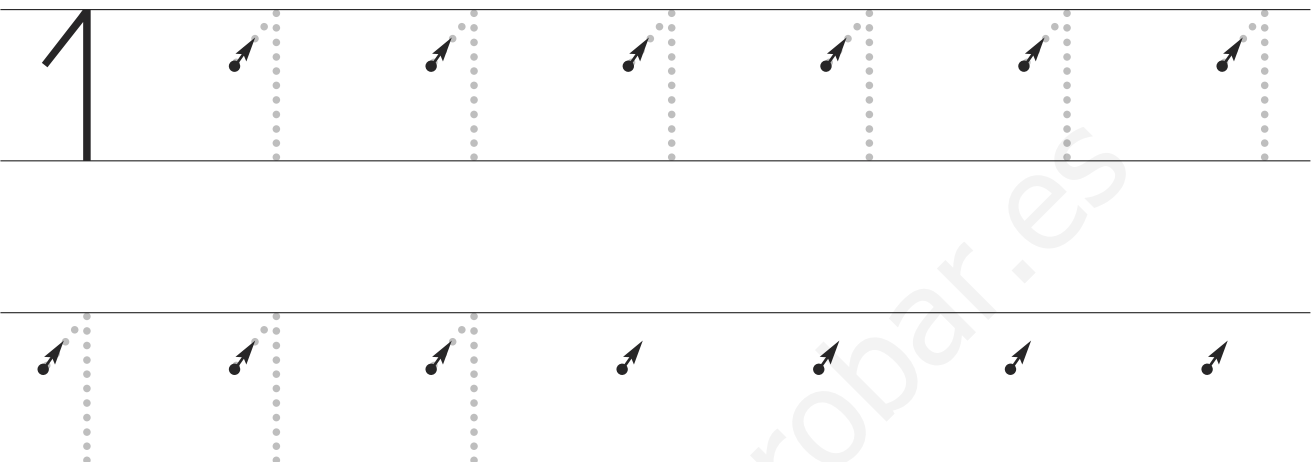

- Rodear el dibujo que es igual al modelo.

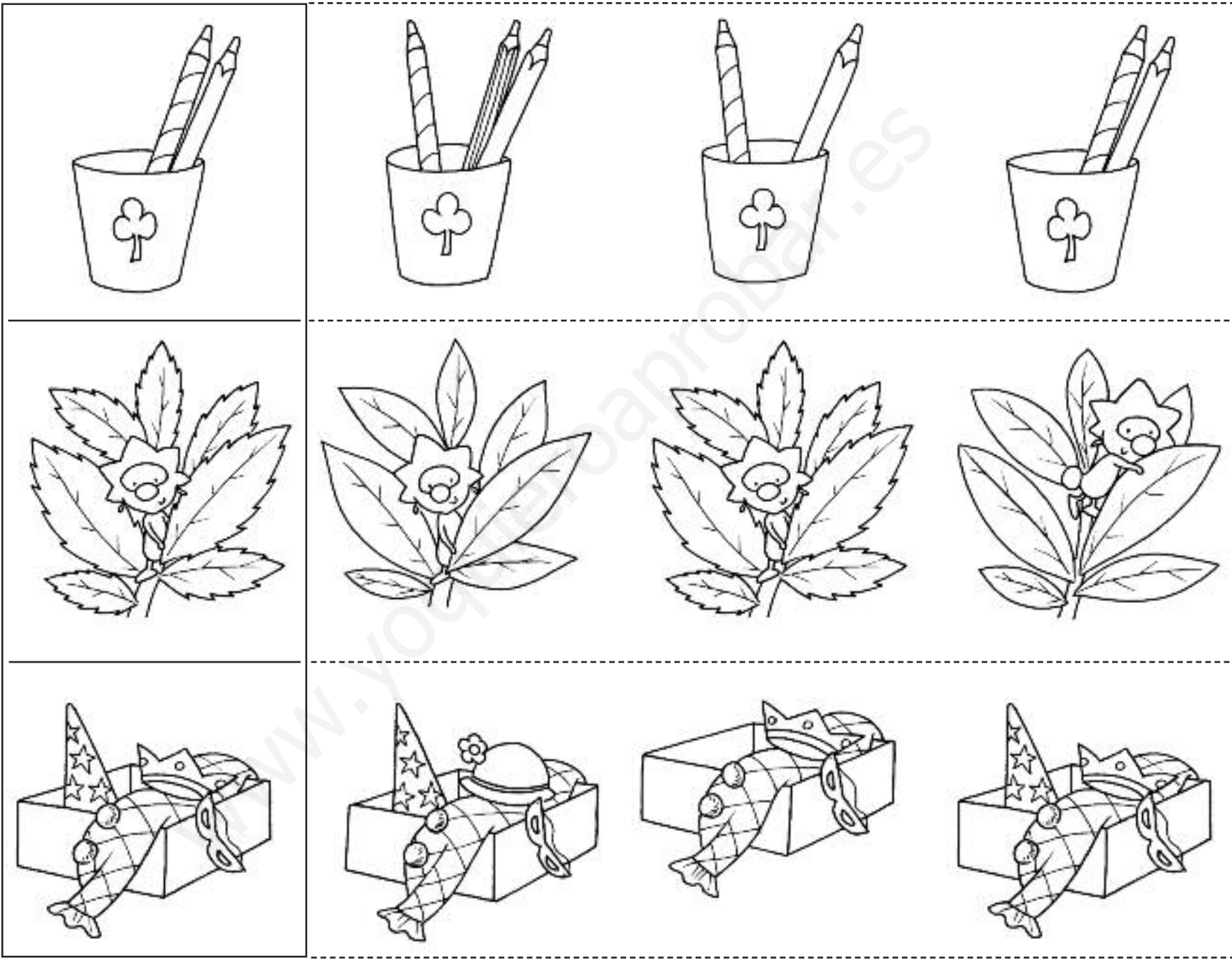

- Colorear la estantería que tiene muchos cuentos y rodear la caja que tiene pocas pinturas.

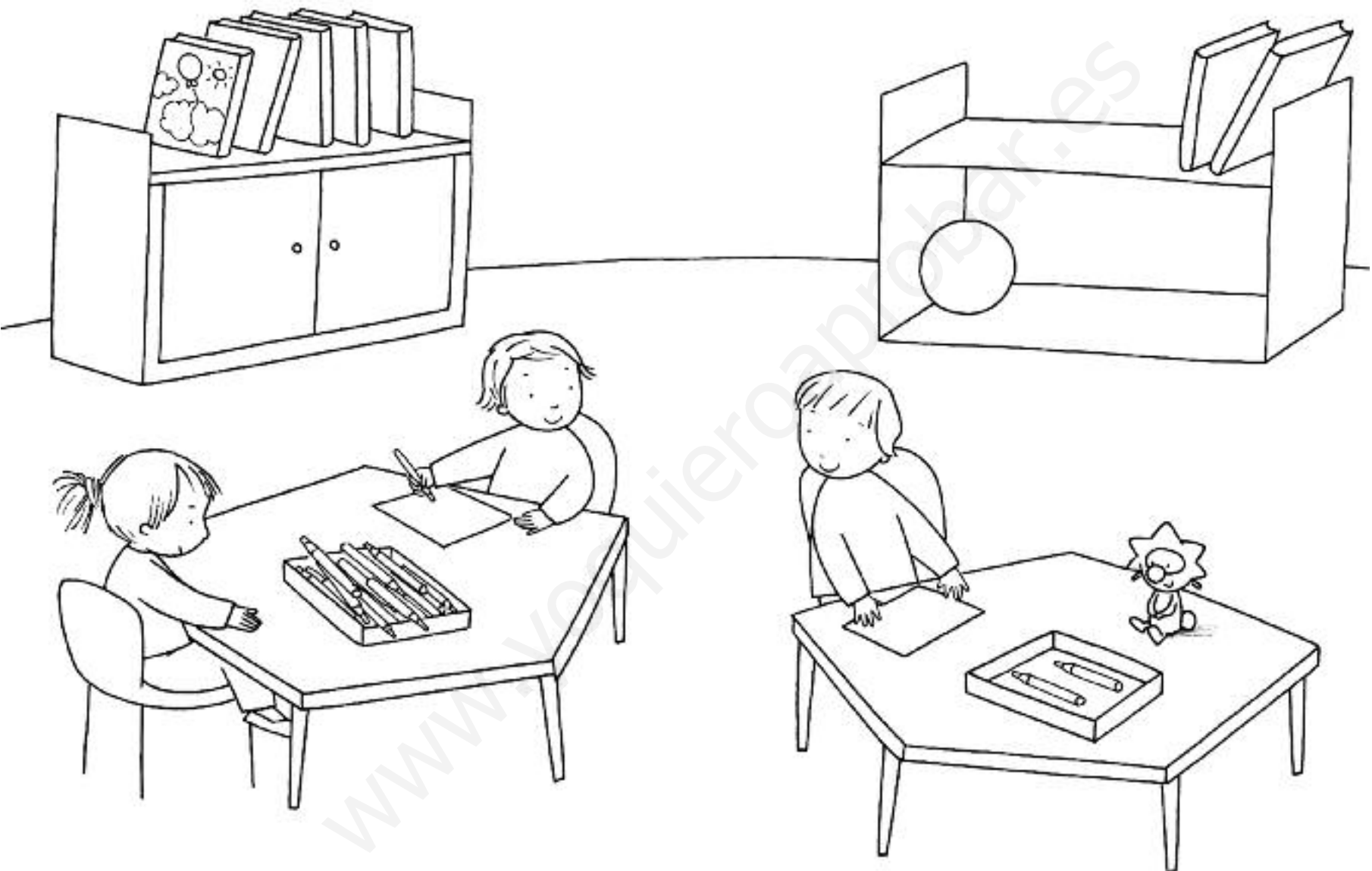

- Repasar y completar las grafías del 2.
- Dibujar dos caminos diferentes que lleguen al colegio.

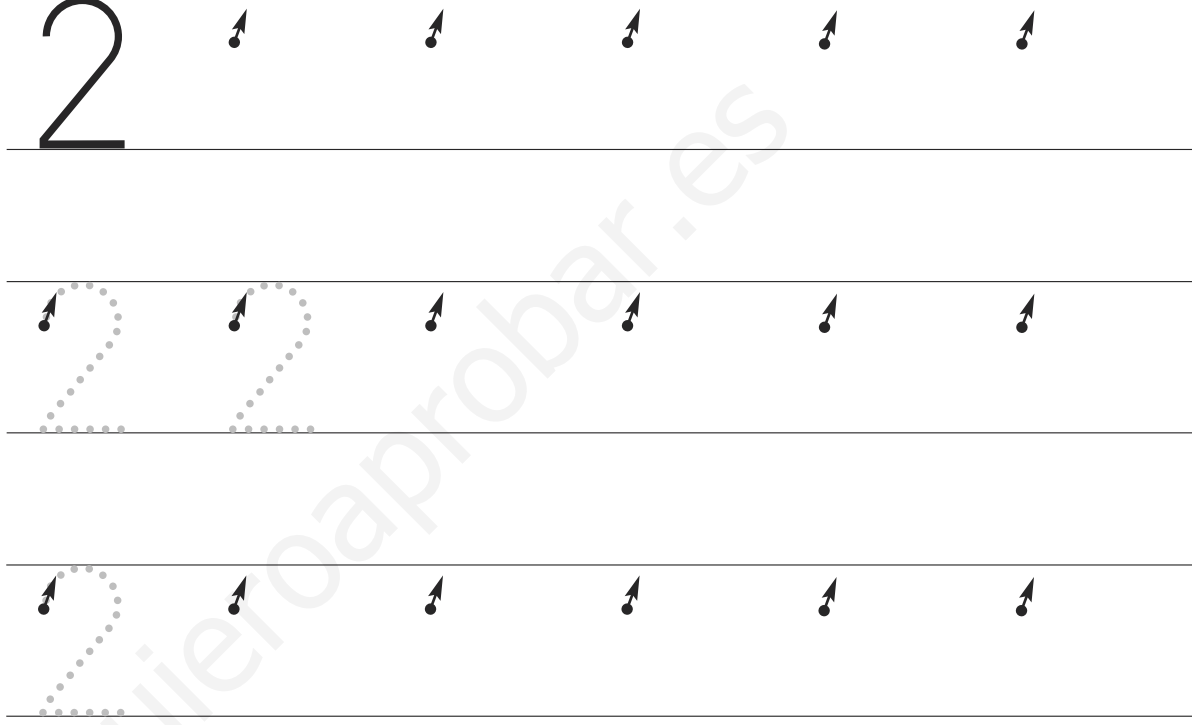
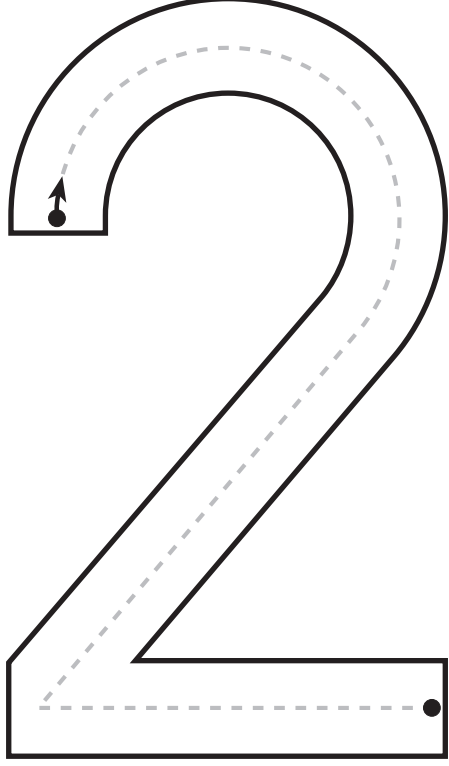



- Completar las figuras y colorearlas.

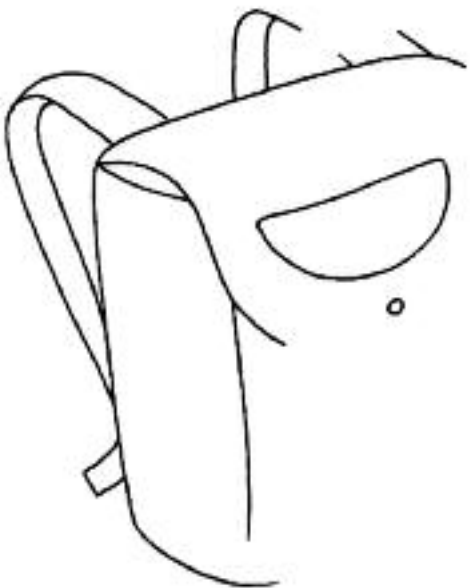

- Colorear los elementos que son más grandes que el colemián y rodear los que son más pequeños.

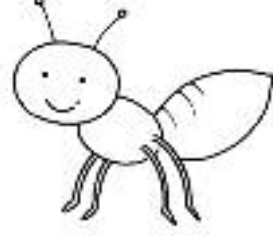
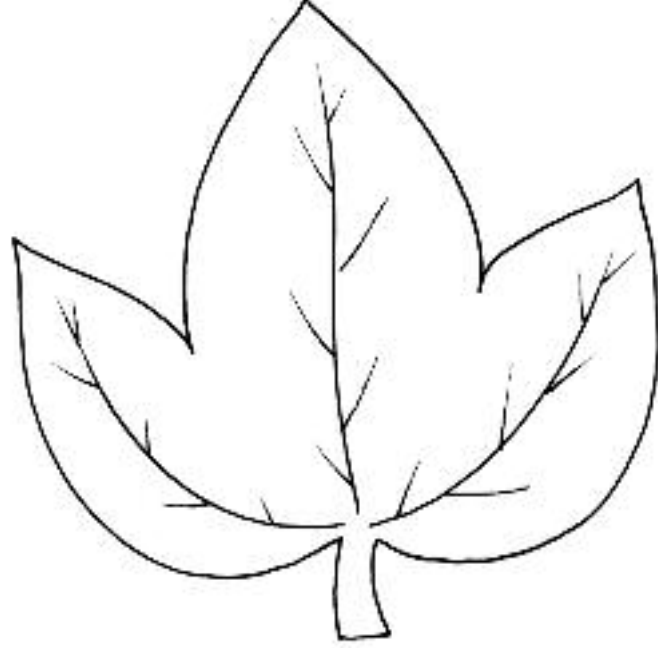
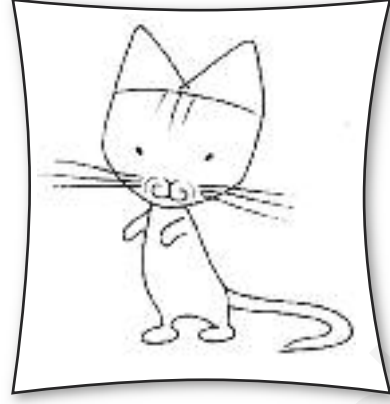

- Seguir las líneas y dibujar cada una de las figuras en el lugar que corresponde.

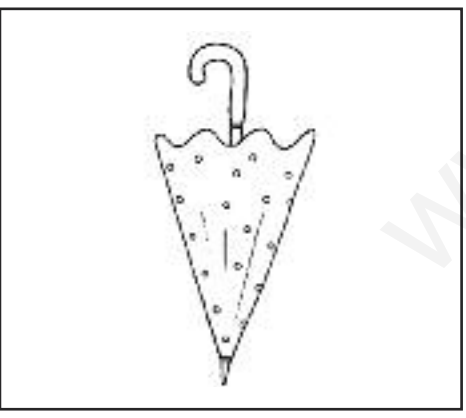
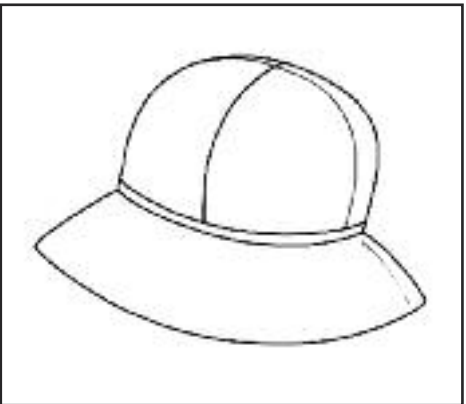
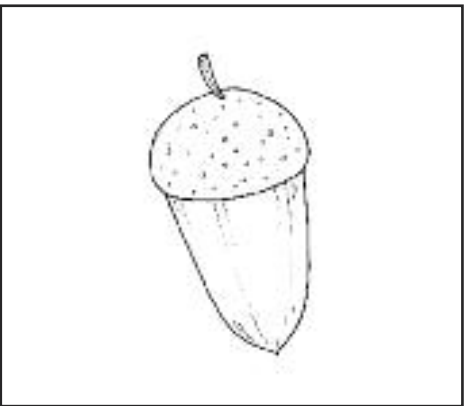
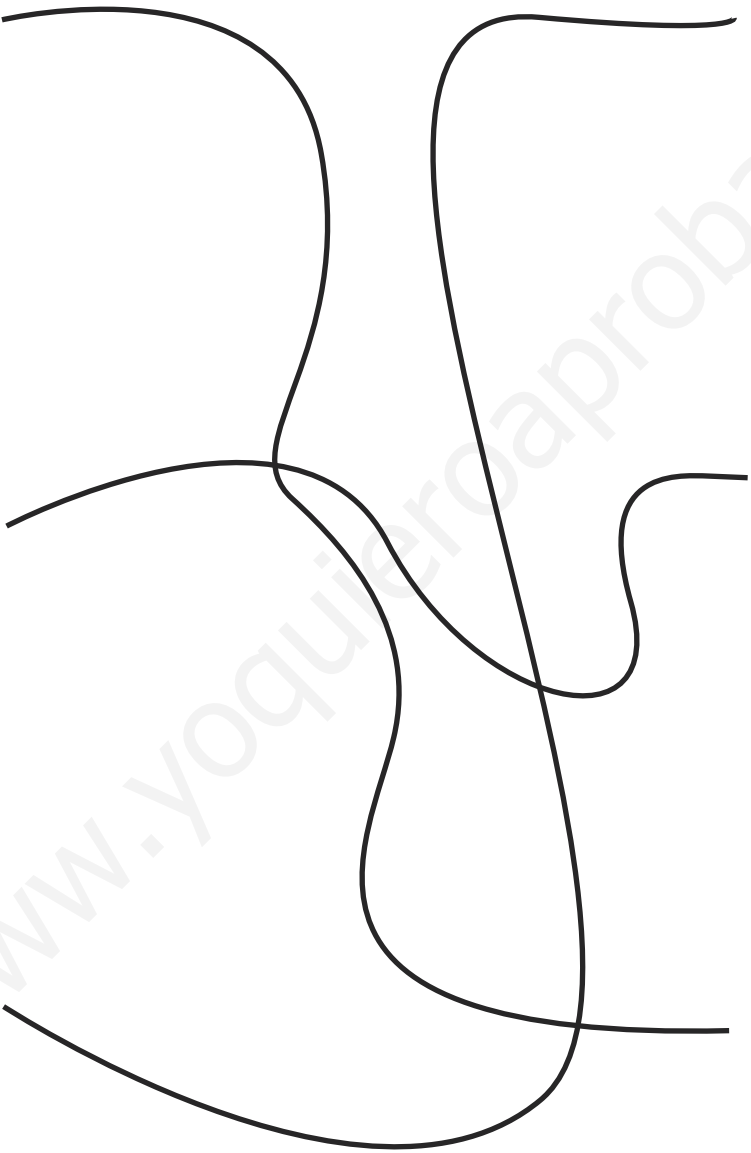
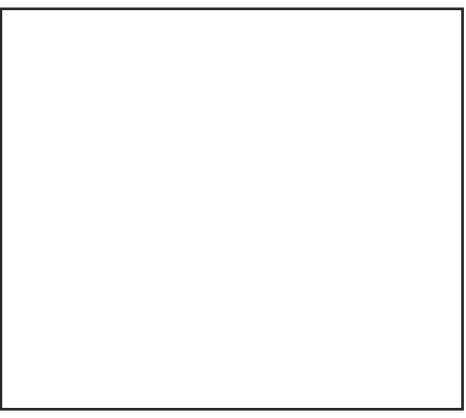



- Repasar y completar las grafías del 3.
- Pegar tres hojas de otoño.

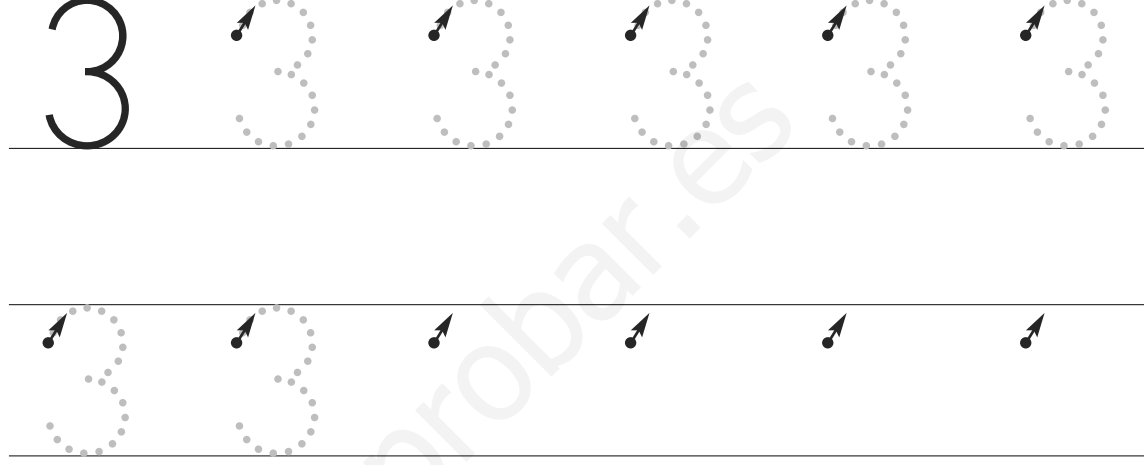
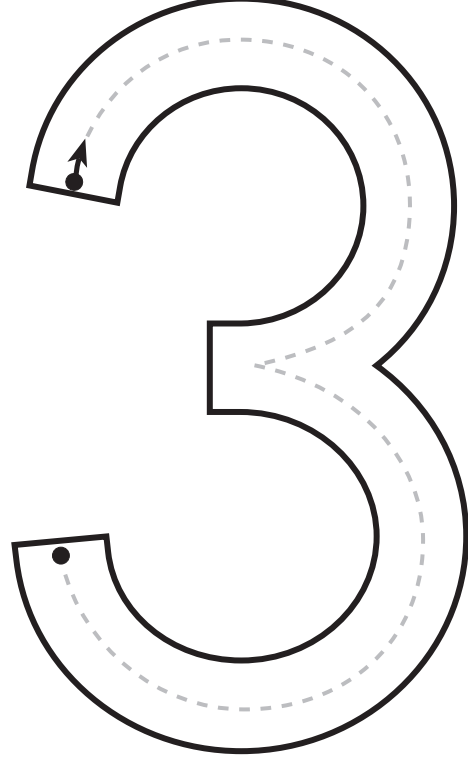

- Dibujar algunos sapos en la charca.
- Colorear todos los sapos.

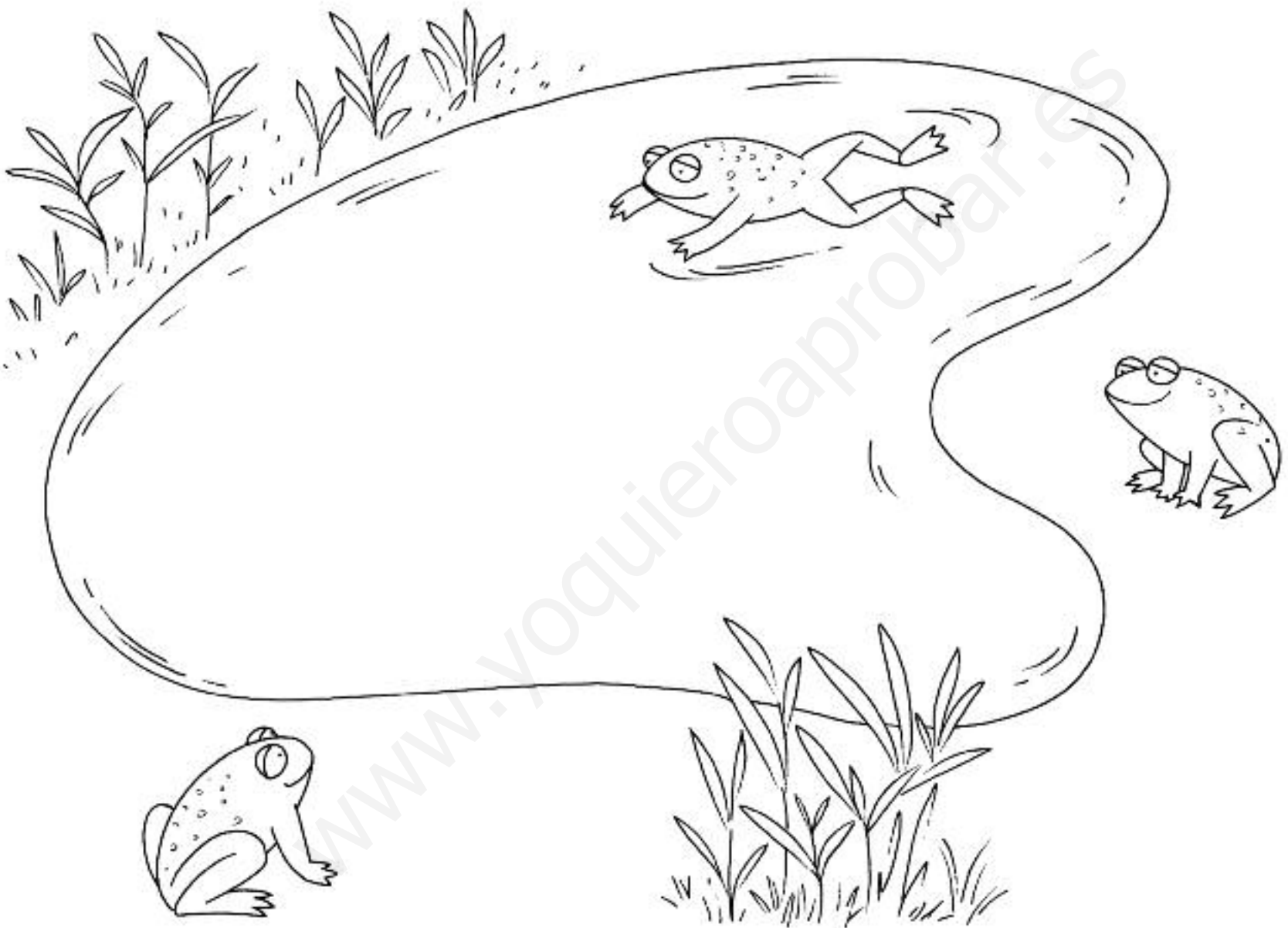



- Tachar las figuras que no son rectángulos. Colorear los rectángulos que son grandes.

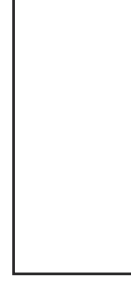
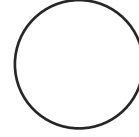
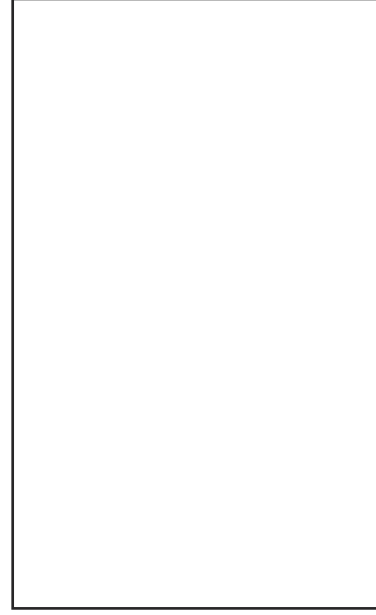
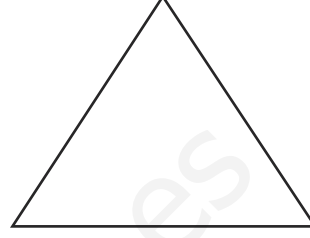
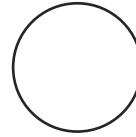
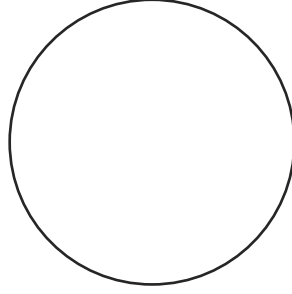
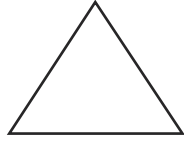

www.yoquieroaprobar.es



UNIDAD 2

- Repasar los números.
- Unir cada número con la imagen correspondiente.

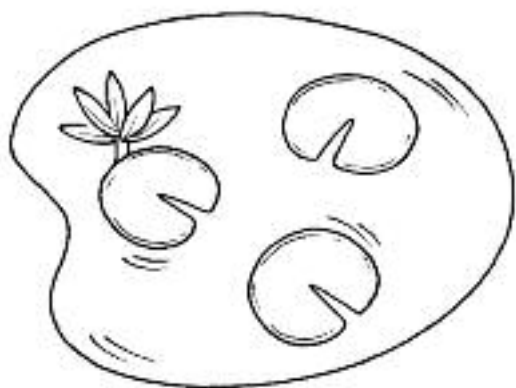
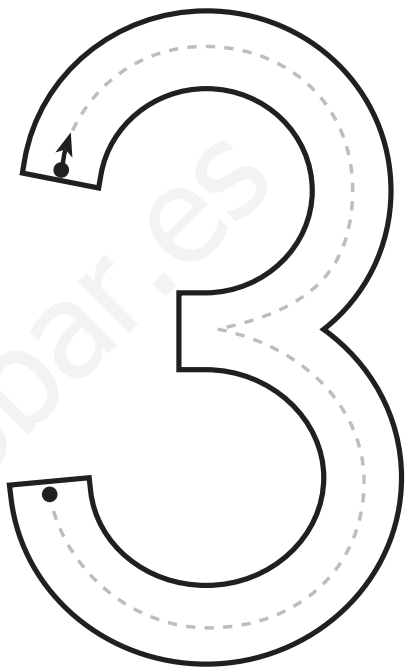
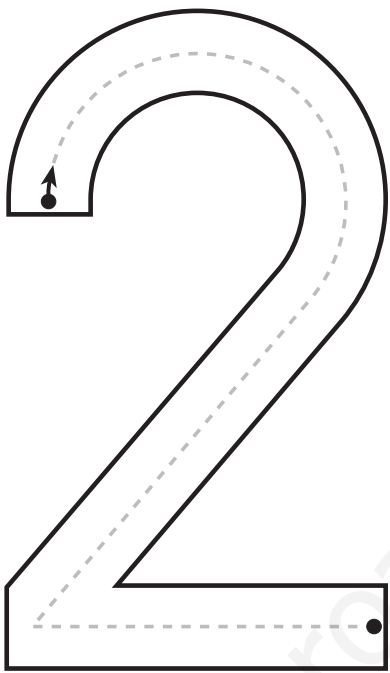
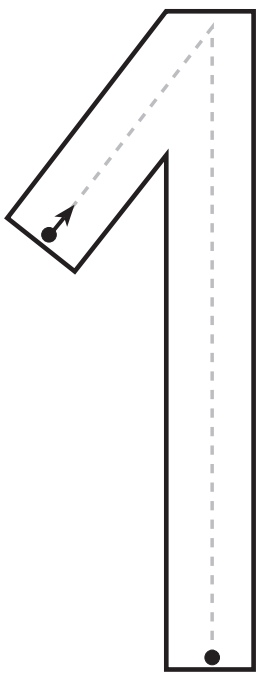



- Colorear los elementos que tienen forma de esfera.
- Imaginar para qué personas puede ser cada regalo y dibujarlas.

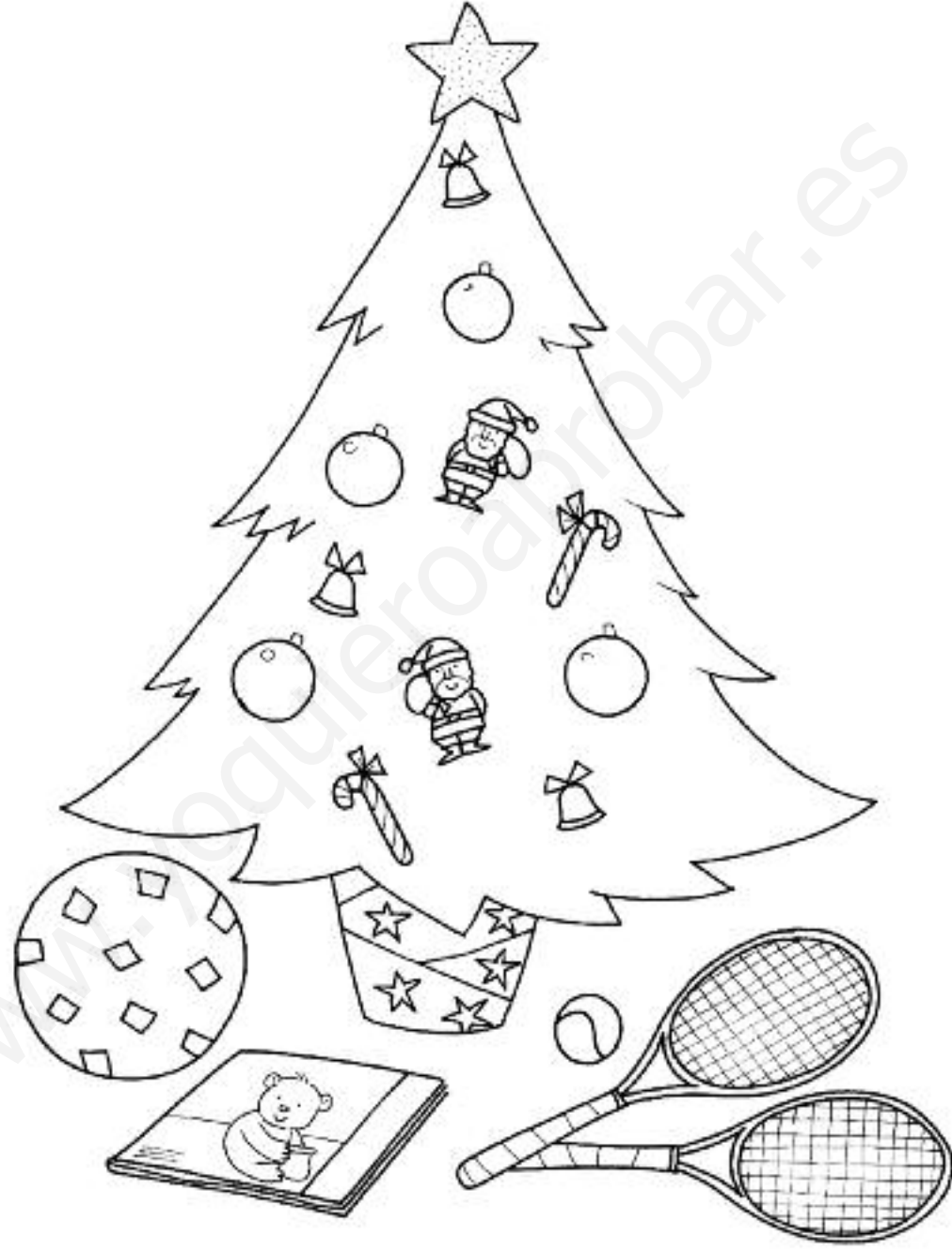



- Decorar el cántaro que está lleno y pegar un gomet en el que está vacío.
- Marcar las líneas rectas de azul y las líneas curvas de rojo.

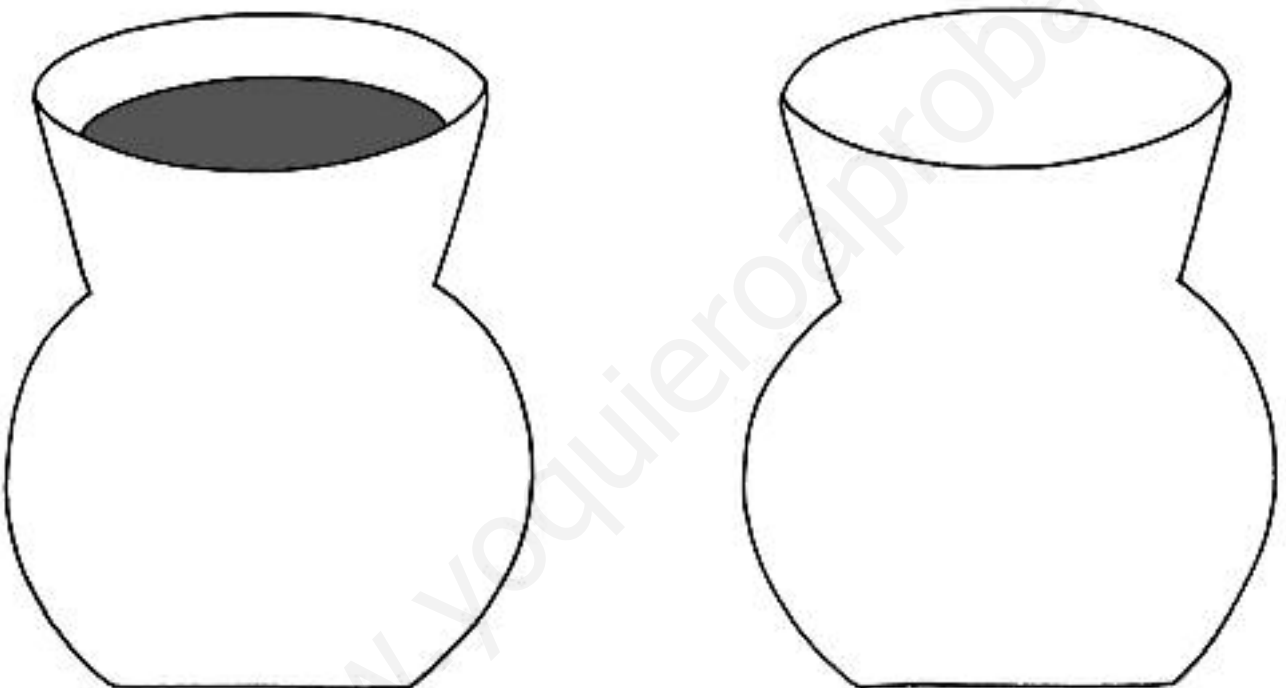

- Colorear al pastorcillo que va el primero y rodear al que va el último.
- Dibujar un animal en el que no lleva ninguna oveja.



- Completar los elementos que faltan en la tarjeta de Navidad siguiendo el modelo.

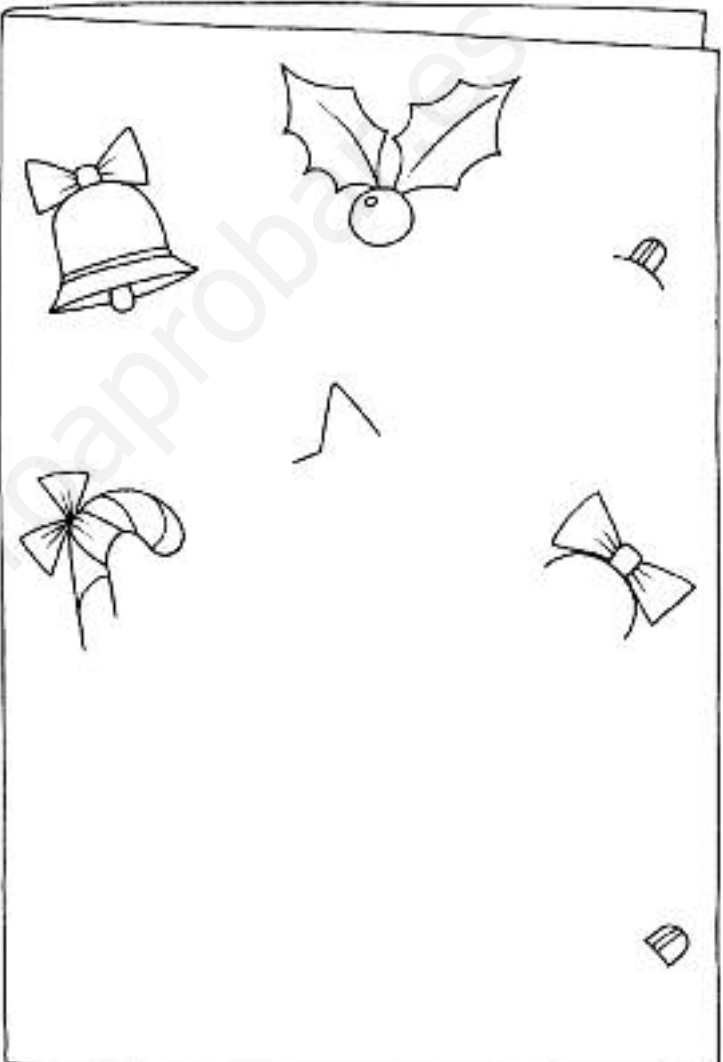

- Dibujar lo que puede contener cada paquete.

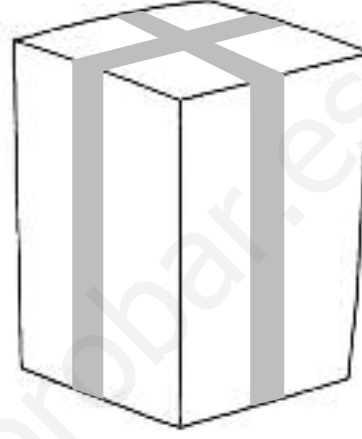
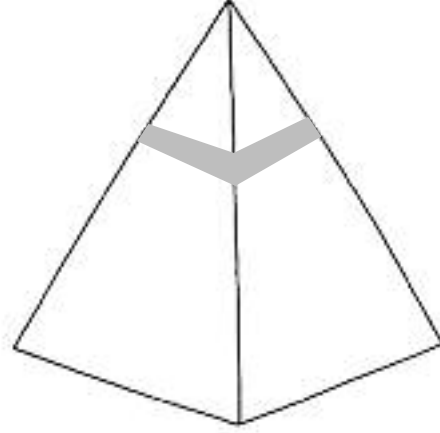
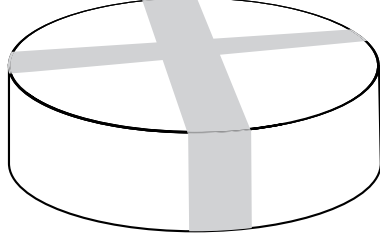
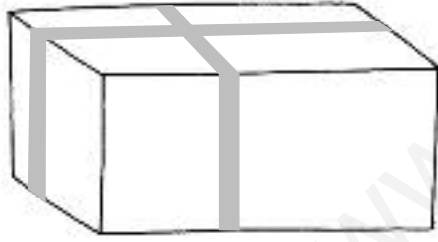

- Repasar el número 4.
- Unir cuatro prendas de invierno con la niña.

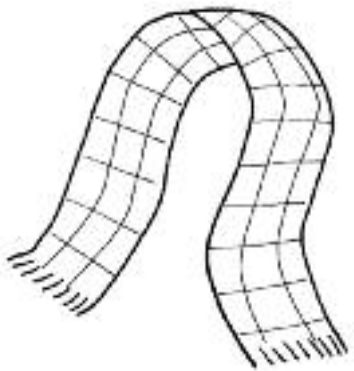
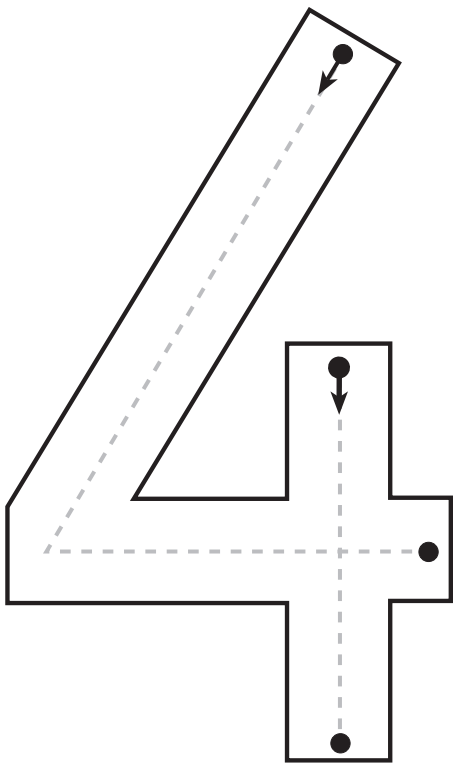

- Dibujar las casas con el tamaño que corresponde en cada casilla para completar la tabla de doble entrada.



- Repasar y completar las grafías del 4.
- Colorear cuatro ventanas del edificio.

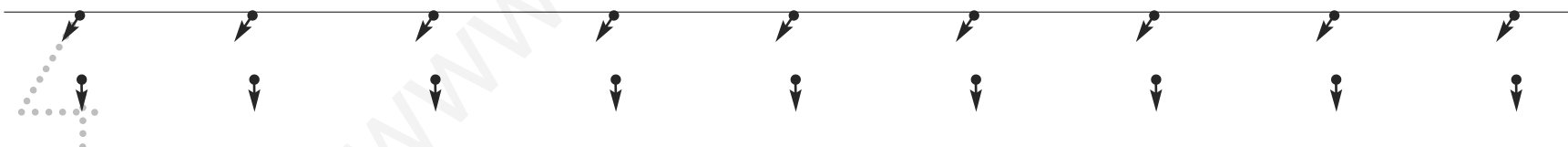
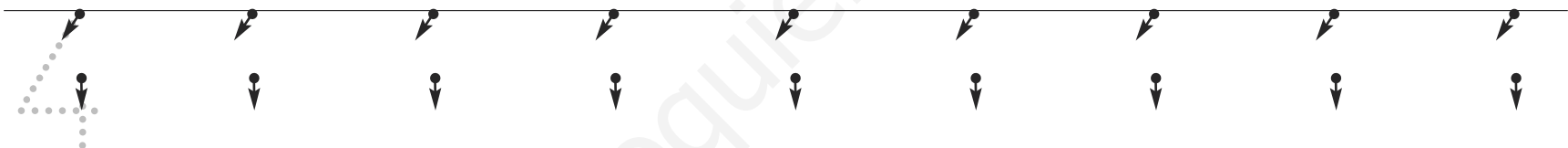
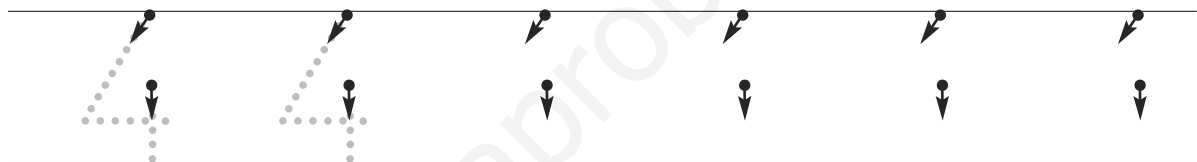
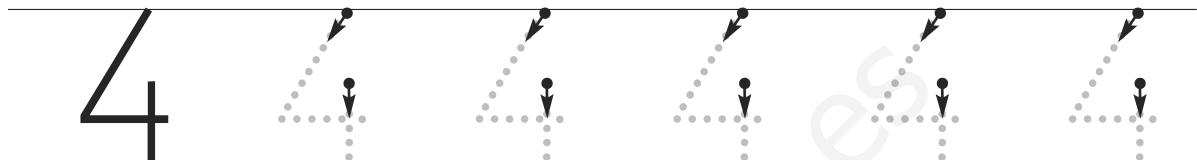

- Tachar en cada fila el objeto que no corresponde.

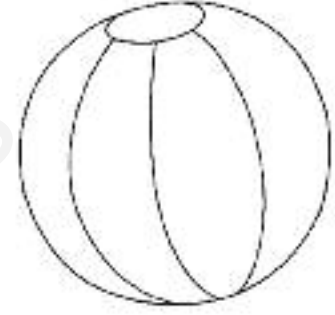
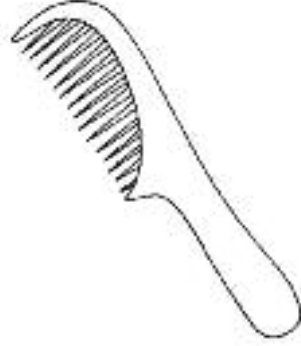
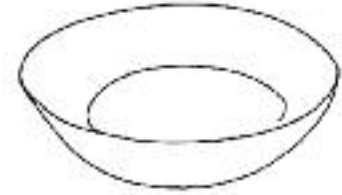
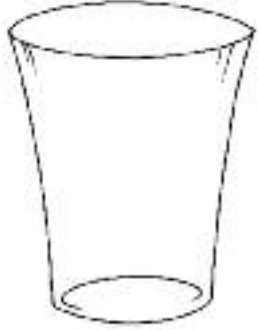
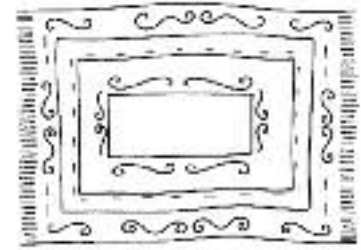
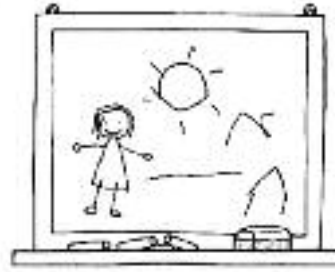

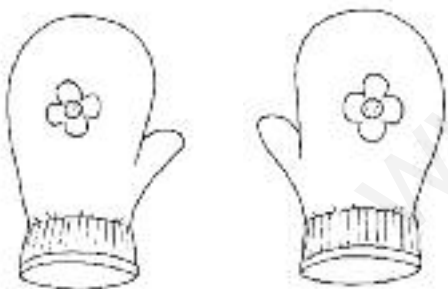
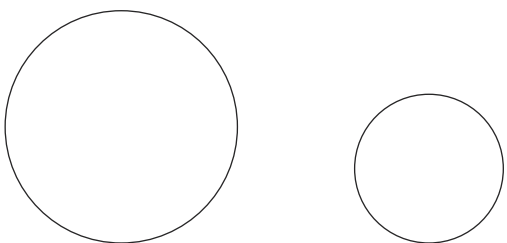
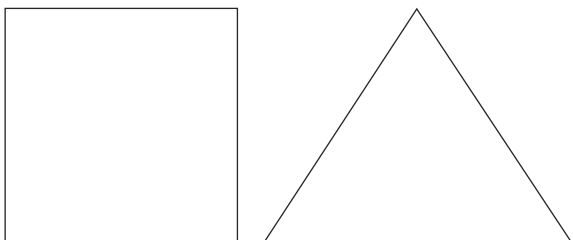

- Agrupar los trineos de cuatro en cuatro y colorear los de cada grupo del mismo color.
- Repasar las grafías del 4.

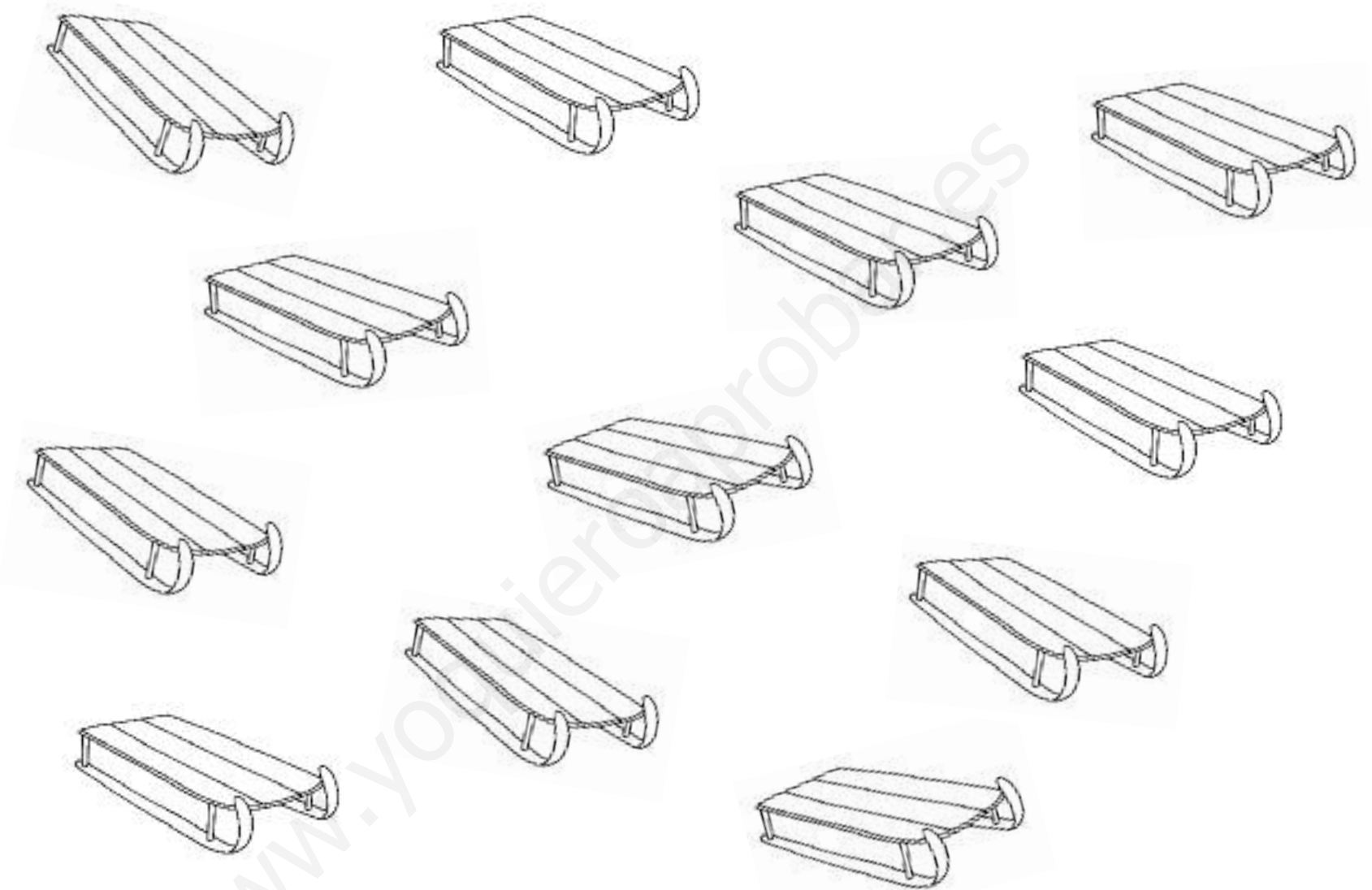
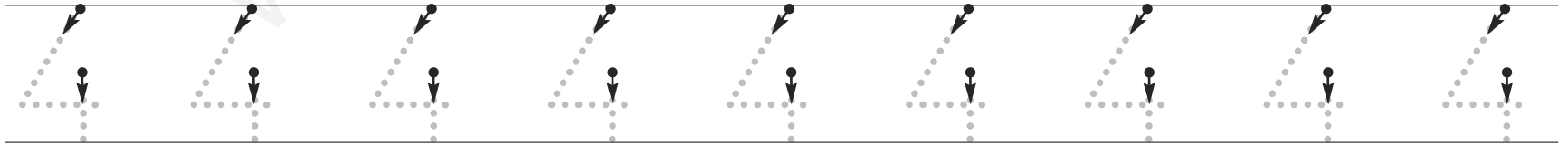

- Dibujar un muñeco de nieve a un lado de la casa y un árbol al otro lado de la casa.



- Repasar los números.
- Unir cada número con la cantidad que representa.

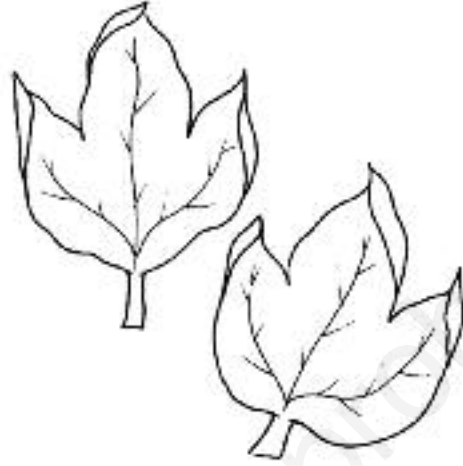
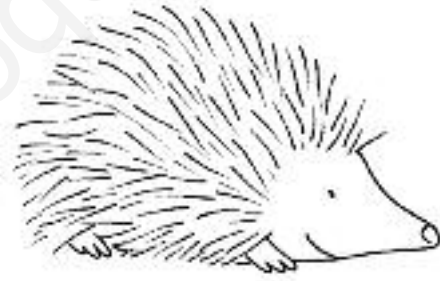
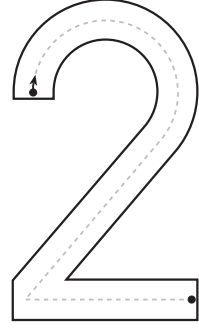
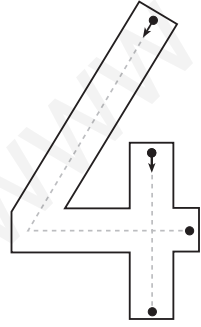
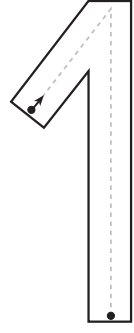



- Repasar las grafías.
- Completar cada grupo con los elementos que faltan.

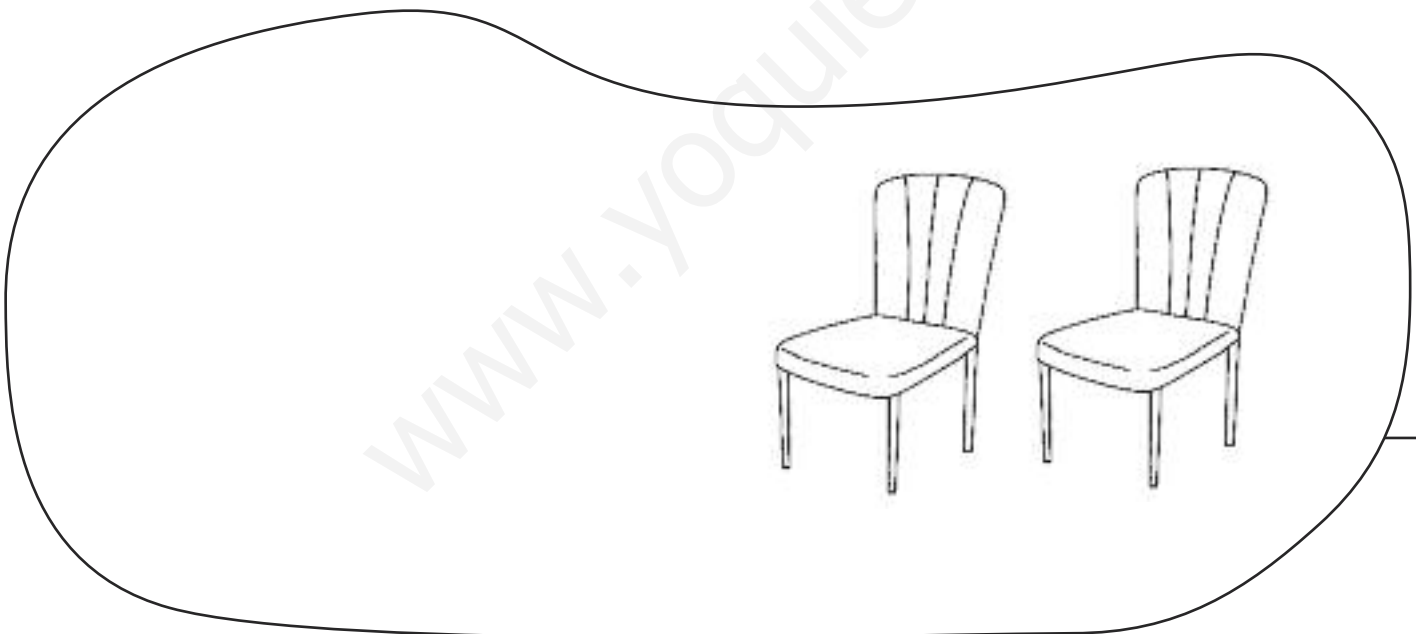
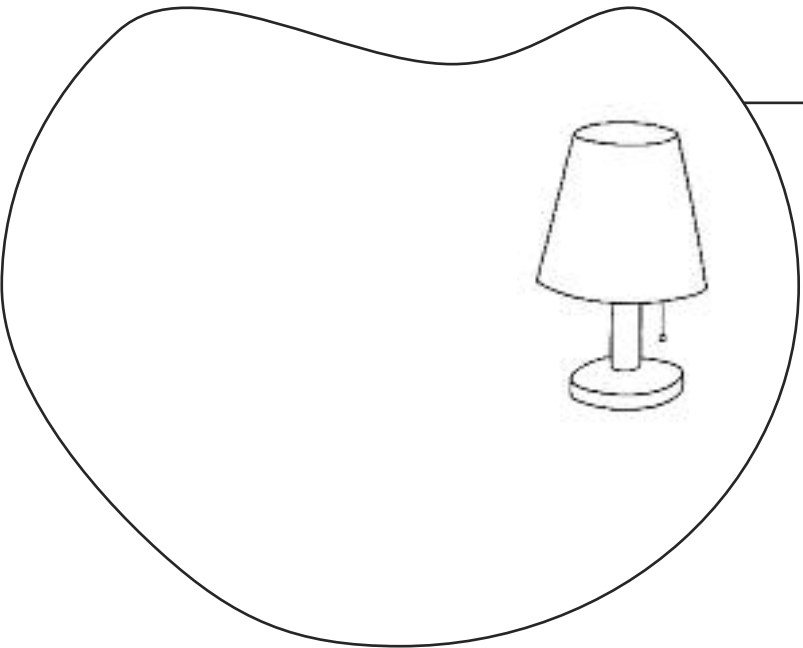
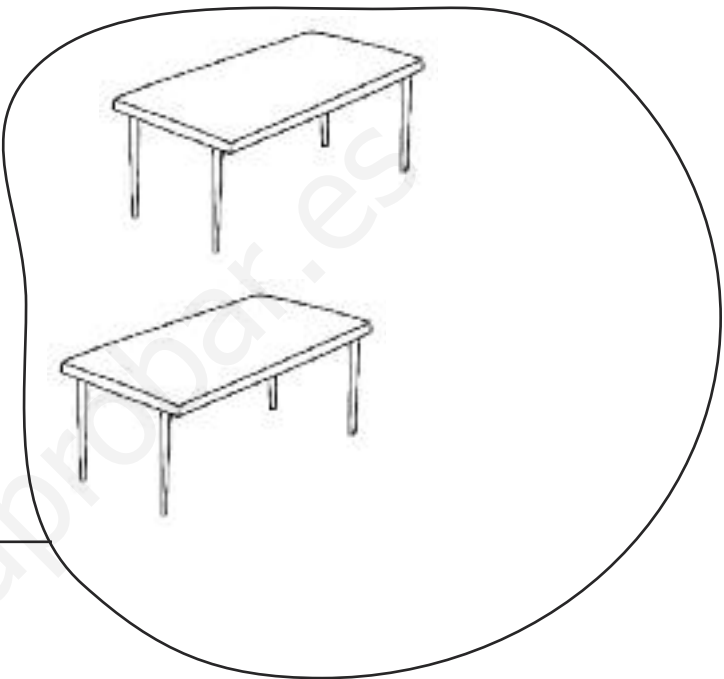

- Colorear de amarillo los espacios con el número 1, de azul los espacios con el número 2, de naranja los espacios con el número 3 y de verde, los del 4.

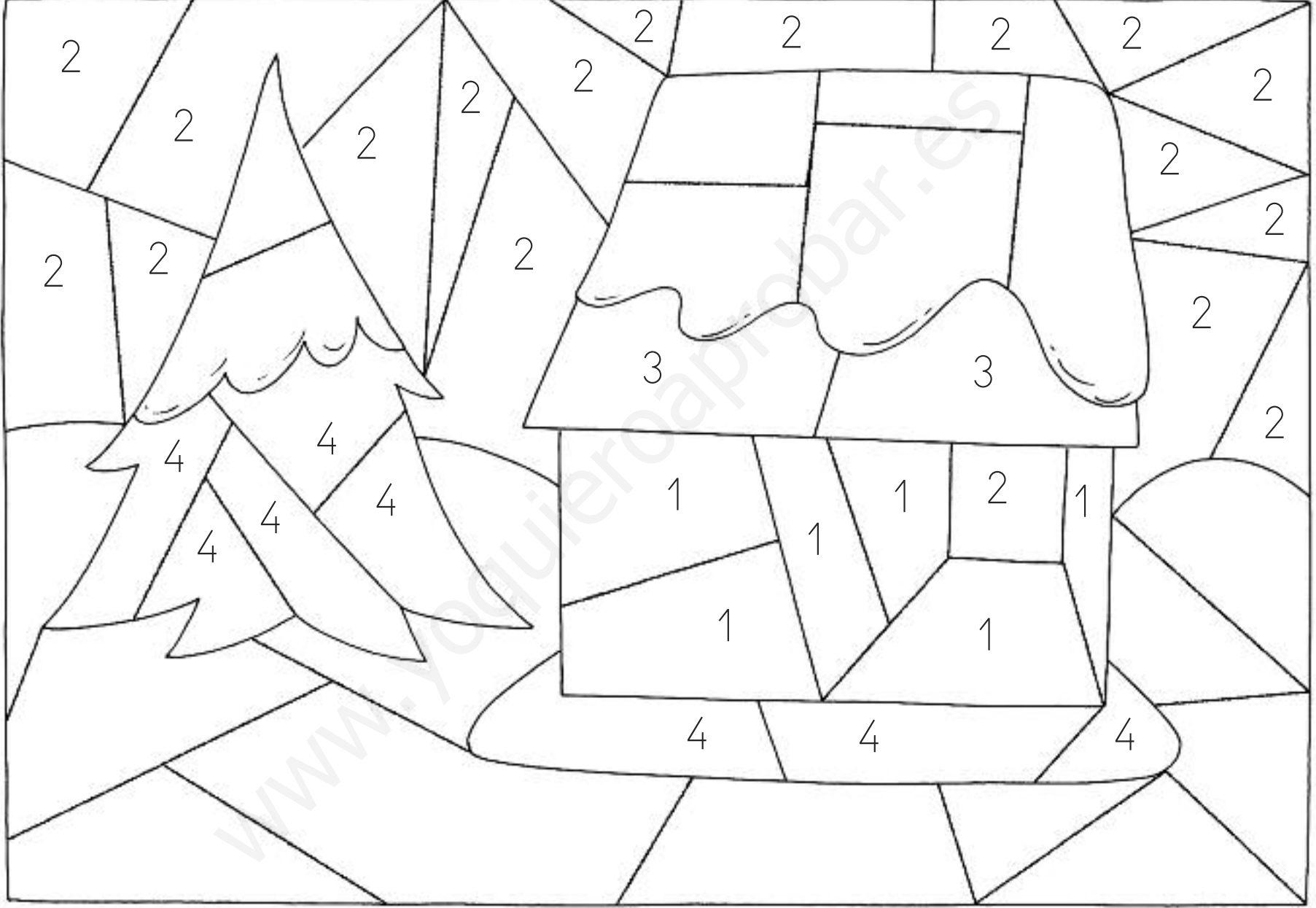

- Recortar los alimentos y pegarlos al lado del animal que los proporciona.
- Colorear el que más guste.

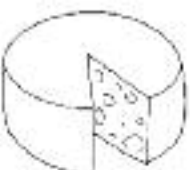
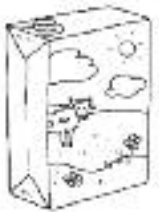
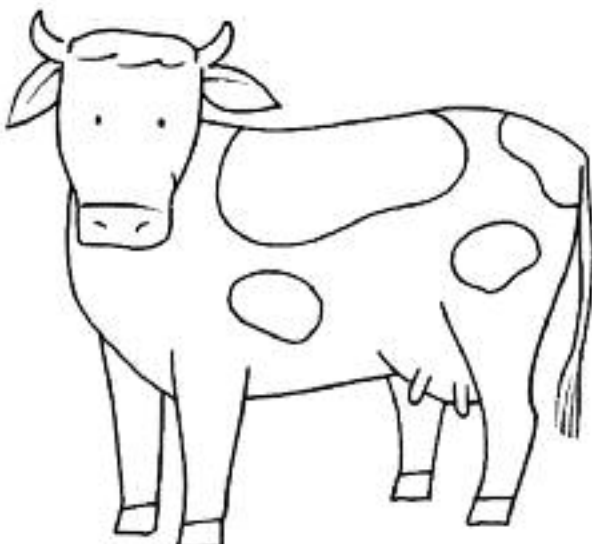
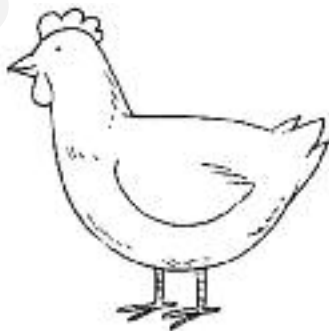
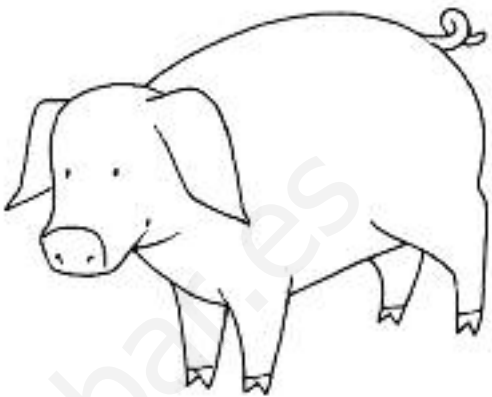

- Escribir los ordinales 1.º, 2.º y 3.º debajo de cada escena según ocurra por la mañana, por la tarde o por la noche.







- Colorear el perro que está cerca de la granja y dibujar un pájaro lejos de la granja.

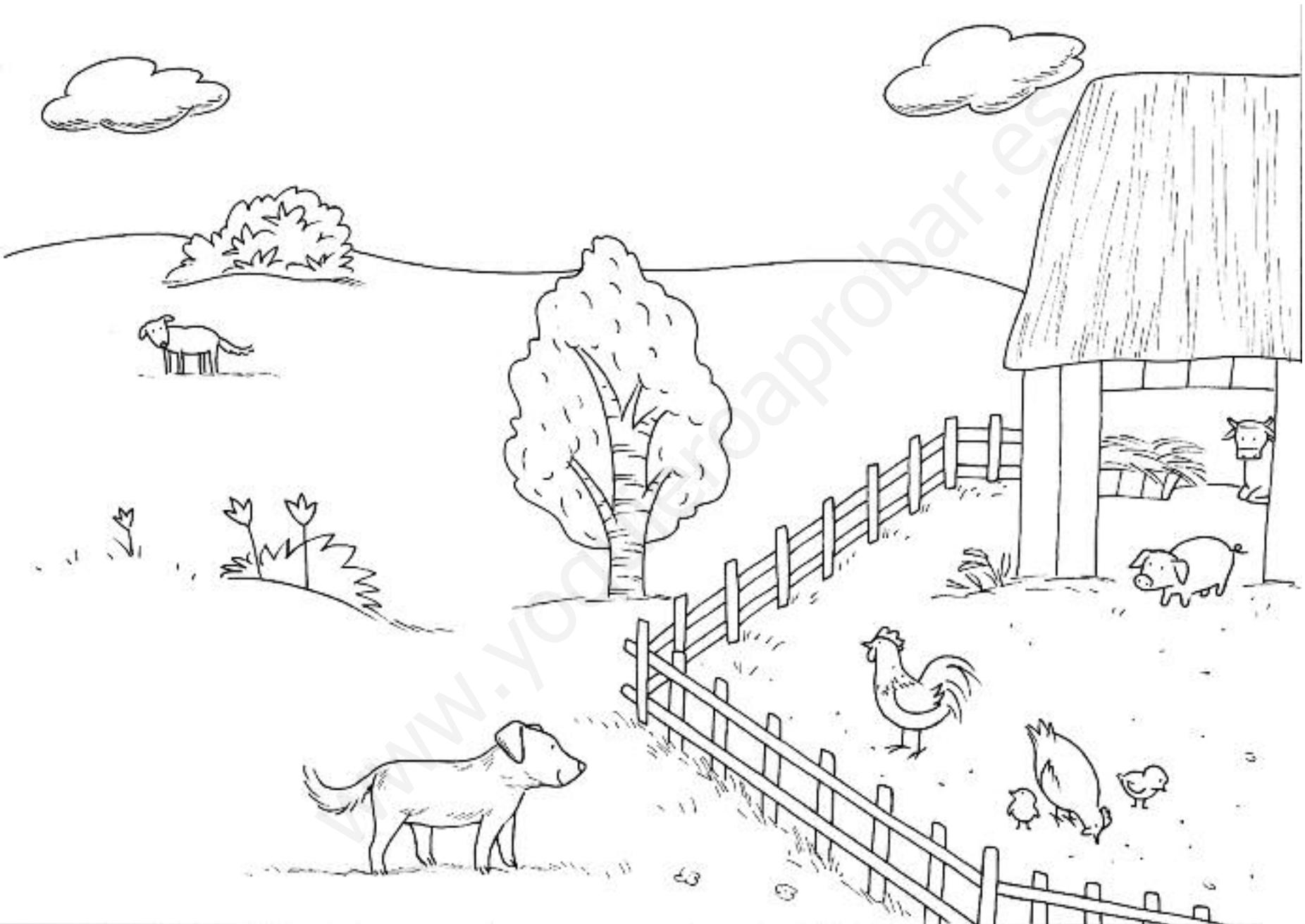



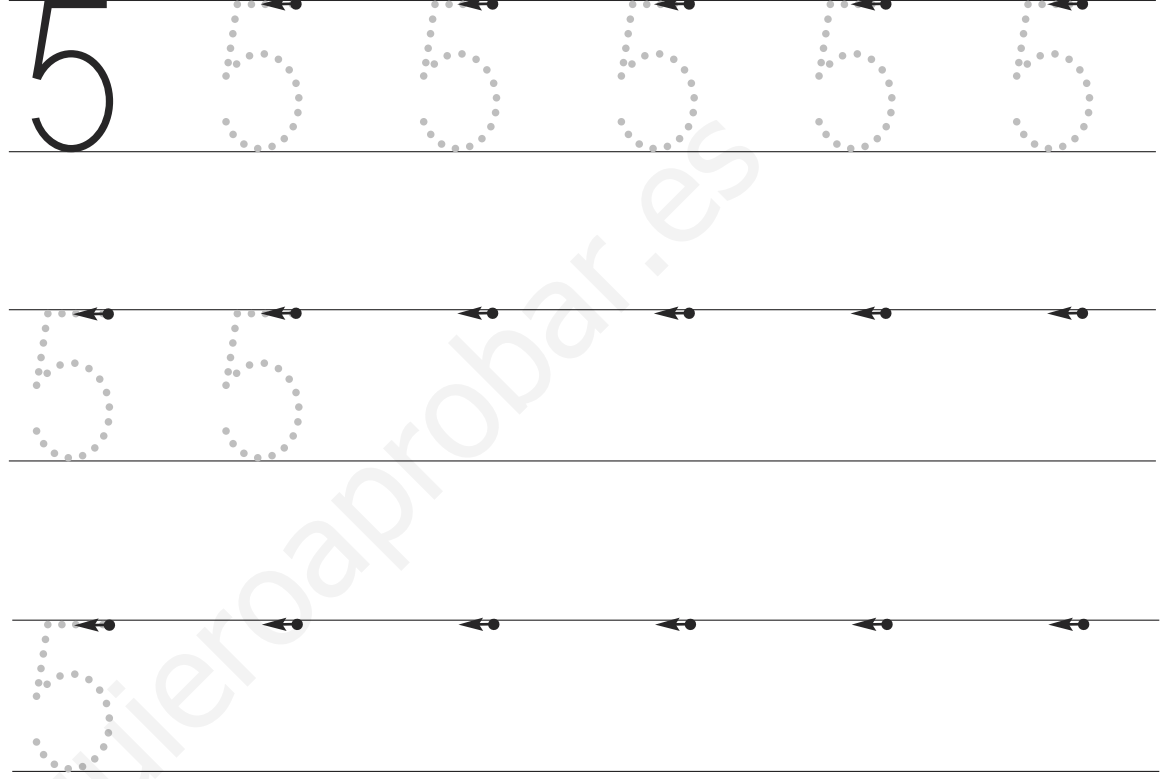
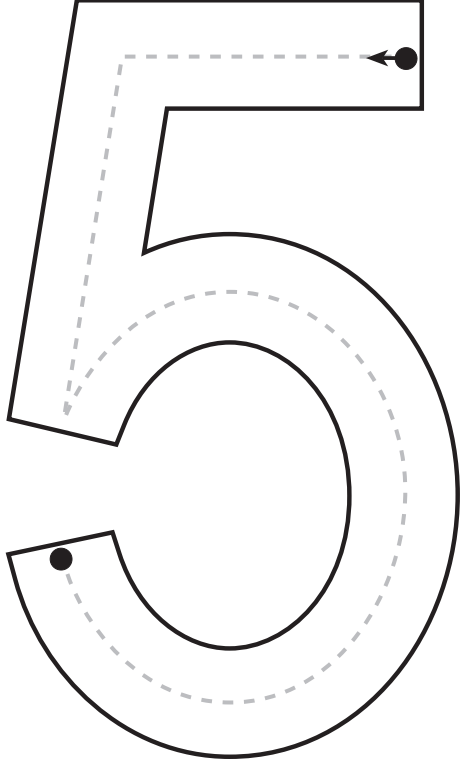
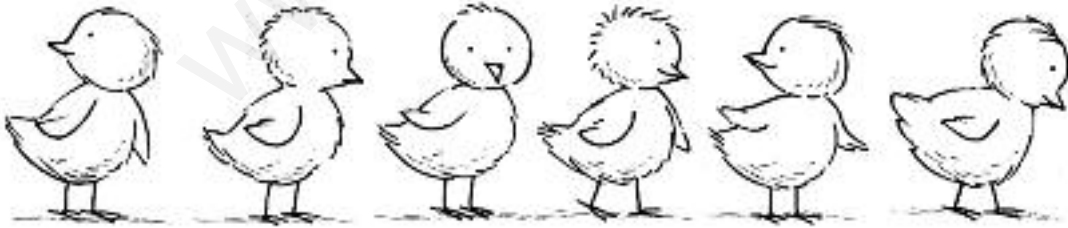

- Repasar y completar las grafías del 5.
- Colorear cinco pollitos.



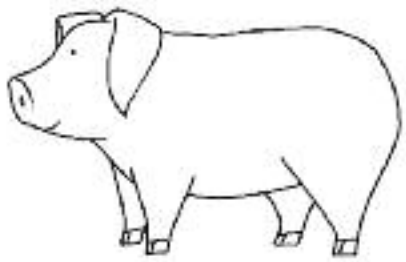
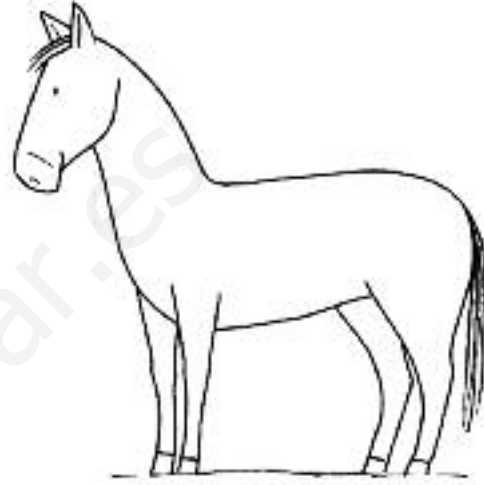

• Unir cada animal con la parte que le falta.



			
---	---	---	---

- Rodear cinco alimentos iguales y unirlos entre sí.
- Colorear los alimentos que suelen tomarse de postre.





- Dibujar tantos vasos como platos hay en la mesa.

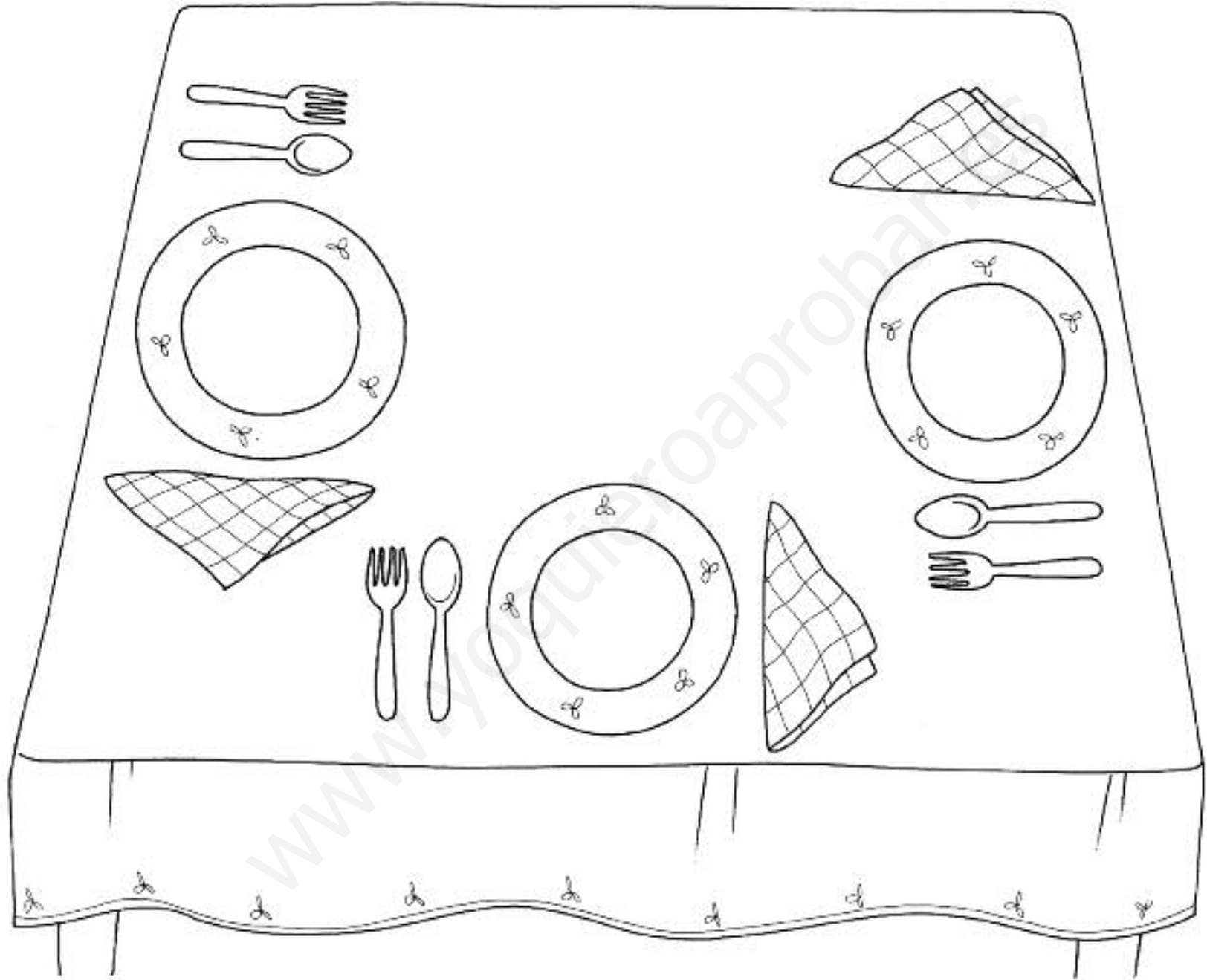

- Escribir el número que corresponde a cada conjunto.

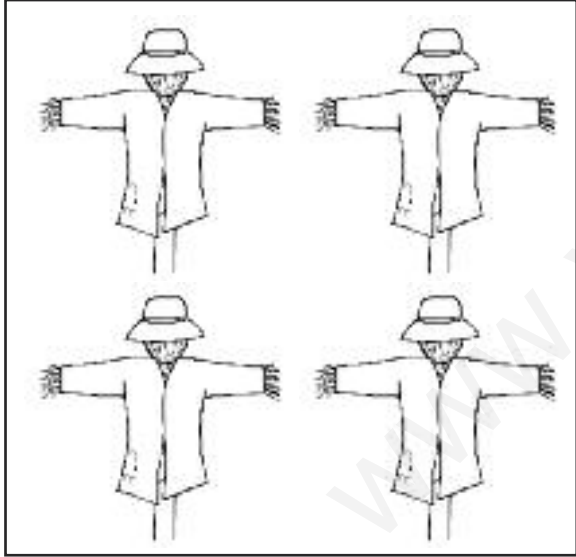

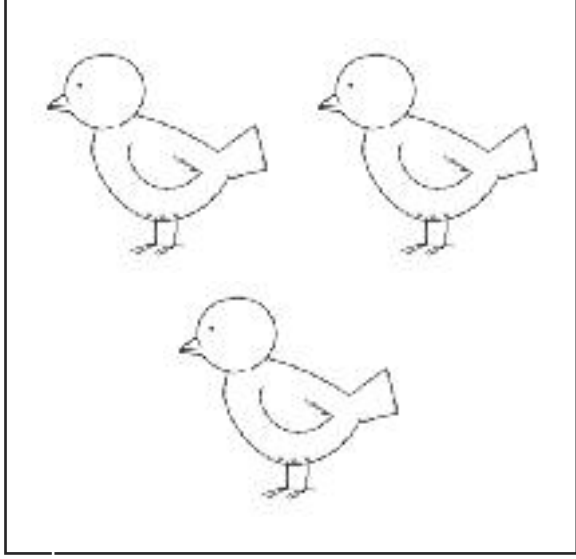

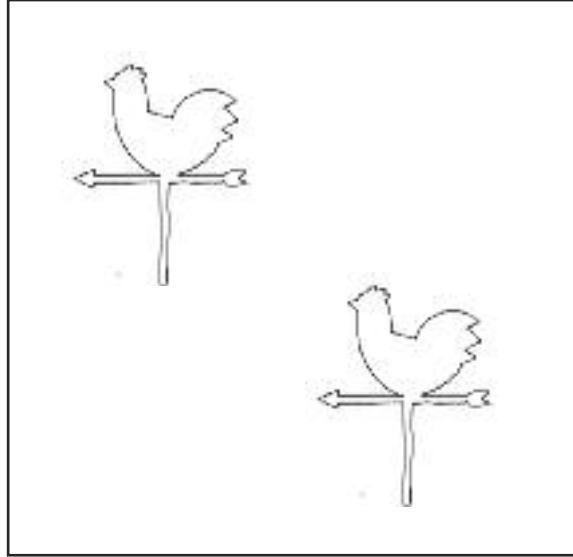

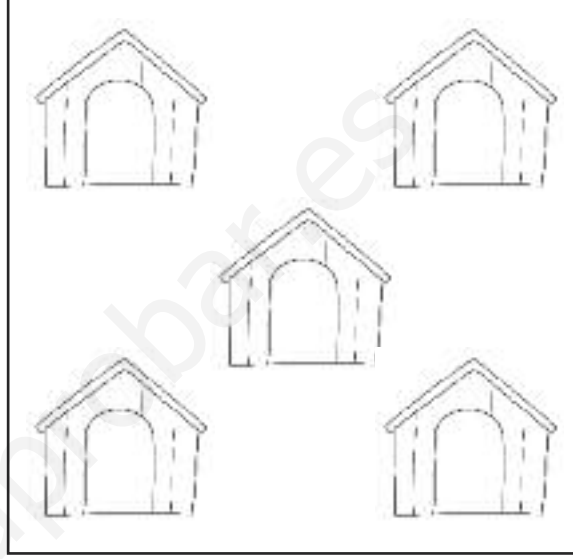



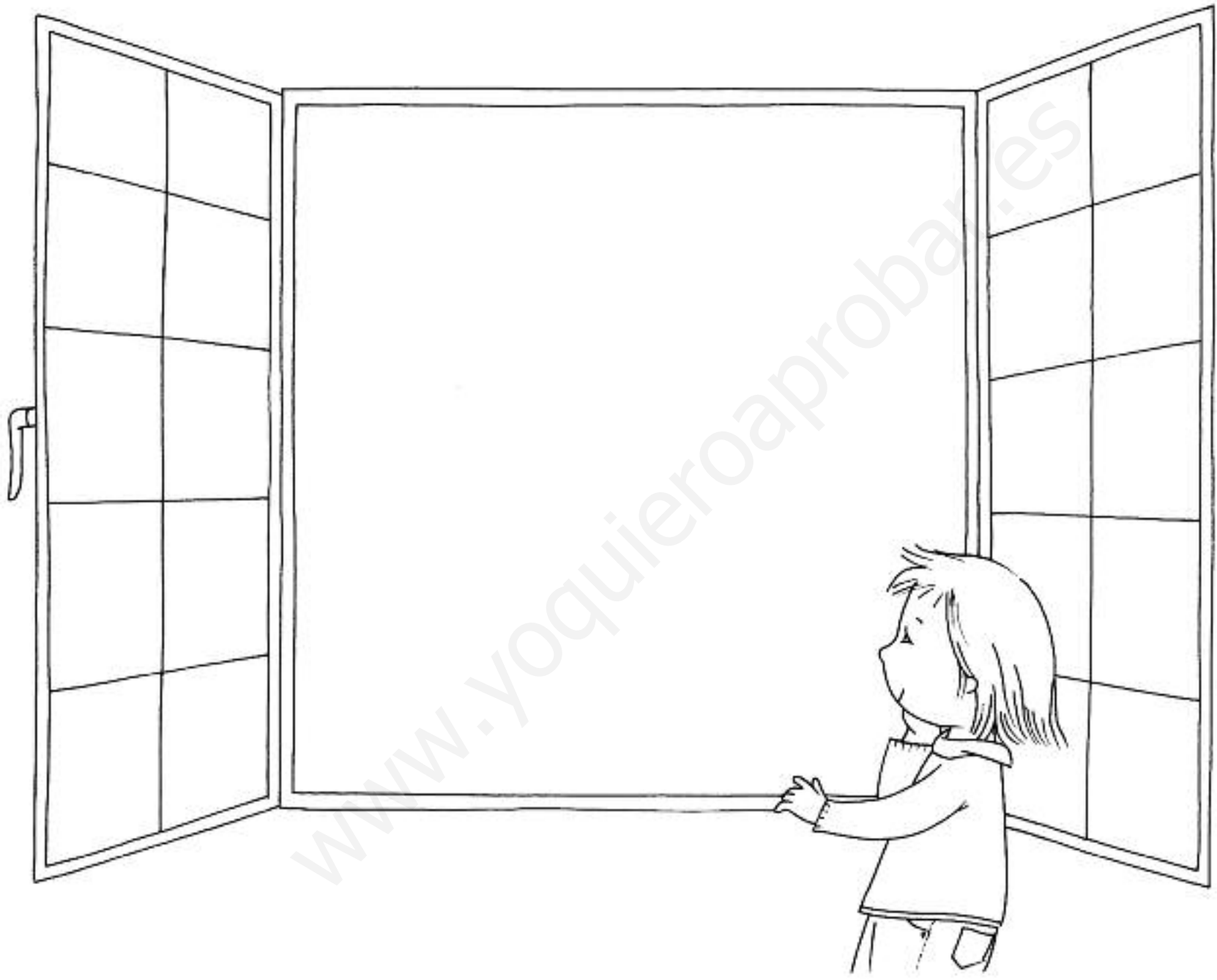

- Dibujar el paisaje que la niña está viendo por la ventana.



- Dibujar la estrella de Lila cuando está de frente.
- Escribir en cada casilla el número de veces que Lila está de frente y de espaldas.

	
---	--

	
--	--

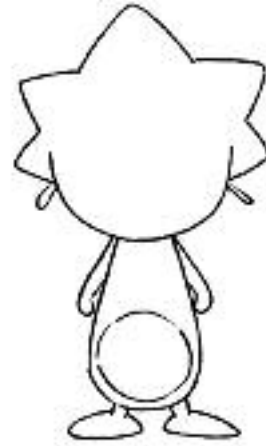
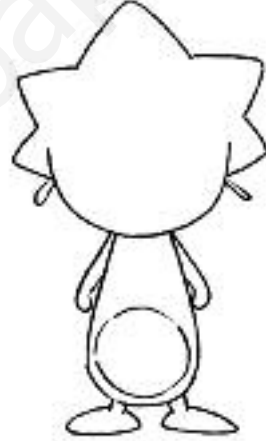
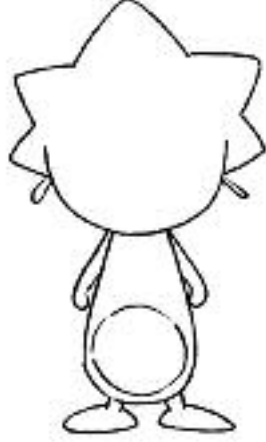
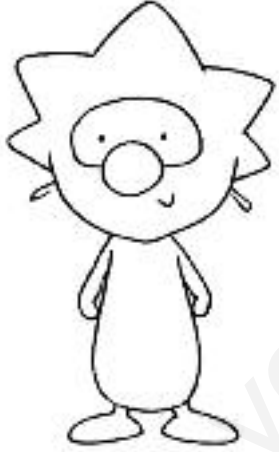
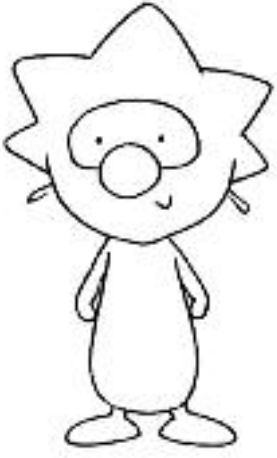

- Colorear las abejas que están alrededor de la colmena.
- Dibujar las abejas necesarias para que haya más en la flor que en el panal.

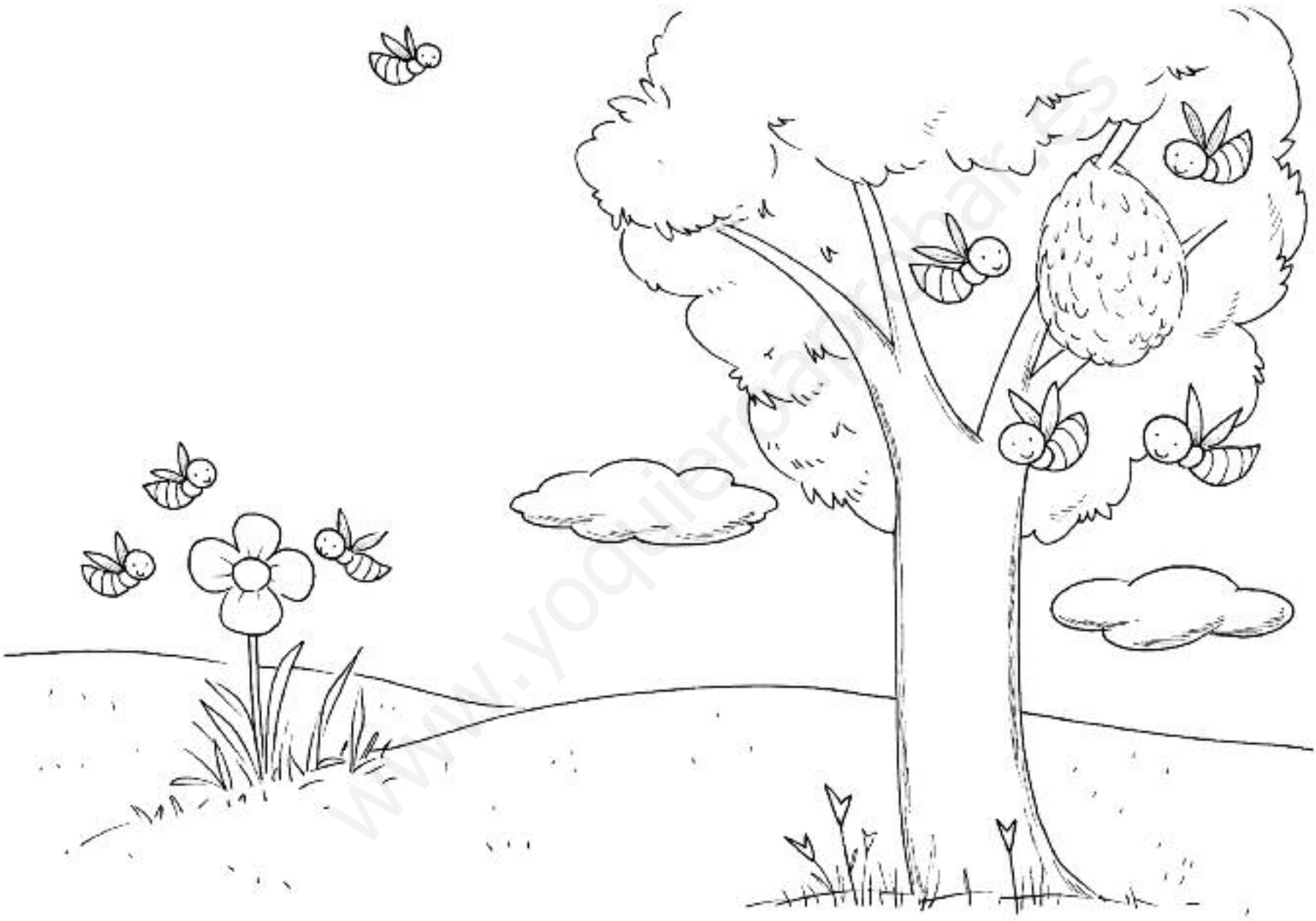

- Recortar los objetos y pegarlos donde corresponden según sean pesados o ligeros.

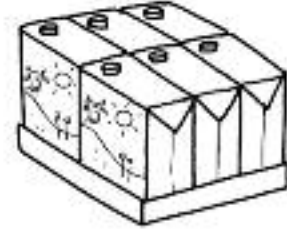
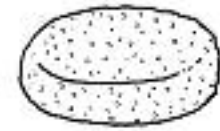
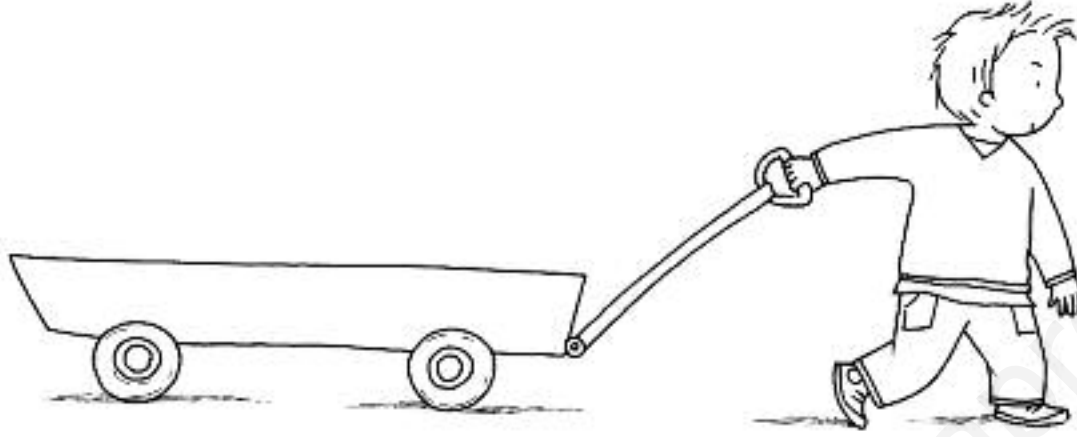
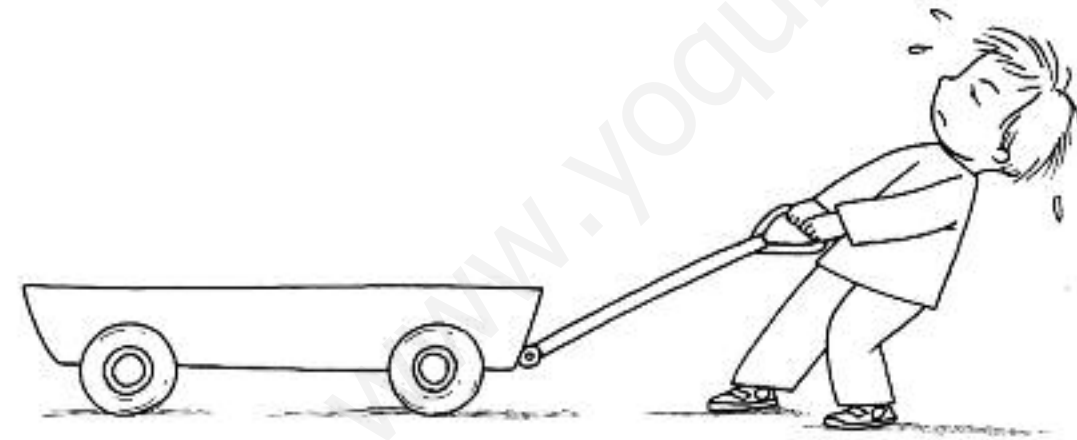

- Colorear de verde los tejados de las casas que tienen más ventanas que el modelo y de naranja los de las casas que tienen menos ventanas que el modelo.



- Dibujar los elementos que resultan al juntar los dos grupos y escribir el resultado.

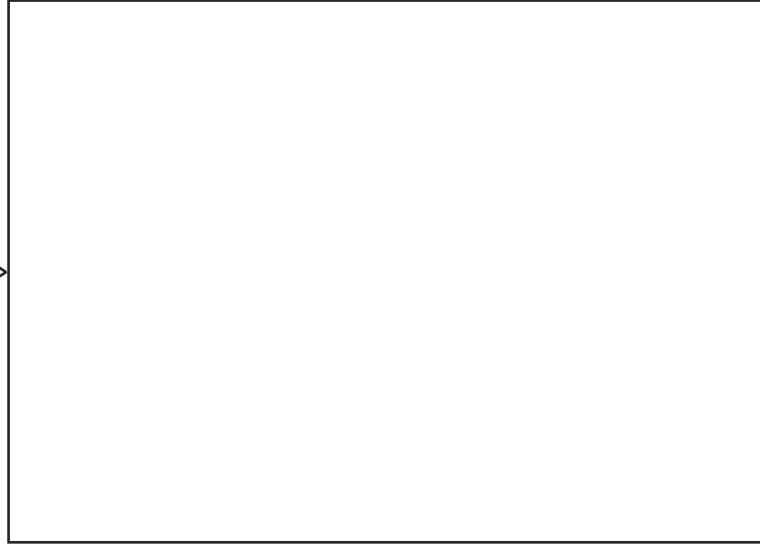
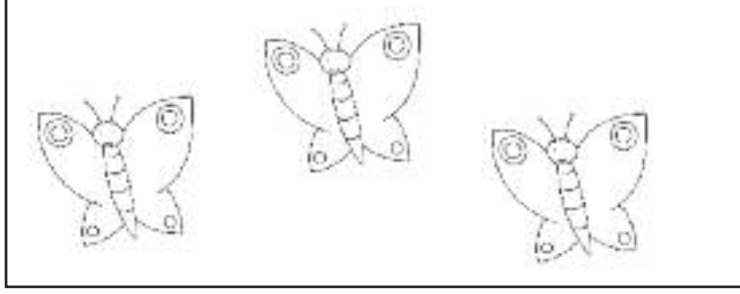
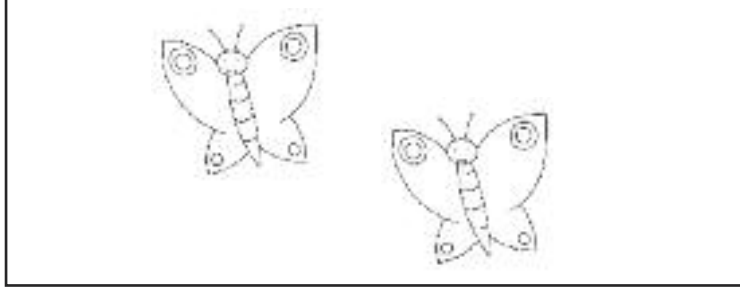
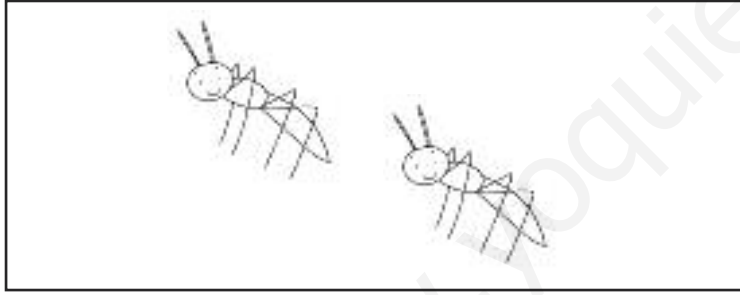
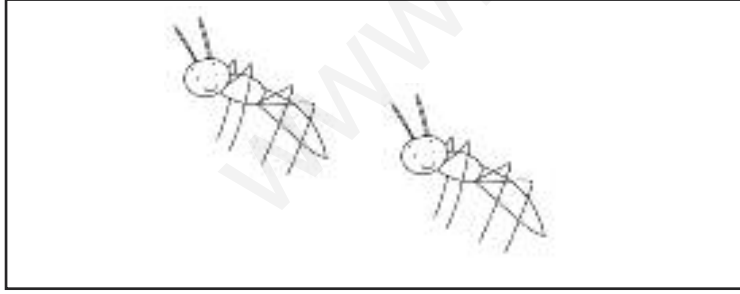

- Trazar un camino para que el topo llegue a la galería y colorearlo.

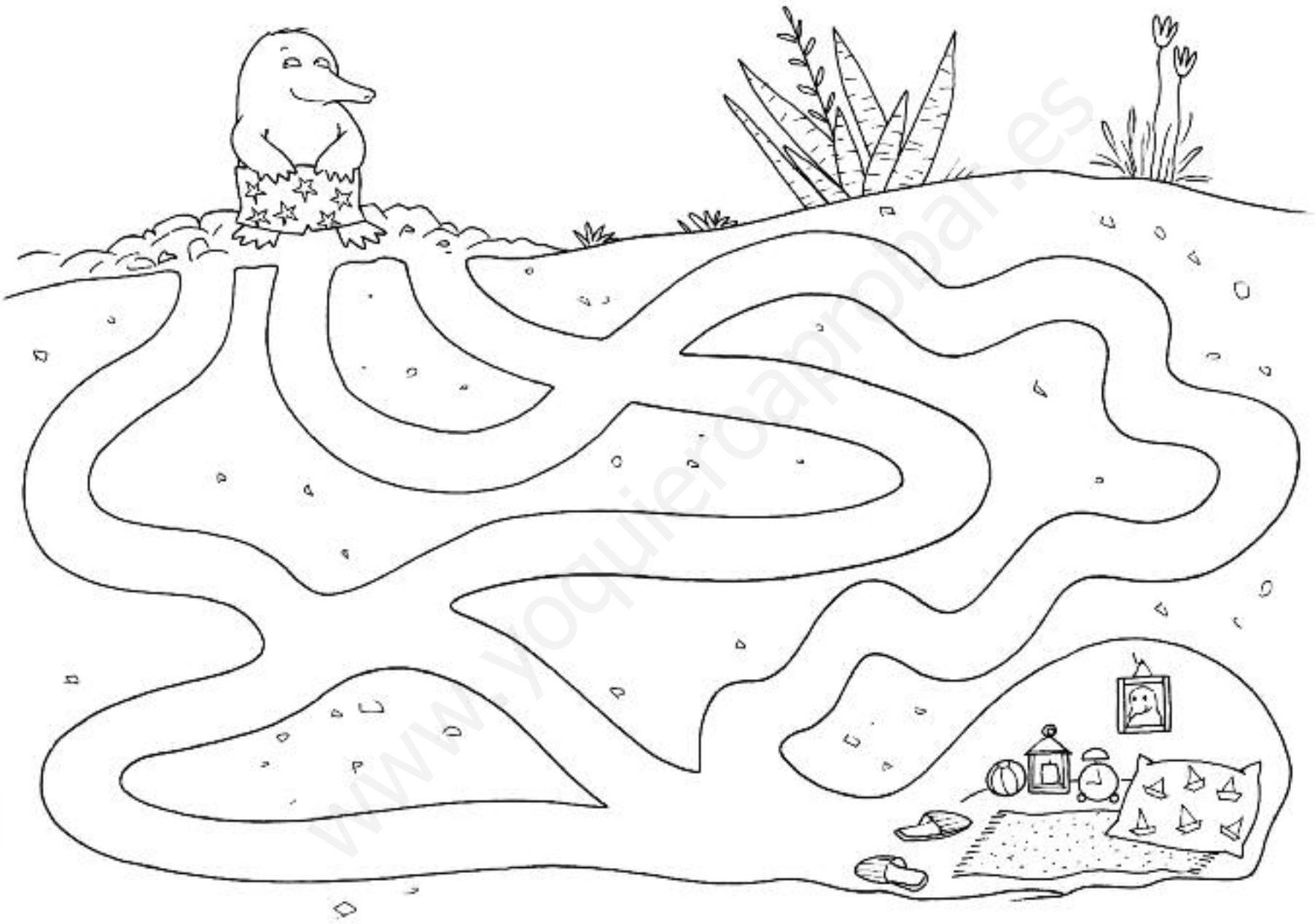

- Buscar los cinco errores de la escena de primavera.

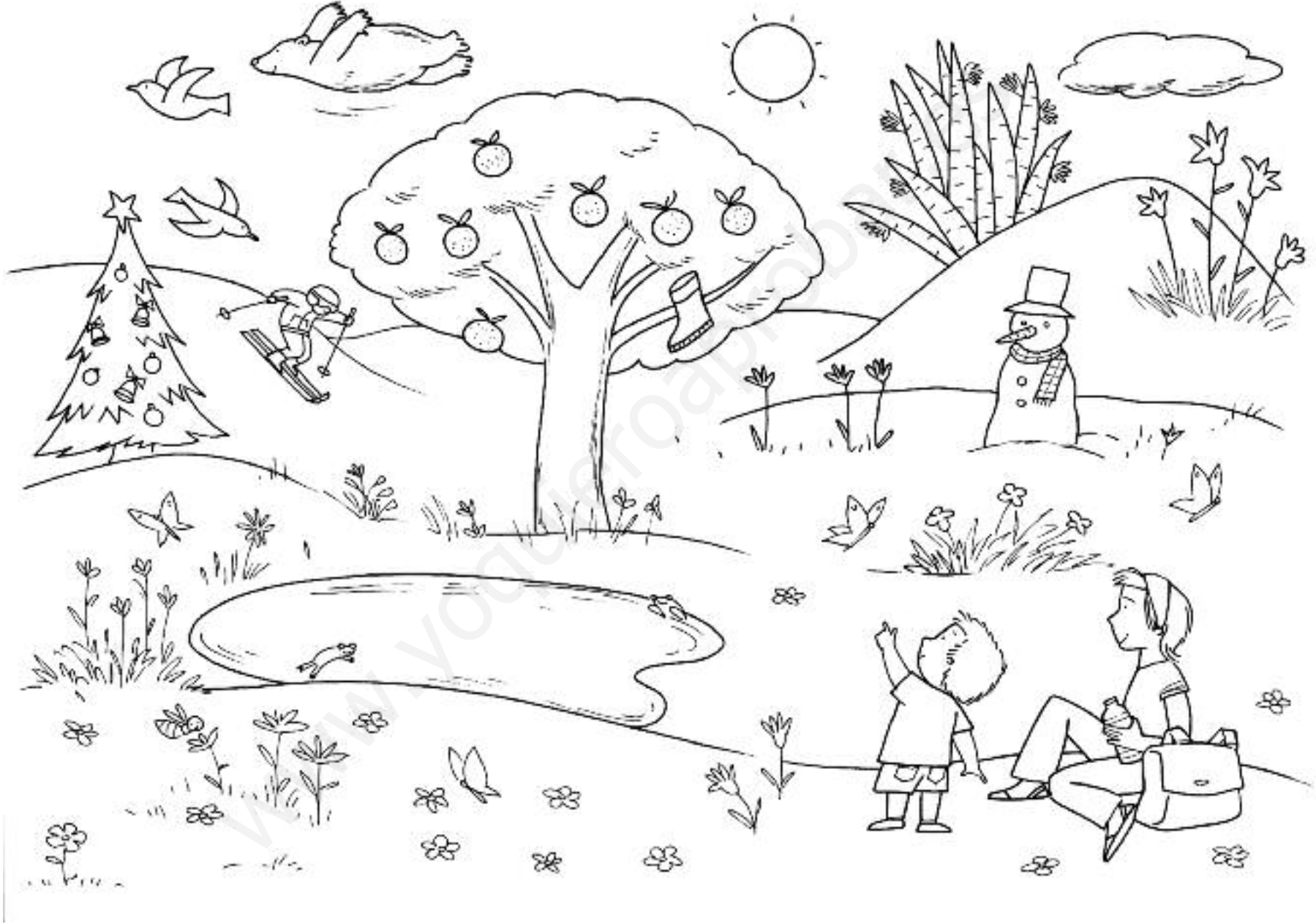

- Dibujar algún animal marino entre la roca y las algas.

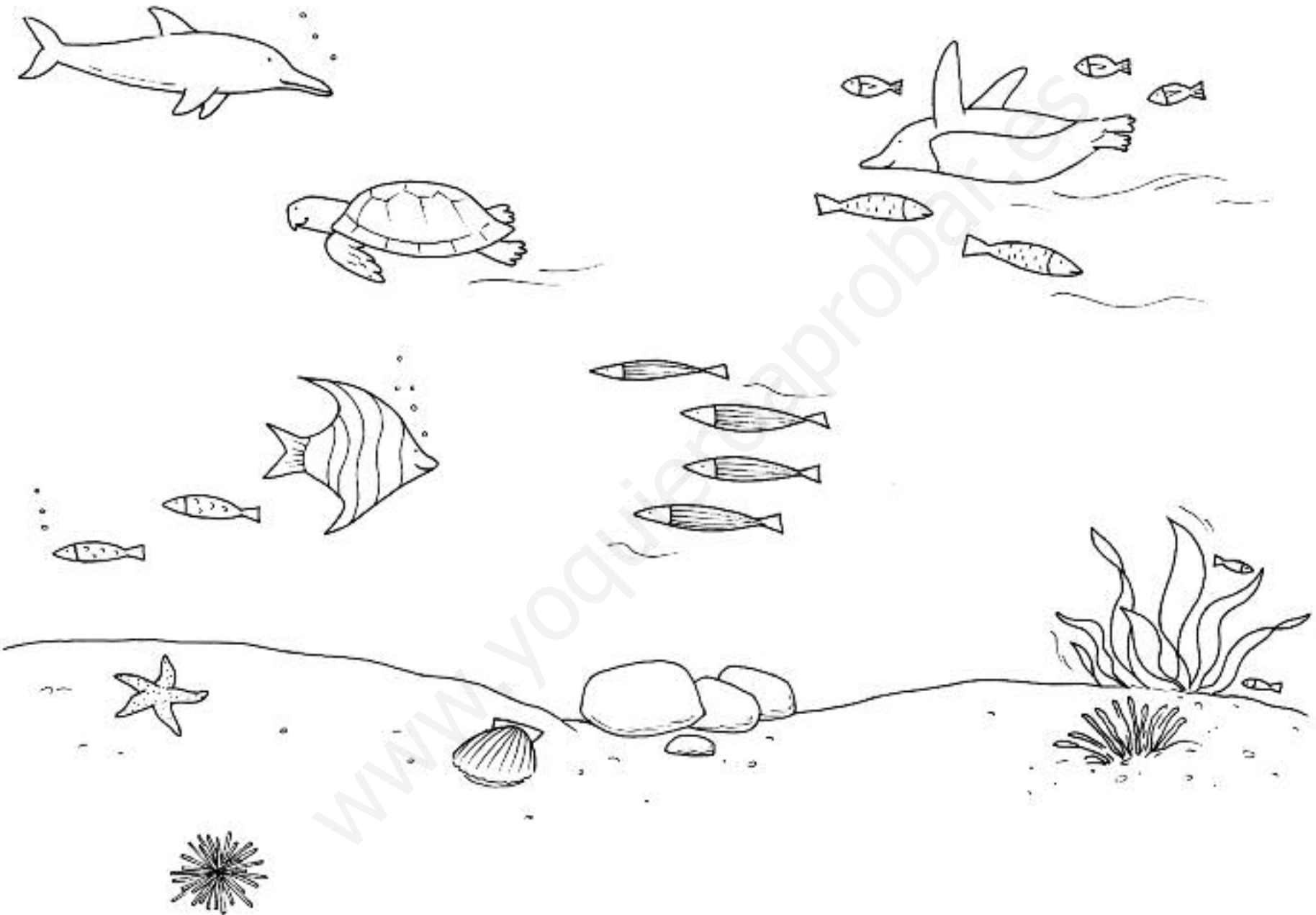

- Realizar las series.

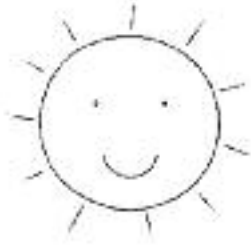
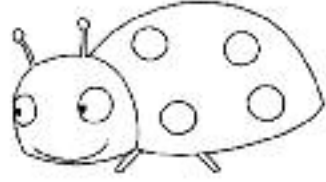
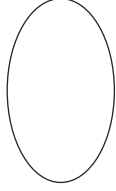
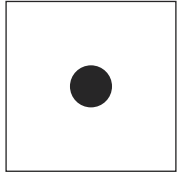

- Escribir los números que corresponden para completar y resolver las sumas.

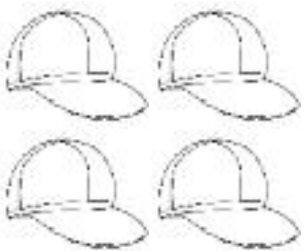

+



=



+



=

- Unir cada animal con el medio por el que se desplaza.
- Colorear al animal más lento.

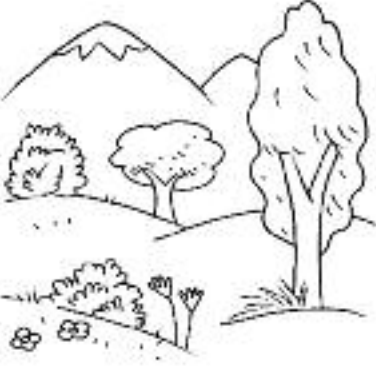
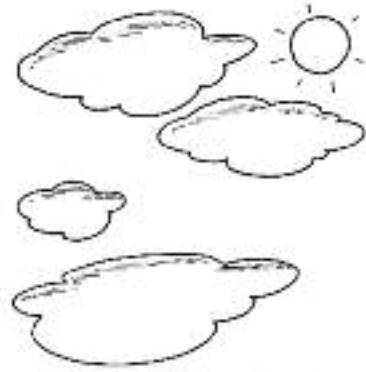
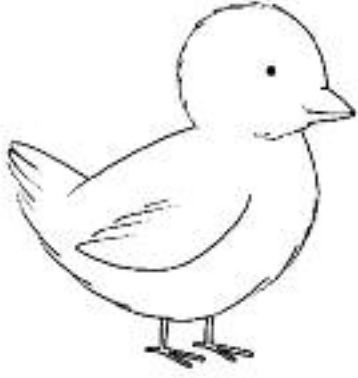
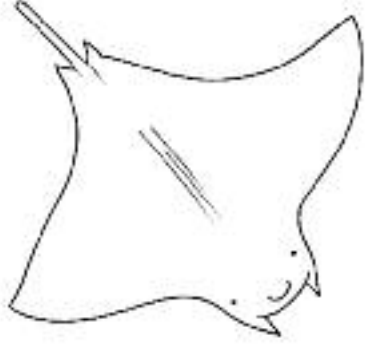



- Repasar las grafías del 6.
- Colorear seis hojas de la planta.

Tracing practice for the number 6. The page contains six rows of handwriting lines. The first row shows a solid number 6 followed by five dotted number 6s, each with a starting dot and an arrow indicating the direction of the stroke. The second row shows two dotted number 6s followed by four horizontal lines with starting dots and arrows. The third row shows one dotted number 6 followed by five horizontal lines with starting dots and arrows. The fourth row shows one dotted number 6 followed by five horizontal lines with starting dots and arrows. The fifth row shows one dotted number 6 followed by five horizontal lines with starting dots and arrows. The sixth row shows one dotted number 6 followed by five horizontal lines with starting dots and arrows.

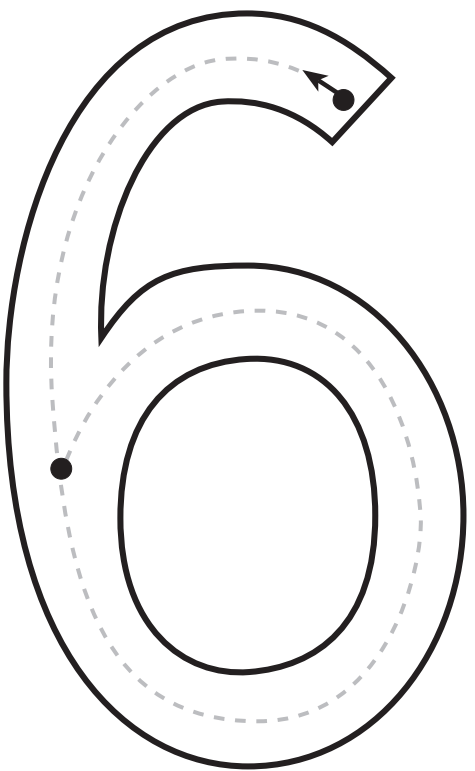

- Dibujar las manchas necesarias para que todas las vacas tengan seis.

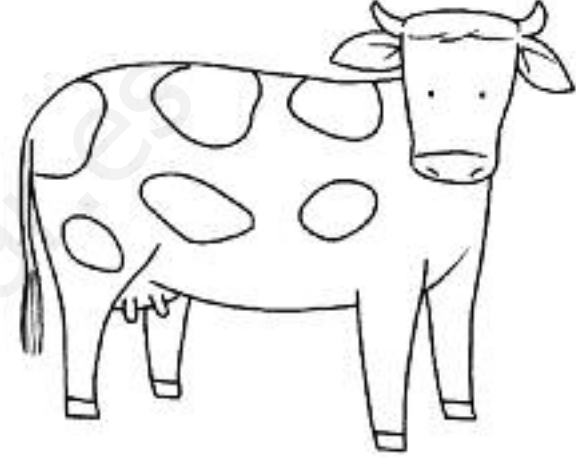
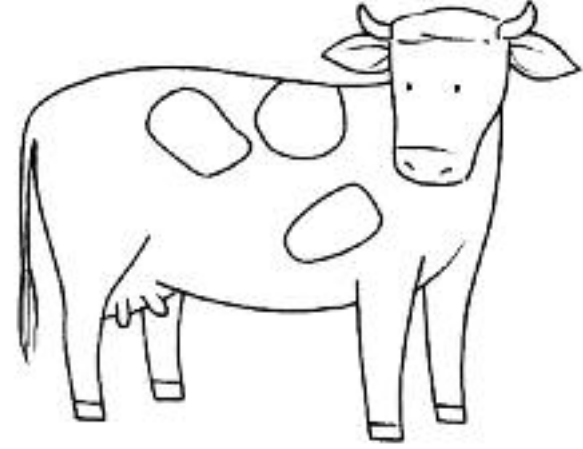
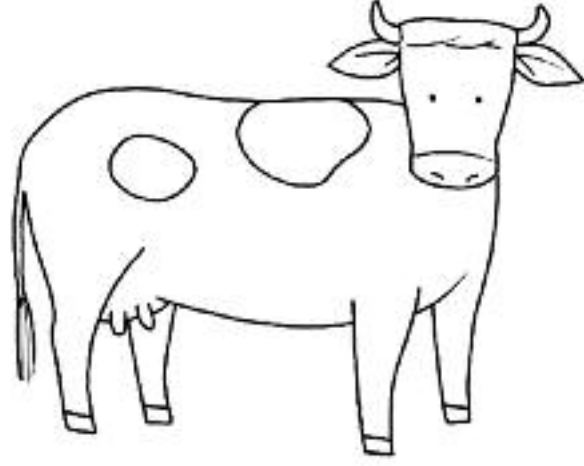
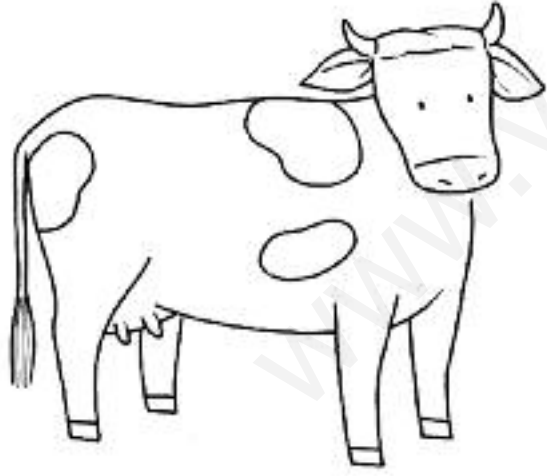



- Encontrar el animal marino escondido y colorearlo.

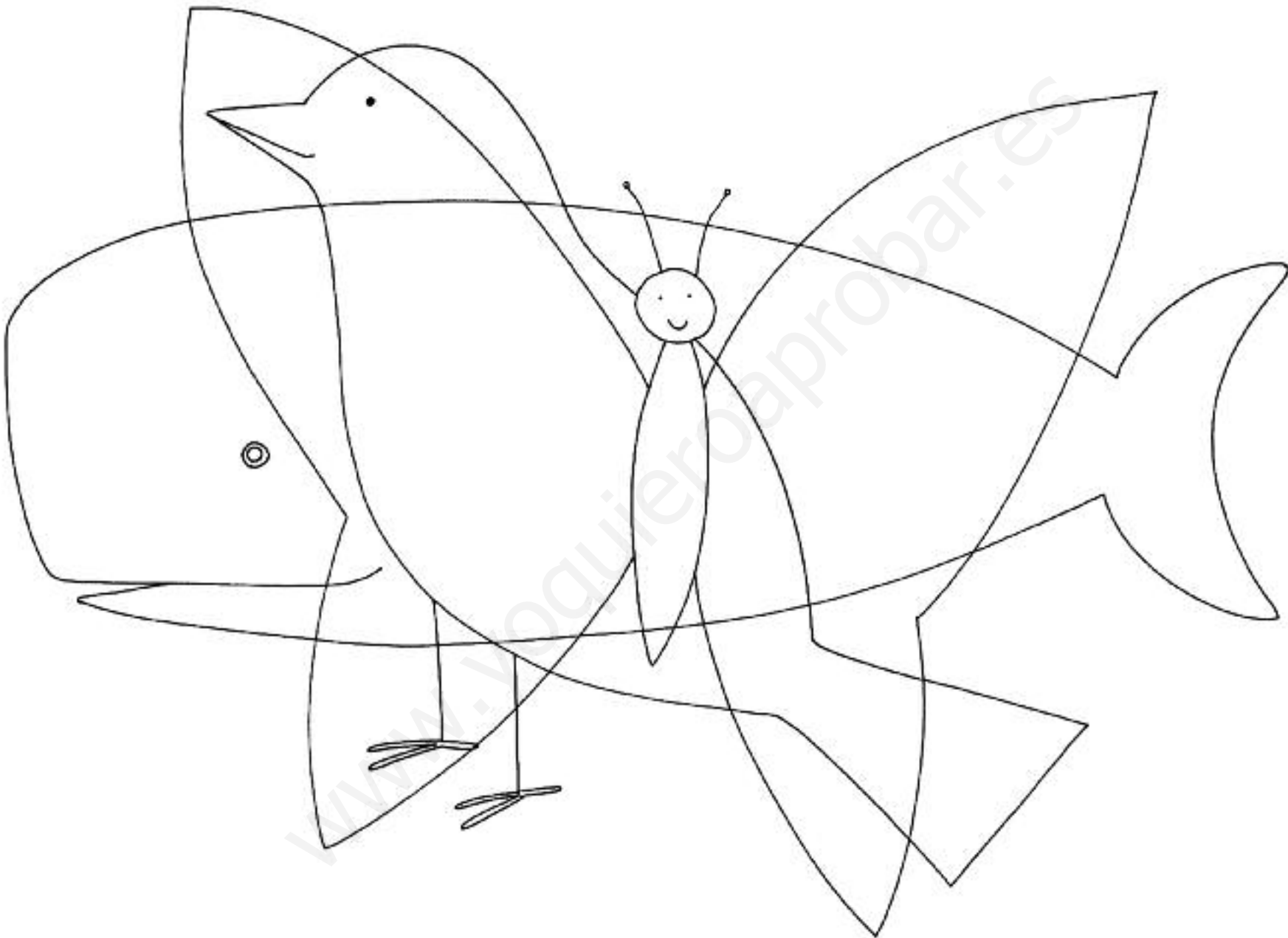

- Colorear al animal que es más alto que el árbol.

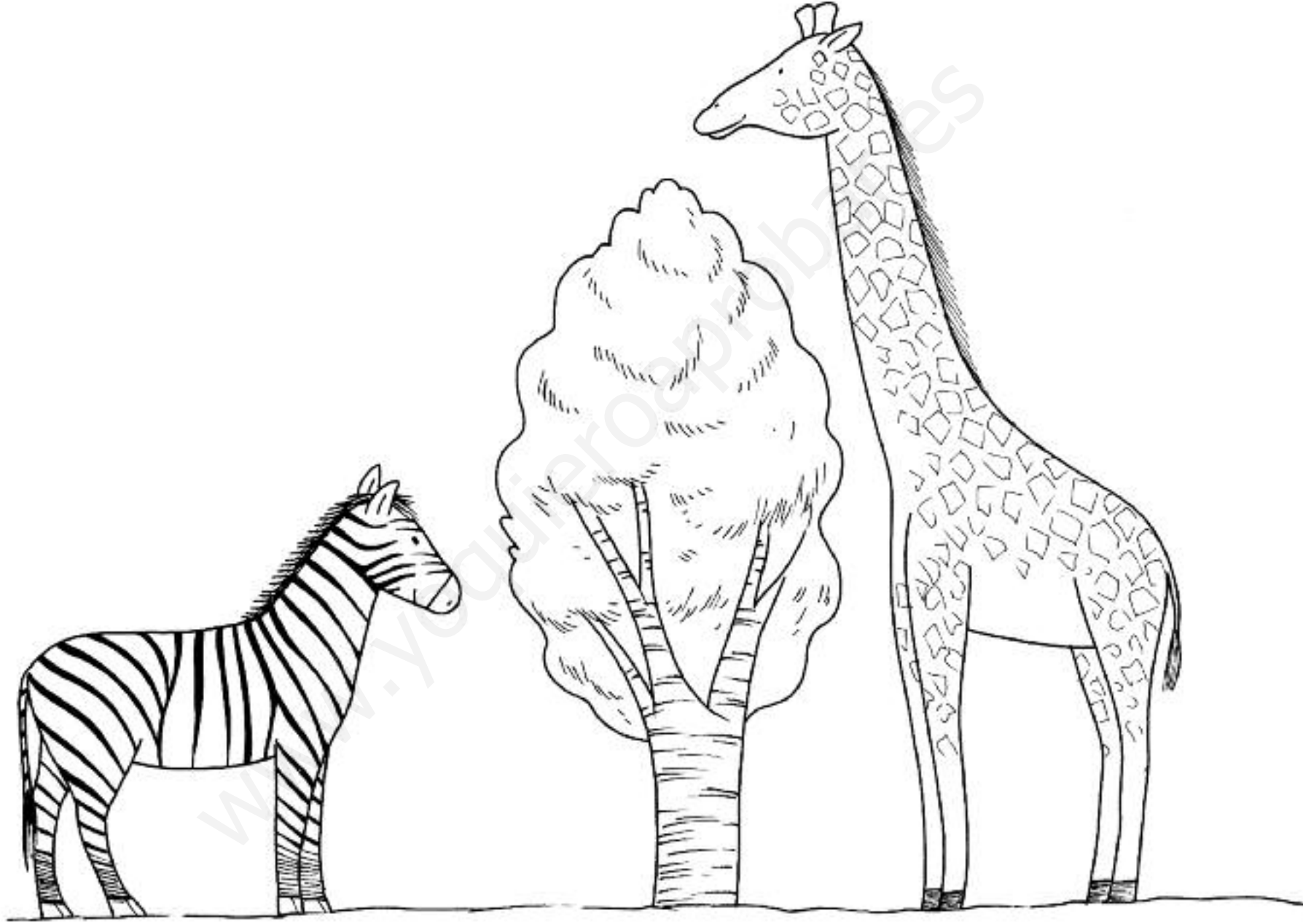



UNIDAD 9

- Unir los números por orden para descubrir el dibujo escondido.
- Dibujar seis nubes en el cielo

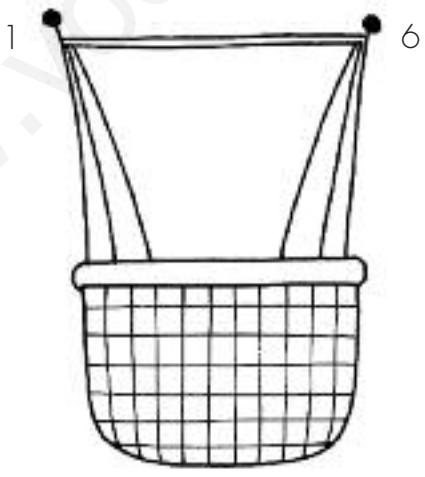
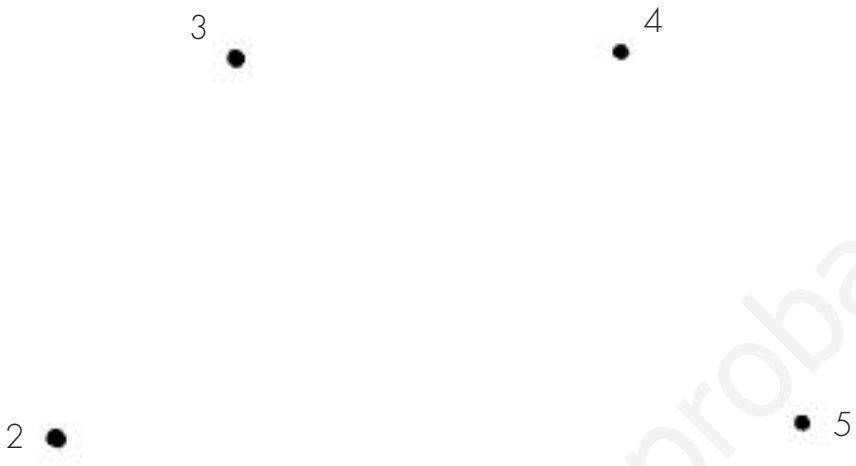

- Tachar los vehículos que tienen ruedas. Tachar los vehículos que no se desplazan por el aire. Colorear los que quedan.

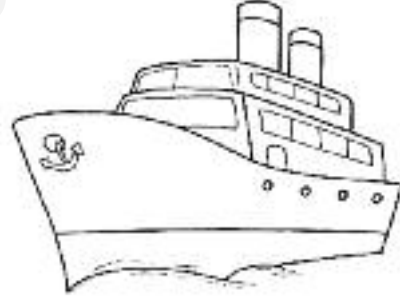
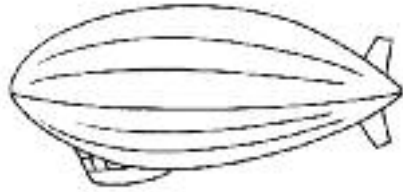
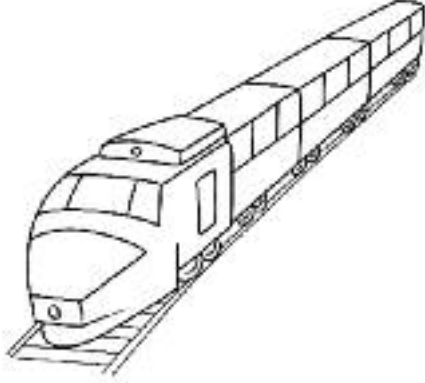
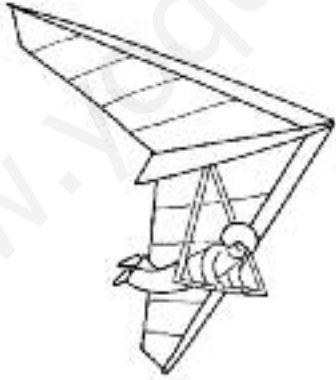
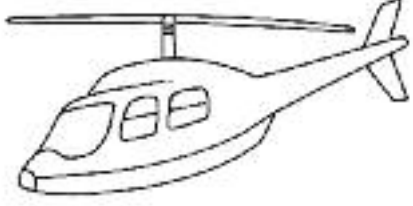
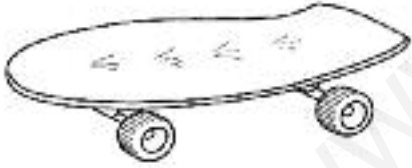



- Escribir los números que corresponden para completar y resolver las sumas.



+

=

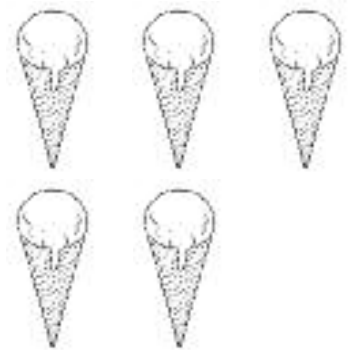

+

=

www.yoquieroaprobar.es

- Contar el número de toallas, barcos, gaviotas y sombrillas que aparecen en la escena y escribirlo en la casilla correspondiente.

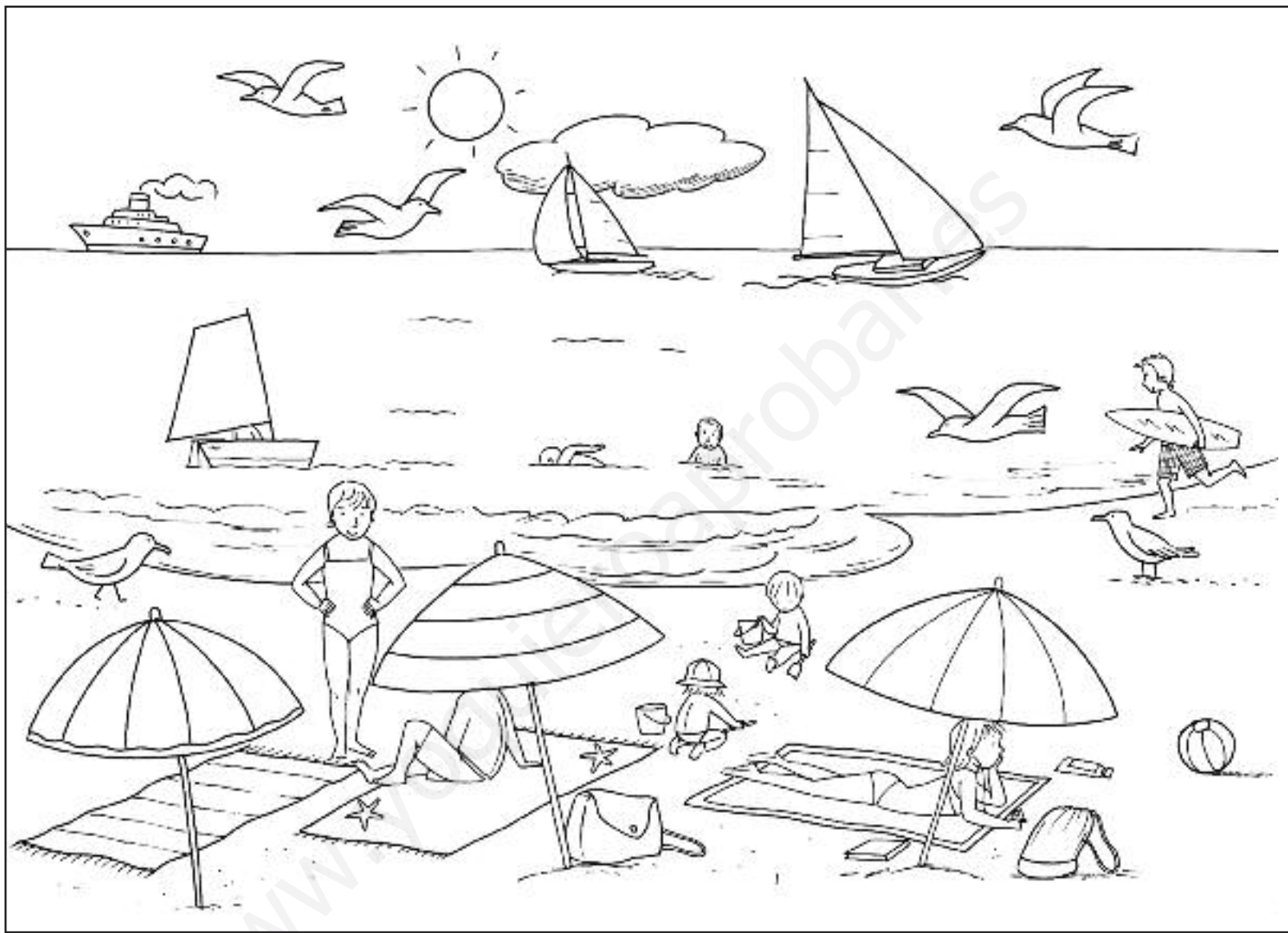









UNIDAD 9

- Observar los dibujos tratando de memorizarlos. Doblar la hoja por la mitad y dibujarlos.

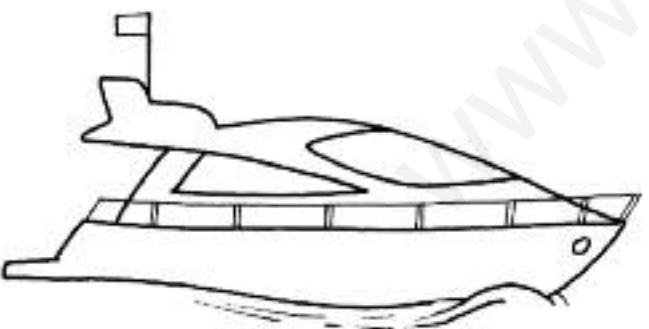
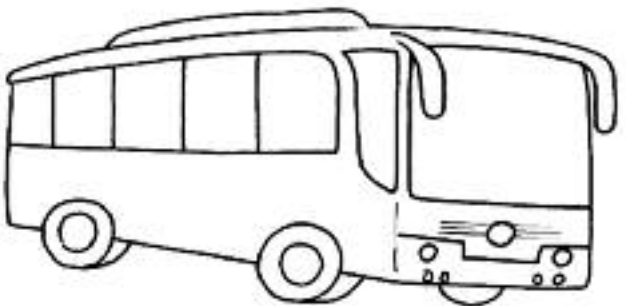
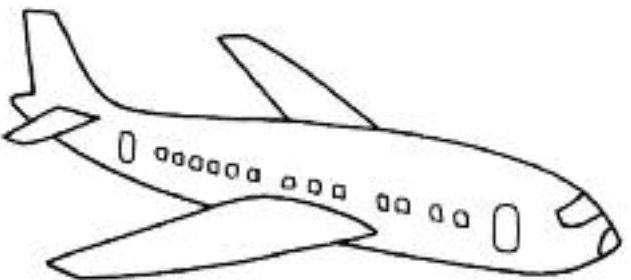



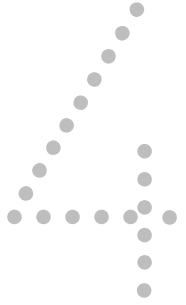
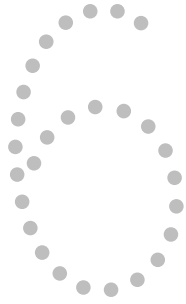

- Repasar los números y rodear en cada fila tantos elementos como indican.

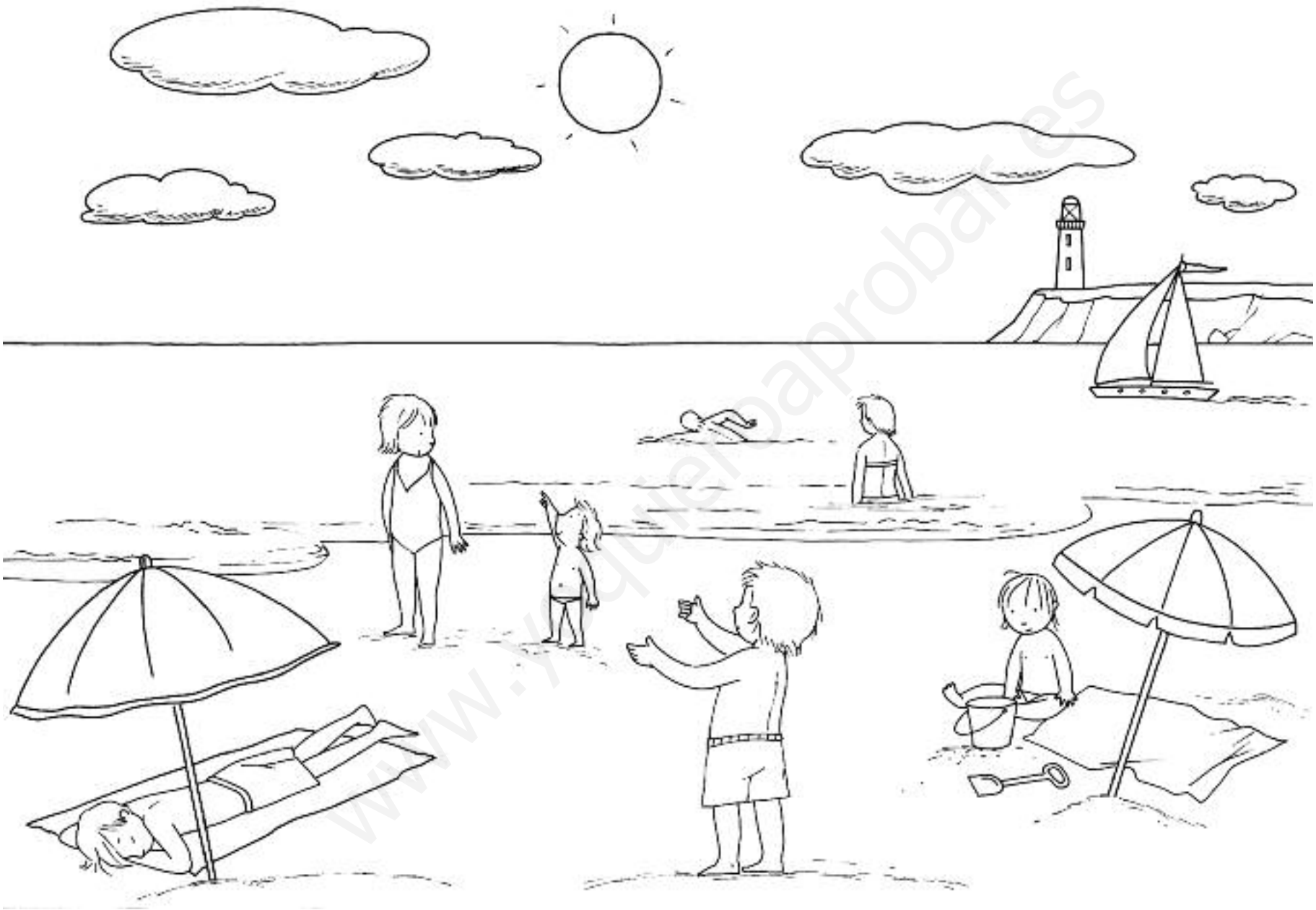

- Dibujar un helado en la mano derecha del niño.
- Colorear la sombrilla que está a la izquierda del niño.



- Escribir los números o dibujar los elementos para completar y resolver las sumas.

<p>3</p> 	+	<p>2</p> 	=	_____
<p>_____</p> 	+	<p>2</p>	=	_____
<p>1</p>	+	<p>_____</p> 	=	_____



- Unir cada figura con su silueta.

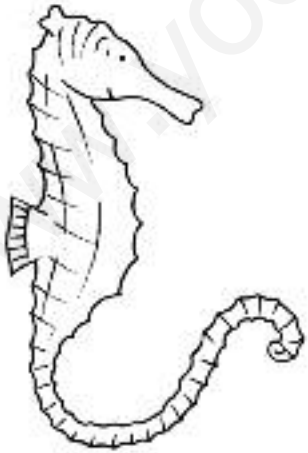
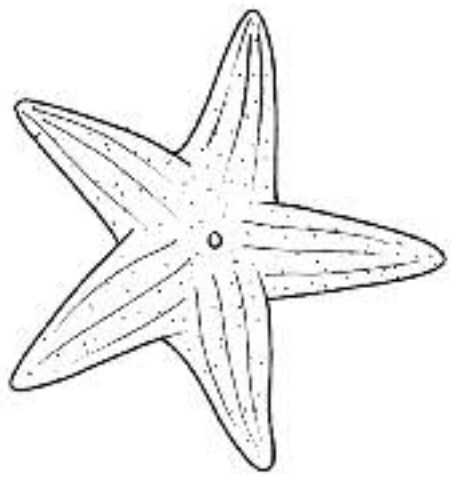
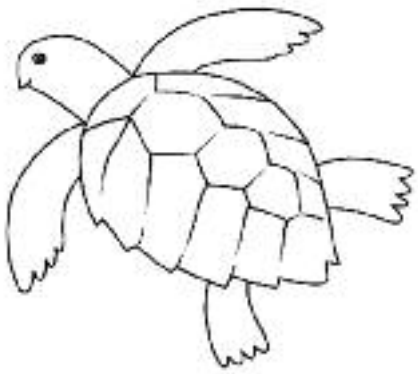
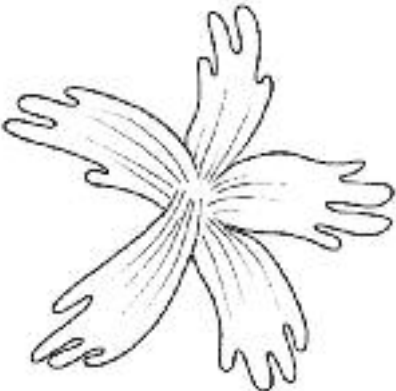



- Repasar y completar las grafías del 7.
- Buscar los números 7 escondidos y colorearlos.

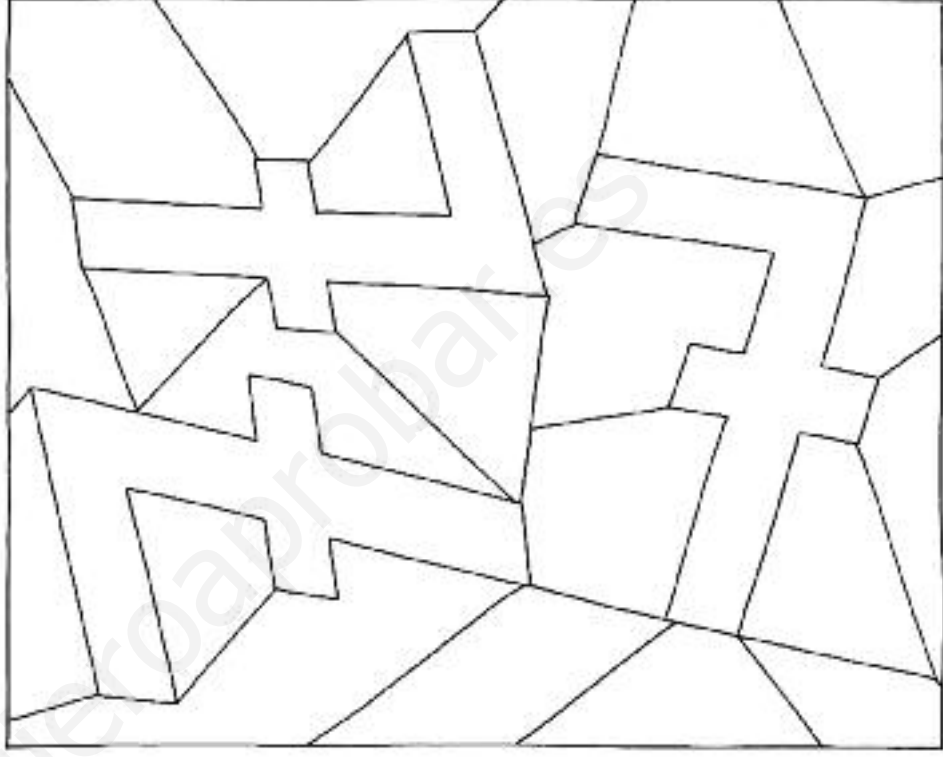
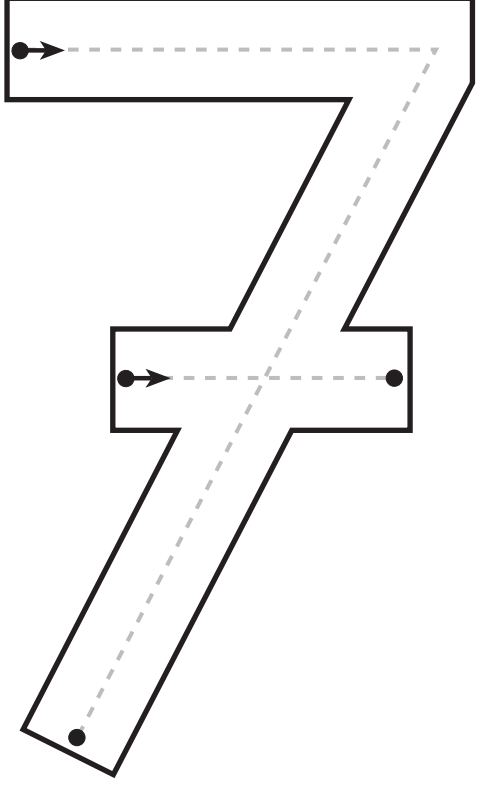
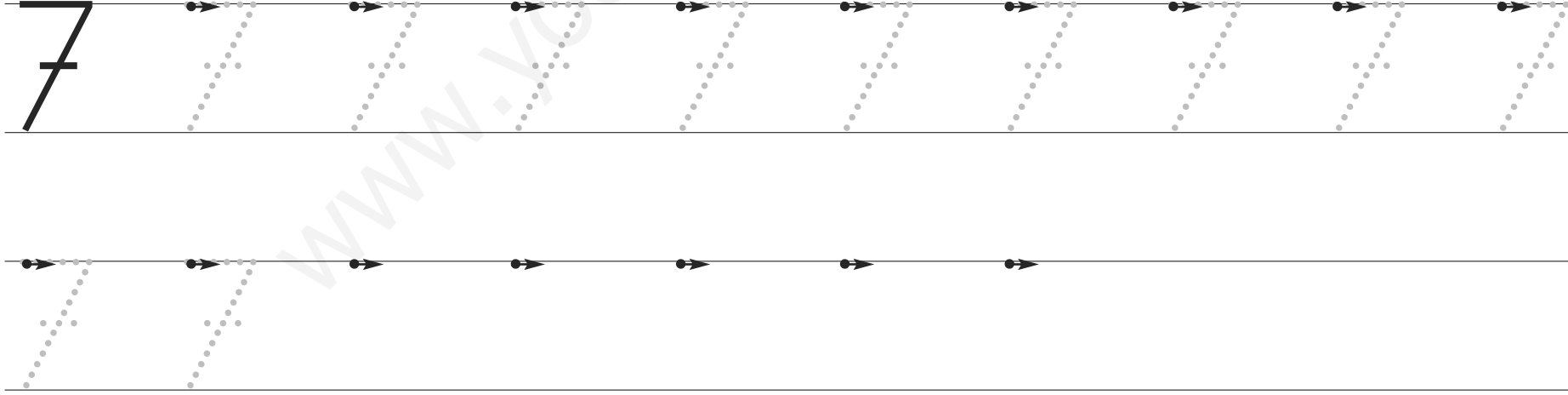



www.yoquieroaprobar.es

www.smvolteretas.com

