



# Mixed-ability worksheets

[www.yoquieroaprobar.es](http://www.yoquieroaprobar.es)

1 Complete. Use the correct form of the verb.

~~cut the grass~~ water the flowers plant seeds pick strawberries feed the birds  
make a window box eat a carrot dig a hole

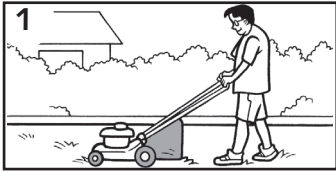

1 Sean is cutting  
the grass.



2 Rosie \_\_\_\_\_

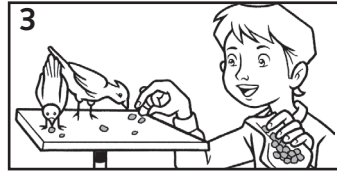

3 Andy \_\_\_\_\_



4 Karen \_\_\_\_\_



5 Helen \_\_\_\_\_



6 Sam \_\_\_\_\_

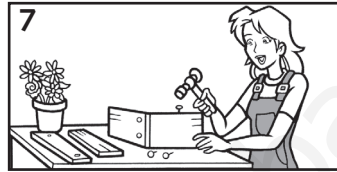

7 Mrs Roberts \_\_\_\_\_



8 Jason \_\_\_\_\_

2 Look and correct the sentences.



Ruth is feeding the birds.

Ruth isn't feeding the birds. She's feeding the dog.



Bob is planting seeds.



Iria is making a window box.



Jack is eating strawberries.



Amy is picking the flowers.



Dad is watering the grass.

1 Write.

a computer game a kite ~~a book~~ sandwiches a window box  
 football strawberries a magazine

a book

read

eat

make

play

2 Write.

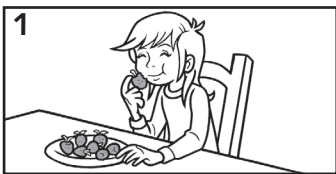

1 She's eating strawberries.



2 They're reading a magazine.

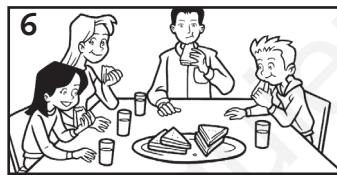

3 Look at the picture. Write questions.



Are they eating sandwiches?

Yes, they are.



Yes, she is.



Yes, they are.



Yes, he is.

1 Complete.

beautiful angry tall colourful dangerous small hard

1 The trees are

tall.

2 The man is

3 The flowers are

4 The bees are



5 His kite is

6 The rock is

7 The beetle is

2 Look at the picture. Write True or False.

1 The bee is more dangerous than the butterfly. True

2 The flowers are taller than the trees. \_\_\_\_\_

3 The man is angrier than the woman. \_\_\_\_\_

4 The boy's kite is more colourful than the girl's kite. \_\_\_\_\_

5 The flowers are more beautiful than the trees. \_\_\_\_\_

6 The rock is harder than the flowers. \_\_\_\_\_

3 Write about the pictures. Use the adjective in the correct form.

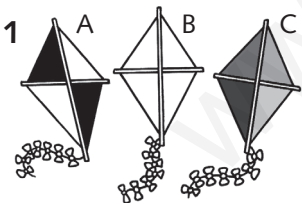

(colourful)  
C is the most  
colourful.

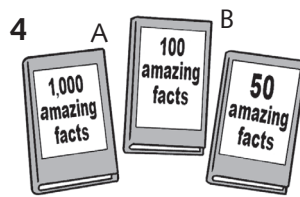

(useful)  
C \_\_\_\_\_  
\_\_\_\_\_

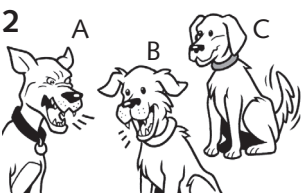

(angry)  
\_\_\_\_\_  
\_\_\_\_\_

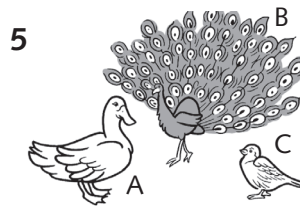

(beautiful)  
\_\_\_\_\_  
\_\_\_\_\_

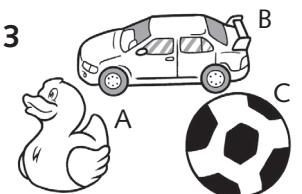

(hard)  
\_\_\_\_\_  
\_\_\_\_\_



(tall)  
\_\_\_\_\_  
\_\_\_\_\_



**1** Write.

nurse ~~cleaner~~ doctor shop assistant taxi driver ~~security guard~~ waitress musician



She's a security guard.



He's a cleaner.



**2** Complete the sentences. Use the verb in brackets in the correct form.

- 1 (wear a uniform) A security guard wears a uniform.  
 A musician doesn't wear a uniform.
- 2 (work in a café) A waitress \_\_\_\_\_  
 A postman \_\_\_\_\_
- 3 (work in a hospital) A teacher \_\_\_\_\_  
 A nurse \_\_\_\_\_

**3** Read and complete the information about Rosa and Dave. Write about Sue and Tom.

	job?	starts work?	works at weekends?	wears a uniform?	likes his/her uniform?	likes his/her job?
Rosa						
Sue	firefighter	7.00	yes	yes	yes	yes
Tom	postman	5.00	no	yes	no	no
Dave						

Rosa is a waitress. She starts work at nine o'clock and she works at weekends. She wears a uniform. She doesn't like her uniform. She likes her job.

Dave is a doctor. He starts work at two o'clock. He doesn't work at weekends. He doesn't wear a uniform. He likes his job.

1 Sue is \_\_\_\_\_  
 \_\_\_\_\_  
 \_\_\_\_\_  
 \_\_\_\_\_

2 Tom is \_\_\_\_\_  
 \_\_\_\_\_  
 \_\_\_\_\_  
 \_\_\_\_\_



1 Read and write *True* or *False*.

<input type="checkbox"/>	<input type="checkbox"/>	<input type="checkbox"/>	<input type="checkbox"/>	<input checked="" type="checkbox"/>
<input type="checkbox"/>	<input type="checkbox"/>	<input type="checkbox"/>	<input checked="" type="checkbox"/>	<input checked="" type="checkbox"/>
<input type="checkbox"/>	<input type="checkbox"/>	<input checked="" type="checkbox"/>	<input checked="" type="checkbox"/>	<input checked="" type="checkbox"/>
<input type="checkbox"/>	<input checked="" type="checkbox"/>	<input checked="" type="checkbox"/>	<input checked="" type="checkbox"/>	<input checked="" type="checkbox"/>
never	sometimes	often	usually	always

<p><b>Sally</b></p>	<p><b>Tom</b></p>	<p><b>Cathy</b></p>	<p><b>James</b></p>	<p><b>Eliza</b></p>
---------------------	-------------------	---------------------	---------------------	---------------------

- 1 Sally sometimes does her homework.  
False
- 2 Tom never does his homework.  
\_\_\_\_\_
- 3 Cathy sometimes does her homework.  
\_\_\_\_\_
- 4 James always does his homework.  
\_\_\_\_\_
- 5 Eliza usually does her homework.  
\_\_\_\_\_

2 Order the words. Then complete the chart for Tony.

- 1 Tony football always . plays Tony always plays football.
- 2 usually homework . He does his \_\_\_\_\_
- 3 to . goes park He the sometimes \_\_\_\_\_
- 4 never He . plays piano the \_\_\_\_\_
- 5 for pizza has lunch . often He \_\_\_\_\_
- 6 swimming goes He usually . \_\_\_\_\_

At the weekend	1	2	3	4	5	6
Tony	<u>always</u>					
You						

3 Complete the chart for you. Write.

- 1 I \_\_\_\_\_ 4 \_\_\_\_\_
- 2 \_\_\_\_\_ 5 \_\_\_\_\_
- 3 \_\_\_\_\_ 6 \_\_\_\_\_

1 Write the questions. Then look and answer.



- 1 laptop  
Has she got a laptop? Yes, she has.
- 2 charger  
\_\_\_\_\_
- 3 headphones  
\_\_\_\_\_
- 4 memory stick  
\_\_\_\_\_

2 What have you got? Answer for you. Use I've got and I haven't got.

mobile phone calculator DVD player ~~digital camera~~



I \_\_\_\_\_  
digital camera.

3 Read and write the names.

Paula	✓	✓	X	✓	✓	X
Rosa	X	✓	✓	X	✓	X
Lucy	✓	X	✓	X	X	✓
Amy	✓	X	X	✓	✓	✓

- 1 She hasn't got a computer or a memory stick. She's got a mobile phone and a digital camera. She hasn't got headphones. She's got a calculator. What's her name? Rosa
- 2 She's got a computer, but she hasn't got a memory stick. She's got a digital camera and headphones. She hasn't got a mobile phone or a calculator. What's her name?  
\_\_\_\_\_
- 3 She's got a computer and a memory stick. She's got a calculator and headphones. She hasn't got a mobile phone or a camera. What's her name? \_\_\_\_\_
- 4 She's got a computer and a memory stick. She hasn't got a digital camera or headphones. She's got a calculator. What's her name?  
\_\_\_\_\_

1 Complete.

books school the guitar ~~laptops~~ bikes television  
MP3 players pizza photos

- 1 have laptops
- 2 watch \_\_\_\_\_
- 3 play \_\_\_\_\_
- 4 read \_\_\_\_\_
- 5 eat \_\_\_\_\_
- 6 go to \_\_\_\_\_
- 7 ride \_\_\_\_\_
- 8 take \_\_\_\_\_
- 9 listen to \_\_\_\_\_

2 Look at the picture of life in the Stone Age. Find 8 mistakes and write.

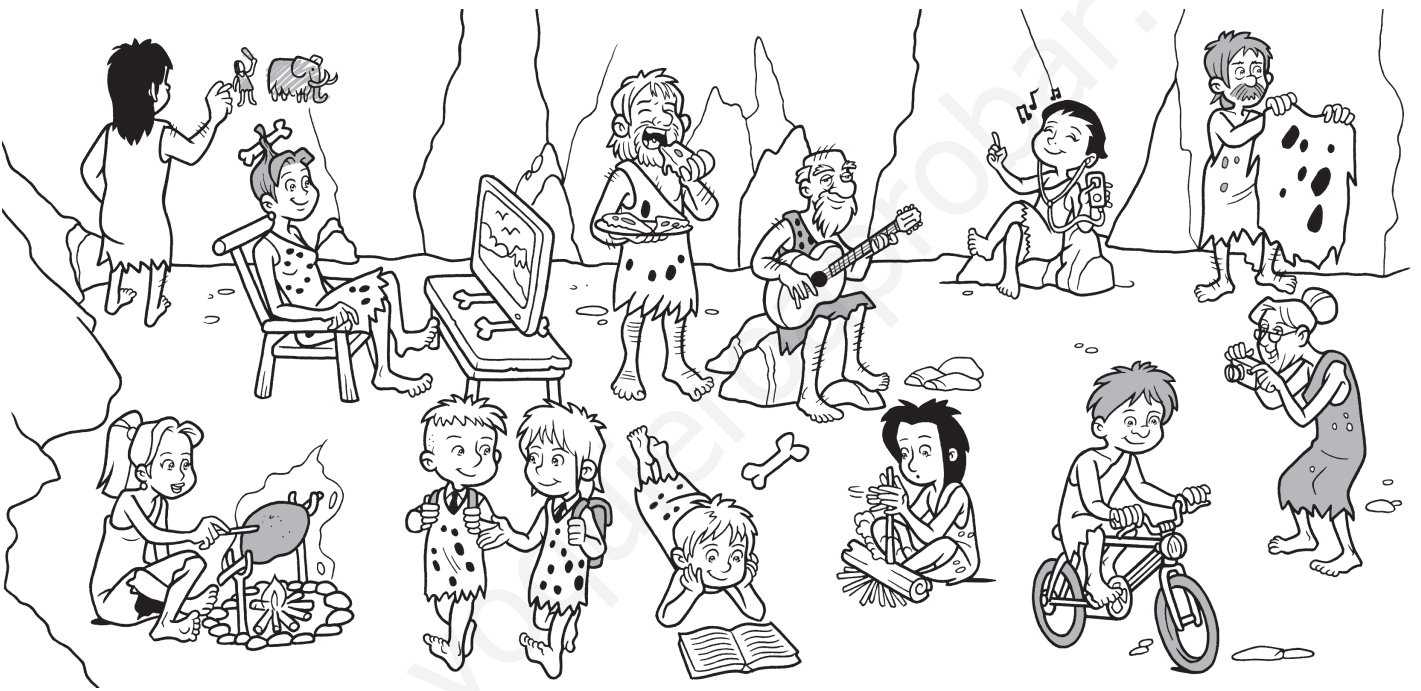

- 1 They didn't eat pizza.
- 2 \_\_\_\_\_
- 3 \_\_\_\_\_
- 4 \_\_\_\_\_
- 5 \_\_\_\_\_
- 6 \_\_\_\_\_
- 7 \_\_\_\_\_
- 8 \_\_\_\_\_

3 Compare your life with life in the Stone Age. Write.

- 1 I learn English. They didn't learn English.
- 2 \_\_\_\_\_
- 3 \_\_\_\_\_
- 4 \_\_\_\_\_
- 5 \_\_\_\_\_



1 Complete the table.

Infinitive	Past form	Infinitive	Past form	Infinitive	Past form
ride	rode		made	use	
	ate	drink			watched
paint			gave	buy	
	had	go			lived
see			played		

2 Complete the sentences with verbs from activity 1. Then write *U* (Ugg), *S* (Steve) or *B* (both).

Ugg



- He lived in a cave. U
- He played with his brothers and sisters. \_\_\_\_\_
- He \_\_\_\_\_ his bike. \_\_\_\_\_
- He \_\_\_\_\_ television. \_\_\_\_\_
- He \_\_\_\_\_ a mammoth for a pet. \_\_\_\_\_

Steve



- He \_\_\_\_\_ beautiful pictures on the cave walls. \_\_\_\_\_
- He \_\_\_\_\_ to school. \_\_\_\_\_
- He \_\_\_\_\_ food at the supermarket. \_\_\_\_\_
- He \_\_\_\_\_ meat, fruit and vegetables. \_\_\_\_\_
- He \_\_\_\_\_ water. \_\_\_\_\_

3 Write some more sentences about Steve when he was a boy.

the Queen    football for England    two sisters    a book    a computer    at 34 Park Road



(live) He lived at  
34 Park Road.



(have) \_\_\_\_\_

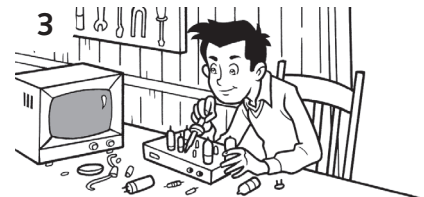

(make) \_\_\_\_\_



(see) \_\_\_\_\_



(write) \_\_\_\_\_



(play) \_\_\_\_\_



1 Write.

visited went made went gave had ~~met~~ wore saw had wrote bought

a good time to the shops a milkshake a film a T-shirt some jeans a pizza  
for a walk an art gallery an e-mail a present to Sue ~~a friend~~

Alice, Tom and Joe were busy last Saturday.



1 Alice met a friend.



2 She \_\_\_\_\_



3 \_\_\_\_\_



4 \_\_\_\_\_

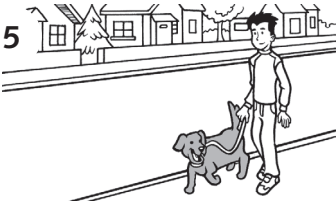

5 Tom \_\_\_\_\_

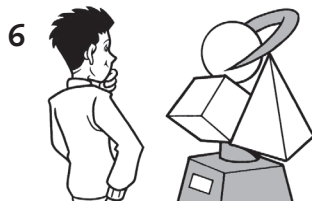

6 \_\_\_\_\_



7 \_\_\_\_\_



8 \_\_\_\_\_



9 Joe \_\_\_\_\_



10 \_\_\_\_\_



11 \_\_\_\_\_



12 \_\_\_\_\_

2 Answer.

- 1 Did Alice go to the shops? Yes, she did.
- 2 Did Tom buy some jeans? \_\_\_\_\_
- 3 Did Joe have a good time? \_\_\_\_\_
- 4 Did Alice visit an art gallery? \_\_\_\_\_
- 5 Did Tom have a milkshake? \_\_\_\_\_
- 6 Did Joe make a pizza? \_\_\_\_\_
- 7 Did Alice see a film? \_\_\_\_\_
- 8 Did Tom write an e-mail? \_\_\_\_\_

3 Write some more questions about Alice, Tom and Joe.

- 1 \_\_\_\_\_ ? Yes, she did.
- 2 \_\_\_\_\_ ? Yes, he did.
- 3 \_\_\_\_\_ ? No, she didn't.
- 4 \_\_\_\_\_ ? Yes, he did.

**1** Choose three answers for each question.

my friend ~~to the shops~~ an ice cream to the cinema some popcorn  
my cousin my mum some shoes to the beach

Where did you go?
to the shops

Who did you meet?

What did you buy?

**2** Complete the dialogues. Use the words in activity 1. Use the verbs in the correct form.



1 Where did you go?  
*I went to the cinema.*

2 Who did you meet?  
\_\_\_\_\_

3 What did you buy?  
\_\_\_\_\_



4 Where did you go?  
\_\_\_\_\_

5 Who did you meet?  
\_\_\_\_\_

6 What did you buy?  
\_\_\_\_\_



7 Where \_\_\_\_\_?  
I went to the beach.

8 Who \_\_\_\_\_?  
I met my cousin.

9 What \_\_\_\_\_?  
I bought an ice cream.

**3** Think about a day in your life. Draw pictures and complete the dialogues.

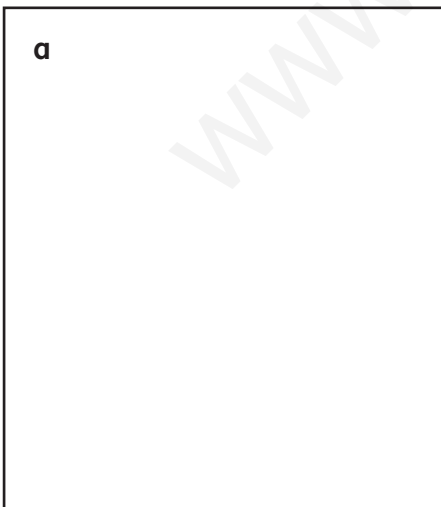

Where \_\_\_\_\_?  
\_\_\_\_\_

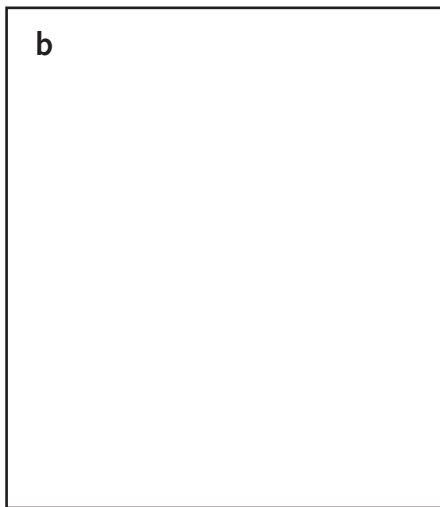

Who \_\_\_\_\_?  
\_\_\_\_\_

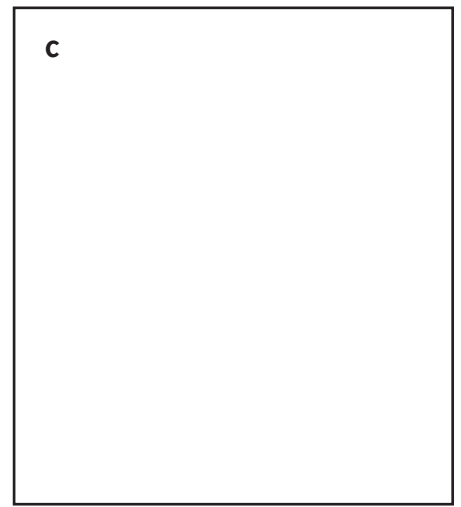

What \_\_\_\_\_?  
\_\_\_\_\_

1 Find nine more verbs and their Past Simple forms.

g	b	u	y	p	e	m	r
i	n	a	k	d	e	a	t
v	s	k	w	r	o	k	a
e	e	w	r	i	t	e	k
s	e	a	w	n	a	v	e
h	a	v	e	k	e	g	o

b	m	a	d	e	d	e	g
o	n	t	u	a	r	g	a
u	k	e	b	h	a	d	v
g	w	e	n	t	n	s	e
h	t	o	o	k	k	a	o
t	w	r	o	t	e	w	r

2 Read and complete with the correct form of the verbs.



One day Jason (go ✓) <sup>1</sup> went for a swim in the river in the woods. He (see ✓) <sup>2</sup> \_\_\_\_\_ a monster. He (jump ✓) <sup>3</sup> \_\_\_\_\_ out of the water and he (run ✓) <sup>4</sup> \_\_\_\_\_ home. He (take ✗) <sup>5</sup> didn't take his clothes with him! He (tell ✓) <sup>6</sup> \_\_\_\_\_ his mum about the monster. She was angry. 'Go and find your clothes!' she said.

Jason (have ✓) <sup>7</sup> \_\_\_\_\_ an idea. He (walk ✓) <sup>8</sup> \_\_\_\_\_ back to the woods with his digital camera. He (see ✓) <sup>9</sup> \_\_\_\_\_ the monster again, but he wasn't scared – he was surprised! He (run ✗) <sup>10</sup> \_\_\_\_\_. He (climb ✓) <sup>11</sup> \_\_\_\_\_ a tree and he (wait ✓) <sup>12</sup> \_\_\_\_\_. The monster (walk ✓) <sup>13</sup> \_\_\_\_\_ under the tree. Jason (take ✓) <sup>14</sup> \_\_\_\_\_ a photo. The monster (see ✓) <sup>15</sup> \_\_\_\_\_ the flash and (disappear ✓) <sup>16</sup> \_\_\_\_\_.

Jason said, 'Look at the photo. The monster is wearing my clothes!' Jason's mum was very surprised! Jason (give ✗) <sup>17</sup> \_\_\_\_\_ the photo to his mum. He put it on his wall. Then he (write ✓) <sup>18</sup> \_\_\_\_\_ an e-mail to his friend John about his adventure with the monster.

3 Read the story again. Number the pictures.

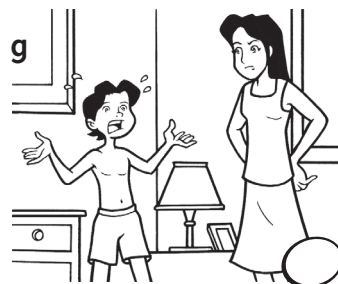

1 Write.

mix the lemonade fry the onions peel the lemons bake the pizza  
~~chop the tomatoes~~ weigh the sugar boil the water add the cheese



1 chop the tomatoes

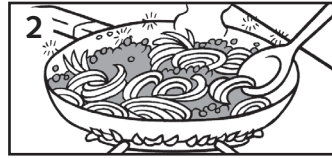

\_\_\_\_\_



\_\_\_\_\_

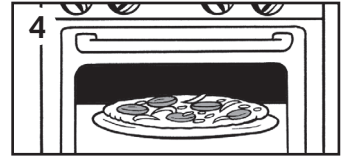

\_\_\_\_\_

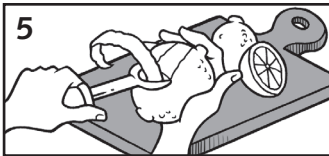

\_\_\_\_\_

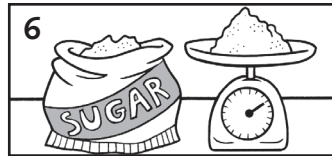

\_\_\_\_\_

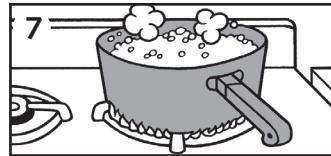

\_\_\_\_\_

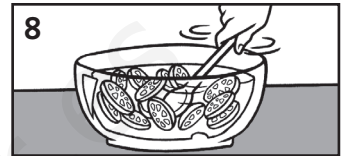

\_\_\_\_\_

2 Look and write. Use *She's got ...* and *She needs ...*

Vegetable and pasta soup

- 3 carrots
- 2 tomatoes
- 2 onions
- 100g pasta
- 100g meat
- 1l water



1 *She's got carrots.*

4 \_\_\_\_\_

2 \_\_\_\_\_

5 \_\_\_\_\_

3 \_\_\_\_\_

6 \_\_\_\_\_

3 Abbie wants to help her mum make bread and soup. Look and write.



1 I want to mix the flour and water.

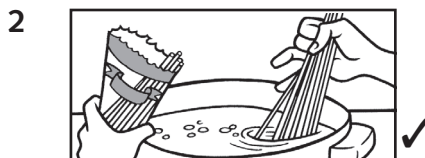

2 \_\_\_\_\_



3 I don't want to \_\_\_\_\_



4 \_\_\_\_\_

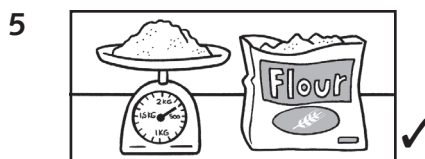

5 \_\_\_\_\_



6 \_\_\_\_\_



1 Read the recipe. Correct the mistakes.

How to make a banana milkshake



First you have to wash the bananas.

First you have to peel the bananas.



Then you have to chop the onions.

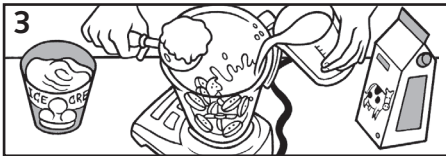

Then you have to add water and sugar.

\_\_\_\_\_

\_\_\_\_\_

\_\_\_\_\_

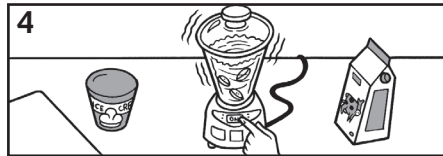

Then you have to boil the milkshake.

\_\_\_\_\_

\_\_\_\_\_

\_\_\_\_\_



Then you have to add the strawberries.

\_\_\_\_\_

\_\_\_\_\_

\_\_\_\_\_

2 Look and write about how to make a strawberry milkshake.

add mix add ~~wash~~

milk sugar milkshake ~~strawberries~~ ice cream



1 First you have to wash the strawberries.

2 \_\_\_\_\_

3 \_\_\_\_\_



4 \_\_\_\_\_

3 Look at the recipes in activities 1 and 2 and write questions and answers.

Yolanda wants to make a strawberry milkshake.

1  Do I have to wash the strawberries? Yes, you do.

2  \_\_\_\_\_ No, you don't.

3  \_\_\_\_\_ Yes, you do.

Robert wants to make a banana milkshake.

4  Do I have to peel the bananas? Yes, you do.

5  Do I have to boil the milk? \_\_\_\_\_

6  Do I have to add sugar? \_\_\_\_\_





1 Write.

~~waterfall~~ river island beach rock cliff hill cave mountain wood

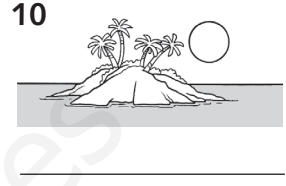
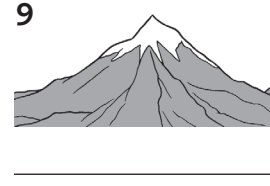
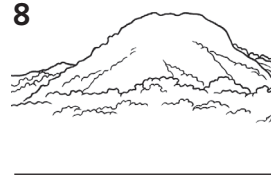
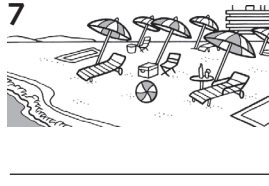
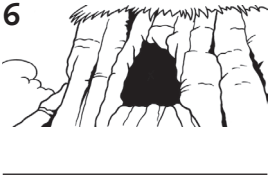
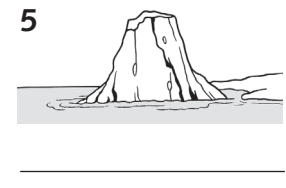
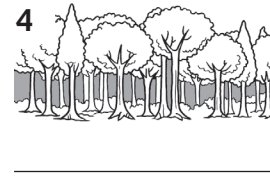
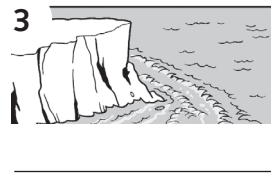
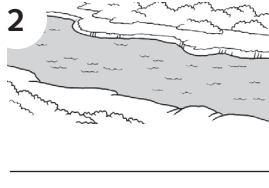

2 Compare the places. Write eight things that are different in picture B.

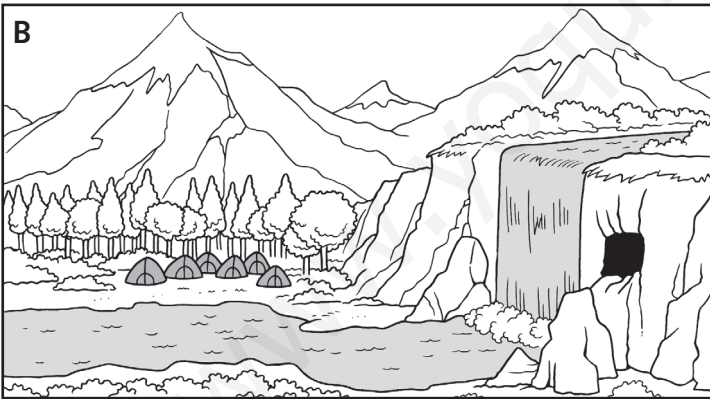
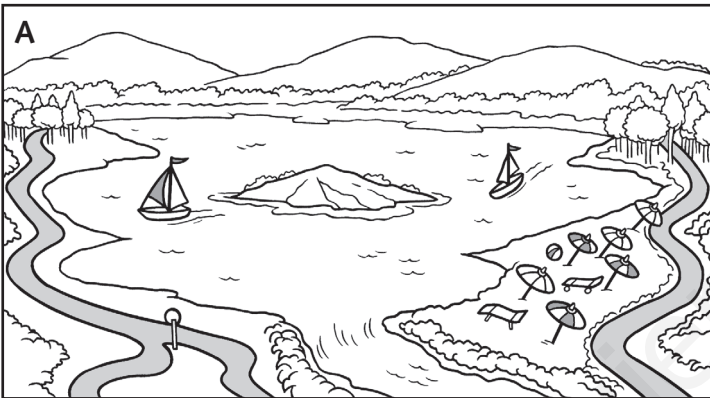

There's a... There are some...  
There isn't a... There aren't any...

- 1 There aren't any hills.
- 2 \_\_\_\_\_
- 3 \_\_\_\_\_
- 4 \_\_\_\_\_
- 5 \_\_\_\_\_
- 6 \_\_\_\_\_
- 7 \_\_\_\_\_
- 8 \_\_\_\_\_

3 Read and write A or B. Then write four more questions about the pictures.

- |  |  |
|--|--|
| 1 Are there any hills?<br>Yes, there are. Picture <u>A</u> | 5 _____<br>Yes, there is. Picture A    |
| 2 Is there a cave?<br>Yes, there is. Picture _____         | 6 _____<br>Yes, there are. Picture B   |
| 3 Are there any rocks?<br>No, there aren't. Picture _____  | 7 _____<br>No, there aren't. Picture A |
| 4 Is there a waterfall?<br>No, there isn't. Picture _____  | 8 _____<br>No, there isn't. Picture B  |

1 Complete.

a mountain homework an e-mail a bike  
in the park in a lake ~~television~~ in my bed

- 1 watch television
- 2 do \_\_\_\_\_
- 3 swim \_\_\_\_\_
- 4 sleep \_\_\_\_\_

- 5 climb \_\_\_\_\_
- 6 run \_\_\_\_\_
- 7 ride \_\_\_\_\_
- 8 read \_\_\_\_\_

2 Read and answer.



Amy

Amy is going to climb a mountain. She's going to sleep in a tent. She isn't going to play computer games. She's going to read books.



Clare

Clare is going to visit her grandparents. She's going to read books and play computer games. She's going to play volleyball.



Grace

Grace is going to go to the beach. She isn't going to sleep in a tent. She's going to swim in the sea and play volleyball.



Fiona

Fiona is going to go camping. She's going to sleep in a tent. She's going to swim in a river.

- 1 Who's going to sleep in a tent and swim? Fiona
- 2 Who's going to sleep in a tent and read books? \_\_\_\_\_
- 3 Who's going to play volleyball and swim? \_\_\_\_\_
- 4 Who's going to read books and play volleyball? \_\_\_\_\_

3 Write about what Ben and Jackie are going to do tomorrow.

**Ben**

**Jackie**

- 1 Ben is going to read a book.
- 2 He isn't going to \_\_\_\_\_
- 3 \_\_\_\_\_
- 4 \_\_\_\_\_

- 5 Jackie \_\_\_\_\_
- 6 \_\_\_\_\_
- 7 \_\_\_\_\_
- 8 \_\_\_\_\_

1 Write.

go sailing do card tricks ~~design a web page~~ go canoeing juggle  
make cakes go scuba diving

What are you going to do at summer camp?

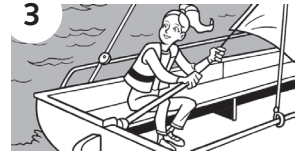

4

5

6

7



1 I'm going to design a web page.

5 \_\_\_\_\_

2 \_\_\_\_\_

6 \_\_\_\_\_

3 \_\_\_\_\_

7 \_\_\_\_\_

4 \_\_\_\_\_

2 Read and write the names. Then write two more dialogues about the other people.

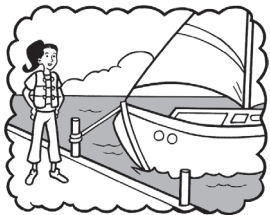

Ella



Paul

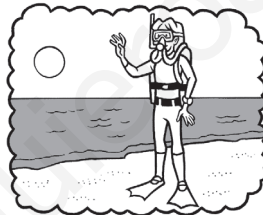

Sandra

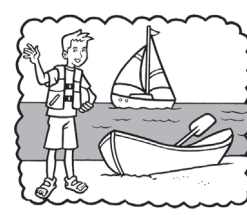

Tom

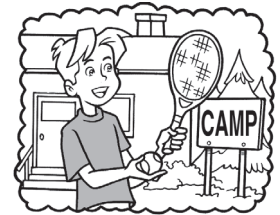

Jamie

1

Where are you going to go?  
I'm going to go to the beach.

What are you going to do?  
I'm going to go canoeing.  
Tom

2

Where are you going to go?  
I'm going to go to the beach.

What are you going to do?  
I'm going to go scuba diving.

3

Where are you going to go?  
I'm going to go to summer camp.

What are you going to do?  
I'm going to do card tricks.

4

\_\_\_\_\_

\_\_\_\_\_

\_\_\_\_\_

\_\_\_\_\_

5

\_\_\_\_\_

\_\_\_\_\_

\_\_\_\_\_

\_\_\_\_\_

1 Use a dictionary to find the words. Write. **D**

broccoli aubergine ~~cabbage~~ cauliflower bean mushroom

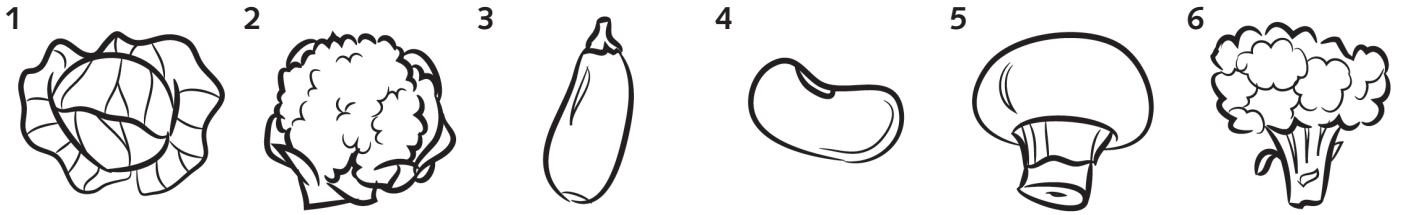

cabbage

2 Use a dictionary to find the words. Write. **D**

lemon ~~cherries~~ apricot grapes pineapple watermelon

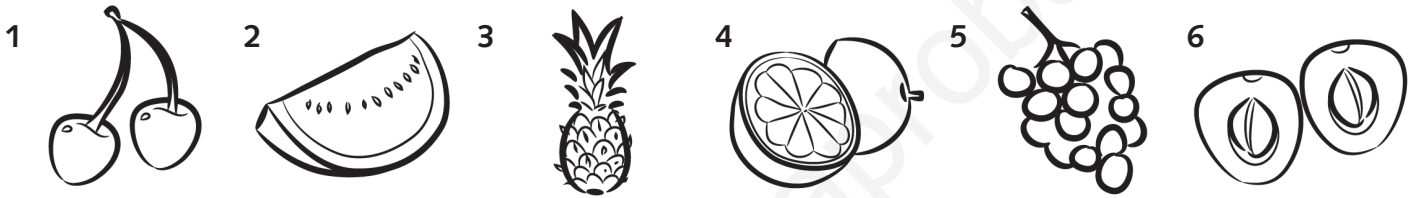

cherries

3 Read and write. Then draw and write two sentences about you.

1  His favourite fruit  
is cherries.

4  Her favourite  
vegetable is broccoli.

2 

5 

3 

6 

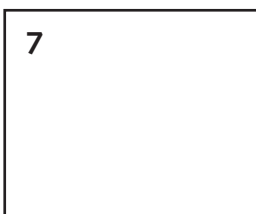
7  My

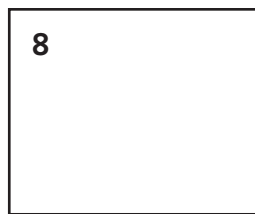
8  My

**1** Look and write 1, 2 or 3.



- a  What are the dogs doing?  
 They're playing.  3
- b  What's he doing?  
 He's sleeping.  0
- c  What's she doing?  
 She's riding a bike.  0
- d  Which is the most useful bag?  
 The big bag.  0
- e  Which dog is bigger, the black dog or the white dog?  
 The black dog.  0
- f  Which is the biggest butterfly?  
 The black one.  0

**2** Write questions for your friend to answer. Use all the pictures. Then practise the dialogues.

- 1 *In picture 2, what's the boy doing?*  
 \_\_\_\_\_  
 \_\_\_\_\_
- 2 \_\_\_\_\_  
 \_\_\_\_\_
- 3 \_\_\_\_\_  
 \_\_\_\_\_
- 4 *In picture 3, who is taller, the girl or the boy?*  
 \_\_\_\_\_  
 \_\_\_\_\_
- 5 \_\_\_\_\_  
 \_\_\_\_\_
- 6 \_\_\_\_\_  
 \_\_\_\_\_



In picture 1, what are the dogs doing?



They're digging a hole.



1 Read the blog posts. Number the missing sentences.



**Amy**

We went to the Butterfly and Insect Farm yesterday. We had a great time and we saw lots of mini-beasts! Here are our photos!

More than 500 butterflies live there. It's perfect for them. (1) I love butterflies. I think the Swallowtail is the most beautiful butterfly here. You can see the butterfly feeding table in this picture. (2) The butterflies are drinking the juice from the fruit. They love it!



**Simon**

This is the Spider Safari. They've got more than 50 different spiders here including some enormous tarantulas! I don't like spiders very much – I'm a bit scared. They aren't dangerous. (3) They aren't moving – I think they're sleeping. My brother loves spiders and I'm taking lots of photos for him. His favourite is the Goliath bird-eating spider. (4) It isn't eating a bird in the photos – thank goodness!

- a They're all in glass cages.  c There are lots of their favourite plants and flowers.   
 b It's the biggest spider in the world.  d It's got pieces of apple and orange on it.

2 Read again and answer the questions for each blog post.

	Amy	Simon
1 Where are they?		
2 How many animals live there?		
3 How do they feel about the butterflies/spiders?		
4 What are the butterflies/spiders doing in the photo?		
5 Which is Amy's/Simon's brother's favourite butterfly/spider?		

3 Write a blog post.

- Imagine you are visiting a Mini-beast Farm. Find a picture of a mini-beast.
- Imagine you are looking at the mini-beast. Answer the questions and make notes.

– Where are you?	– What are you doing?
– How many mini-beasts live there?	– What is your mini-beast doing?
– How do you feel?	– Do you know any interesting information about it?

- Use your notes to write a blog post.
- Check your work carefully.
- Write out the corrected text and draw a picture.



**1** Use a dictionary to find the words. Write. **D**

vet flight attendant cameraman mechanic secretary factory worker



**2** Match. Add two more sentences about different jobs. **D**

- |   |               |
|---|---------------|
| 1 A vet works in <input checked="" type="radio"/> e | a an airport  |
| 2 A factory worker works in <input type="radio"/>   | b a TV studio |
| 3 A secretary works in <input type="radio"/>        | c a factory   |
| 4 A mechanic works in <input type="radio"/>         | d a garage    |
| 5 A flight attendant works in <input type="radio"/> | e a clinic    |
| 6 A cameraman works in <input type="radio"/>        | f an office   |
| 7 _____   |               |
| 8 _____   |               |

**3** Complete each word spider with three more jobs. **D**

a receptionist \_\_\_\_\_

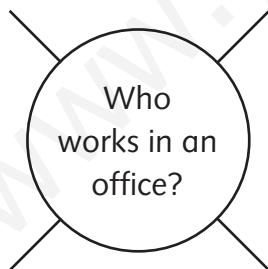

\_\_\_\_\_ a doctor

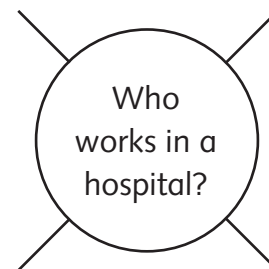

**4** Complete the sentences for you. **D**

- I want to be a \_\_\_\_\_
- I don't want to be a \_\_\_\_\_ or a \_\_\_\_\_
- I want to work in a \_\_\_\_\_
- I don't want to work in a \_\_\_\_\_ or a \_\_\_\_\_

1 Look. Complete the questions. Choose ✓ the correct answers.



- 1 Where does he work?
  - a He usually works at the zoo.
  - b He usually works in a school.
- 2 What animals \_\_\_\_\_?
  - a He never looks after the snakes.
  - b He always looks after the snakes.
- 3 What \_\_\_\_\_?
  - a He sometimes wears a white or green jacket.
  - b He sometimes wears a black and white jacket and a hat.

2 Write the answers. fruit and vegetables in the shed 3,000 kilos at ten o'clock ~~Africa~~

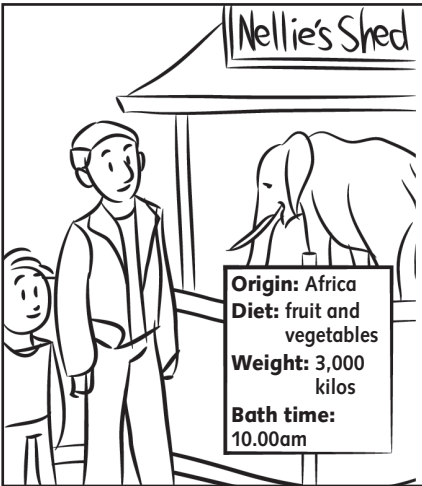

- 1 Where does Nellie come from?  
She comes from Africa.
- 2 What does she eat?  
\_\_\_\_\_
- 3 Where does she sleep?  
\_\_\_\_\_
- 4 What does she weigh?  
\_\_\_\_\_
- 5 What time does she have a bath?  
\_\_\_\_\_

3 Read and circle the correct words.

Koalas live in one country in the world – Australia. All koalas are grey. A lot of people call them koala bears, but they’re not bears. They’re marsupials – these are animals that have a pouch to carry their babies in, like kangaroos and wallabies. Koala mothers carry

their babies in their pouch until they’re about six months old. Koalas eat eucalyptus leaves. They don’t like leaves from other types of trees. They get food and liquid from the eucalyptus leaves, so they don’t drink a lot of water. Koalas like to sleep. They sleep for 18–20 hours a day!

- 1 You **usually** / **never** find koalas in Europe.
- 2 Koalas are **usually** / **always** grey.
- 3 People **often** / **always** call them koala bears.
- 4 Koalas **sometimes** / **always** have a pouch to carry their babies.
- 5 Koalas **always** / **never** eat leaves from eucalyptus trees.
- 6 Koalas **never** / **sometimes** drink water.
- 7 They **sometimes** / **usually** sleep for 18–20 hours a day.

**1 Read. Write the headings for the paragraphs.** **D**

Lu's job    Amazing bears    A safe place

1 \_\_\_\_\_

There are about 1,500 wild panda bears in China. They don't live in any other part of the world. There are sanctuaries in China because pandas are in danger of extinction. Pandas only eat bamboo, but the bamboo forests are disappearing. Pandas need about 13.5 kilos of bamboo every day! Pandas eat bamboo for about 16 hours every day. When a panda isn't eating, it sleeps.

2 \_\_\_\_\_

The sanctuary is a special place. Scientists study and look after pandas there. In the future they want to put the pandas back in the bamboo forests. When baby pandas are born they weigh



about 100 grams. They're tiny! Scientists look after them very carefully.

By Chinese tradition they give the baby pandas a name when they're 100 days old.

3 \_\_\_\_\_

Lu is a teacher and a tourist guide at the sanctuary. Tourists, school children and Chinese families visit the sanctuary. Lu teaches them about pandas. She loves her job. She thinks it's very important to teach people about conservation.

**2 Read again. Answer the questions.**

- 1 Where do pandas live? In China.
- 2 What do pandas eat? \_\_\_\_\_
- 3 How many hours does a panda bear sleep?  
\_\_\_\_\_
- 4 How much does a baby panda bear weigh?  
\_\_\_\_\_
- 5 When do they give baby pandas a name?  
\_\_\_\_\_
- 6 What's Lu's job?  
\_\_\_\_\_
- 7 Where does she work?  
\_\_\_\_\_
- 8 What does Lu do?  
\_\_\_\_\_
- 9 Does she like her job?  
\_\_\_\_\_
- 10 What does she think is important?  
\_\_\_\_\_

**3 Find out about other animals in danger. Write an article about a sanctuary.**

- 1 Choose an animal in danger, for example: tiger, orangutan, chimpanzee, gorilla, lynx, bear.
- 2 Find out about your animal. Write notes.
  - Where do they live?
  - Why are they in danger?
  - What do they eat?
  - What interesting facts do you know?
- 3 Find out about sanctuaries for your animal. Write notes.
  - Where is the sanctuary?
  - What do they do at the sanctuary?
  - Why is it important?
- 4 Use your notes to write about your animal and the sanctuary.

**1** Read and label the picture. **D**

There are three grey screens.  
 One mouse is grey, one is black and one is white.  
 There are three keyboards.  
 One keyboard is black, two keyboards are grey.  
 The printer is white.  
 The scanner is black.  
 There are six speakers.

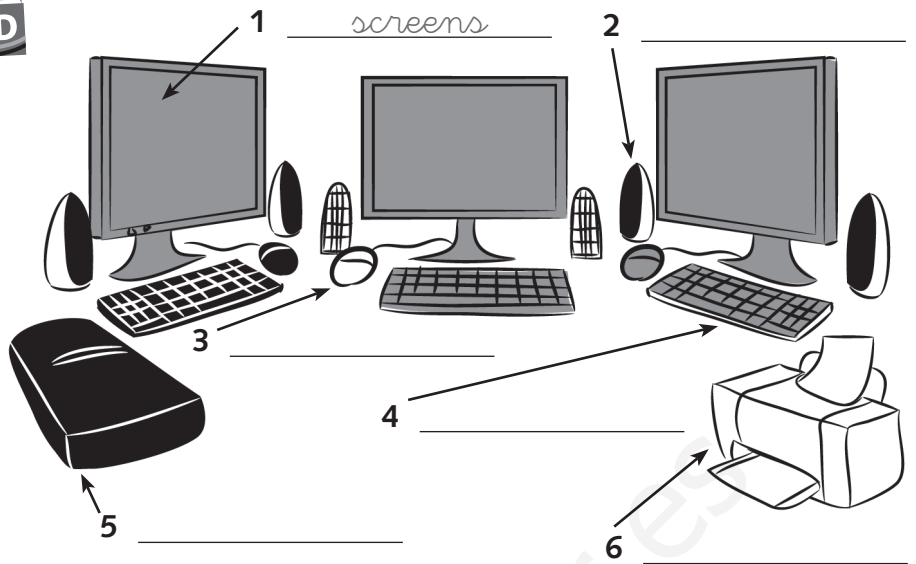

**2** Answer.



- 1 What colour is the screen? white
- 2 What colour is the keyboard? \_\_\_\_\_
- 3 What colour is the mouse? \_\_\_\_\_
- 4 What colour is the printer? \_\_\_\_\_
- 5 What colour is the scanner? \_\_\_\_\_
- 6 What colour are the speakers? \_\_\_\_\_

**3** Write about your computer.

---



---



---



---

**4** Match the instructions with the icons. Then use the underlined words to label the icons.

	<input checked="" type="radio"/>	<u>print</u>
	<input type="radio"/>	_____
	<input type="radio"/>	_____

	<input type="radio"/>	_____
	<input type="radio"/>	_____
	<input type="radio"/>	_____

- |   |   |
|---|---|
| <p><b>a</b> Click here to <u>copy</u> some text.</p> <p><b>b</b> Click here to <u>paste</u> some text into your document.</p> <p><b>c</b> Click here to <u>open</u> a new document.</p> | <p><b>d</b> Click here if you want to <u>print</u> a document.</p> <p><b>e</b> Click here to <u>delete</u> some text.</p> <p><b>f</b> Click here if you want to <u>save</u> a document.</p> |
|---|---|

**1** Complete the crossword with the past form of the verbs.

- 1 read
- 2 live
- 3 eat
- 4 ride
- 5 wear
- 6 play
- 7 listen
- 8 take
- 9 paint

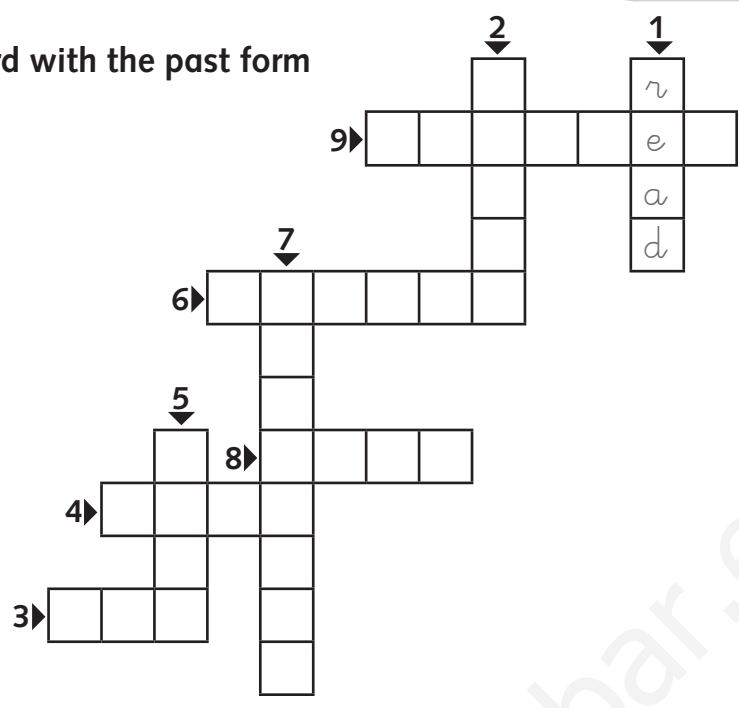

**2** Write about life in the Middle Ages. Use the verbs in activity 1.

~~tomatoes~~ meat and vegetables flats ~~small houses~~ horses jeans  
 tunics chess to MP3 players photos pictures comics

The Middle Ages was a long period of history, from around 476 to 1492. Life was very different in the Middle Ages.

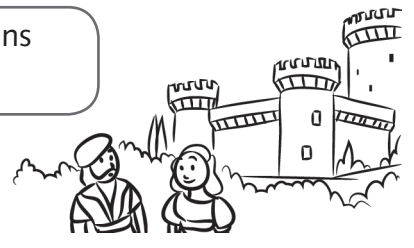

They didn't eat  
 tomatoes.



\_\_\_\_\_



They lived in  
 small houses.



\_\_\_\_\_

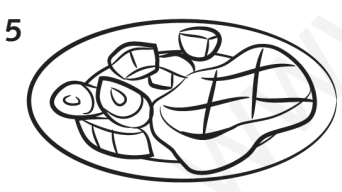

\_\_\_\_\_



\_\_\_\_\_



\_\_\_\_\_



\_\_\_\_\_



\_\_\_\_\_

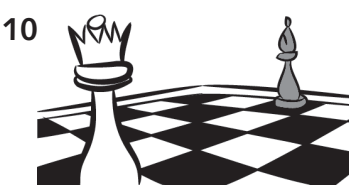

\_\_\_\_\_



\_\_\_\_\_



\_\_\_\_\_

**1** Read and write the headings on the Medieval Town leaflet.

Go shopping!

Lessons for boys

Paint like a monk!

Listen to medieval music!

**Welcome to the Living Museum. Visit the Medieval Town and discover life in the Middle Ages!**

1 Listen to medieval music!

Monks lived in monasteries. Visit the church and listen to the monks singing. The monks went to church eight times a day!



**Monks**

2 \_\_\_\_\_

The Medieval school was just for boys – girls didn't go to school in the Middle Ages. They learned to read and write. They didn't study Music or do PE. They studied Mathematics and learned Latin and Greek too.



3 \_\_\_\_\_



The monks made beautiful books in the monastery. They didn't have computers or printers, so they wrote the books by hand. They also decorated the books with very beautiful pictures.

4 \_\_\_\_\_

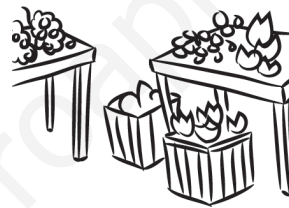

They didn't have supermarkets in the Middle Ages. People went to the market for fruit, meat and vegetables. Are you hungry? Have lunch in our medieval market.

**2** Read again. Write *church, monastery, school or market*.

**Notes for the Medieval Town**

1 You can buy toys here. market

5 Girls didn't go here. \_\_\_\_\_

2 Monks sang songs here. \_\_\_\_\_

6 You can have lunch here. \_\_\_\_\_

3 Monks decorated books here. \_\_\_\_\_

7 People bought fruit here. \_\_\_\_\_

4 You can hear singing here. \_\_\_\_\_

8 Boys learned Greek here. \_\_\_\_\_

**3** Write a leaflet for the Roman Town at the Living Museum.

- 1 Use the notes for the Roman Town.
- 2 Write your text.
- 3 Illustrate your leaflet.

**Notes for the Roman town**

**The baths:** different rooms for men and women; good place to meet your friends in the centre of town

**The forum:** shops; meeting place – like an office

**The school:** girls didn't go; boys studied Latin, Greek, Maths; lessons sometimes outside

**The restaurant:** olives and honey; water and wine



1 Complete with two words.

the police   some money   ~~a poem~~   an e-mail   notes   a bike   hello   a horse  
 a race   Maths   a door   a book   History   ~~a ball~~   a friend   a match

- 1 say a poem / \_\_\_\_\_
- 2 open \_\_\_\_\_ / \_\_\_\_\_
- 3 write \_\_\_\_\_ / \_\_\_\_\_
- 4 ride \_\_\_\_\_ / \_\_\_\_\_
- 5 win \_\_\_\_\_ / \_\_\_\_\_
- 6 find a ball / \_\_\_\_\_
- 7 study \_\_\_\_\_ / \_\_\_\_\_
- 8 phone \_\_\_\_\_ / \_\_\_\_\_

2 Write the Past Simple form of the verbs. Use a dictionary. 

Infinitive	Past Simple form	Infinitive	Past Simple form
say	<i>said</i>	win	
open		find	
write		study	
ride		phone	

3 Colour the regular verbs green and the irregular verbs red.

4 Read and write *True* or *False* for you. Then write five more true sentences.

- 1 I didn't find any money in the street yesterday. \_\_\_\_\_
- 2 I rode my bike yesterday. \_\_\_\_\_
- 3 I won a match at the weekend. \_\_\_\_\_
- 4 I didn't study Maths at the weekend. \_\_\_\_\_
- 5 I phoned my granny yesterday. \_\_\_\_\_
- 6 \_\_\_\_\_
- 7 \_\_\_\_\_
- 8 \_\_\_\_\_
- 9 \_\_\_\_\_
- 10 \_\_\_\_\_

1 Read and answer. 1 Who is the story about? 2 What doesn't she like? 3 Who is Sue?

2 Read again. Complete with the correct form of the verbs.



Elsa (like ) <sup>1</sup> didn't like going to museums, but her parents (love ) <sup>2</sup> loved them. When they (go ) <sup>3</sup> \_\_\_\_\_ on holiday, they (go ) <sup>4</sup> \_\_\_\_\_ to the beach and they (climb ) <sup>5</sup> \_\_\_\_\_ mountains. They (go ) <sup>6</sup> \_\_\_\_\_ to museums!

Last summer they (visit ) <sup>7</sup> \_\_\_\_\_ a dinosaur museum. Her parents (stop ) <sup>8</sup> \_\_\_\_\_ by every skeleton. Her mum (read ) <sup>9</sup> \_\_\_\_\_ the information and her dad

(take ) <sup>10</sup> \_\_\_\_\_ photos. Elsa (want ) <sup>11</sup> \_\_\_\_\_ to learn about dinosaurs. 'They're boring', she (think ) <sup>12</sup> \_\_\_\_\_. 'They (live ) <sup>13</sup> \_\_\_\_\_ millions of years ago.' She (watch ) <sup>14</sup> \_\_\_\_\_ a video about dinosaurs as she (wait ) <sup>15</sup> \_\_\_\_\_ for her parents. It was the story of a T. Rex and a woman called Sue. Sue Hendrickson (discover ) <sup>16</sup> \_\_\_\_\_ the skeleton in South Dakota, USA.

Later that year Elsa was in the school team in a TV quiz show. It was the last question.

Elsa's team (have ) <sup>17</sup> \_\_\_\_\_ 29 points and the other team (have ) <sup>18</sup> \_\_\_\_\_ 29 points too. The quiz master (ask ) <sup>19</sup> \_\_\_\_\_ the question: 'Where did Sue Hendrickson discover the famous T. Rex?' The other team (know ) <sup>20</sup> \_\_\_\_\_. Elsa's team (know ) <sup>21</sup> \_\_\_\_\_. Then suddenly Elsa (remember ) <sup>22</sup> \_\_\_\_\_ the video. She (push ) <sup>23</sup> \_\_\_\_\_ the answer button – and they (win ) <sup>24</sup> \_\_\_\_\_ the competition. The prize was a trip to ... the dinosaur museum!

3 Order the words to make questions. Answer.

1 on What holiday did do ? Elsa

What did Elsa do on holiday?

She went to museums.

2 ? museum kind of summer did they

What visit last

3 dinosaurs did live ? When

4 What watch Elsa did ?

5 discover What did ? Hendrickson Sue

6 points many teams did How have ? the

7 the Did answer the team know ? other

8 Elsa's win did team What ?

1 Read the story. Number these people in the order they appear.



a thief



Jake



Sam  1



the police



Rosie



Mrs Black

My name's Sam. Rosie is my neighbour. Last Saturday she went to the park. I went shopping with Mum, but later I went to the park to meet her.



We played tennis in the park with Rosie's brother Jake. Jake hit the ball over the wall into Mrs Black's garden. Mrs Black doesn't like children. She never gives them back their tennis balls.

We didn't want to see Mrs Black. So Rosie climbed over the wall and jumped into the garden. Then she saw a thief. She watched him. He opened a window and climbed into the house.



Rosie thought quickly. She called the police on her mobile phone. They arrived in a police car. They arrested the thief.

Mrs Black invited Rosie into the house. She said thank you to her and she gave her a drink and some biscuits. Then she gave Rosie her tennis ball – and a big bag of other tennis balls too!



2 Read again and answer the questions about Sam's story. Use notes.

	Sam's story	Your story
1 Who is the story about?	Sam, Rosie, Jack, Mrs Black, a thief	
2 When did it happen?		
3 Where did the character go?		
4 What did he/she do there?		
5 What happened?		
6 What did the character see?		
7 What did he/she do?		
8 What happened next?		
9 How did the story end?		

3 Write a story.

- 1 Plan your story. Answer some or all of the questions in activity 2.
- 2 Use your notes to write your story. Add some interesting information.
- 3 Check your story carefully.
- 4 Write out the corrected text and draw a picture.

1 Write. Use your dictionary. **D**

5 \_\_\_\_\_ 6 \_\_\_\_\_

1 \_\_\_\_\_ 7 \_\_\_\_\_

2 \_\_\_\_\_ 8 \_\_\_\_\_

3 *fork* \_\_\_\_\_ 9 \_\_\_\_\_

4 \_\_\_\_\_ 10 \_\_\_\_\_

2 Compare with activity 1. Write.

1 2 3

He needs a knife,  
a bowl, a cup and  
a jug.

3 Read. Write *True* or *False*. Then write three more true sentences. **D**

- 1 Plates are usually made of china. True
- 2 Knives are usually made of glass. \_\_\_\_\_
- 3 Glasses are made of wood. \_\_\_\_\_
- 4 Trays are sometimes made of plastic. \_\_\_\_\_
- 5 Forks are usually made of metal. \_\_\_\_\_
- 6 \_\_\_\_\_
- 7 \_\_\_\_\_
- 8 \_\_\_\_\_

**1 Match. Then write three sentences about your classes.**

- |                            |                                    |  |
|----------------------------|------------------------------------|--|
| 1 In Maths you have to     | <input checked="" type="radio"/> c | a learn different computer programmes. |
| 2 In Art you have to       | <input type="radio"/>              | b read maps.                           |
| 3 In PE you have to        | <input type="radio"/>              | c draw graphs.                         |
| 4 In Geography you have to | <input type="radio"/>              | d play volleyball.                     |
| 5 In History you have to   | <input type="radio"/>              | e do experiments.                      |
| 6 In ICT you have to       | <input type="radio"/>              | f make sculptures.                     |
| 7 In Science you have to   | <input type="radio"/>              | g learn about the Romans.              |



What do you do at school?

- 8 \_\_\_\_\_
- 9 \_\_\_\_\_
- 10 \_\_\_\_\_



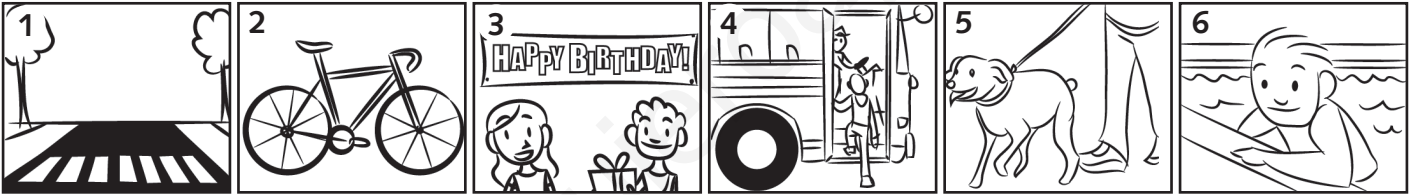

**2 Match. Then answer the questions for your country.**

Yes, you do. No, you don't. Yes, they do. No, they don't.



- |  |  |
|--|--|
| a Do you have to learn to swim? <input checked="" type="radio"/> 6 | d Do dogs have to have a lead? <input type="radio"/>                       |
| _____  | _____  |
| b Do you have to buy a ticket? <input type="radio"/>               | e Do cars have to stop? <input type="radio"/>                              |
| _____  | _____  |
| c Do you have to wear a helmet? <input type="radio"/>              | f Do you have to give a present at birthday parties? <input type="radio"/> |
| _____  | _____  |

**3 Order the words to make a question. Then answer for you.**

- |   |  |       |
|---|--|-------|
| 1  | every day a shower you Do have to have ?       | _____ |
|   | <i>Do you have to have a shower every day?</i> | _____ |
| 2  | Do your pet have to you feed ?                 | _____ |
|   | _____  | _____ |
| 3  | vegetables eat you have to Do ?                | _____ |
|   | _____  | _____ |
| 4  | Do plants you the water have to ?              | _____ |
|   | _____  | _____ |



1 Read the tourist guide. Circle the topics you read about.

hotels health sport culture food pets people school beaches transport

### Planet Travel Guide 3010

**Are you thinking of visiting VPZ59? Here are five top tips for visitors.**



**1** VPZ59 has got two suns and it's very hot. The sun's radiation is dangerous for Earthlings. All visitors from Earth have to use a special cream.



**2** VPZ59ers are very friendly, but you have to know what to do when you meet them. If you want to make friends, you have to learn how to say hello!



**3** You can find fantastic things to eat. VPZ59 is famous for its vipi fruits. They are big, blue and delicious. You have to try them!



**vipi fruit**

**4** It's easy to travel on VPZ59. There are transporter stations on every street. You have to buy a ticket. Then you stand in the transporter and say where you want to go. In 15 seconds, you're there!



**Transporter Station**

**5** You have to watch a VPZball match. There are two teams of 11 people. They play with a ball. They can't touch the ball with their hands. They have to put the ball in a net. It's strange, but it's fun!

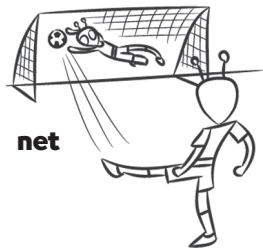

**net**

2 Look at the tourist guide again. Complete the notes.

Health - the sun is <sup>1</sup> hot - visitors have to use <sup>2</sup> \_\_\_\_\_.

People - VPZ59ers are <sup>3</sup> \_\_\_\_\_ - you have to know how to <sup>4</sup> \_\_\_\_\_.

Food - the food is <sup>5</sup> \_\_\_\_\_ - <sup>6</sup> \_\_\_\_\_ are big  
<sup>7</sup> \_\_\_\_\_, <sup>8</sup> \_\_\_\_\_.

Transport - easy - <sup>9</sup> \_\_\_\_\_ stations - <sup>10</sup> \_\_\_\_\_ a ticket -  
<sup>11</sup> \_\_\_\_\_ your destination.

Sport - VPZball - two teams of <sup>12</sup> \_\_\_\_\_ - can't touch the ball with their  
<sup>13</sup> \_\_\_\_\_, put the ball into a <sup>14</sup> \_\_\_\_\_.

3 Write a tourist guide for a planet. 

- 1 Imagine your planet. Write notes about some of these things:
  - health
  - pets
  - food
  - transport
  - sport
  - school
  - culture
  - beaches
  - hotels
  - good manners
- 2 Choose the five most interesting areas. Write your tips.
- 3 Check your work carefully.
- 4 Write your tourist guide. Draw some pictures.

1 Write. Use your dictionary. **D**

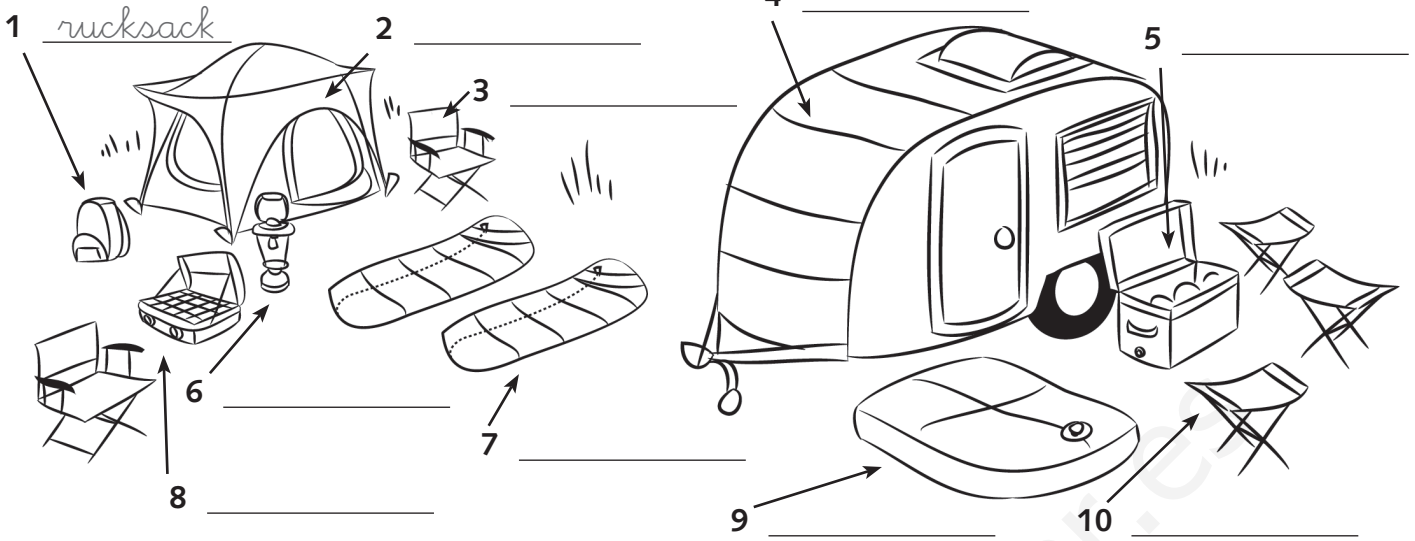

2 Look at activity 1. Write *True* or *False*. Correct the false sentences.

Look at the tent.

- 1 There are two sleeping bags. True
- 2 The rucksack is beside the tent. \_\_\_\_\_
- 3 There's a coolbox. \_\_\_\_\_
- 4 They've got two chairs. \_\_\_\_\_
- 5 They haven't got a lamp. \_\_\_\_\_
- 6 \_\_\_\_\_
- 7 \_\_\_\_\_

Look at the caravan.

- 8 The caravan is smaller than the tent. \_\_\_\_\_
- 9 They've got an airbed. \_\_\_\_\_
- 10 They've got a stove. \_\_\_\_\_
- 11 There are three stools. \_\_\_\_\_
- 12 They haven't got a lamp. \_\_\_\_\_
- 13 \_\_\_\_\_
- 14 \_\_\_\_\_

3 Complete the dialogues.

1

Camping list

- tent
- lamp
- sleeping bags
- rucksack

Have you got the lamp?  
 Yes, I have.

Have you got the tent?  
 \_\_\_\_\_

Have you got the sleeping bags?  
 \_\_\_\_\_

Have you got the rucksack?  
 \_\_\_\_\_

2

Camping list

- airbeds
- coolbox
- stools
- stove

\_\_\_\_\_?  
 \_\_\_\_\_?

Yes, I have.

\_\_\_\_\_?  
 \_\_\_\_\_?

No, I haven't.

\_\_\_\_\_?  
 \_\_\_\_\_?

Yes, I have.

\_\_\_\_\_?  
 \_\_\_\_\_?

No, I haven't.

1 Write two sentences for each picture. Use your dictionary. **D**

towel laptop ~~ticket~~ mobile phone

take a photo ✓ phone a friend ✗ write an e-mail ✗ ~~theatre~~ ✗  
go swimming ✓ have a shower ✗ watch a video ✓ ~~pop concert~~ ✓



1 He's got a ticket. He isn't going to the theatre, he's going to a pop concert.



2 \_\_\_\_\_  
\_\_\_\_\_  
\_\_\_\_\_



3 \_\_\_\_\_  
\_\_\_\_\_  
\_\_\_\_\_



4 \_\_\_\_\_  
\_\_\_\_\_  
\_\_\_\_\_

2 Write the questions. Match and write the complete answer.

1 are Where going you to ? tomorrow go  
Where are you going to go tomorrow?

a Sam

2 ? go are going to How you

b some jeans

3 to are Who you meet ? going

c by bus

4 going What you ? buy to are

d at a café

5 have lunch to ? are Where you going

e to the shopping centre

6 time are you What to leave ? going

I'm going to go to the shopping centre.

f eight o'clock

**1 Read the article. Answer the questions.**

- 1 What did Eva win?
- 2 Where does Eva find her ideas?
- 3 Where is Eva going to go?



*Oxford Voice:* Eva, when did you start making videos?

*Eva:* I started about three years ago. My mobile phone has a video camera and I started making mini films with it.

*Oxford Voice:* How do you think of an idea for a film?

*Eva:* Well, I often find ideas in newspapers. Then I talk to my friends and we invent the story together.

*Oxford Voice:* Were you surprised to win the award?

## The winner is ... Eva Taylor!

The **Oxford Voice** interviewed Eva Taylor, the winner of this year's **Student Video** competition. The award is for the best video made by students. Eva and her team made a short film of a detective story. They wrote the story and planned the film. They used their friends as actors and they made the film at their homes and in their gardens. The famous actor **Christine Moore** said, 'Eva worked very hard and the film is fantastic!'

*Eva:* Yes, I was – very! And now I'm very excited.

*Oxford Voice:* Why?

*Eva:* Because the prize is a trip to Hollywood for me and the team. We're going to go in a jumbo jet – first class! Then we're going to visit the most important studios. We're going to watch a film by my favourite director, Billy Benson. I think he's amazing.

*Oxford Voice:* That's great. Congratulations, and have a good time!

**2 Read the article again. Answer the questions with notes.**

	The <i>Oxford Voice</i> article	Your article
1 What is the award for?	Student video competition	
2 Who won the award and why?		
3 How does the award winner feel?		
4 What is the prize?		
5 What plans does the award winner have?		

**3 Write an article about an award.** 

- 1 Invent the name of your newspaper.
- 2 Complete the column in activity 2 for your award.
- 3 Write your article. Include some other interesting information.
- 4 Correct your article.
- 5 Write out the corrected text and draw a picture.

1 Complete the questions and answers. Write the names.

- What's Harry doing? He's planting seeds.
- What are Bella and David doing? They're watering the flowers.
- Ed doing? making a window box.
- Frank and Glen doing? eating carrots.
- Isa and Jo doing? digging a hole.
- Ann doing? cutting the grass.

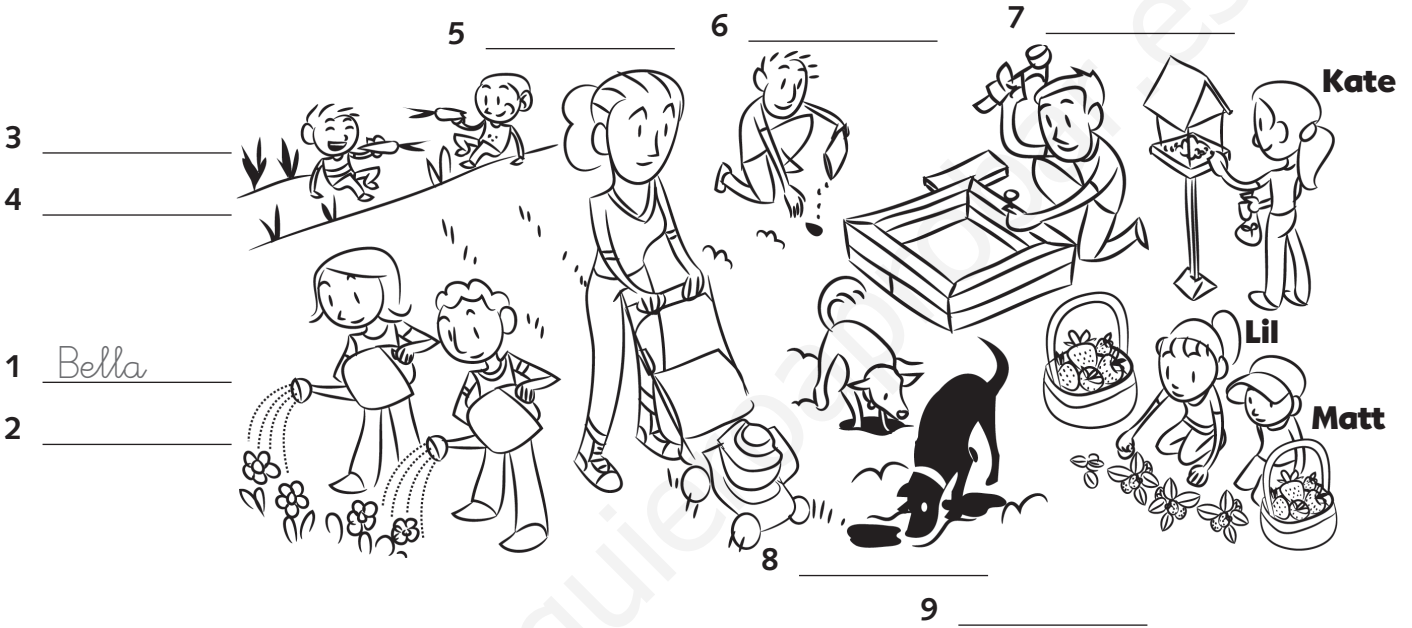

2 Look at activity 1 again. Answer the questions. Then write two more questions.

No, she isn't. Yes, she is. Yes, he is. ~~No, he isn't.~~  
 Yes, they are. No, they aren't. Yes, they are. No, they aren't.

- 1 Is Ed watering the flowers? No, he isn't.
  - 2 Is Kate picking strawberries? \_\_\_\_\_
  - 3 Is Harry planting seeds? \_\_\_\_\_
  - 4 Is Ann cutting the grass? \_\_\_\_\_
  - 5 Are Isa and Jo digging a hole? \_\_\_\_\_
  - 6 Are Frank and Glen eating carrots? \_\_\_\_\_
  - 7 Are Bella and David making a window box? \_\_\_\_\_
  - 8 Are Lil and Matt feeding the birds? \_\_\_\_\_
  - 9 \_\_\_\_\_
  - 10 \_\_\_\_\_
- Yes, she is.
- Yes, they are.



1 Complete.

shop assistant ~~security guard~~ taxi driver musician nurse cleaner She's a He's a

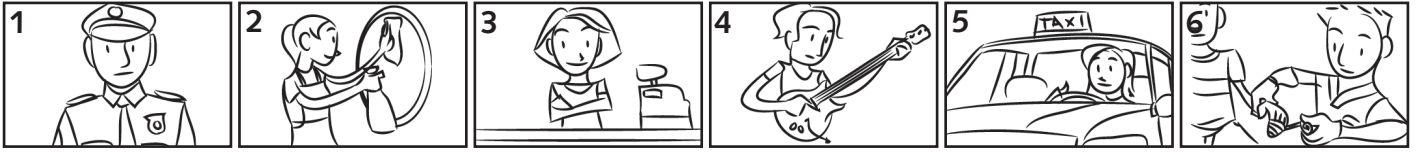

He's a security guard.      She's a \_\_\_\_\_  
 She's a \_\_\_\_\_  
 He's a \_\_\_\_\_

2 Write the sentences. Then look at the pictures and match.

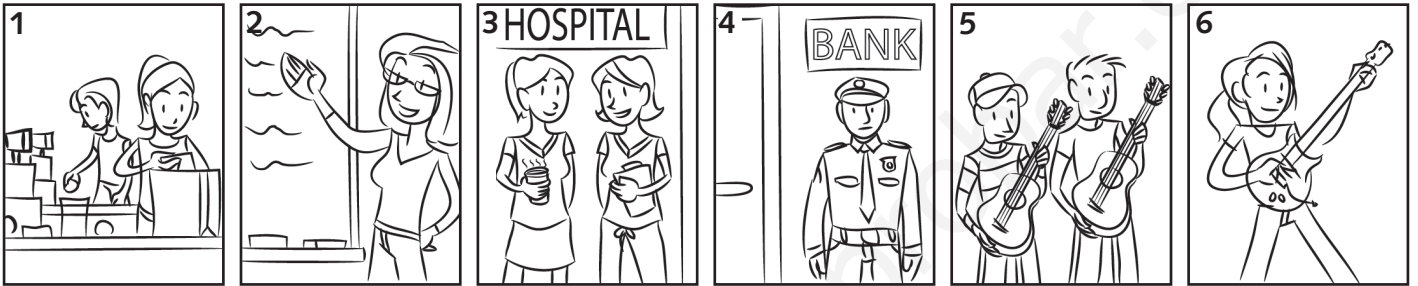

a works at She a school .      d They . uniform a wear  
She works at a school.        
 b at a . supermarket They work      e uniform wears He a .  
 \_\_\_\_\_        
 c the guitar play . They      f guitar . plays She the  
 \_\_\_\_\_     

3 Complete.

tennis ~~on Park Road~~ at half past eight at nine o'clock on Station Road badminton



1 Where does he live?  
 He lives on Park Road.  
 2 What time does he start school?  
 He \_\_\_\_\_  
 \_\_\_\_\_  
 3 What sport does he play?  
 He \_\_\_\_\_



4 Where do they live?  
 They live \_\_\_\_\_  
 5 What time do they start school?  
 They \_\_\_\_\_  
 \_\_\_\_\_  
 6 What sport do they play?  
 They \_\_\_\_\_

**1** Write the verbs and the Past Simple forms.

~~go~~ drink listen to live eat have listened to had lived ate ~~went~~ drank



go to school  
went to school



\_\_\_\_\_ in a house  
\_\_\_\_\_ in a house



\_\_\_\_\_ rock 'n' roll  
\_\_\_\_\_ rock 'n' roll



\_\_\_\_\_ a hamburger  
\_\_\_\_\_ a hamburger



\_\_\_\_\_ a milkshake  
\_\_\_\_\_ a milkshake



\_\_\_\_\_ a mobile phone  
\_\_\_\_\_ a mobile phone

**2** Look and number the sentences.

My granny's life was different from mine in some ways.



- a She didn't live in a big house.
- b She didn't eat hamburgers.
- c She didn't play computer games.  1
- d She didn't have an MP3 player.
- e She went to school.
- f She listened to rock 'n' roll.

**3** Write.

My grandad's life was different from mine in some ways.

milk ~~computer~~ to the cinema pizza



He didn't have a  
computer.

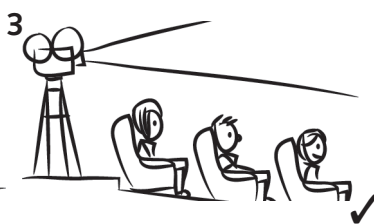

1 Match the verbs and their Past Simple forms.

go eat buy write make visit see wear have meet drink play

wrote went ate visited saw made wore bought played drank met had

2 Read and write *True* or *False*.

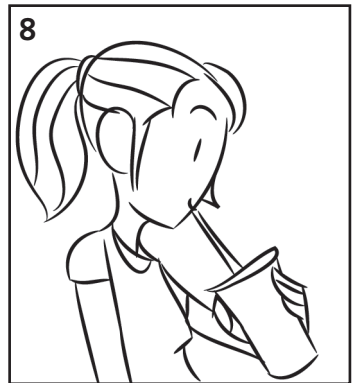
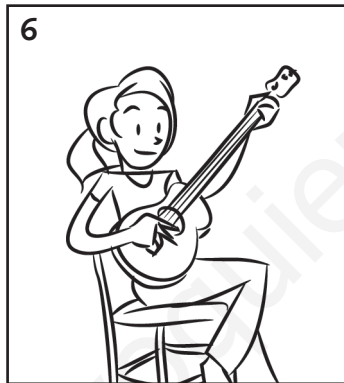
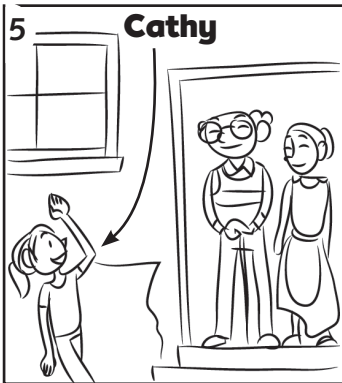
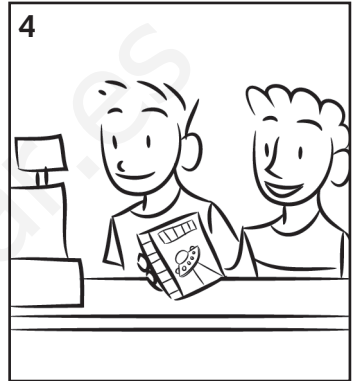
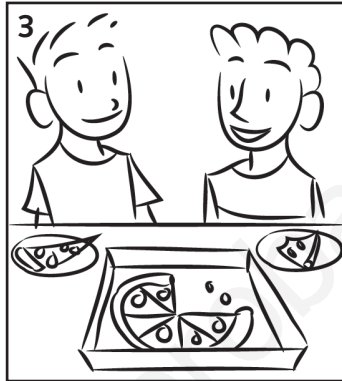

1 Jack went on a bus. True

2 Jack met a friend. \_\_\_\_\_

3 Jack and Dave ate hamburgers. \_\_\_\_\_

4 Jack and Dave bought a T-shirt. \_\_\_\_\_

5 Cathy visited her friend. \_\_\_\_\_

6 Cathy played the piano. \_\_\_\_\_

7 Cathy made a pizza with her granny. \_\_\_\_\_

8 Cathy drank a milkshake. \_\_\_\_\_

3 Look again. Match the questions and answers. Complete.

1 What did Cathy play?

b

a They ate a pizza.

2 What did Jack and Dave eat?

b She \_\_\_\_\_ the guitar.

3 Who did Cathy visit?

c They \_\_\_\_\_ a computer game.

4 What did Jack and Dave buy?

d She \_\_\_\_\_ her grandparents.

5 What did Cathy make?

e He \_\_\_\_\_ on a bus.

6 What did Jack do?

f She \_\_\_\_\_ a pizza.

**1 Complete.**

cheese lemons lemonade pizza sugar ~~tomatoes~~ onions water

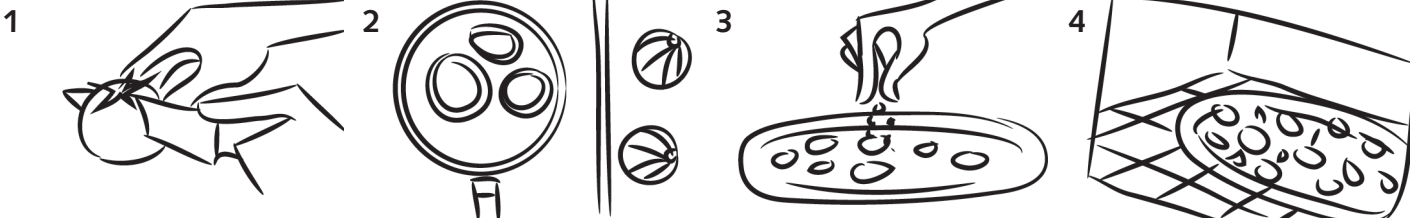

1 chop the tomatoes fry the \_\_\_\_\_ add the \_\_\_\_\_ bake the \_\_\_\_\_

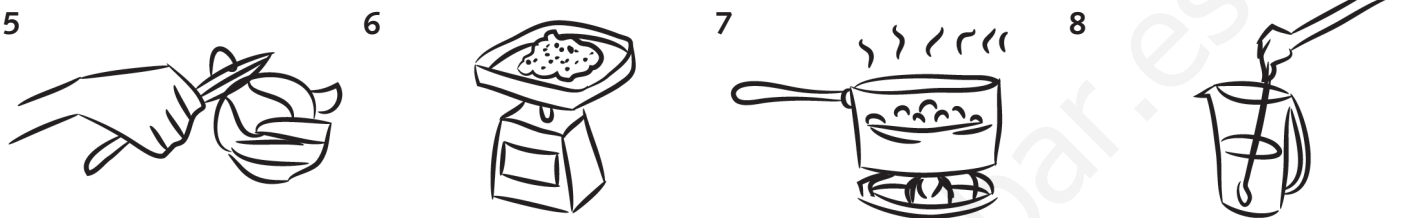

5 peel the \_\_\_\_\_ weigh the \_\_\_\_\_ boil the \_\_\_\_\_ mix the \_\_\_\_\_

**2 Complete the recipe.**

peel add ~~wash~~ add chop mix

**How to make a fruit sundae**

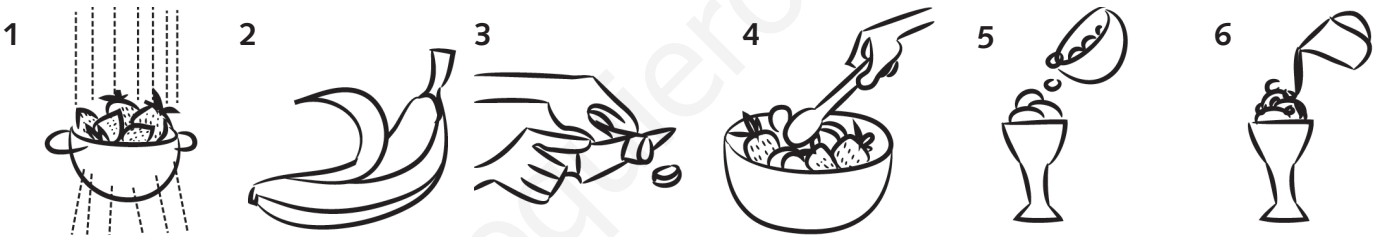

1 First you have to wash the strawberries.  
 2 Then you have to \_\_\_\_\_ the banana.  
 3 Then you have to \_\_\_\_\_ the banana.  
 4 Then you have to \_\_\_\_\_ the fruit.  
 5 Then you have to \_\_\_\_\_ the fruit to the ice cream.  
 6 Then you have to \_\_\_\_\_ the chocolate.

**3 Answer the questions about the recipe.**

- 1 Do I have to chop the strawberries?
- 2 Do I have to wash the strawberries?
- 3 Do I have to peel the banana?
- 4 Do I have to fry the banana?
- 5 Do I have to mix the fruit?
- 6 Do I have to add sugar?
- 7 Do I have to weigh the chocolate?
- 8 Do I have to bake the fruit sundae?

No, you don't.  
Yes, you do.  
 \_\_\_\_\_  
 \_\_\_\_\_  
 \_\_\_\_\_  
 \_\_\_\_\_  
 \_\_\_\_\_

1 Write.

path ~~cliff~~ lake rock waterfall cave island wood

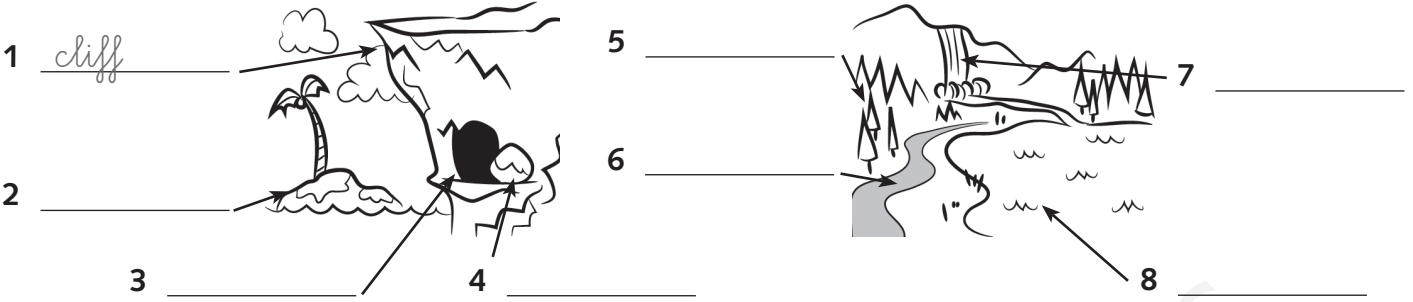

2 Complete.

a rock ~~to the waterfall~~ in a lake a cliff a hill in a wood ~~to the island~~  
in a river on a path ~~a tree~~

- 1 swim to the island \_\_\_\_\_
- 2 climb \_\_\_\_\_ the tree \_\_\_\_\_
- 3 walk \_\_\_\_\_ to the waterfall \_\_\_\_\_

3 Write.



He's going to climb a hill.

He isn't going to climb a hill.

He's going to climb a cliff.



She's going to swim in a river.

\_\_\_\_\_

\_\_\_\_\_



He's going to walk on the island.

\_\_\_\_\_

\_\_\_\_\_



She's going to run to the cave.

\_\_\_\_\_

\_\_\_\_\_







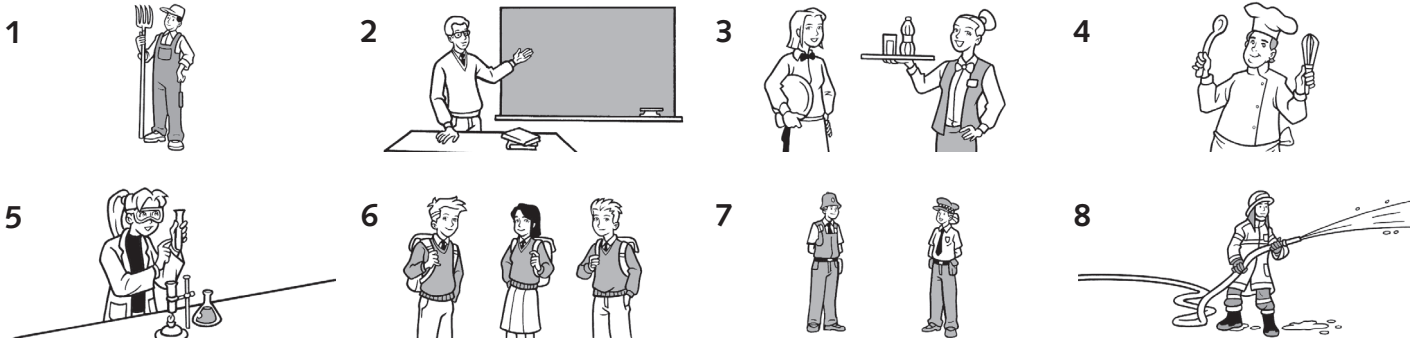



**1** Look and number the sentences. **D**

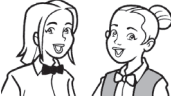

- a He's a cook.  4
- b They're waitresses.
- c He's a firefighter.
- d They're students.
- e He's a farmer.
- f They're police officers.
- g He's a teacher.
- h She's a scientist.

**2** Look and answer. Then write three more questions.

No, he isn't. No, they aren't. ~~Yes, he is.~~

<p>1  Is he a farmer? <u>Yes, he is.</u></p>	<p>4  _____ No, she isn't.</p>
<p>2  Are they teachers? _____</p>	<p>5  _____ Yes, they are.</p>
<p>3  Is he a firefighter? _____</p>	<p>6  _____ No, they aren't.</p>

**3** Look and read the blog posts. Complete the dialogues with *Yes, I am* or *No, I'm not*.

1  Hi, Ben. Are you from England?

Yes, I am.

Are you 11?

\_\_\_\_\_

Are you in class 6A?

\_\_\_\_\_

**My name's Ben. I'm from England. I'm 12. I'm in class 6A.**

2  Hi, Lisa. Are you from the USA?

\_\_\_\_\_

Are you 11?

\_\_\_\_\_

Are you in class 6A?

\_\_\_\_\_

**My name's Lisa. I'm from the USA. I'm 11. I'm in class 6B.**

**Finished?** Write three questions and ask a friend.



1 Write. **D** new fast ~~tall~~ small short young old big slow old

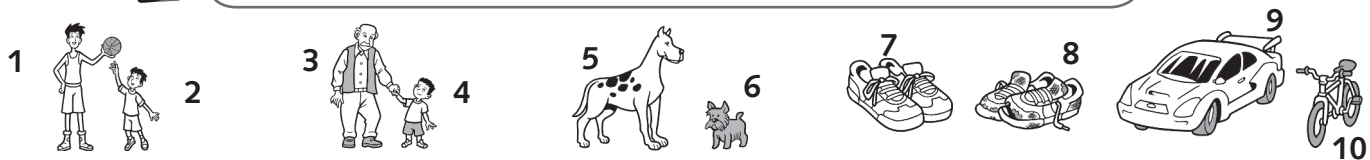

1 tall      3 \_\_\_\_\_      5 \_\_\_\_\_      7 \_\_\_\_\_      9 \_\_\_\_\_  
 2 \_\_\_\_\_      4 \_\_\_\_\_      6 \_\_\_\_\_      8 \_\_\_\_\_      10 \_\_\_\_\_

2 Label the picture. **D** aunt ~~mother~~ brother cousins sister uncle father

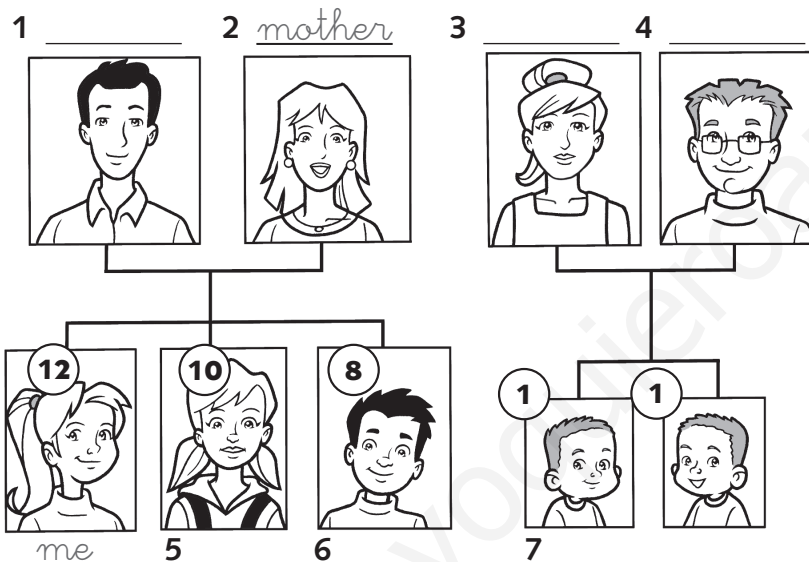
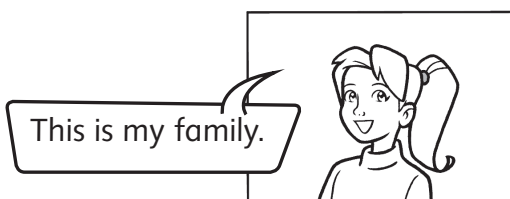

3 Look at Activity 2. Read and write **True** or **False**. Then write four more true sentences.

- 1 My father is taller than my mother. True
- 2 I am older than my brother and sister. \_\_\_\_\_
- 3 My sister is younger than my cousins. \_\_\_\_\_
- 4 My uncle is shorter than my aunt. \_\_\_\_\_
- 5 \_\_\_\_\_
- 6 \_\_\_\_\_
- 7 \_\_\_\_\_
- 8 \_\_\_\_\_

4 Answer the questions. Then write three more questions.

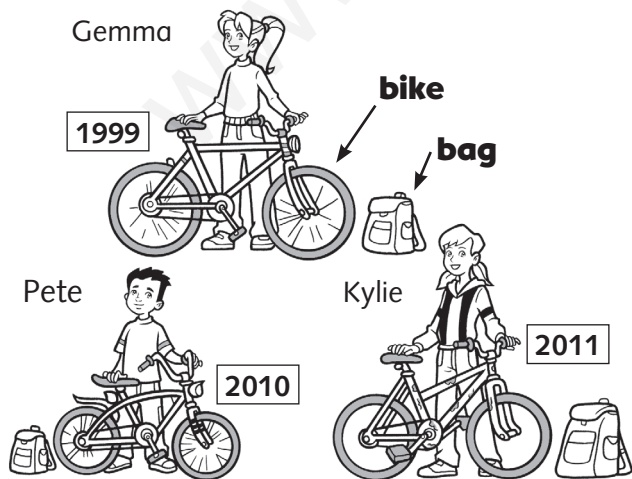

- 1 Who's got the newest bike? Kylie
- 2 Who's got the smallest bag? \_\_\_\_\_
- 3 Who's got the biggest bike? \_\_\_\_\_
- 4 \_\_\_\_\_ ? Pete
- 5 \_\_\_\_\_ ? Gemma
- 6 \_\_\_\_\_ ? Kylie

**Finished?** Write about your family and friends.



1 Write. **D**

bedroom garage ~~garden~~ kitchen living room bathroom

bed table sofa ~~plants~~ posters chair cupboard bike balls toys

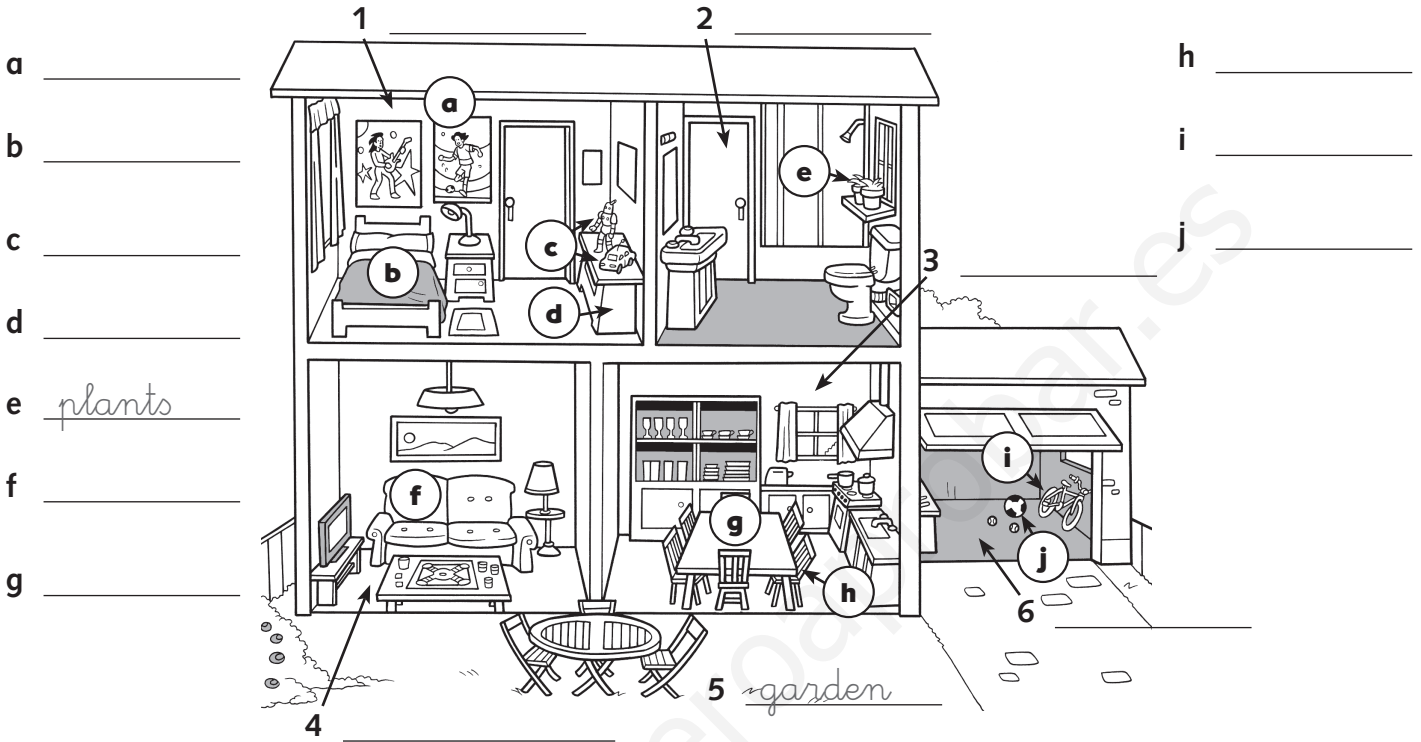

2 Read and write **True or False**.

- 1 There are some plants in the bathroom. True
- 2 There isn't a table in the kitchen. \_\_\_\_\_
- 3 There's a table in the garage. \_\_\_\_\_
- 4 There are some bikes in the living room. \_\_\_\_\_
- 5 There isn't a sofa in the garage. \_\_\_\_\_
- 6 There aren't any balls in the garden. \_\_\_\_\_

3 Answer the questions. Then write two more questions.

~~Yes, there is.~~ Yes, there is. Yes, there are. No, there aren't.

- 1 Is there a sofa in the living room? Yes, there is.
- 2 Are there any toys in the garden? \_\_\_\_\_
- 3 Is there a table in the garden? \_\_\_\_\_
- 4 Are there any chairs in the kitchen? \_\_\_\_\_
- 5 \_\_\_\_\_ Yes, there are.
- 6 \_\_\_\_\_ No, there isn't.

**Finished?** Write some sentences about your home.



**1** Complete the dialogues. **D**

doing homework   helping Mum   eating ice cream   ~~cooking~~   watching television  
 playing a computer game



What are you doing?

I'm cooking.



What are you doing?

\_\_\_\_\_

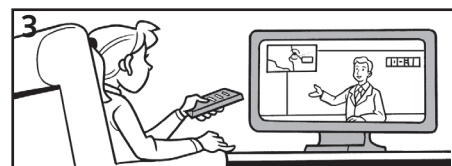

What \_\_\_\_\_ doing?

\_\_\_\_\_



What \_\_\_\_\_

\_\_\_\_\_

\_\_\_\_\_



\_\_\_\_\_

\_\_\_\_\_

\_\_\_\_\_



\_\_\_\_\_

\_\_\_\_\_

\_\_\_\_\_

**2** Write. **D**

~~playing football~~   running   riding a bike   drinking some water   eating ice cream  
 sleeping   taking a photo   swimming

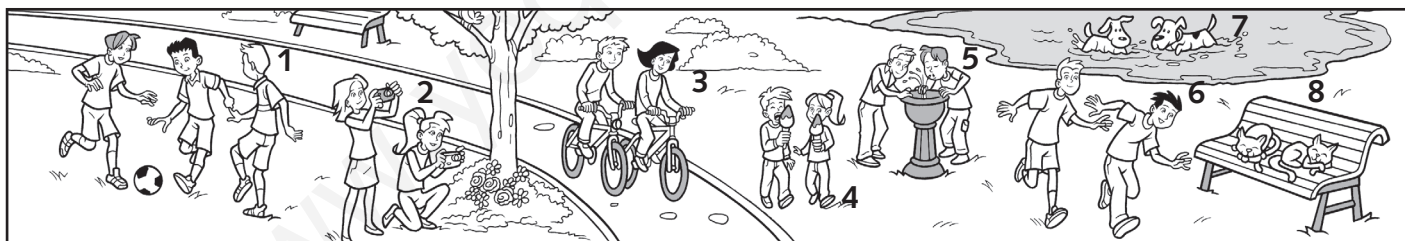

1 They're playing football.

2 \_\_\_\_\_

3 \_\_\_\_\_

4 \_\_\_\_\_

5 \_\_\_\_\_

6 \_\_\_\_\_

7 \_\_\_\_\_

8 \_\_\_\_\_

**3** Answer the questions for you. Use *Yes, I am* or *No, I'm not*.

1 Are you learning English? \_\_\_\_\_

3 Are you playing football? \_\_\_\_\_

2 Are you writing? \_\_\_\_\_

4 Are you doing your homework? \_\_\_\_\_

**Finished?** Draw two more activities. Write the dialogues.



1 Write. **D** scarf skirt jeans jacket ~~hat~~ glasses T-shirt shoes

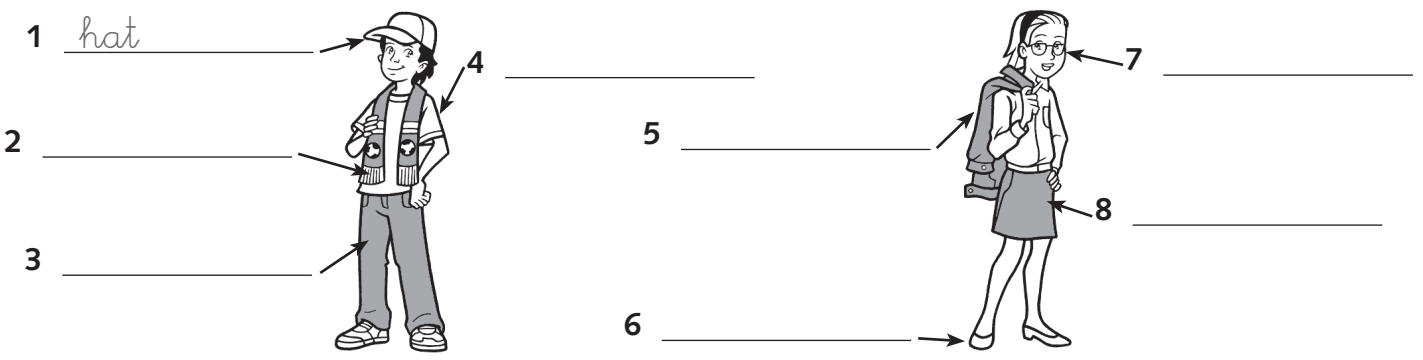

2 Look and answer. Then write two more questions.

Yes, he is. No, he isn't. Yes, she is. No, she isn't.

- 1 Is he wearing a scarf? Yes, he is.
- 2 Is she wearing trousers? \_\_\_\_\_
- 3 Is he wearing shoes? \_\_\_\_\_
- 4 Is she wearing a T-shirt? \_\_\_\_\_
- 5 Is he wearing a jacket? \_\_\_\_\_
- 6 Is she wearing a hat? \_\_\_\_\_
- 7 \_\_\_\_\_ No, he isn't.
- 8 \_\_\_\_\_ Yes, she is.

3 Read and number. Then write one more sentence.

reading a book writing drawing ~~talking to the teacher~~  
listening to music making a model

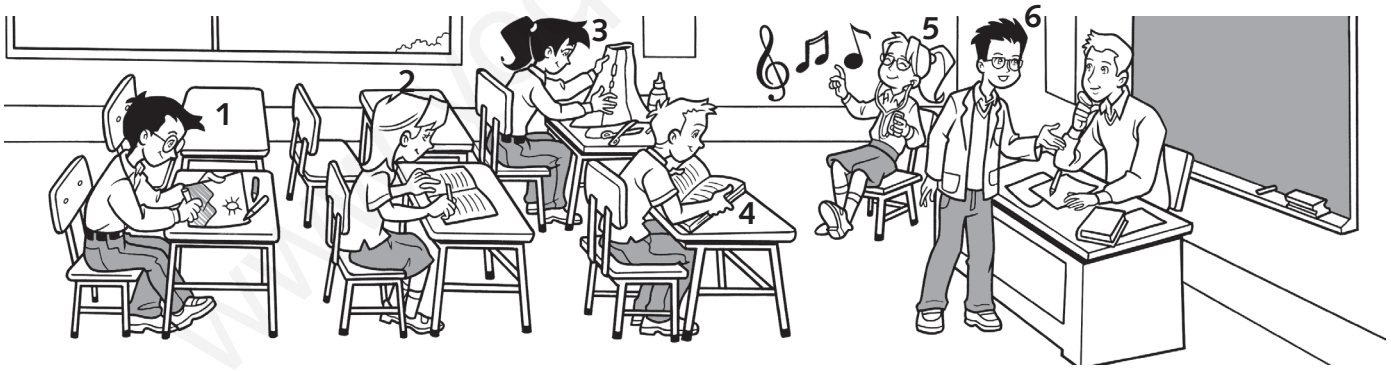

- a He's wearing trousers and a jacket. **6** He's talking to the teacher.
- b She isn't wearing a skirt. She's wearing trousers.  \_\_\_\_\_
- c She isn't wearing trousers. She's wearing glasses.  \_\_\_\_\_
- d He's wearing a T-shirt. He isn't wearing glasses.  \_\_\_\_\_
- e He isn't wearing a jacket. He's wearing glasses.  \_\_\_\_\_
- f She's wearing a skirt and a T-shirt. She isn't wearing glasses.  \_\_\_\_\_

**Finished?** Look at your friends. What are they wearing?





**1 Write the days of the week and the activities. D**

play basketball   have a guitar class   watch television  
do karate   ~~go swimming~~   go to the shops   do homework

<b>Tom's activities</b> 	<b>1</b>	<b>2</b>	<b>3</b>
	M <u>onday</u> <u>go swimming</u>	T _____ _____ _____	W _____ _____ _____
<b>4</b>	<b>5</b>	<b>6</b>	<b>7</b>
T _____ _____ _____	F _____ _____ _____	S _____ _____ _____	S _____ _____ _____

**2 Look at Tom's activities. Read and write True or False.**



- |   |  |
|---|--|
| 1 I go swimming on Monday. <u>True</u>      | 5 I watch TV on Thursday. _____        |
| 2 I don't go shopping on Tuesday. _____     | 6 I don't do homework on Friday. _____ |
| 3 I have a guitar class on Wednesday. _____ | 7 I go shopping on Saturday. _____     |
| 4 I play basketball on Wednesday. _____     | 8 I do karate on Sunday. _____         |

**3 Answer the questions for you. Use Yes, I do and No, I don't.**

- Do you play basketball on Wednesday? \_\_\_\_\_
- Do you go to the shops on Saturday? \_\_\_\_\_
- Do you do your homework on Sunday? \_\_\_\_\_
- Do you have a guitar class on Monday? \_\_\_\_\_
- Do you go swimming on Tuesday? \_\_\_\_\_
- Do you watch television on Thursday? \_\_\_\_\_

**4 Complete for you. Use affirmative and negative sentences.**

- |                            |                      |
|----------------------------|----------------------|
| 1 I don't _____ on Monday. | 4 _____ on Thursday. |
| 2 I _____ on Tuesday.      | 5 _____ on Friday.   |
| 3 _____ on Wednesday.      | 6 _____ on Saturday. |

**Finished?** Write the names of the months. Use a dictionary. What do you do each month?



1 Write. **D**

milk fish lemons ice cream onions cheese tomatoes  
sugar ~~bananas~~ flour eggs popcorn

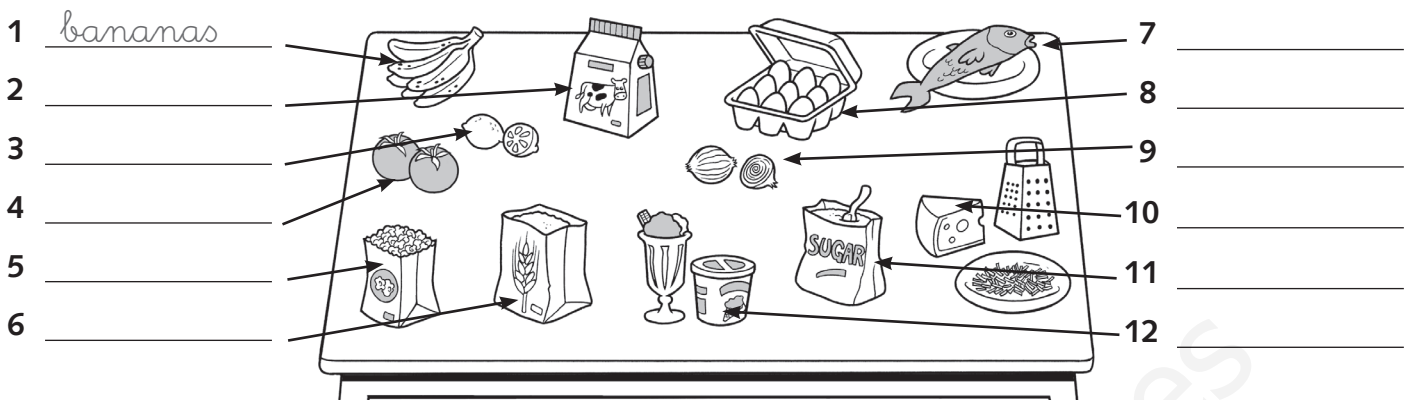

2 Read and write the names. Then write two more true sentences.

Al						
Pete						
Carla						
Flo						

- 1 He likes bananas. He doesn't like tomatoes. Al
- 2 She likes popcorn. She doesn't like milk. \_\_\_\_\_
- 3 She likes milk. She doesn't like fish. \_\_\_\_\_
- 4 He likes bananas. He doesn't like eggs. \_\_\_\_\_
- 5 \_\_\_\_\_
- 6 \_\_\_\_\_

3 Answer. Then write four questions.

Yes, she does. No, she doesn't. ~~Yes, he does.~~ No, he doesn't.









- 1 Does Al like milk? Yes, he does. 5 \_\_\_\_\_ Yes, he does.
- 2 Does Pete like eggs? \_\_\_\_\_ 6 \_\_\_\_\_ No, he doesn't.
- 3 Does Carla like fish? \_\_\_\_\_ 7 \_\_\_\_\_ No, she doesn't.
- 4 Does Flo like bananas? \_\_\_\_\_ 8 \_\_\_\_\_ Yes, she does.

**Finished?** What do people in your family like? What don't they like?



**1 Write. D** What do you do? Complete the last column.

do karate play badminton go swimming do ballet play tennis go rollerblading









	 Ann	 Bob	 Ed Di	You
1  <u>play badminton</u>	✓	X	✓	
2  _____	X	✓	X	
3  _____	✓	✓	✓	
4  _____	X	✓	X	
5  _____	✓	X	✓	
6  _____	X	✓	X	

**2 Answer.**

Yes, I do / he does / she does / they do.  
No, I don't / he doesn't / she doesn't / they don't.

- 1 Does Ann go swimming? Yes, she does.
- 2 Does Ann do ballet? \_\_\_\_\_
- 3 Does Bob play badminton? \_\_\_\_\_
- 4 Does Bob go rollerblading? \_\_\_\_\_
- 5 Do Ed and Di play tennis? \_\_\_\_\_
- 6 Do Ed and Di do karate? \_\_\_\_\_
- 7 Do you go swimming? \_\_\_\_\_
- 8 Do you do ballet? \_\_\_\_\_

**3 Look at activity 1 again. Write.**

- 1  She plays badminton.
- 2  She doesn't \_\_\_\_\_
- 3  He \_\_\_\_\_
- 4  \_\_\_\_\_
- 5  They \_\_\_\_\_
- 6  \_\_\_\_\_
- 7  I \_\_\_\_\_
- 8  I \_\_\_\_\_

**Finished?** Make a list of some more sports. Which sports do you do?



1 Write. **D**

bus station cinema sports centre supermarket library swimming pool



library

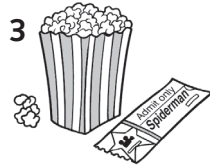

2 Read and write the names. Then write two more true sentences.

Ben	✓	X	✓	X	✓	X
Jon	X	✓	✓	X	X	✓
Tim	X	X	✓	X	✓	✓

1 He was at the library. Ben

4 They were at the cinema. \_\_\_\_\_

2 They were at the swimming pool.  
\_\_\_\_\_

5 \_\_\_\_\_ Jon

3 He wasn't at the sports centre. \_\_\_\_\_

6 \_\_\_\_\_ Ben Tim

3 Answer.

Yes, they were. ~~Yes, he was.~~ No, they weren't.  
No, they weren't. Yes, he was. No, he wasn't.

1 Was Ben at the library?

Yes, he was.

4 Were Ben and Tim at the supermarket?

\_\_\_\_\_

2 Was Jon at the sports centre?

\_\_\_\_\_

5 Were Jon and Tim at the bus station?

\_\_\_\_\_

3 Was Tim at the swimming pool?

\_\_\_\_\_

6 Were Jon and Tim at the library?

\_\_\_\_\_

4 Now answer for you. Yes, I was. No, I wasn't.

1 Were you at school yesterday? \_\_\_\_\_

2 Were you at the cinema yesterday? \_\_\_\_\_

3 Were you at the library yesterday? \_\_\_\_\_

4 Were you at the swimming pool yesterday? \_\_\_\_\_

5 Were you at the shopping centre yesterday? \_\_\_\_\_

6 Were you at the bus station yesterday? \_\_\_\_\_

**Finished?** Where were you last week? Write sentences.



**1** Complete the table.

watch have play

saw visited went

Infinitive	Past form	Infinitive	Past form	Infinitive	Past form
visit		go		see	
	played		watched		had

**2** Write.

to the cinema ~~a pop star~~ ~~breakfast~~ lunch ~~to school~~ volleyball  
~~grandparents~~ ~~a film~~ ~~tennis~~ an actor a football match a friend

- 1 visit grandparents  
 2 go to school  
 3 see a pop star  
 4 play tennis  
 5 have breakfast  
 6 watch a film

**3** Complete with names.

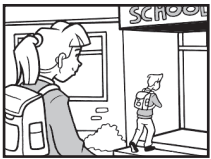

Alison



Bob



Clare

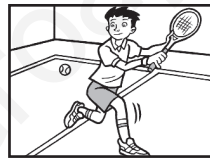

Dave



Ella



Fred

- 1 Ella watched a football match.  
 2 \_\_\_\_\_ had lunch at one o'clock.  
 3 \_\_\_\_\_ played tennis.  
 4 \_\_\_\_\_ went to school yesterday.  
 5 \_\_\_\_\_ visited his grandparents.  
 6 \_\_\_\_\_ saw a pop star.

**4** Write about Hannah's weekend.



1 She went to the  
cinema.



2 \_\_\_\_\_

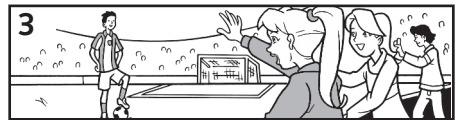

3 \_\_\_\_\_

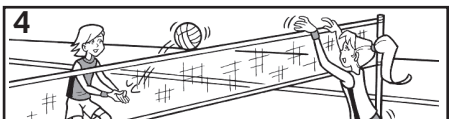

4 \_\_\_\_\_



5 \_\_\_\_\_



6 \_\_\_\_\_

**Finished?** Write about last weekend.