

Contents

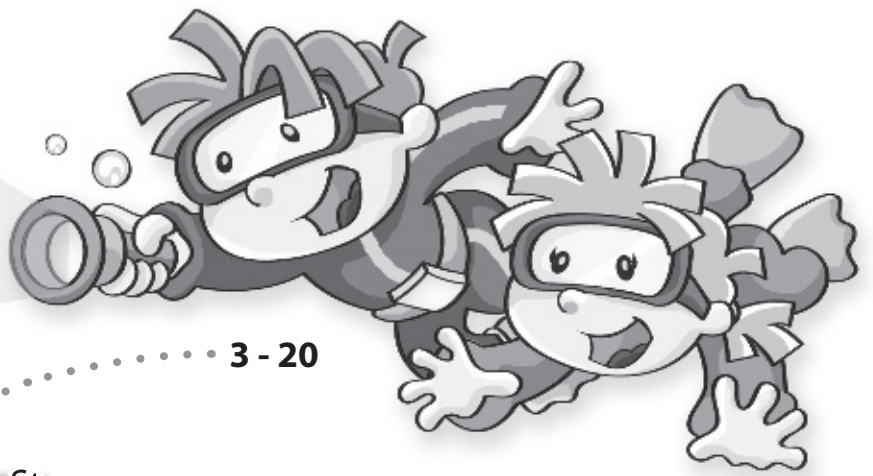

1	Celebrations	3 - 20
2	DVD	
	Animated Story	21 - 26
	Real Kids	27 - 40
3	Richmond Primary Reader	41 - 46
4	Reading Worksheets	47 - 58
5	Review Games	59 - 66
6	Tests	67 - 102
7	Values	103 - 134
8	Vocabulary Lists	135 - 140
9	Young Learner and Trinity Exams	141 - 144





Celebrations



* Halloween:

A Cart.	4
A Jack-o'-lantern	6

* Thanksgiving:

A Turkey	8
--------------------	---

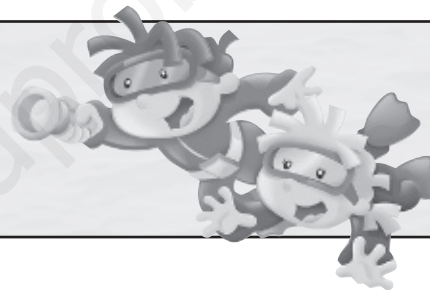

* Christmas:

A Christmas tree	12
----------------------------	----

* Easter:

Easter eggs	15
-----------------------	----



* Mother's Day:

A Rose	18
------------------	----





Halloween 1

A Cart 1   

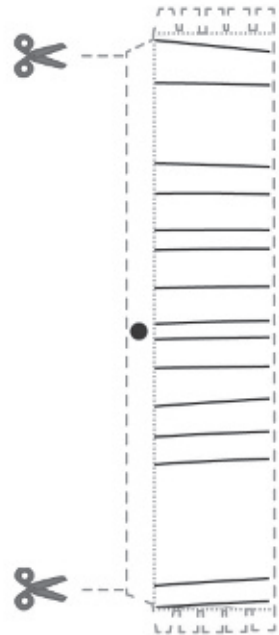
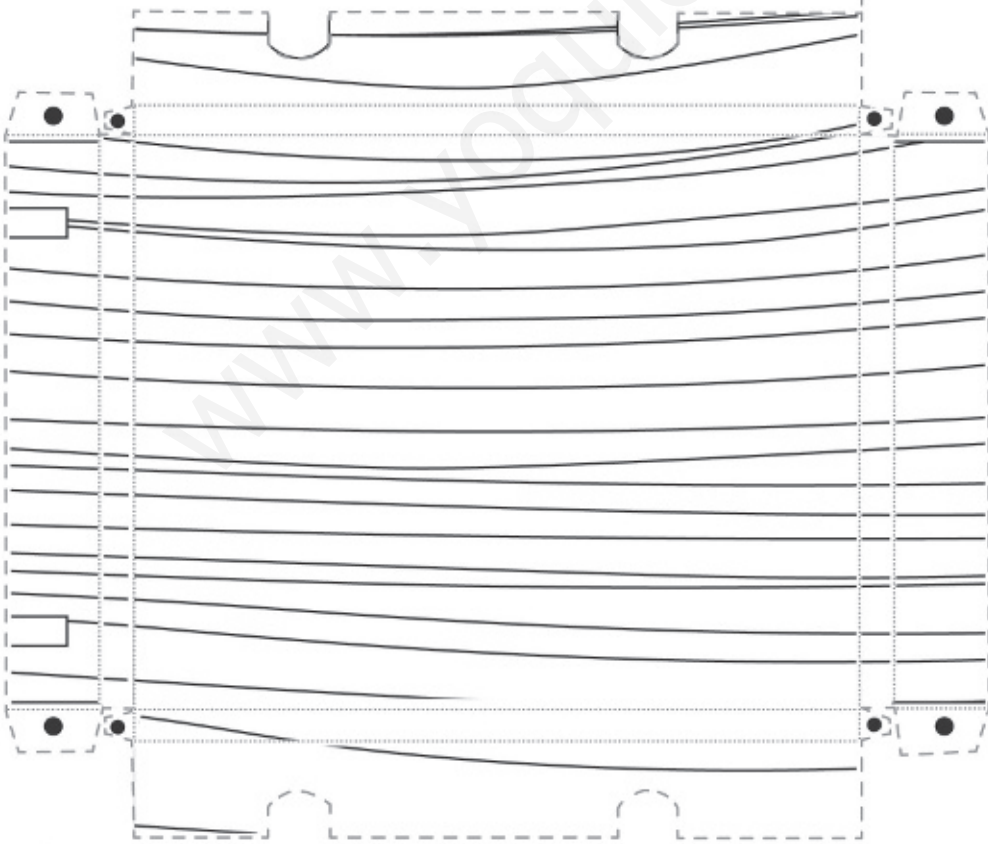
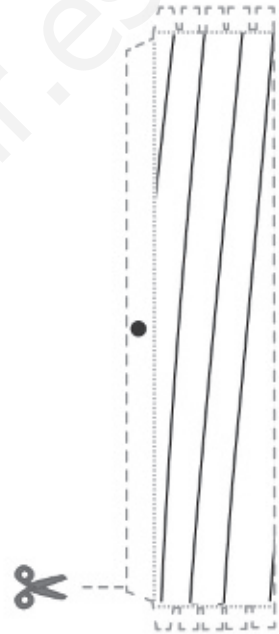
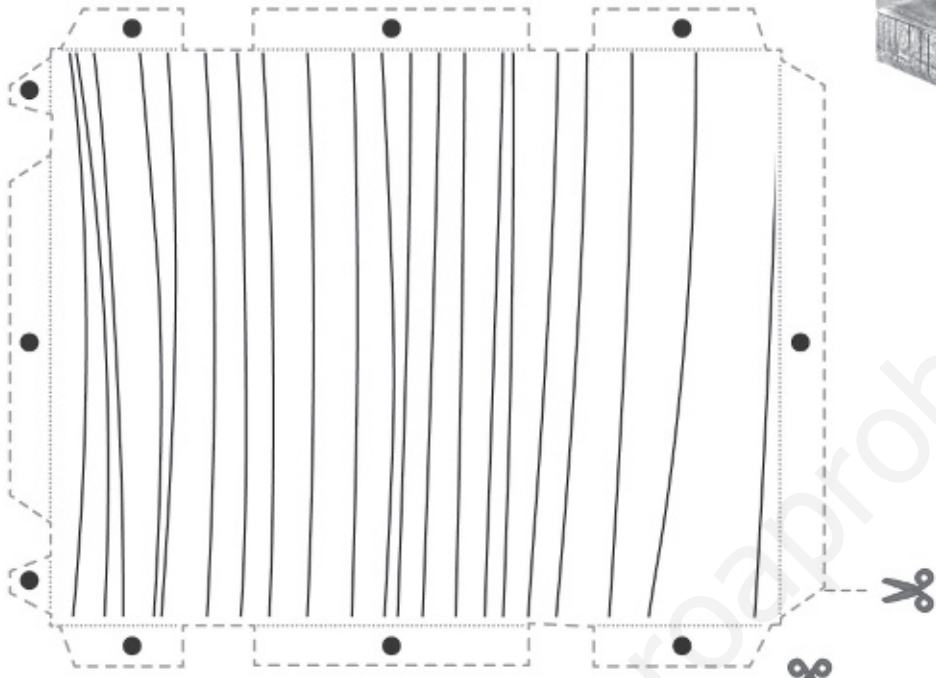



Halloween 2

A Cart 2   

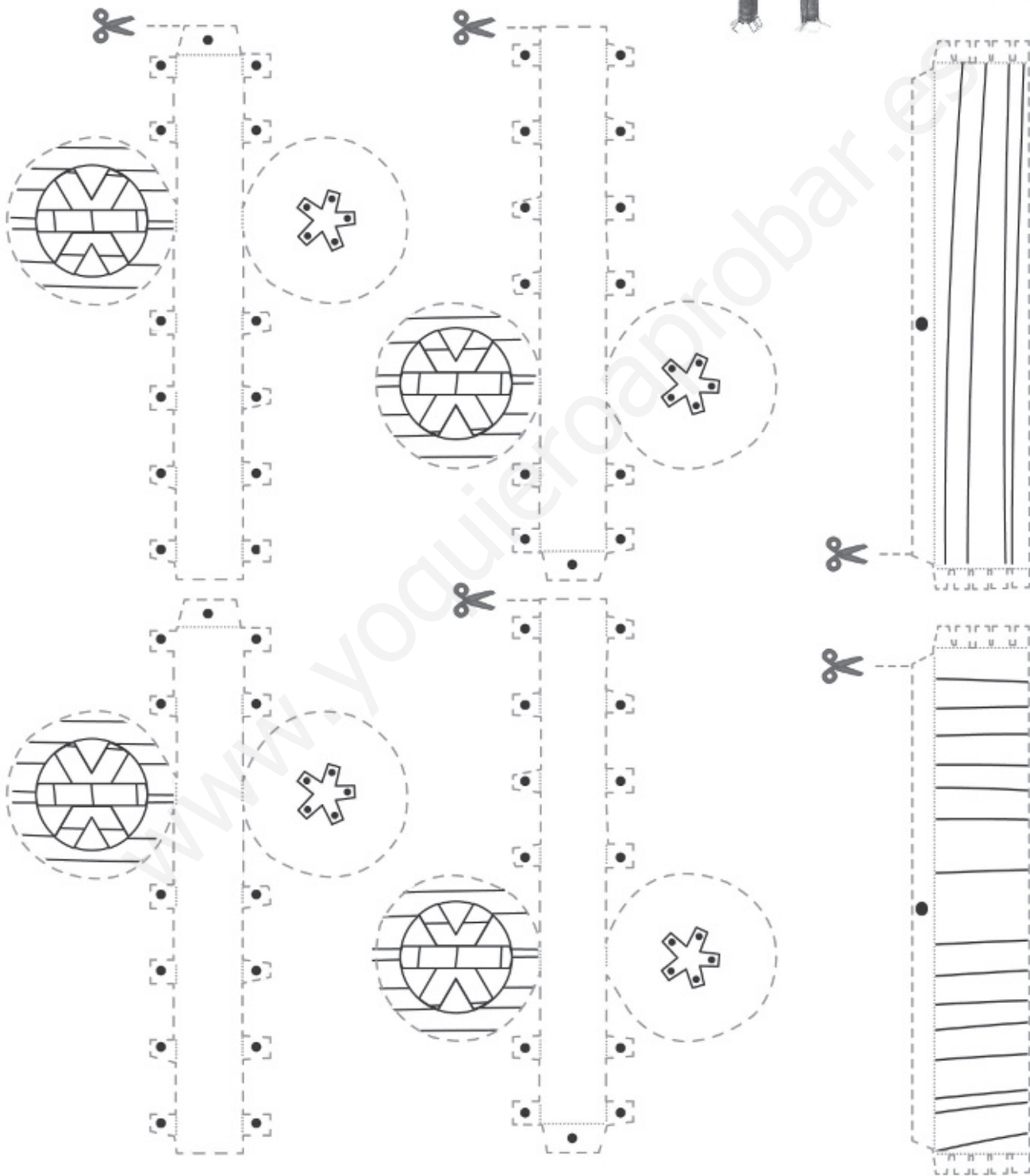
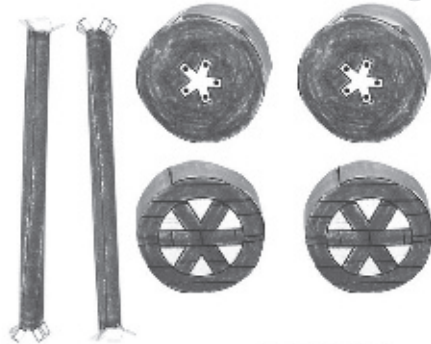
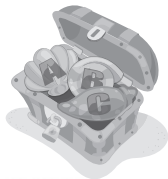

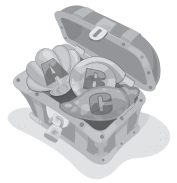

Halloween 3

A Jack-o-lantern 1

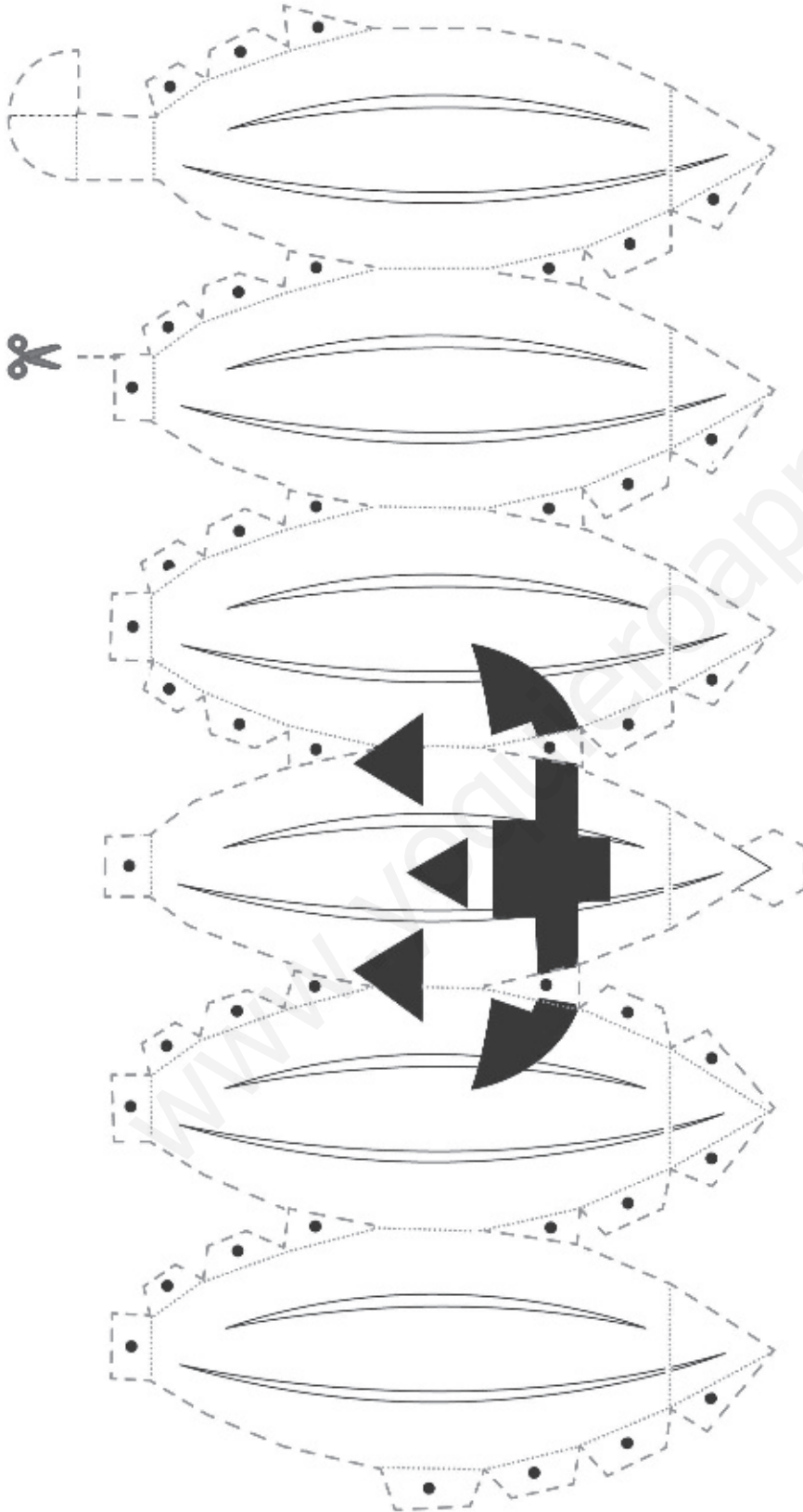

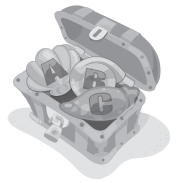

Halloween 4

A Jack-o-lantern 2   

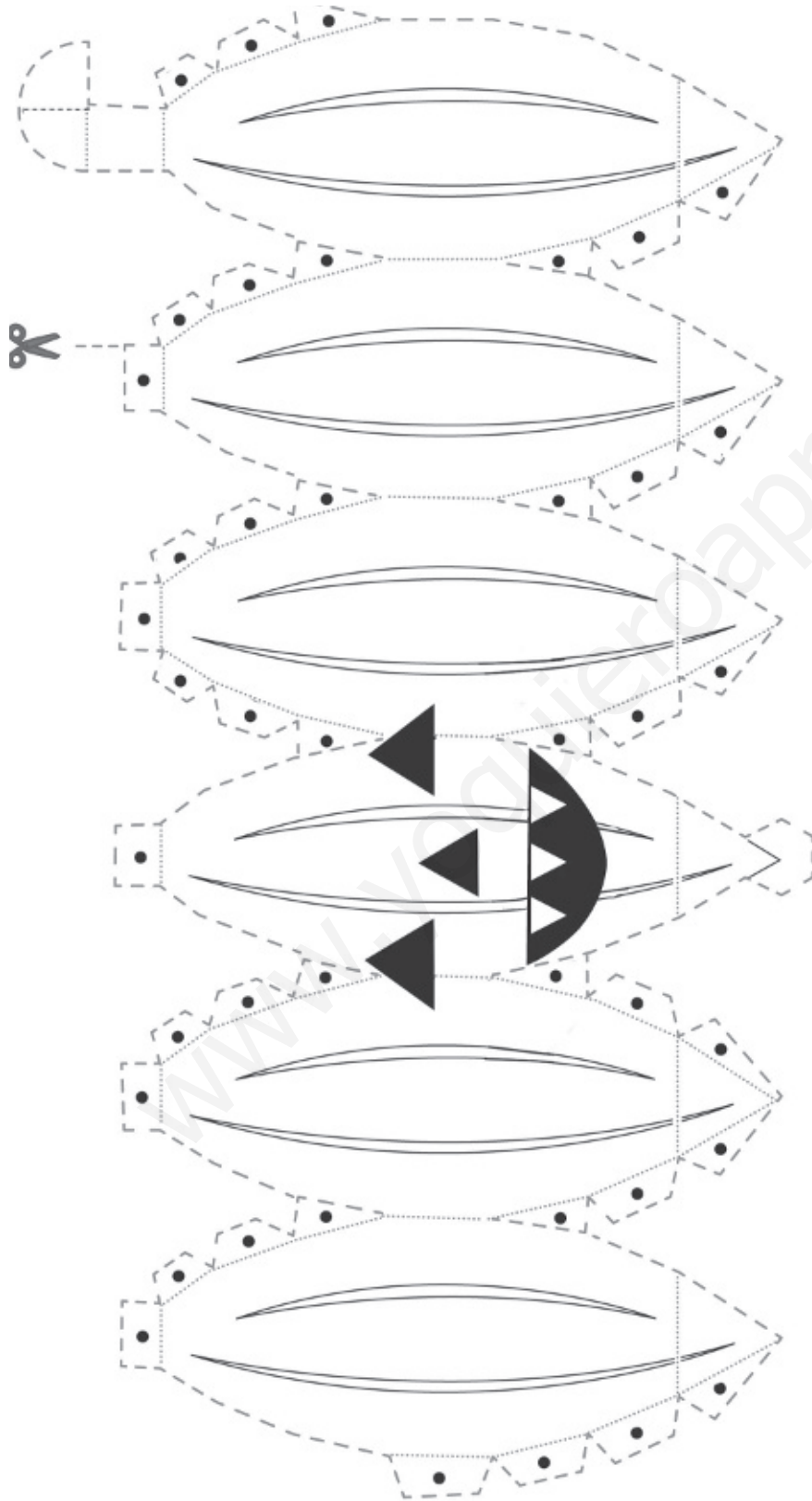



Thanksgiving 1

A Turkey 1   





Thanksgiving 2

A Turkey 2   

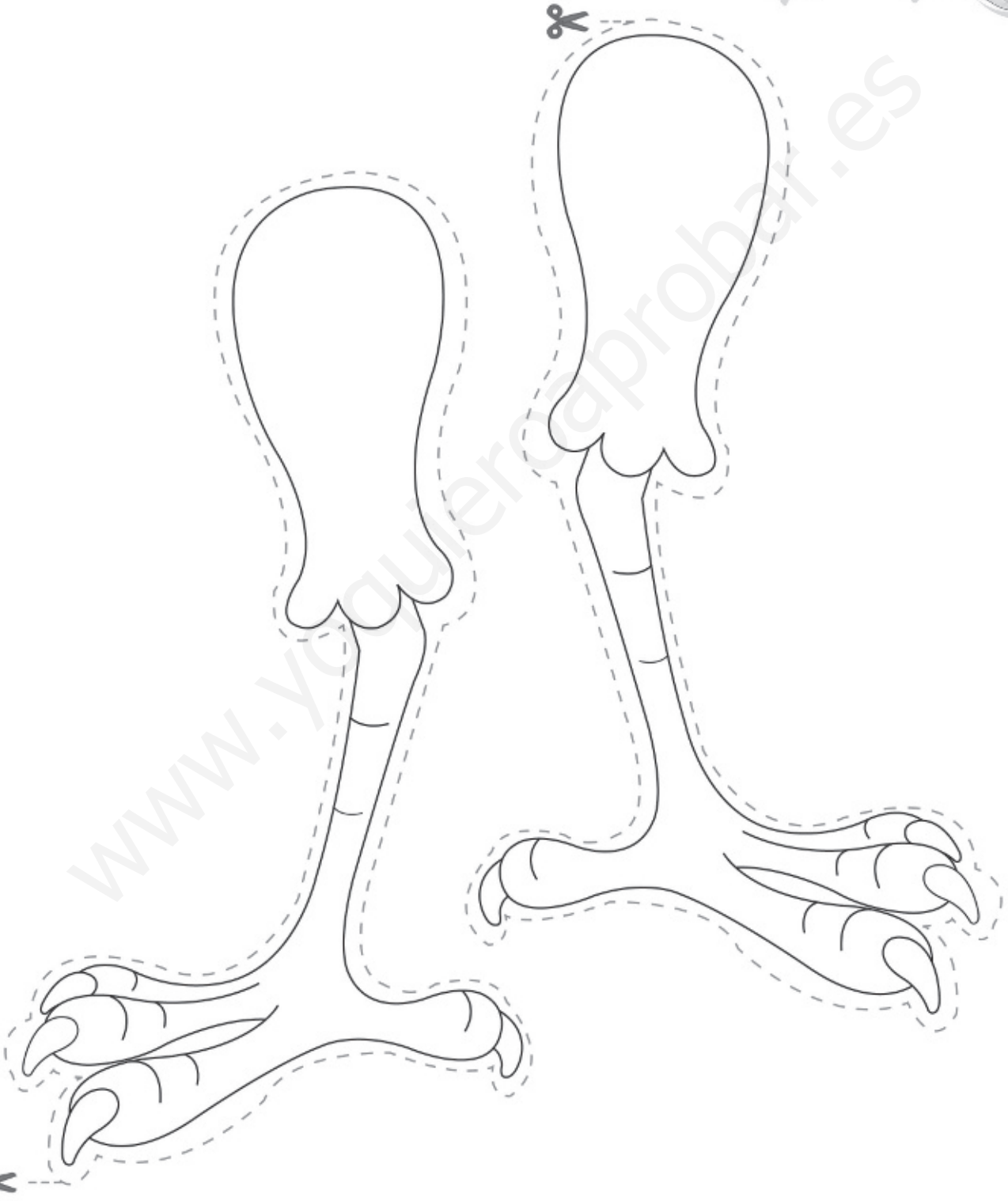



Thanksgiving 3

A Turkey 3

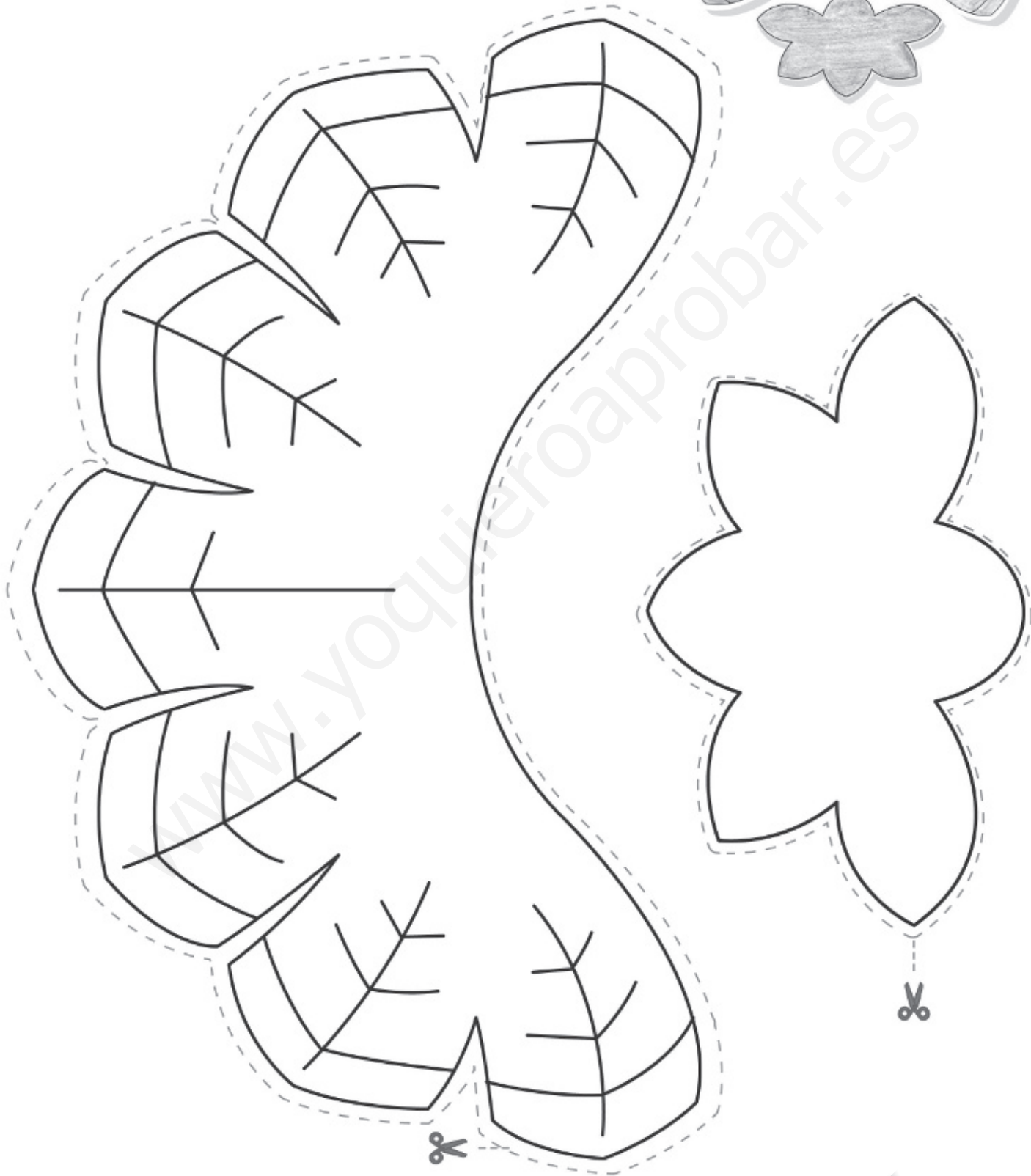
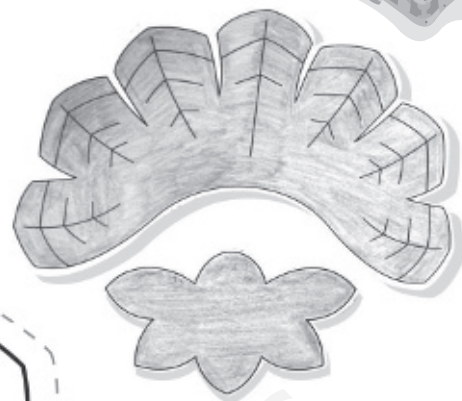



Thanksgiving 4

A Turkey 4   

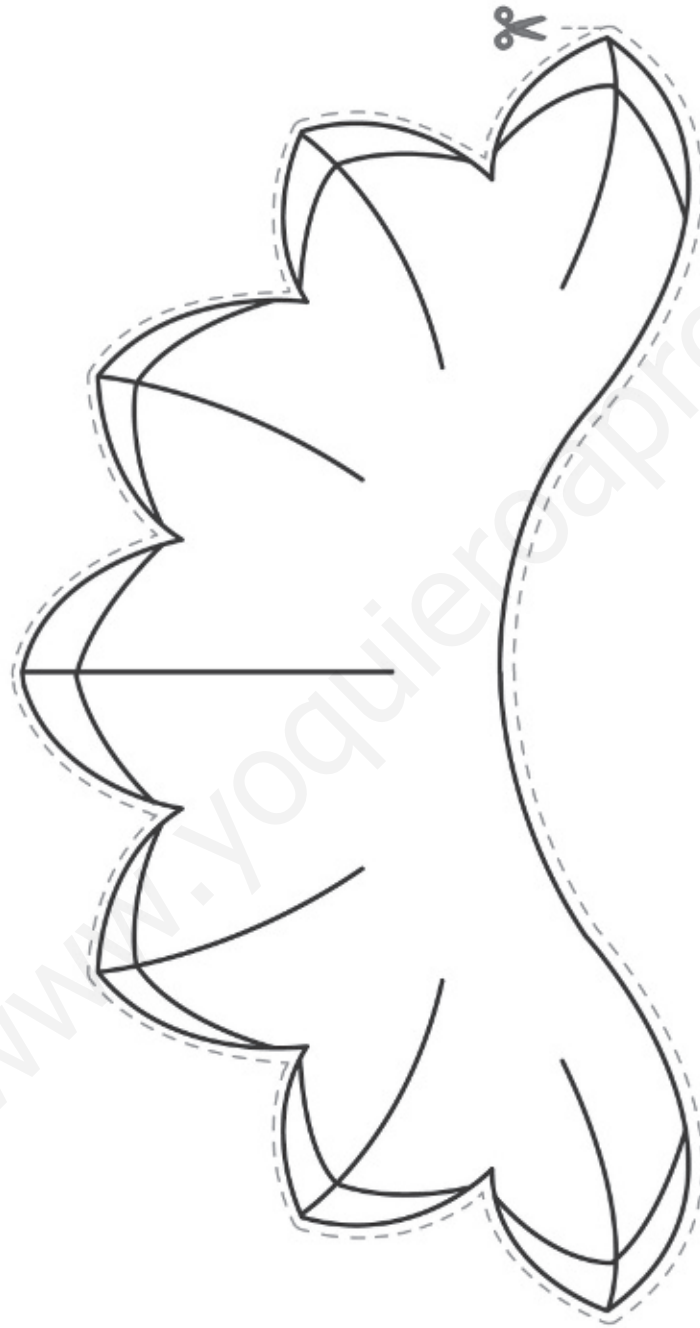
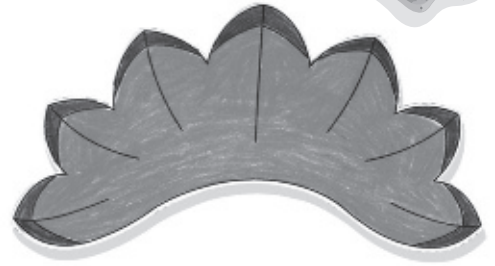
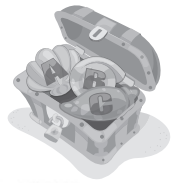



Christmas 1

A Christmas tree 1   

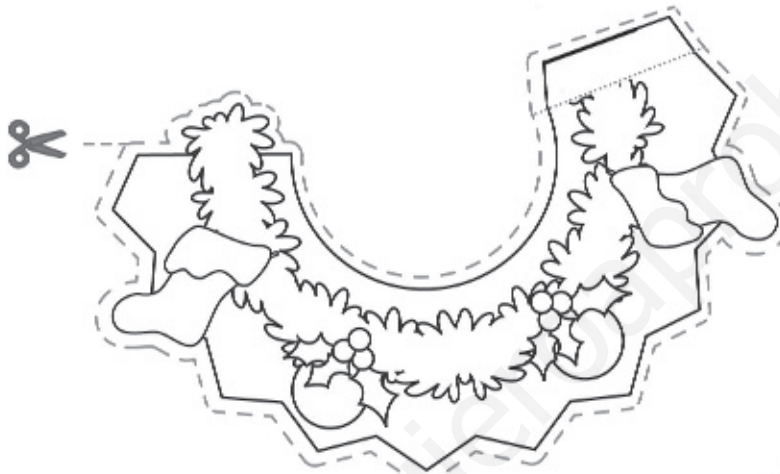
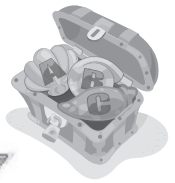

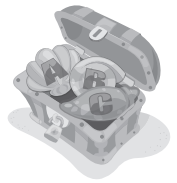

Christmas 2

A Christmas tree 2

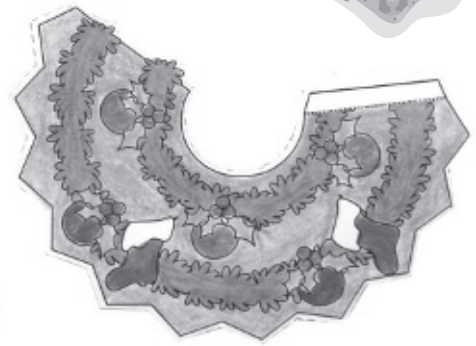



Christmas 3

A Christmas tree 3

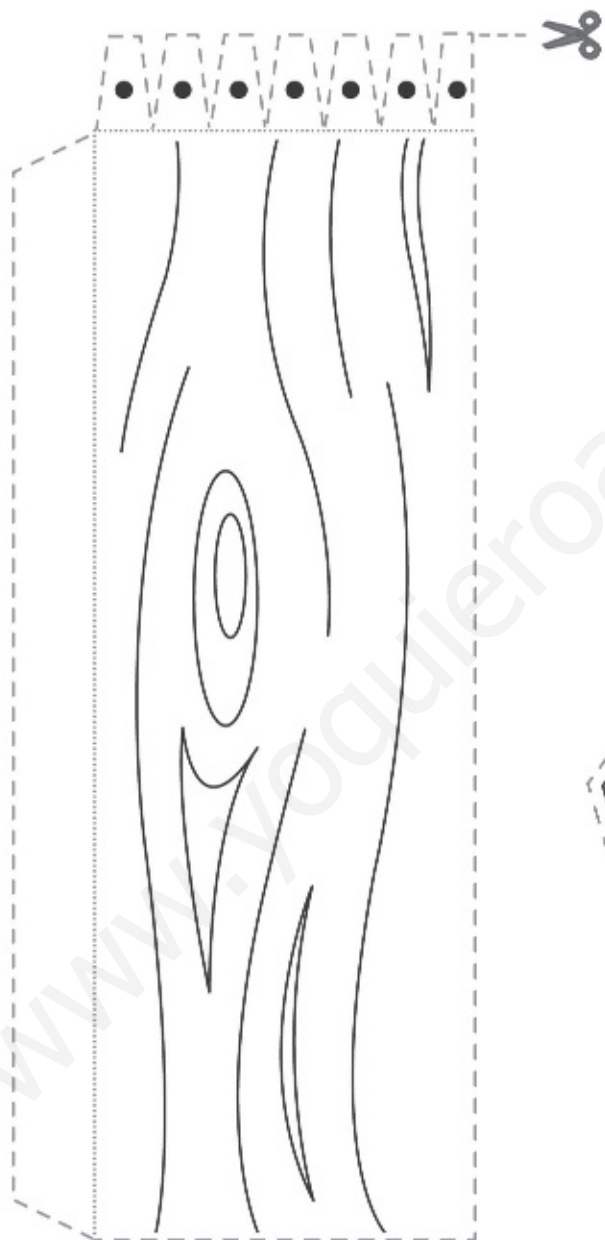



Easter 1

Easter eggs 1

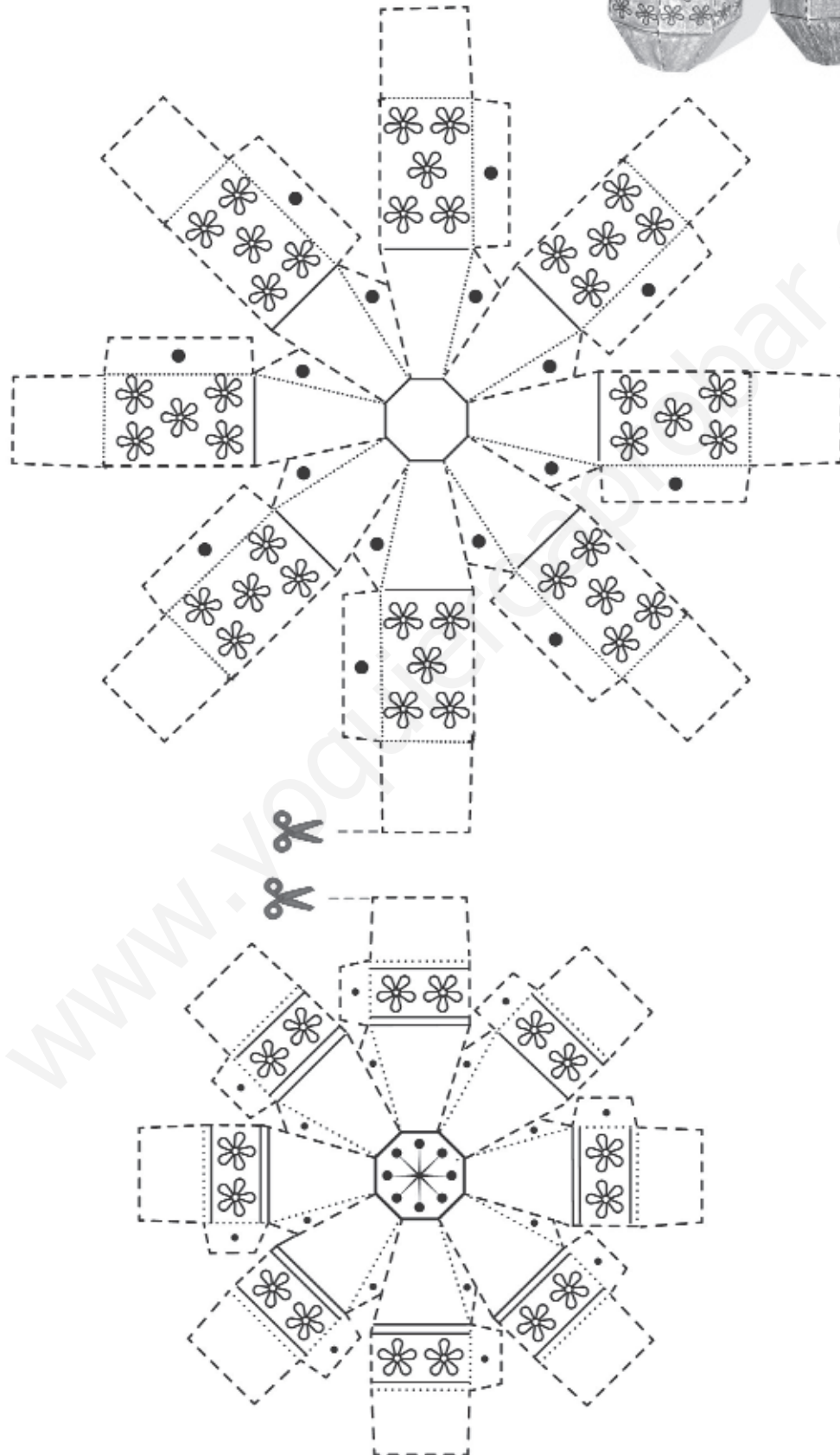



Easter 2

Easter eggs 2   

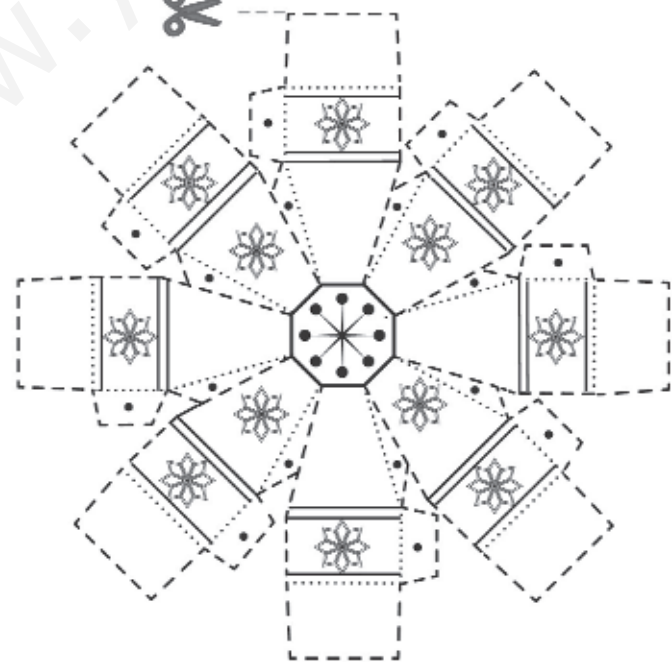
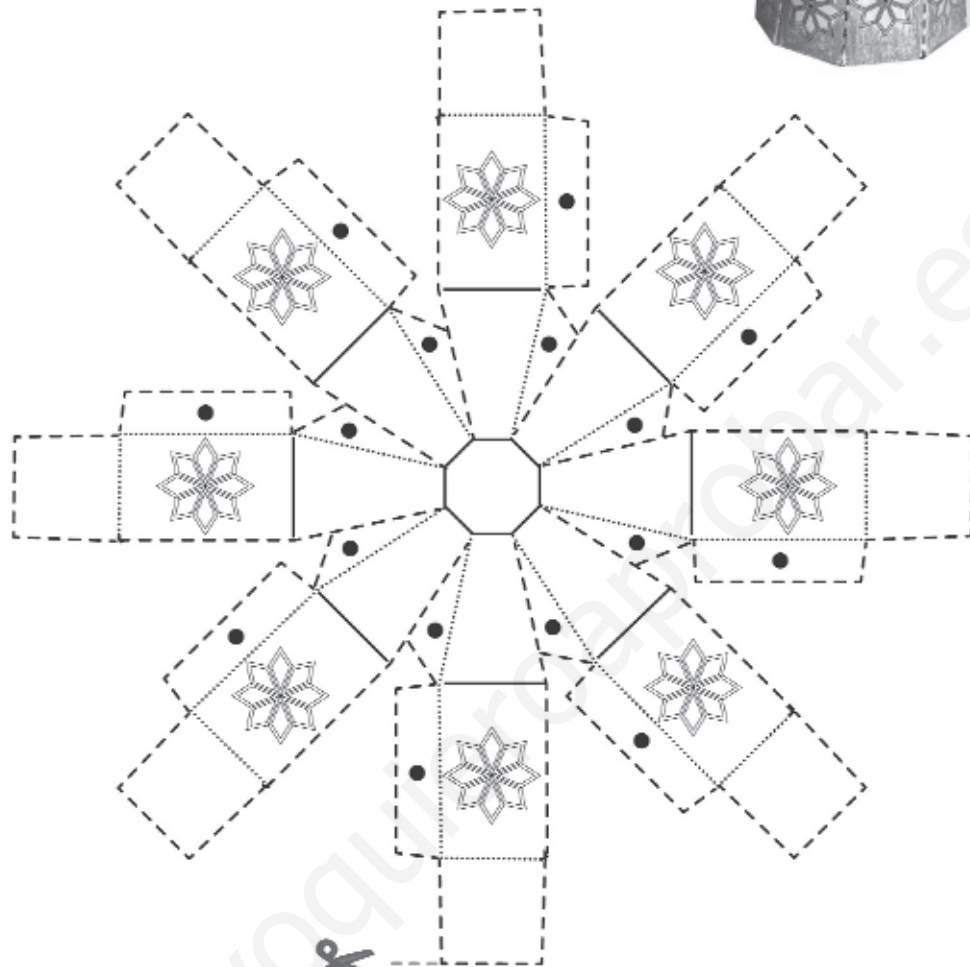



Easter 3

Easter eggs 3

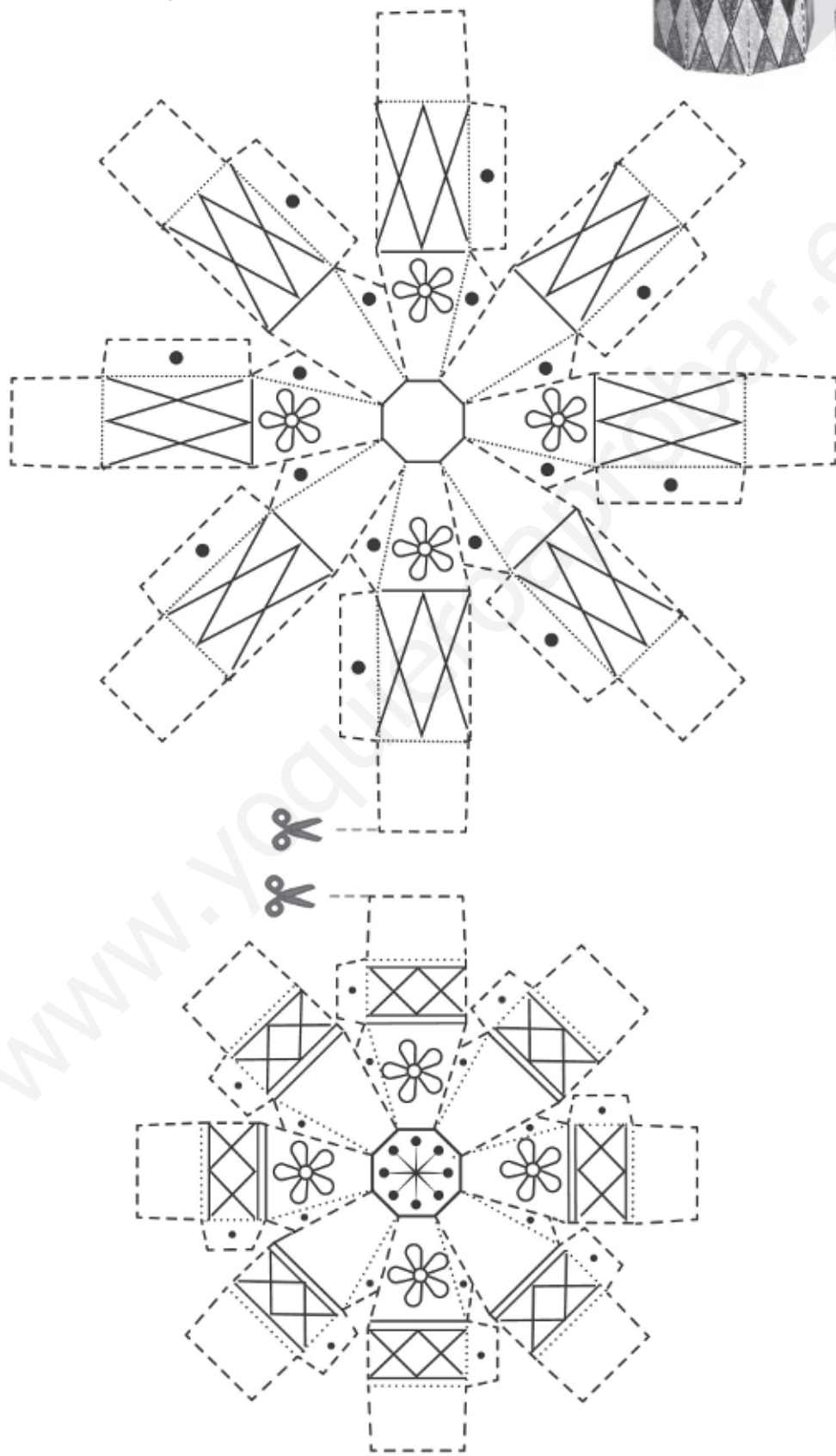



Mother's Day 1

A Rose 1

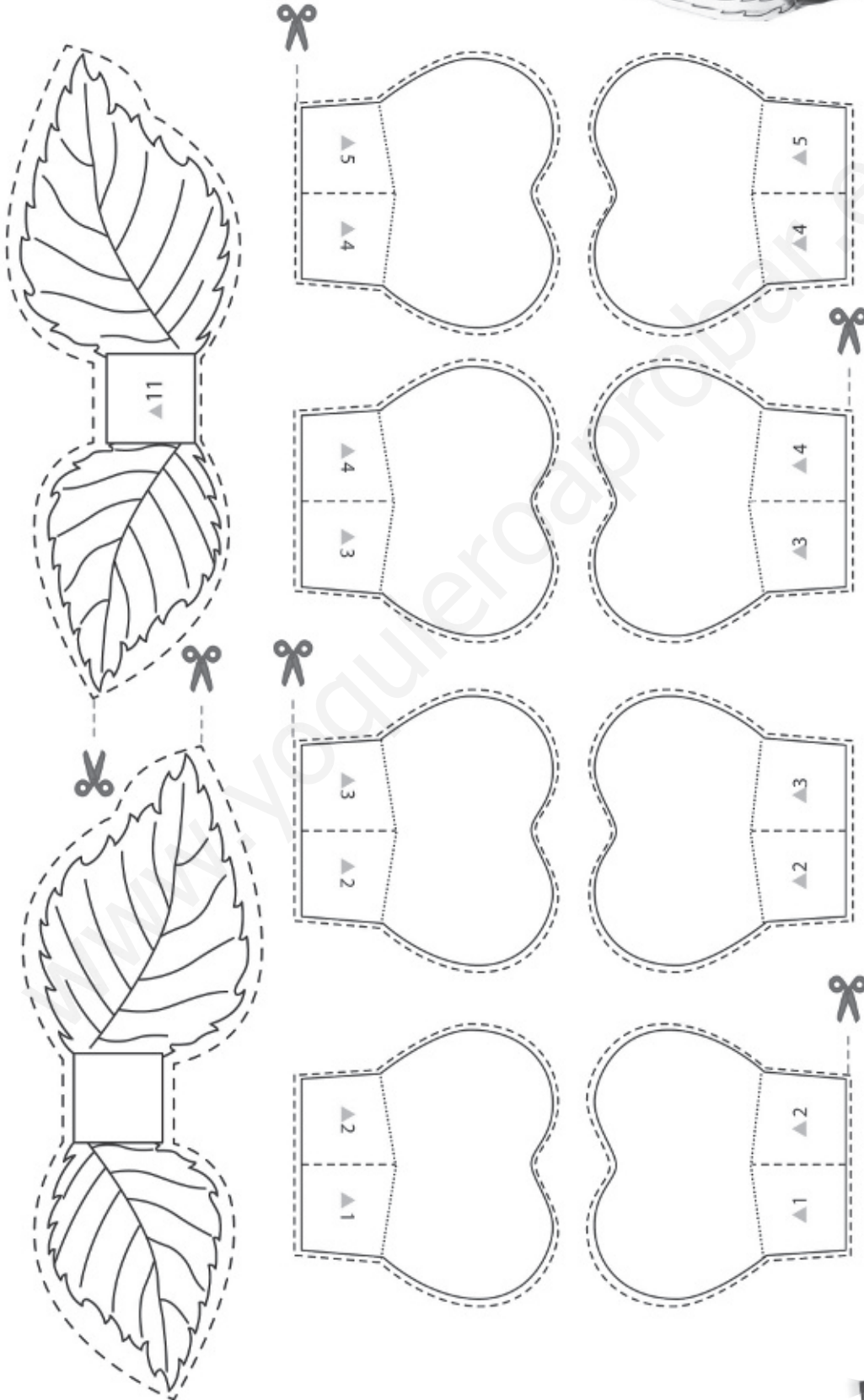
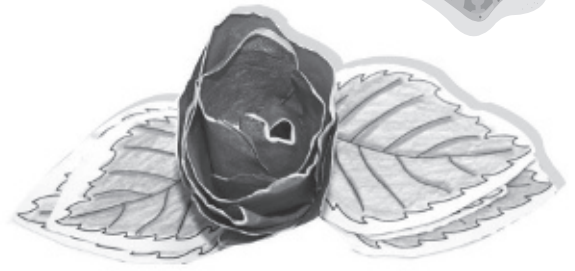



Mother's Day 2

A Rose 2

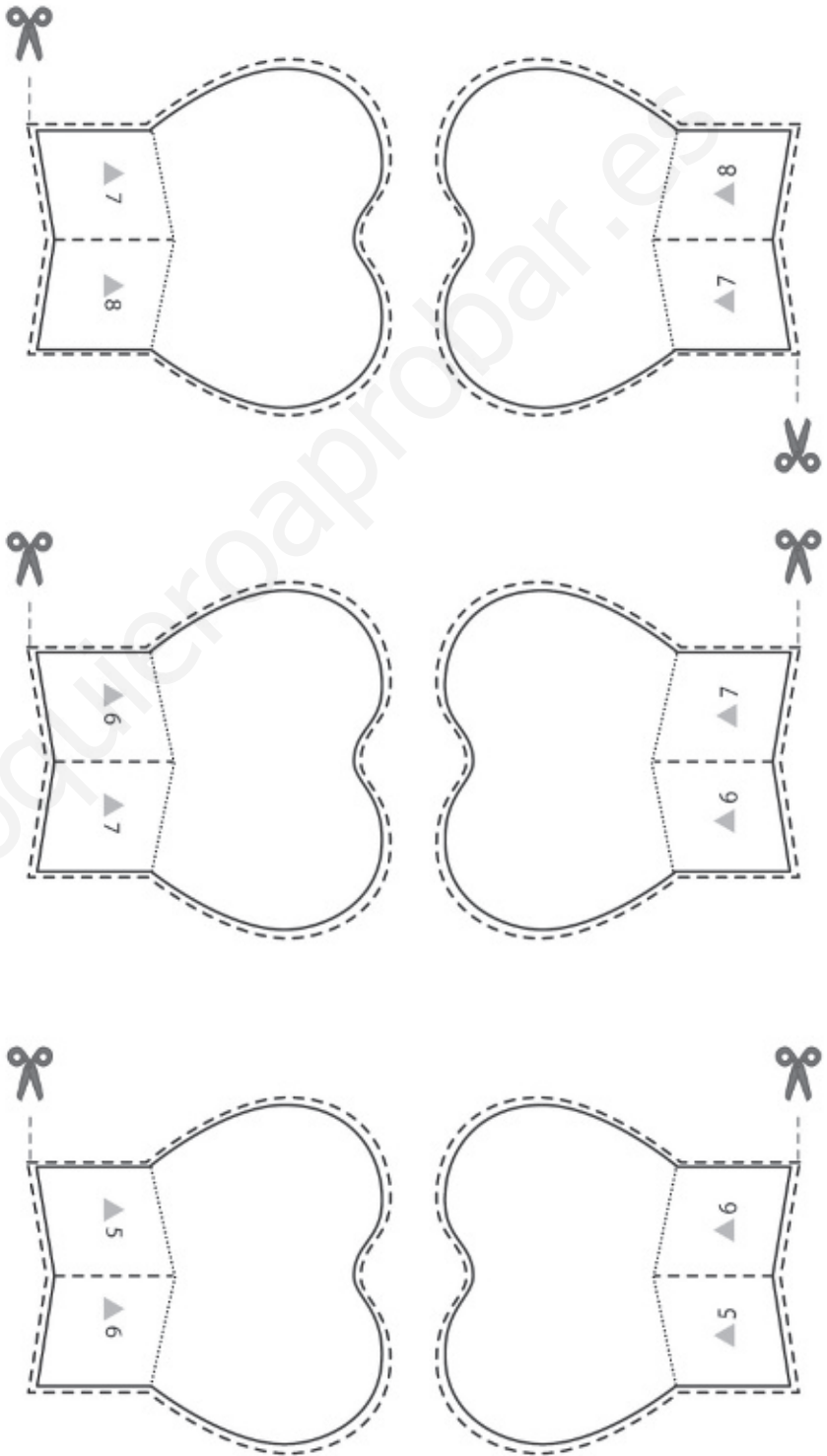
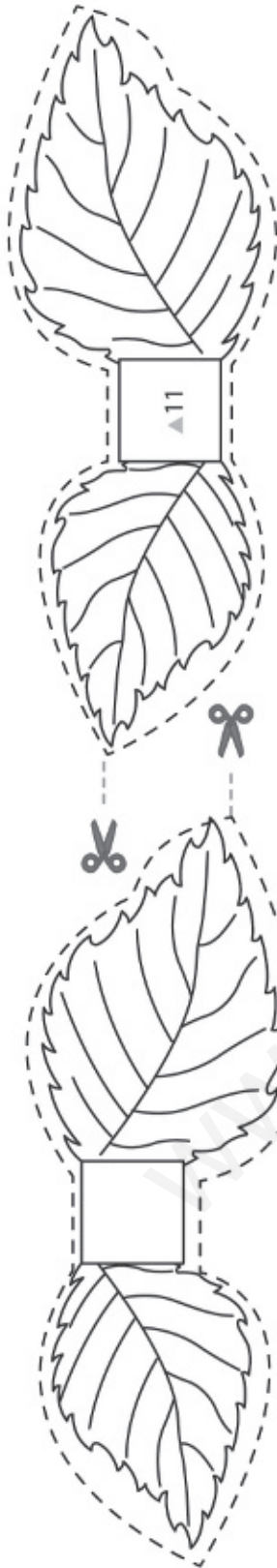
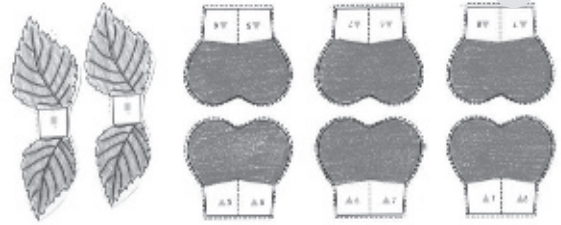



Mother's Day 1

A Rose 3

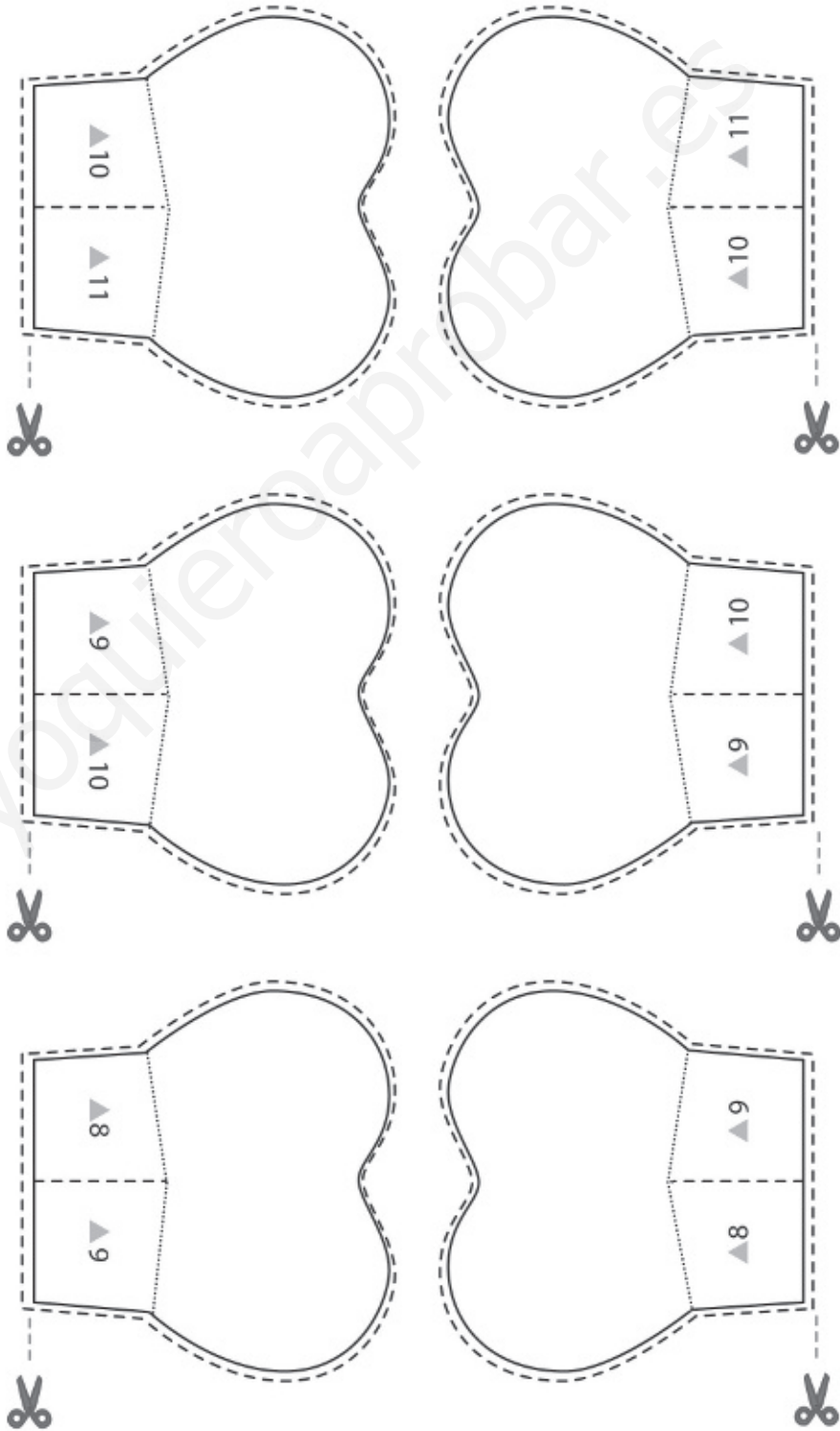
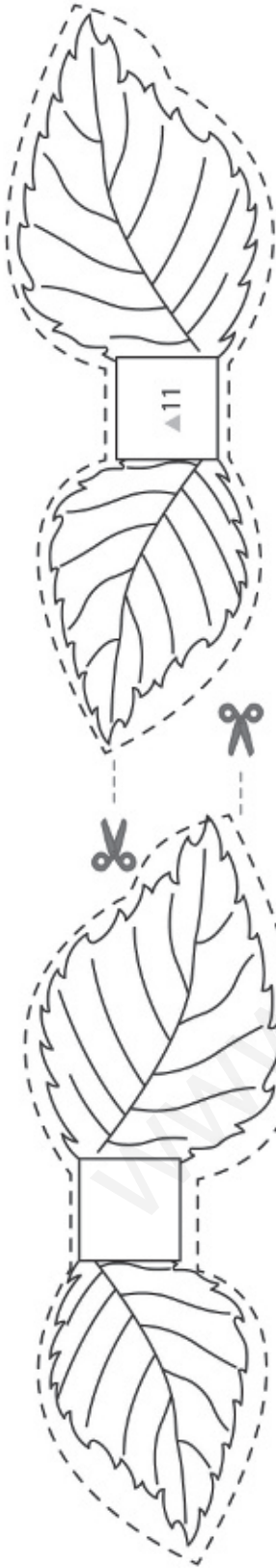
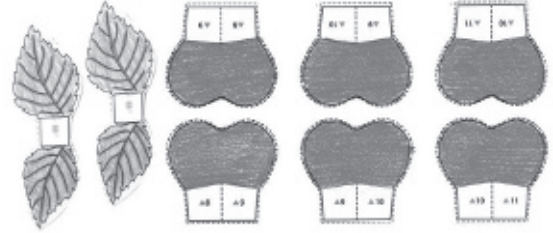



DVD



* Animated Reader: Rubbish Rivals

Teacher's Notes	22
Worksheet 1	24
Worksheet 2	25
Worksheet 3	26

* Real Kids:

School Interviews	27
Money and Clothes	28
Birthdays	29
Travelling	30
Unusual Hobbies	31
Life at Home	32
Pets and vets.	33
Best friends.	34
DVD Scripts	35
Answers	39



www.yoquieroaprobar.es





Rubbish Rivals

Before you read

Tell the class that the story is about a man who invents a recycling machine. Explain that most people in Europe throw away 10 times their bodyweight in rubbish every year and that we need to reuse and recycle things a lot more. Write *Recycle* and *Reuse* as headings on the board and elicit one or two things that people recycle and reuse. Then ask the children to work in pairs and make a list under each heading. For example:

Recycle: drinks cans, plastic milk bottles, newspapers.

Reuse: paper clips, plastic bags, plastic drinks bottles.

Share ideas as a class and discuss what the children recycle and reuse at home and at school.

While you read

Stop reading at the bottom of page 10 where Lady Goff says *I'll destroy you*. Read out the following True/False statements to check comprehension of the story so far: *There's an explosion at Wally Walker's house* (True); *Specks invents a robot* (False, it's a recycling machine); *The recycling machine is perfect* (False); *The big man called Clott is taking photos of the Walkers* (True); *Clott works for Lady Goff* (True); *Sir Mortimer's got a son called David* (False, his name's Henry); *Lady Goff wants the recycling machine* (True).

After you read

Brainstorm things children can do to be "green" and write them on the board: *reuse plastic bags, turn off lights, write on both of a piece of paper, recycle plastic bottles, give clothes to a charity shop, buy recycled paper, etc.* Give each child a sheet of recycled paper and ask them to draw a big leaf shape on the paper. In the leaf, tell them to write a green resolution. For example: *I'm going to reuse plastic bags, I'm going to recycle drink cans, etc.* The children then decorate their leaves and cut them out. Collect the leaves and stick them to a tree trunk and branches made of card on a display board.

Using the worksheets

Worksheet 1

Complete the character descriptions.

Ask the children to look at the picture and description of Lady Goff and ask *Do you like Lady Goff?* Elicit children's answers and reasons. Next, write the following answers on the board: *America/Sir Mortimer Goff/big/Wally Walker/black*. Tell the students to work in pairs and complete the description of Lady Goff with the answers. Give the class two minutes and then check answers: *She's got big eyes and wears a black dress. She is married*

to Sir Mortimer Goff. She's from America. She hates Wally Walker.

Write the answers for the other character descriptions in random order on the board and ask the children to complete them:

Specks: *glasses; recycling machine; Wally Walker; password*

Wally Walker: *Tom; Lady Goff; fat; Lizzie; Lady Goff; Clott*

Clott: *works; recycling machine; T-shirt; Specks; rats*

Worksheet 2

How green are you? Tick (✓) the right answers for you.

Explain to the class that they are going to do a questionnaire about being "green" and helping protect the environment. Write the first question on the board: *Do you turn off the TV when you're not watching it? always/sometimes/never*. Check that the children understand the question and adverbs then ask volunteers for their answers to the question.

Hand out the questionnaires and explain the following vocabulary: *charity shop* (question 5); *tap, brush your teeth* (question 8); *heating* (question 9). Tell the children to complete the questionnaires. Then tell them to total their scores and read the corresponding comment. Ask volunteers to tell the class what score they got in the questionnaire and about the things they do to be "green".

Worksheet 3

Crack the code!

Hand out the worksheets and ask the children to look at the grid. Explain that it shows a code. Then tell the children to look at the first code word. Using the grid, work out the first word as a class. Then tell the children to use the grid to work out the remaining words. Check answers as a class.

Finally, ask the children to each think of a word and then represent the letters of the word with symbols from the grid. Children exchange codes with a partner and then crack each other's codes.

Extension

Prepare a notice on recycled paper that says: *Be green! Turn off the light*. Illustrate it with a picture of a finger turning off a switch. Show the class the notice and tell them that they are going to make some notices to put up at home to remind the people in their family to take care of the environment. Elicit ideas for the notices: *Turn off the TV when you're not watching it, Reuse plastic bags*. Then give each child three pieces of paper and tell them to prepare three notices. Encourage the children to show the notices to their family and display them at home.



Rubbish Rivals Answers

Worksheet 1

Complete the character descriptions.

- 1 big - black - Sir Mortimer Goff - America - Wally Walker
- 2 Wally - glasses - recycling machine - password
- 3 fat - Lady Goff - Tom - Lizzie - Clott - Lady Goff
- 4 T-shirt - works - rats - Specks - recycling machine

Worksheet 2

How green are you? Tick (✓) the right answers for you.

Student's own answers

Worksheet 3

Crack the code!

- 1 tunnel
- 2 rat
- 3 password
- 4 batteries



Rubbish Rivals

Name: _____ Class: _____

Complete the character descriptions.



She's got _____ eyes and wears a _____ dress. She is married to _____. She's from _____. She hates _____.

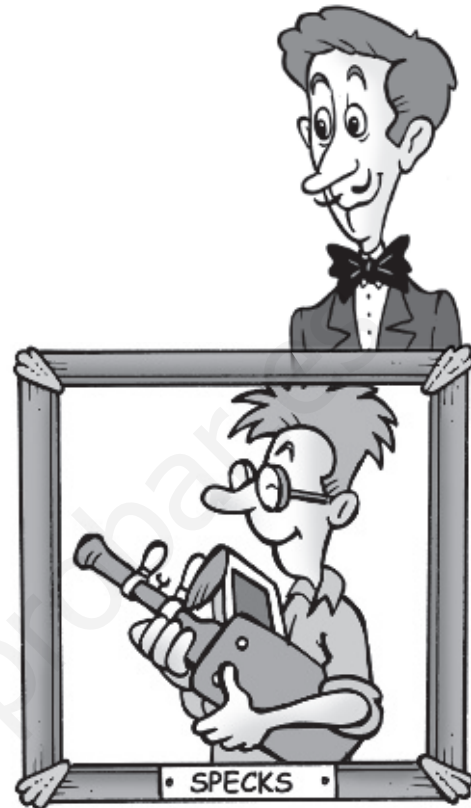

He's _____'s friend. He wears _____ because he can't see well. He invented a _____. He tells Lady Goff the _____ to save his friends.



He's not thin, he's _____. He is _____'s rival. He's _____ and _____'s dad. He chases _____. He didn't want to marry _____.



He wears a green _____. He's not very intelligent. He _____ for Lady Goff. He's frightened of _____. He hits _____ on the head. He helps to steal the _____.



Rubbish Rivals

Name: _____ Class: _____

How green are you? Tick (✓) the right answers for you.

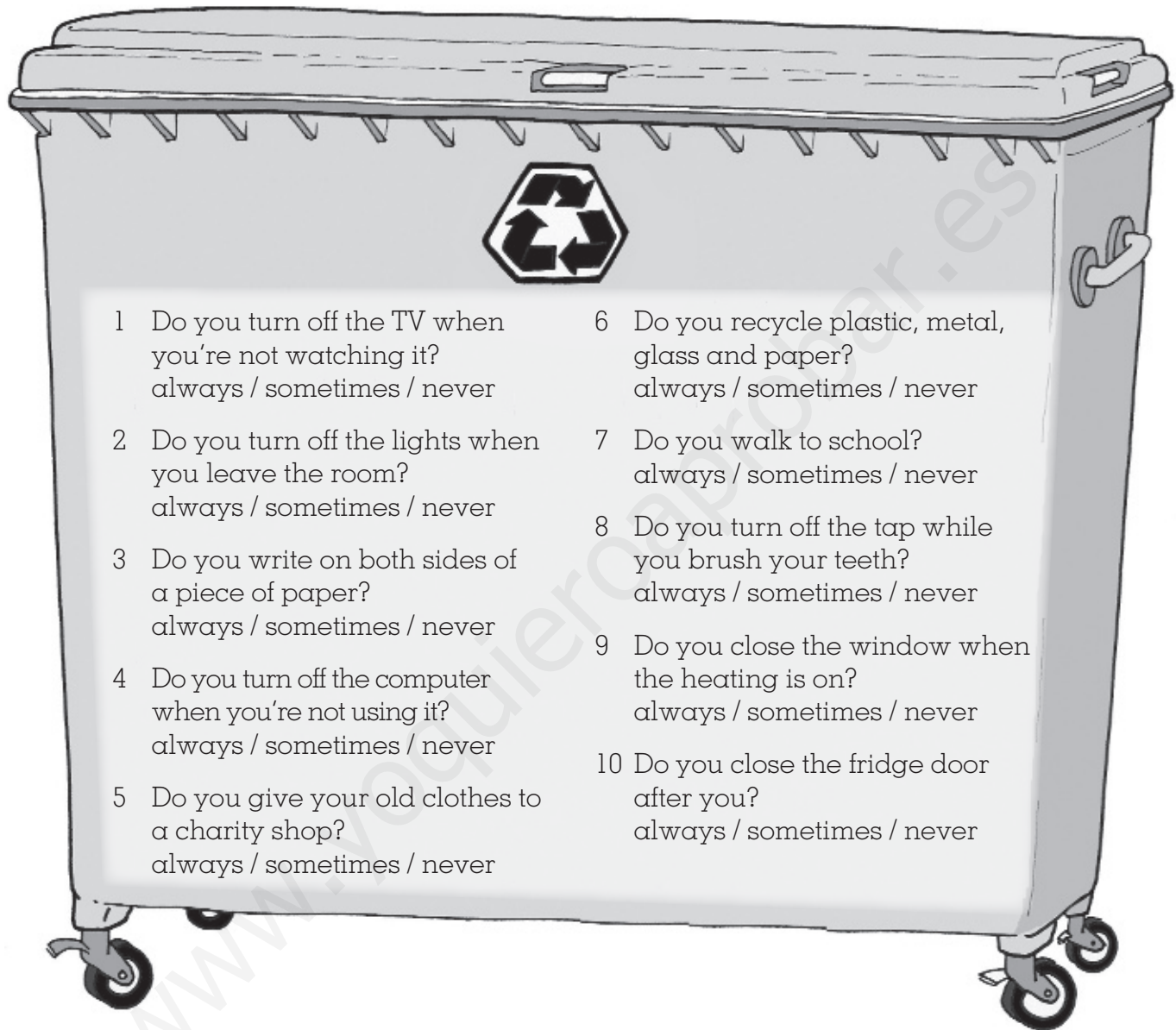

- | | |
|--|---|
| 1 Do you turn off the TV when you're not watching it?
always / sometimes / never | 6 Do you recycle plastic, metal, glass and paper?
always / sometimes / never |
| 2 Do you turn off the lights when you leave the room?
always / sometimes / never | 7 Do you walk to school?
always / sometimes / never |
| 3 Do you write on both sides of a piece of paper?
always / sometimes / never | 8 Do you turn off the tap while you brush your teeth?
always / sometimes / never |
| 4 Do you turn off the computer when you're not using it?
always / sometimes / never | 9 Do you close the window when the heating is on?
always / sometimes / never |
| 5 Do you give your old clothes to a charity shop?
always / sometimes / never | 10 Do you close the fridge door after you?
always / sometimes / never |

Now add up your score and see how green you are!

Always=2 Sometimes=1 Never=0

- 15 to 20 = You care about the environment. Keep up the good work!
- 10 to 15 = You are not bad, but you can be better!
- 0 to 10 = You need to try harder!





Rubbish Rivals

Name: _____ Class: _____

Crack the code!

	□	○	◇	△	☆
■	a	b	c	d	e
●	f	g	h	i	j
◆	k	l	m	n	o
▲	p	q	r	s	t
★	u	v	w	x	y













Real Kids: School Interviews

Name: _____ Class: _____

1 Where do you live? What buildings are near you? Tick (✓) the buildings.

hospital

library

school

shopping centre

police station

supermarket

chemist

restaurant

2 Watch and listen. What subjects do the children study?

1 Jasmine	Chemistry	Maths	French	English
2 Camilla	French	English	Art	Maths
3 Suresh	Maths	English	History	Science
4 Georgina	History	French	Maths	Science
5 Indira	Art	Science	History	Maths

3 Complete the sentences about Alex.

1 We get to school at _____.

2 We have to wear our _____.

3 We have to do our _____.

4 We have to wear a red _____, black _____ and black _____.

5 Today, for example, we have _____ and _____.

6 We call our teachers _____ or _____.

4 Work with a partner and write about your school. Use the notes.

- size
- age of students
- timetable
- subjects
- sports
- your opinion



Real Kids: Money and Clothes

Name: _____ Class: _____

1 Work in groups and talk about clothes.

What do you like wearing?

I really like wearing jeans.

2 Watch and listen. Then circle T (true) or F (false).

- 1 Spitalfield's market used to sell books and games. T F
- 2 Victoria buys clothes with her pocket money. T F
- 3 Teenagers spend about 40 pounds on clothes. T F
- 4 Maddy makes a lot of her own clothes. T F
- 5 Grazia spends the most on clothes. T F
- 6 Frank likes buying expensive clothes. T F

3 Complete the sentences with the words in the box.

favourite jacket bag suits top

- 1 My favourite item at the moment is this _____.
- 2 My favourite piece of clothing is this _____.
- 3 Oh, usually one of my uncle's old _____.
- 4 I've got a really nice _____.
- 5 What's your _____ piece of clothing?

4 Write about your shopping habits.

1 What clothes do you like wearing?

2 Where do you usually buy your clothes?

3 How much money do you usually spend?

4 What's your favourite item of clothing?



Real Kids: Birthdays

Name: _____ Class: _____

1 Work with a partner and ask about your family members' birthdays.

When is your mum's birthday?

It's on 7th September.

2 Watch and listen. Answer the questions about Charlotte.

1 What is Charlotte's present?

4 What can you see out of the window?

2 What is Charlotte's brother's name?

5 Who is at the door?

3 What is Charlotte's brother doing?

3 Complete the sentences with the words in the box.

upstairs semi-detached doorbell bungalow
birthday cards satellite TV

1 Come and see my _____!

2 My house is _____ and I've got a big garden.

3 I live in a _____.

4 We've got _____.

5 Let's go _____.

6 Oh! That's the _____.

4 Choose three houses from the box and write a description.

cottage bungalow igloo flat castle mansion



Real Kids: Travelling

Name: _____ Class: _____

1 Talk about what you know about the countries in the box.

Australia Spain England USA

Watch and listen. Circle *True* or *False*.

- 1 Victoria is going to Australia with her French class. True False
- 2 A travel agent's is organising the trip. True False
- 3 They are going to Ayers Rock, then Sydney. True False
- 4 Victoria needs to get a vaccination. True False
- 5 The currency in Australia is the dollar. True False
- 6 Victoria asks for 270 pounds in cash. True False

2 Complete the sentences with the words in the box.

time tomorrow going centre everything want

They're all _____ to Australia.

But we'll go to the travel agent's _____.

It's got the sea, beaches, shops... _____.

You're staying at a hotel by The Rocks, which is right in the _____ of the city.

All right. Have a lovely _____.

Sure, how much do you _____?

3 Work with a partner and find information about Australia. Use the notes.

- currency
- monuments
- language
- vaccination
- traditions





Real Kids: Unusual Hobbies

Name: _____ Class: _____

1 Tick (✓) the free time activities that you do.

- | | | | | | |
|--------------------|--------------------------|---------------------|--------------------------|--------------------|--------------------------|
| going swimming | <input type="checkbox"/> | playing football | <input type="checkbox"/> | playing basketball | <input type="checkbox"/> |
| listening to music | <input type="checkbox"/> | going to the cinema | <input type="checkbox"/> | reading | <input type="checkbox"/> |
| going shopping | <input type="checkbox"/> | using the internet | <input type="checkbox"/> | cooking | <input type="checkbox"/> |

2 Watch and listen. Answer the questions.

1 What do The Agents do in their free time?

2 How do they get the money?

3 Name four sports that Sara and Yossie like playing.

4 What do Crystal and Melissa both like?

5 Do Susie and Zoe like animals?

6 What does Pete like doing in his free time?

3 Complete the sentences with the words in the box.

make history years ago free time hat car park

1 It's in a supermarket _____.

2 Films are expensive to _____.

3 We usually make the films during our _____.

4 This is my Jamaican _____.

5 The thing I like about coins is that it's holding _____ in your hand.

6 I started collecting about thirteen _____.

4 Discuss what you enjoy doing in your free time. Make a class chart to show the most popular hobbies.



Real Kids: Life at Home

Name: _____ Class: _____

1 Talk about your plans for the weekend as a class.

What are you doing this weekend?

I'm going to the cinema with my friends.

2 Watch and listen. Put these questions in the order in which they are mentioned.

- | | | | |
|--|--------------------------|---|--------------------------|
| 1 How late can you stay out? | <input type="checkbox"/> | 5 What jobs do you do around the house? | <input type="checkbox"/> |
| 2 How do you get on with your family? | <input type="checkbox"/> | 6 Can I borrow ten pounds? | <input type="checkbox"/> |
| 3 Haven't you got work for tomorrow? | <input type="checkbox"/> | 7 Where are you going bowling? | <input type="checkbox"/> |
| 4 What's the right amount of pocket money? | <input type="checkbox"/> | | |

3 Answer the questions.

- | | |
|--|--|
| 1 What does Victoria want to do?
_____ | 5 How much does Georgina think the right amount of pocket money is?
_____ |
| 2 Why hasn't she got any money?
_____ | 6 What jobs does Zoe do around the house?
_____ |
| 3 What time does she have to be home?
_____ | 7 Who does Suresh get on well with?
_____ |
| 4 How late can Harbanz stay out?
_____ | |

4 Write about you and your family. Use the notes to help you.

- What do you do at weekends?
- How late can you stay out?
- How much pocket money do you get?
- What jobs do you do around the house?
- How do you get on with your family?



Real Kids: Pets and vets

Name: _____ Class: _____

1 Talk about your pets as a class. Who's got the strongest pet?

Have you got any pets?

Yes, I've got a snake!

2 Watch and listen. Circle True or False.

1 Victoria's cat is called Billy. True False

2 The man's dog is a Dalmatian. True False

3 Nobody likes the old lady's dog. True False

4 The man bought his dog at a pet shop. True False

5 Dalmatians are boring pets. True False

6 The old lady's dog eats everything! True False

7 Billy is sick. True False

3 Complete the sentences with the words in the box.

walks food like get special company

1 What's _____ about your pet?

2 Where did you _____ him or her from?

3 What do you _____ about him or her?

4 I like him because he keeps me _____.

5 She eats dried _____.

6 We go for long _____ in the country.

4 Write about your ideal pet.



Real Kids: Best friends

Name: _____ Class: _____

1 Complete the adjectives.

a_u_i_g

b_s_y

k_n_

f_n_y

g_n_r_u_

l_v_n_

2 Watch and listen. Underline the correct option.

- 1 Dumani and Sean like / don't like doing the same things.
- 2 Peter and Rosita have known each other for twenty / thirty years.
- 3 Sara is very loud and very amusing / bossy.
- 4 Zoe is very nice / beautiful and very kind and funny.
- 5 Sara likes going clubbing in Manchester / London.
- 6 Susie and Zoe always / sometimes like cooking together.
- 7 Sean's a brilliant skater / runner.
- 8 Melissa is good / bad at keeping secrets.

3 Complete the sentences with the words in the box.

shopping	quite	together	wakes up
around	loyal	generous	bus stop

- 1 She's good to be _____.
- 2 She's _____ and compassionate.
- 3 We like _____ and playing Monopoly.
- 4 We all go out _____ and have a good time.
- 5 We go to the beach _____ a lot.
- 6 We met at the _____.
- 7 Yossie always _____ too early.
- 8 A good friend is _____.

4 Write about your best friend.



School Interviews

Victoria: This is a public school. Well, actually it's a private school. Most parents pay a lot of money for their children to come here.

Jasmine: My name is Jasmine and I come from Hong Kong. My typical day starts off with swimming in the morning at six o'clock. Then I have breakfast in the house and then I have double Chemistry in the science labs. After double Chemistry I have double French in the language centre and then I have double volleyball in the hall. Hopefully, when I leave I'm going to go to university but I'm not sure what I'm going to do.

Victoria: What subjects do you study?

Camilla: I study French, English, Art and Philosophy.

Suresh: I study Maths, English, Science, Media Studies, French, History and IT.

Georgina: I study French, History, Media Studies, Maths and Science.

Indira: I study Art, Science. I study Classical Civilization and Sixteenth Century History.

Victoria: Now, this is a comprehensive school. Education is free and about sixteen hundred students come here. They start at the age of eleven and go on till sixteen or finish at eighteen if they are going on to university.

Alex: My name's Alex. We get to school at quarter to eight and have registration. We have to be at school on time and we have to be punctual to lessons and we have to wear our uniform and we have to do our homework. We have to wear a red jumper, black trousers and black shoes. We have five lessons, which are an hour long each. Today, for example, we have Chemistry and Art. We call our teachers "Sir" or "Miss". I like my school because the classrooms are attractive and we have large playing fields and lots of other activities after school. There's nothing I don't like about my school.

Money and Clothes

Victoria: Hi. This is Spitalfields Market in London. It's a Sunday market. It's open every Sunday. But what exactly can you buy here? This used to be a fruit and vegetable market in the old days. Clothes here are a bit more expensive than other markets. How do you get the money? I save up my pocket money and do odd jobs for my parents. Some kids have part-time jobs, like delivering newspapers. What do you think? No, I don't like it either. So, what is street fashion?

Woman: I think street fashion is colourful, cheap, it's individual.

Victoria: So, how much are you spending today on clothes?

Woman: I'll probably spend about fifty pounds.

Victoria: What's street fashion?

Stall holder: It's what people wear on the streets.

Victoria: So how much do teenagers usually spend on clothes?

Stall holder: About twenty pounds, not a lot of money.

Victoria: What's street fashion?

Maddy: Street fashion to me is individual clothing.

Victoria: What kind of clothes do you like?

Grazia: I like London street fashion clothes.

Eddie: I like baggy clothes, darker colours, greens, browns, jackets, jeans.

Maddy: I like quite colourful clothes. I make a lot of my own clothes though.

Frank: I like practical clothes. I like warm clothes on a day like today.

Victoria: So, how much do you spend on clothes?

Grazia: I spend about two hundred pounds a month on clothes.

Eddie: I spend between twenty and a hundred pounds a month.

Maddy: Probably about a maximum of about twenty quid.

Frank: I spend as little as possible on clothes.

Victoria: Where do you buy your clothes?

Grazia: At markets or in boutiques or shops in different places in London.

Eddie: I buy all my clothes in the markets. I don't buy any from the shops.

Frank: I buy my clothes anywhere other than London because it's expensive here.

Victoria: What's your favourite piece of clothing?

Grazia: My favourite item at the moment is this bag. It actually comes from Italy.

Maddy: My favourite piece of clothing...I've got a really nice sequined top.

Eddie: My favourite piece of clothing is this jacket.

Frank: My favourite piece of clothing is this because it's got a hood to keep me warm.

Victoria: What do you wear when you want to dress up?

Grazia: When I want to dress up I wear something new in my wardrobe.

Frank: Oh, usually one of my uncle's old suits is what I put on when I want to dress up.

Victoria: I'm going to a party on Saturday. This'll look great. How much is that?

Stall holder: Twenty pounds.

Victoria: Thank you.

Stall holder: Thank you.



Birthdays

Charlotte: Hi, it's my birthday today. Go on, wish me happy birthday.

Kids: Happy birthday!

Charlotte: I'm having a party. Come and see my birthday cards.

Charlotte: I've got lots of birthday cards. There's one from my mum and dad. One from my auntie and uncle. One from my grandma and grandpa. That one's from Russell. And that one's from my best friend. I hope I get lots of great presents!

Charlotte: Mum!

Mum: Close your eyes.

Charlotte: They are!

Mum: Happy birthday, Charlotte!

Charlotte: Thanks, mum. Can I open it?

Mum: Of course.

Charlotte: Wow, it's a printer! Thanks, mum.

Mum: Happy birthday, Charlotte.

Charlotte: Mum!

Russell: Where do you live?

Lauren: I live in a house with a garden.

Daisy: We live in a big house with a garden.

Lucy: My house is semi-detached and I've got a big garden.

Katherine: I live in a bungalow.

David: I live in a flat.

Nicolas: I live in a cottage.

Charlotte: Let me show you our house. Give me the camera. This is the living room. There's the sofa. This is the TV and video. We've got satellite TV. Here's the conservatory. And here's the kitchen. Let's go upstairs. This is Russell's room. He's on the Playstation. Say hi, Russell. There's mum and dad's bedroom. Hi, mum. Whoops, sorry! Look out of the window. You can see the garden. Here's the bathroom. Oh, sorry dad.

Charlotte: Oh, that's the doorbell. Come and meet my friends.

Friends: Happy birthday!

Cameraman: Take it away.

Mum: Quiet, everyone! Now, blow out the candles, cut the cake, don't forget, make a wish!

All: One, two, three!

Russell: Surprise.

Charlotte: Mum!

Travelling

Victoria: Hi, mum. Hi, dad. My theatre group at school. They're all going to Australia.

Mum: Australia!

Dad: I think that's marvellous, darling.

Victoria: I've got some brochures here and my teacher told me to get some more information.

Mum: What is the trip? Where are you going?

Victoria: We're going to Sydney and we're going on a special trip to Ayers Rock.

Dad: But we'll go to the travel agent's tomorrow.

Mum: And we'll have to go to the bank and find out about currency.

Victoria: Please let me go!

Dad: I think we should find out a little more about it.

Victoria: Yes!
It's got the sea, beaches, shops...everything. This travel agent's organising the trip.

Victoria: Hi.

Assistant: Hi. How can I help you?

Victoria: I'm going to Australia on a school trip.

Assistant: Oh, yes.

Victoria: Where will I stay?

Assistant: Well, in Sydney you're staying at a hotel by The Rocks which is right in the centre of the city. Then you're flying up to Ayers Rock and staying in a hotel with a good view of the rock.

Victoria: Cool!

Mum: Is the accommodation full board or half board?

Assistant: It's half board, that's breakfast and evening dinner, because she'll have lunch while she's out on tour.

Mum: Will she need a vaccination?

Assistant: None needed for Australia.

Victoria: And what's the local currency?

Assistant: It's Australian dollars and you can get those and the traveller's cheques at the bank.

Victoria: Brilliant. OK, then. Well, thanks a lot.

Assistant: All right. Have a lovely time.

Victoria: I will. Bye.

Assistant: Bye.

Victoria: There's so much to organise before you go on holiday. Better not forget my passport or the currency. After all, that's what we're here for. Hi, can I order some Australian dollars, please?

Assistant: Sure, how much do you want?

Victoria: About two hundred and fifty pounds.

Assistant: Two hundred and fifty pounds. That's six hundred and twelve Australian dollars.

Victoria: OK.

Assistant: How would you like the money?

Victoria: Could I have two hundred pounds and fifty pounds in cash?

Assistant: Could you just sign here, please?

Dad: I think I'd better do that.

Victoria: Thank you.



Unusual Hobbies

Shima: Unusual hobbies. Most people collect something at some time or another. These three are video enthusiasts but they don't collect videos, they make them. This video's a James Bond film. It's in a supermarket car park. Come in. It's open.

Agent 1: I knew that.

Agent 2: I knew that.

Agent 3: They knew that.

Shima: What are you called?

Agents: The Agents.

Agent: Well, we usually make the films during our free time and when we're not at school and doing our part-time jobs.

Shima: How do they get the equipment?

Agent 3: We borrow the cameras off our parents and we edit it at school.

Shima: Films are expensive to make. How do they get the money?

Agent 1: We save our pocket money.

Sara: I like horse-riding, music, I love music. I also love athletics and most sports, really.

Yossie: Yeah, I like water-skiing, skiing, snowboarding, lots of extreme sports.

Crystal: I like reading, I like listening to music a lot and usually rollerblading.

Melissa: I like music, I like swimming and going shopping.

Susie: My interests are walking the dog and skiing.

Zoe: I like snowboarding and playing with my cats.

Pete: I really like photography and fly fishing.

Bubba: I collect hats. And I've got all kinds.

Barry: I collect coins. I started collecting and I've never stopped.

Bubba: This is my Jamaican hat here. A Jamaican friend of mine gave it to me.

Barry: The thing I like about coins is that it's, it's holding history in your hand. For example, this coin is from the time of Elizabeth the First.

Sarah: I started collecting about thirteen years ago. I decided to collect just because I liked it.

Barry: I think coin collecting's important now because in a few years time in Europe we're all going to be using Euros.

Life at Home

Dumani: Hi, come and join us. We talk about life at home, family and everything.

Victoria: So Tom, what did you do at the weekend?

Tom: Well, on Sunday night I went with all my friends down to the Marina.

Dad: Hello, darling. Have you had a nice day?

Victoria: Uh, uh. Dad, can I borrow ten pounds?

Dad: Why? You've had your pocket money for this week.

Victoria: I know but Tom's asked me to go bowling with him and his friends tonight.

Dad: But it's a school night. Haven't you got work for tomorrow?

Victoria: Yeah. I've got an essay but I've done it. Oh, please, dad. You know I won't be late.

Dad: But what's happened to your pocket money?

Victoria: I had to pay for the tickets for the school concert. And they were five pounds each.

Dad: (Sighs). OK. Just this once.

Victoria: Thanks, dad.

Dad: But I want you home for ten thirty.

Victoria: Hm, hm.

Dad: And if you're up late for school tomorrow...

Victoria: OK.

Dad: You're grounded for the weekend, OK?

Victoria: Yep.

Dad: Where are you going bowling?

Victoria: The Marina.

Dad: Well, you'll be finished late. So if you want to phone me from the Marina, I'll come and pick you up in the car.

Victoria: Thanks, dad. See you later.

Dad: Have a nice time.

Victoria: How late can you stay out?

Suresh: I can stay out until about eleven o'clock.

Georgina: I can stay out as long as I want but I have to tell my mum when I'm coming back.

Zoe: I can stay out until ten o'clock.

Harbanz: I can stay out as late as I want as long as I tell my mum where I am.

Victoria: What's the right amount of pocket money?

Harbanz: Ten pounds a week.

Diana: The right amount of pocket money is about fifteen pounds a week.

Zoe: I get ten pounds pocket money per week.

Suresh: I think the right amount of pocket money is about sixty pounds a month.

Georgina: I think the right amount of pocket money is about five pounds a week.

Victoria: What jobs do you do around the house?

Zoe: I do the cooking and the gardening.

Suresh: I wash the car and I help my mum with the dishes.

Georgina: At the weekends I do the washing up and I Hoover up the house.

Harbanz: I clean my room and I help my mum with the dishes.

Diana: I don't do any jobs around the house because I'm lazy.

Victoria: How do you get on with your family?

Suresh: I get on well with my dad and mum but not very well with my sister.



Georgina: I get on very well with my mother and my father but my grandparents I don't see very often.

Harbantz: I get on with my family very well but not with my little sister much.

Diana: I get on with my family quite well but especially my dad.

Zoe: I get on really well with my family.

Victoria: So how's your brother?

Tom: Well, he's very angry with me at the moment.

Victoria: Why?

Tom: Because I keep stealing all his clothes. Like this top.

Victoria: It's nice.

Tom: Thank you.

Pets and vets

Victoria: Hello. This is Billy. That's the vet's surgery.

Mrs. Turner: Thank you.

Vet: You're welcome.

Mrs. Turner: Come on.

Vet: Bye, bye, Gel.

Kate: Good bye, Mrs. Turner.

Mrs. Turner: Goodbye, Kate.

Kate: OK, Victoria and Billy. The vet will see you now.

Victoria: Thanks. Hi.

Vet: Hi, Victoria. Hi, Billy.

Victoria: What breed is your pet?

Patrick: My pet is a Dalmatian.

Victoria: What's special about your pet?

Patrick: My pet's special because she's full of fun and she has one brown spot.

Mrs. Turner: My pet is special because he is loved by everybody.

Victoria: Where did you get him or her from?

Patrick: She was abandoned and I got her from a vet.

Victoria: What do you like about him or her?

Patrick: I like her because I had a Dalmatian when I was a child and they're great fun.

Mrs. Turner: I like him because he keeps me company.

Victoria: What does he or she eat?

Patrick: She eats dried food.

Mrs. Turner: Tinned food and everything he can find.

Victoria: How do you exercise your pet?

Patrick: We go for long walks in the country.

Mrs. Turner: I go into my local park.

Vet: Come in, Victoria. Let's have a look at Bill. Hello, Billy. I haven't seen you for a while. Come out. Here we go. He looks terrific. He feels fine. Let's have a look at his teeth. They look just fine.

Victoria: Thanks a lot.

Vet: You're welcome. See you next time.

Victoria: Bye bye.

Best friends

Dumani: Hi. My name's Dumani and I've come down to Brighton to see my best friend, Sean.

Sean: Hi, my name is Sean. I like Dumani because we have a lot in common.

Victoria: Who's your best friend?

Pete: My best friend is called Rosita. We've known each other for twenty years.

Victoria: What's she like?

Yossie: Sara is very loud and very bossy.

Crystal: She's very amusing. She's good to be around and she's a laugh.

Melissa: I think she's really great. I can tell her everything and she's a really good person.

Susie: She's very beautiful and very kind and funny.

Zoe: She's generous and compassionate and a loving person.

Sara: Yossie is very loud. She's always running around and making trouble.

Pete: She's literally brilliant.

Victoria: What do you like doing together?

Zoe: We like shopping and playing Monopoly.

Sara: I like going to London, going clubbing there, just spending time with my friends, talking.

Melissa: Yeah. I like going up to London and we all go out together and have a good time.

Crystal: We go to the cinema a lot. We go and see films, we go down the beach quite a lot.

Melissa: We do a lot of shopping together as well.

Pete: We play together all the time and she's a good travelling companion and we do a lot of entertaining.

Susie: We like gardening together and cooking sometimes.

Victoria: Hi. This is Shima. She's my new friend. We go to the same school. We met at the bus stop. And she knows everybody.

Shima: No, I don't.

Victoria: Oh, you know Dumani and Sean, don't you?

Shima: Yeah, Dumani and Sean are really good friends of mine. Sean's a brilliant skater.

Victoria: What do you hate about each other?

Sara: Yossie always wakes up too early in the mornings.

Yossie: Sara laughs too much.

Crystal: The bit I hate about Melissa is that sometimes she can't keep a secret. She has to tell somebody else.

Pete: I really hate it when she sings out of tune.

Victoria: What makes a good friend?

Zoe: I think a good friend is someone who's good to themselves as well as being good to you.

Pete: A good friend is loyal.



Real Kids Answers

Page 27

1

Student's own answers

2

- 1 Chemistry, French
- 2 French, English, Art
- 3 Maths, English, Science, History
- 4 French, History, Maths, Science
- 5 Art, Science, History

3

- 1 quarter to eight
- 2 uniform
- 3 homework
- 4 jumper; trousers; shoes
- 5 Chemistry; Art
- 6 Sir; Miss

4

Student's own answers

Page 28

1

Student's own answers

2

- 1 False
- 2 True
- 3 False
- 4 True
- 5 True
- 6 False

3

- 1 bag
- 2 jacket
- 3 suits
- 4 top
- 5 favourite

4

Student's own answers

Page 29

1

Student's own answers

2

- 1 a printer
- 2 Russell
- 3 playing video games / on the playstation
- 4 a garden
- 5 Charlotte's friends

3

- 1 birthday cards
- 2 semi-detached
- 3 bungalow
- 4 satellite TV
- 5 upstairs
- 6 doorbell

4

Student's own answers

Page 30

1

Student's own answers

- 1 False
- 2 True
- 3 False
- 4 False
- 5 True
- 6 False

2

- 1 going
- 2 tomorrow
- 3 everything
- 4 centre
- 5 time
- 6 want

3

Student's own answers



Page 31

1

Student's own answers

2

- 1 They make films.
- 2 They save their pocket money.
- 3 horse-riding, water-skiing, skiing, snowboarding
- 4 They both like music.
- 5 Yes, they do.
- 6 He likes photography and fly fishing.

3

- 1 car park
- 2 make
- 3 free time
- 4 hat
- 5 history
- 6 years ago

4

Student's own answers

Page 32

1

Student's own answers

2

- 1 4
- 2 7
- 3 2
- 4 5
- 5 6
- 6 1
- 7 3

3

- 1 She wants to go bowling.
- 2 She paid for tickets for the school concert.
- 3 At ten thirty.
- 4 He can stay out as late as he wants.
- 5 Five pounds a week.
- 6 She does the cooking and the gardening.
- 7 He gets on with his mum and dad.

4

Student's own answers

Page 33

1

Student's own answers

2

- 1 True
- 2 True
- 3 False
- 4 False
- 5 False
- 6 True
- 7 False

3

- 1 special
- 2 get
- 3 like
- 4 company
- 5 food
- 6 walks

4

Student's own answers

Page 34

1

amusing; bossy; kind; funny; generous; loving

2

- 1 like
- 2 twenty
- 3 bossy
- 4 beautiful
- 5 London
- 6 sometimes
- 7 skater
- 8 bad

3

- 1 around
- 2 generous
- 3 shopping
- 4 together
- 5 quite
- 6 bus stop
- 7 wakes up
- 8 loyal

4

Student's own answers





Richmond Primary Reader



* The Rock Pool

Teacher's Notes	42
Worksheet 1	44
Worksheet 2	45
Worksheet 3	46



www.yoquieroaprobar.es





The Rock Pool

Before you read

Say: *Let's talk about Australia!* Show the class the cover of the book and explain that it's about a boy called Simon who lives in Australia. Display a map or globe and ask a volunteer to come and point out Australia. Ask the class questions to elicit what they know about Australia: What's the capital city? (Canberra); What languages do people speak in Australia? (English is the first language but there are also lots of people who speak Chinese, Italian and Greek); What animals live in Australia? (Kangaroos, Koalas and Duck-billed platypus are all native to Australia. It's also common to farm sheep and cows); What's the climate like? (There are different biomes including desert, rainforest and grassland).

While you read

Ask the children to stop reading on pages 10 and 11. Ask them to say how they think Simon is feeling and then ask them to say what they would do if they saw a shark this close. Ask the children if they've had any scary experiences like this and invite them to tell the class.

After you read

Write Simon on the board in a circle and draw four arrows coming from the circle. At the end of each arrow, write a title: school, hobbies, family, home. Point to school and elicit information about Simon: He doesn't go to school, he studies at home and talks to his teacher with a webcam. Then ask the children to look back at the story in pairs and make notes about Simon for the other titles.

Using the worksheets

Worksheet 1

Look at the story and solve the puzzle.

Explain that the crossword is all about the Rock Pool story. Write the clue for 3 across on the board: Simon's website is about _ _ _ _ _ animals. Ask the children to suggest how to complete the clue (ocean), then tell them to complete the crossword looking back at the story when necessary.

Worksheet 2

Find the letters and discover what's in Simon's bucket.

Tell the children that Simon's got an animal in his bucket and that they're going to do a puzzle to find out what it is. Write the first clue on the board:

The first letter is in _____ and in _____.

Elicit the two missing words (crab and waves) and ask the class to look at the words and say which letter they have in common (a). Then tell them to write the letter a on the first line in Simon's speech bubble. Ask children to solve the remaining clues to reveal the mystery animal.

Worksheet 3

Take the ocean animals quiz!

Give out the quiz, write the following key vocabulary on the board and check children's understanding: whale, heart, octopus, blood, brain, backwards. Then instruct them to look at the questions in pairs but mark their answers individually. Explain that the aim of the quiz is to learn new things about ocean animals and they should make a guess when they don't know an answer. Then go through each question

and tell the children the answers. Tell children to count how many answers they had right and see if they had more or less than their partner.

Extension

Play a game: divide the class into groups and give each group a sheet of paper. Give the groups a minute to make a list of all the sea animals they can think of in English. Stop the groups after a minute and give them a point for each word on their list. Continue the game with other categories: technology words, farm animals, countries and so on.



The Rock Pool Answers

Answers

Worksheet 1

Look at the story and solve the puzzle.

Across:

- 3 ocean
- 4 six
- 5 Mexico
- 8 summer
- 10 webcam
- 11 satellite

Down:

- 1 helicopter
- 2 eleven
- 6 Pacific
- 7 stomach
- 9 expert

Worksheet 2

Find the letters and discover what's in Simon's bucket.

It's an anemone.

Worksheet 3

Take the ocean animals quiz.

- 1 No, they haven't got eyelids.
- 2 30 metres
- 3 True
- 4 Yes, they've got a small eye at the end of each arm.
- 5 False, dolphins have got 2 very small ears just behind their eyes.
- 6 Blue
- 7 False, jellyfish haven't got brains.
- 8 No, they need to move constantly to breathe.
- 9 True, their hearts are the size of a small car.
- 10 True
- 11 Crabs have got 10 legs, 2 of them are claws.
- 12 Yes, they can change colour in just a few seconds to camouflage themselves.



The Rock Pool

Name: _____ Class: _____

Look at the story and solve the puzzle.

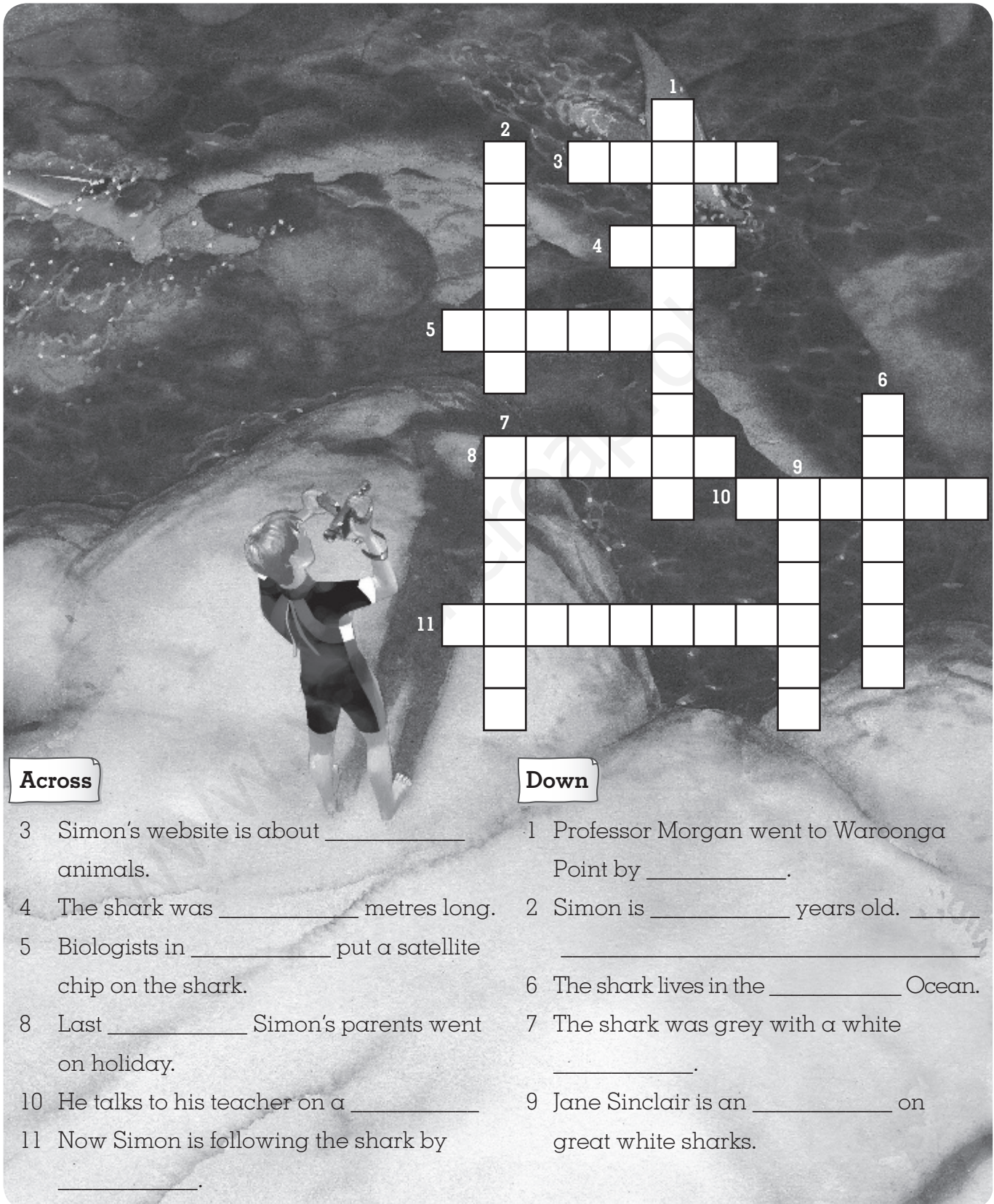

Across

- 3 Simon's website is about _____ animals.
- 4 The shark was _____ metres long.
- 5 Biologists in _____ put a satellite chip on the shark.
- 8 Last _____ Simon's parents went on holiday.
- 10 He talks to his teacher on a _____
- 11 Now Simon is following the shark by _____.

Down

- 1 Professor Morgan went to Waroonga Point by _____.
- 2 Simon is _____ years old. _____
- 6 The shark lives in the _____ Ocean.
- 7 The shark was grey with a white _____.
- 9 Jane Sinclair is an _____ on great white sharks.



The Rock Pool

Name: _____ Class: _____

Find the letters and discover what's in Simon's bucket.

The first letter is in



_____ and in



The second letter is in



_____ and in



The third letter is in



_____ and in

8

The fourth letter is in



_____ and in



The fifth letter is in



_____ and in



The sixth letter is in

90

_____ and in



The seventh letter is in



_____ and in



What's in my bucket?



It's an _____.



The Rock Pool

Name: _____ Class: _____

Take the ocean animals quiz!

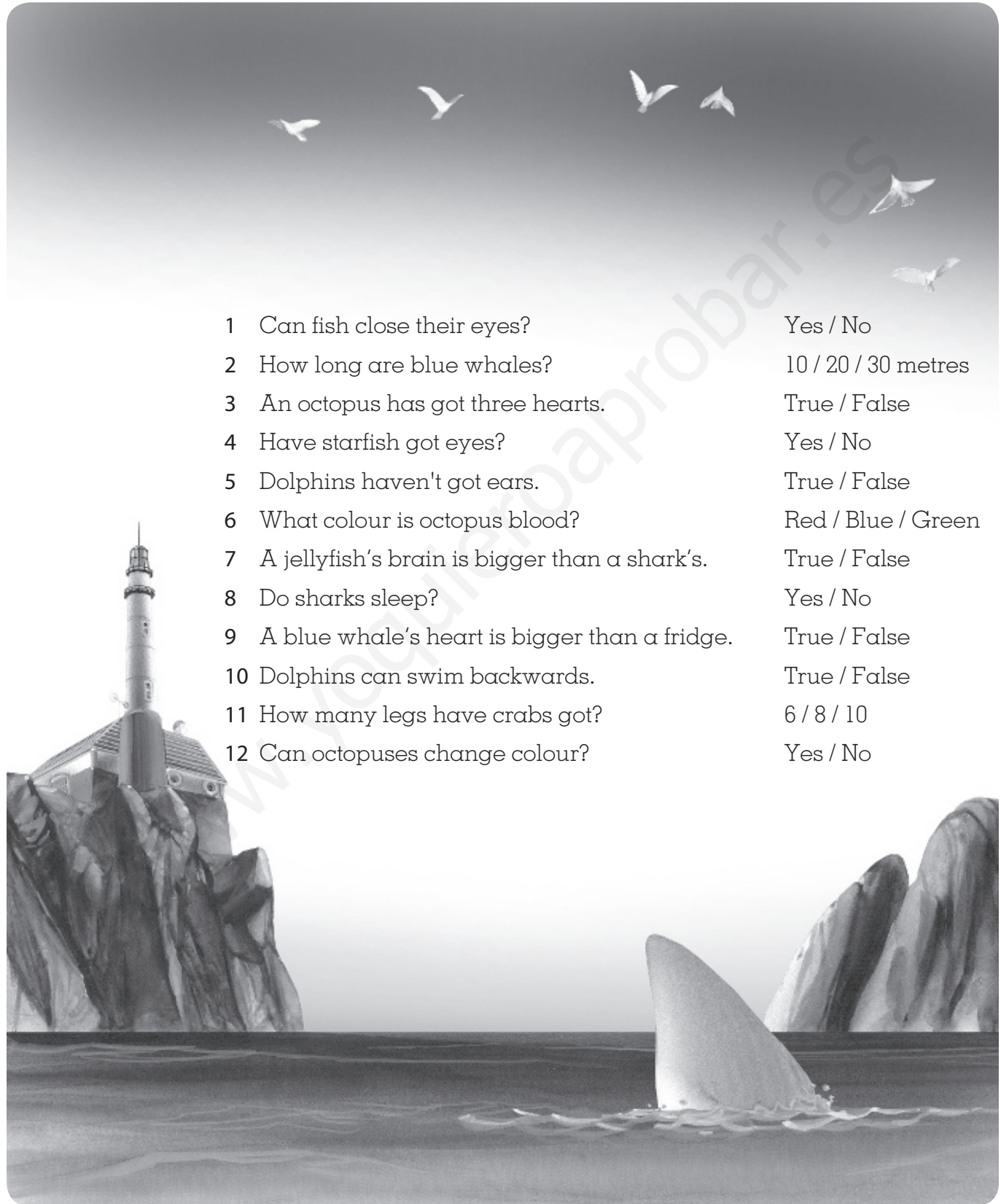

- | | |
|---|---------------------|
| 1 Can fish close their eyes? | Yes / No |
| 2 How long are blue whales? | 10 / 20 / 30 metres |
| 3 An octopus has got three hearts. | True / False |
| 4 Have starfish got eyes? | Yes / No |
| 5 Dolphins haven't got ears. | True / False |
| 6 What colour is octopus blood? | Red / Blue / Green |
| 7 A jellyfish's brain is bigger than a shark's. | True / False |
| 8 Do sharks sleep? | Yes / No |
| 9 A blue whale's heart is bigger than a fridge. | True / False |
| 10 Dolphins can swim backwards. | True / False |
| 11 How many legs have crabs got? | 6 / 8 / 10 |
| 12 Can octopuses change colour? | Yes / No |



Reading Worksheets



Reading Worksheets

Reading 1	48
Reading 2	49
Reading 3	50
Reading 4	51
Reading 5	52
Reading 6	53
Reading 7	54
Reading 8	55
Reading 9	56
Answers	57



www.yoquieroaprobar.es





Name: _____ Class: _____

Read and underline Bear's achievements.

Bear Grylls, a famous adventurer

Bear Grylls is a famous adventurer who knows a lot about nature and survival. He was born on 7th June, 1974, on the Isle of Wight in Great Britain. (His name was Edward Michael Grylls, but he officially changed it to Bear; his school nickname, later on.) As a child, he often went mountain climbing with his dad.

Bear has got an impressive list of achievements. He has received a black belt in karate. He has written four books about survival, and he has starred in a number of educational TV programmes. He has also had TV interviews with Oprah Winfrey, David Letterman and Jay Leno. In addition, he has organized several events to raise money for children's charities around the world, including having a dinner party high in the air on a hot-air balloon.

Bear Grylls started his career in the British army. He learned how to fight without weapons and

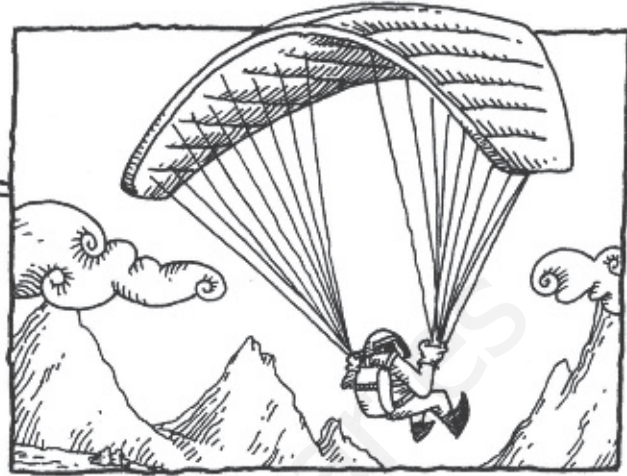

how to survive in the wild. Unfortunately, he had a terrible parachuting accident in Africa. His parachute didn't open, and he broke his back in three places. It took a long time for him to recover, but he never forgot his dream to climb Mount Everest.

He soon realized his dream. In 1998, he became the youngest British person ever to climb Mount Everest. And in 2007 he flew a paraglider over Mount Everest! He used the experience to earn money for charities.

Bear is married to author Shara Grylls, and they've got two sons, Jesse and Marmaduke.

⚓ Circle *True* or *False*.

- | | | |
|---|------|-------|
| 1. Bear's mum and dad named him Edward. | True | False |
| 2. He writes books about karate. | True | False |
| 3. Bear raises lots of money to save the environment. | True | False |
| 4. He broke his back in a mountain climbing accident. | True | False |
| 5. He climbed Mount Everest when he was 24 years old. | True | False |
| 6. He flew over Mount Everest in a helicopter. | True | False |

⚓ Correct the false sentences.



Name: _____ Class: _____

Read and number the paragraphs.

1 Growing popularity

2 Films without sound

3 The modern film

4 The film is born

5 Optical toys

6 Advances in photography

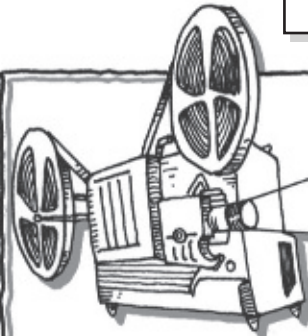

The history of films

We all love films, but did you know that the concept of the motion picture has been around for almost two thousand years?

With their invention, the *cinématographe*, the Lumière brothers created several very short films that amazed audiences. In 1897 Paris became the home of the first permanent cinema, and two years later Georges Méliès created the first science fiction film. It was about a trip to the moon, and it lasted 14 minutes.

Around the same time, photography was developing. In 1869 scientists invented a kind of film that could save series of moving photos inside a camera. In 1895 Louis and Auguste Lumière invented the *cinématographe*, a portable camera that could also be used to process and project film.

The United States' film industry was beginning to grow, and people began to build small cinemas, called nickelodeons. They were very popular, and by 1908 there were eight thousand of them in U.S. cities.

Films became popular immediately, and soon companies were producing 90-minute films. They were called silent films because there was no way to record the sound of the actors. They weren't completely silent, though. They usually had recorded or live music in the background.

By the 1920s, the film studios began making films in Hollywood, California. They soon developed ways of recording actors' voices and the modern film was born. These films were called *talkies*. They also began making films in colour, which was very expensive at that time. The 1930s brought in "The Golden Age of Hollywood," with mass production of films, including musicals and animated films, that we still watch today.

The first moving-picture device was the zoetrope, invented by Ting Huan in China around 180 AD. It was a cylinder with paintings inside. By spinning the cylinder, you could see the illusion that paintings were moving. The idea, however, was mostly forgotten until the nineteenth century, when many inventors began experimenting with optical toys using small drawings and paintings.



Name: _____ Class: _____

Read and complete the list.

Dear Miss. Green,
 I like to watch wild animals on TV, and see how they live. I think the problems with pollution are terrible. But the problems with the environment are caused by people who run factories and pour chemicals into the rivers, right? I don't do those things, so what can I do to help the environment?
 Sincerely,
 Wants-2-Help



Dear Wants-2-Help,
 It is true that some people create lots of pollution for everybody else. However, making small changes with the way we do things every day can really help the environment. When your family goes to the supermarket, take your own bag. That way you won't need plastic bags to carry the things that you buy. When you do get plastic bags, reuse them. Did you know that in New Delhi, India, plastic bags are prohibited? People throw them in the streets and they go into the drains. When there is heavy rain, the water can't escape and it floods the city. Another thing you can do is to fill a plastic bottle with water and put it in the back of your toilet. It uses less water that way. And

remember to have short showers, too. When you are outside, be careful not to leave any litter on the ground. It is easy to drop rubbish in the street, but if everybody does it, the street will look like a landfill! That includes when your dog goes to the toilet, too. Finally, investigate ways to protect nature, and clean up the environment in your community. You might find a volunteer group that picks up litter, collects materials to recycle or plants trees. You could even start your own! Remember, you don't have to fly to Antarctica or the Amazon and make changes there. You can do a lot to help the Earth where you live. Hope this helps,
 Miss Green

How I can help

Hand-drawn box with a scalloped border containing three horizontal lines for writing.

⚓ Circle the correct option.

- Who causes environmental problems?
 - Other people.
 - Everybody.
- What is Miss. Green's main point?
 - You shouldn't use plastic bags.
 - Everyone can help the environment.
- Which tip does Miss. Green NOT give?
 - To recycle batteries.
 - To clean up after one's pet.



Reading 5

Name: _____ Class: _____

Read and colour the texts with the corresponding colour.



Imagine the scene: a painter with her easel. The painter stops to think. Then she chooses a bright colour and makes a long, vibrant line across the canvas. It's a masterpiece! But did you imagine that the painter was an Asian elephant named Ramona? Ramona is a female elephant from Indonesia. Her mum was part of a circus for tourists, and her dad was a wild elephant. When she was four years old, some artists visited Ramona, and taught her to paint. She learned to use a paintbrush with her trunk, and add different colours of paint to the canvas. In Indonesia and around the world, elephants were often used like trucks to carry people and heavy objects. People didn't always treat them well, and at the same time, they destroyed their environments in the wild. Now artists like Ramona are helping to protect this land and promote good treatment of elephants. Their work has been sold at famous galleries in New York. But elephants aren't the

only animals that can paint. There are paintings by dogs, ponies, turtles and even dolphins. The "Doggie Da Vincis" are a group of service dogs that help people with disabilities. They are incredibly intelligent, and when there wasn't enough money to continue their service dog programme, they went to work. They learned how to paint, and the money from their artwork pays for their training. You can watch videos of them, or buy note cards of their paintings, online. Finally, there's Buddy the pony. He's got a serious disease called equine cushing's disease. Doctors and veterinarians don't know that much about this disease. Buddy's paintings help to pay for his treatment and research so that other horses and ponies with the disease will have a better chance of good care. You can learn more about him at www.thepaintingpony.com.



elephant	red
dogs	blue
pony	yellow



I want to help other animals with my disease.

My environment is in danger.

We help people with disabilities.

Some artists taught me to paint.

Sometimes I don't feel well.

You can watch us paint online.



Reading 6

Name: _____ Class: _____

Read and complete the sentences.

Lance Armstrong was born on 18th September, 1971, in the USA. His name at that time was Lance Edward Gunderson. His parents, Linda Walling and Eddie Gunderson, named him after a football player, Lance Rentzel. His father left the family when Lance was two years old, and his mother married Terry Armstrong, who adopted Lance and gave him his last name.

As a child, Lance loved sport and began competing in triathlons when he was 12 years old. (A triathlon is a sporting event where you have to swim, ride a bike and run as part of a race.) Lance Armstrong became a professional athlete in 1987, when he was only 16 years old.

He participated in many events and did especially well with biking (or cycling) events. In 1993 he was the highest-ranking cyclist in the world. In 1995 and 1996, Lance Armstrong competed in many other races and won some, but he was not spectacular. He came 12th in the 1996 Olympic Games. Later that year, he was diagnosed with cancer. It was in many different parts of his body, and doctors did not expect him to survive. His treatment, however, was very effective, and he returned to racing in 1998.

By 2005, Lance Armstrong had seven consecutive victories in the famous Tour de

France. After that, he retired from cycling. In 2008 he announced his return to the sport to fight cancer around the world.

Lance Armstrong is a symbol for excellence in sports and strength in fighting cancer. Because of his own illness, he created the Lance Armstrong Foundation, with its motto LIVESTRONG®, to raise awareness about cancer and teach people that they can survive the disease. It also aims to teach people healthy habits so that with or without cancer, they can live well.

Lance currently lives in Texas and has got three children: Luke, and twin girls Isabelle and Grace.

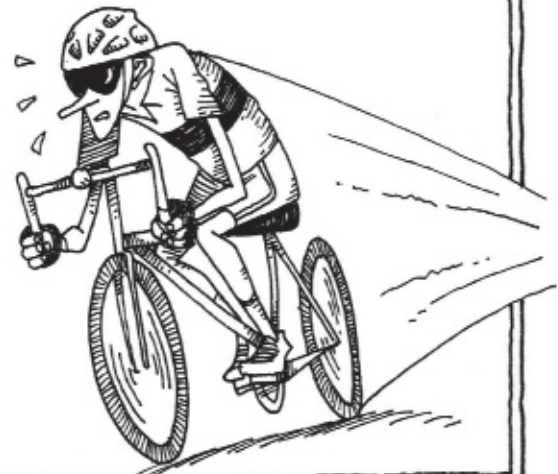

1. Lance Armstrong's father was _____.
2. Lance began his sporting career by competing in _____.
3. He _____ at 16 years old.
4. Later, Lance Armstrong competed in _____ events.
5. Doctors didn't expect Lance to survive because _____.
6. After his treatment, he _____ in 1998.
7. Lance is famous for winning _____ Tour de France titles.
8. The motto of the Lance Armstrong Foundation is _____.



Reading 7

Name: _____ Class: _____

Read and complete with the highlighted words.



We all know that a diet of chocolate bars and crisps will make you feel sick, and that it's important to eat enough fruit and vegetables. But have you thought about the things you drink?

When people think about healthy habits, many forget that drinking enough water is essential. Your body needs water more than any other substance - except air, of course!

Did you know that more than half of your body weight is water? It cleans your body's cells. It helps to maintain the balance of salt and other minerals in your body. It also keeps your skin and your internal organs healthy. When you drink water regularly, you feel better and will probably have fewer health problems. But the water in your body is constantly escaping. On a hot day, or after exercise, this water comes out of your skin when you sweat. You also lose water when you go to the toilet.

Because of this, you need to replenish your water supply regularly. That means drinking enough water

and other beverages during the day. Some of the water that your body needs comes from food, so you don't need to drink more than two litres of water.

But remember, when you're thirsty, it's much better to drink water than sugar- and caffeine-loaded fizzy drinks, or juice drinks have only got a small percentage of real juice in them.

When you don't consume enough water, your body can become dehydrated. That means it hasn't got enough water to function well. You might get a headache. Your mouth will feel dry, and you won't be able to eliminate the toxins in your cells. Dehydration is very dangerous, and if you become very dehydrated, you can get very ill or even die. However, you can also get very ill if you drink too much water: That's water intoxication which happens when you drink a large quantity of water.

Balance is important, and the key to good health. Drink one to two litres of water a day and you'll see the difference!

1. Having _____ drinks can make it hard to sleep at night.
2. _____ is a way to say not too much and not too little.
3. Some juice drinks have got a high _____ of sugar in them.
4. The water that your body can use is your water _____.
5. You should _____ the water in your system regularly.
6. Lots of _____ can collect in your body when you're dehydrated.
7. Be careful of _____. Too much of a good thing can be bad for you.

Write the definitions.

consume: _____

beverages: _____

sweat: _____

dehydrated: _____



Reading 8

Name: _____ Class: _____

Read and match.

1 A six-year-old boy took his parents' car for a drive to the supermarket yesterday. He was stopped by the police, who called his family. No one was hurt.

2 The local team won their match on Friday night, 7 to 0. Unfortunately, the star player was hurt and won't be able to play for two months. He was treated for a broken leg.

3 Scientists have created a robot that can brush your teeth for you. It was invented to help children learn good brushing techniques, and it was presented at the university science fair last week. You might be able to buy one early next year.

4 Four men were arrested today after they were caught stealing a rabbit sculpture from a local park. The sculpture was not damaged in the incident.

5 An award was given to a local firefighter who rescued a hamster. The hamster was saved from a terrible fire. It was later treated by the vet.

6 A spaceship was seen in the sky above the city last night by a pair of hikers. They said it had bright lights and moved slowly. After ten minutes, it disappeared. No other sightings were reported.

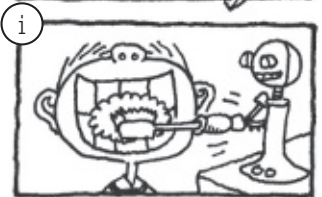
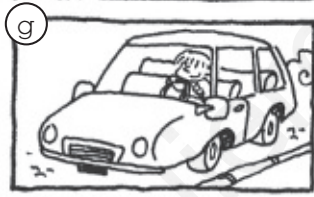
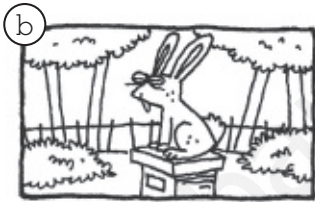

⚓ Write your own news story.

⚓ Draw.



Name: _____ Class: _____

Read and number the pictures.

A good neighbour

Jonathan Tillsbury is just a normal boy. He likes playing video games and going to the cinema. He goes to school every day and doesn't always get A's. But Jonathan is a hero.

Jonathan was walking home from school one day when he saw a robber attack a neighbour and take her bag. The woman fell down, and the robber ran away. He jumped into a car and disappeared.

Jonathan didn't panic. He immediately went to see if his neighbour was OK. "I was very scared," the woman said, "and I felt very vulnerable. But Jonathan took care of everything."

Jonathan called the police on his mobile phone. They sent an ambulance for the woman and came to ask him what happened. Jonathan described the robber and the car, and soon the police caught the man.

"Jonathan did exactly what he needed to do," said Sergeant Ritter. "In cases like this, the most important thing is to help the victim and call the police. And, of course, it was helpful that he remembered what happened so well. We caught the suspect, and now there's one less dangerous criminal on the streets."

Jonathan will be given an award this Saturday by the mayor.

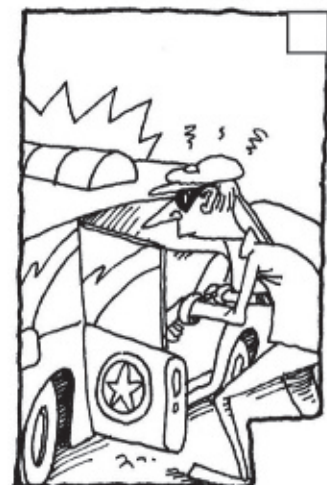
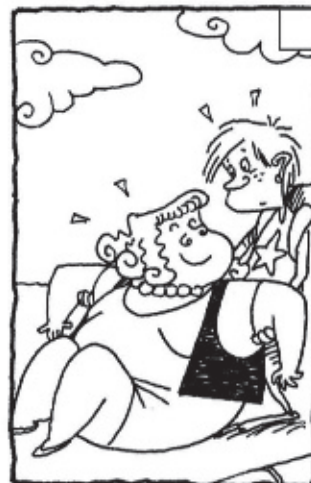



Reading Answers

Reading 1

received a black belt in karate;
written four books about survival;
starred in a number of educational
TV programmes;
had TV interviews with Oprah
Winfrey, David Letterman and
Jay Leno;
has organized several events
to raise money for children's
charities around the world

- 1 True
- 2 False
- 3 False
- 4 False
- 5 True
- 6 False

He writes books about survival.
He raises lots of money for
children's charities.
He broke his back in a
parachuting accident.
He flew over Mount Everest in a
paraglider.

Reading 2

- 1 sheet music
- 2 rhythm
- 3 blue notes
- 4 swing
- 5 spirituals
- 6 improvisation
- 7 emotions
- 8 double bass

Reading 3

- 3 2
- 5 4
- 6 1

Reading 4

(Any of the following:)
Take your own bag to the
supermarket.
Reuse plastic bags.
Put a bottle of water in the back of
the toilet.
Have short showers.
Don't leave litter on the ground.
Clean up after my dog.
Clean up the environment in my
community.

- 1 b
- 2 b
- 3 a

Reading 5

Yellow: I want to help other
animals with my disease.;
Sometimes I don't feel well.
Red: My environment is in
danger.; Some artists taught me
to paint.
Blue: We help people with
disabilities.; You can watch us
paint online.

Reading 6

- 1 Eddie Gunderson
- 2 triathlons
- 3 became a professional athlete
- 4 biking/cycling events
- 5 the cancer was in many parts of
his body
- 6 returned to racing
- 7 seven consecutive
- 8 LIVESTRONG

Reading 7

- 1 sugar- and caffeine-loaded
- 2 Balance
- 3 percentage
- 4 supply
- 5 replenish
- 6 toxins
- 7 water intoxication

(Possible answers)

consume: to eat or drink
something
beverages: drinks
sweat: water that comes out of
your skin when it's hot
dehydrated: when you don't have
enough water

Reading 8

- 1 d, g
- 2 f, k
- 3 i, l
- 4 b, c
- 5 e, h
- 6 a, j

Reading 9

Top row: 3, 1, 5
Bottom row: 7, 2, 4, 6



Review Games



* Leapfrog: Review units 1-3

How to play	60
Worksheet	61

* Word hive!: Review units 4-6

How to play	62
Worksheet	63

* Say or stay: Review units 7-9

How to play	64
Worksheet	65



www.yoquieroaprobar.es





Leapfrog

Review units 1-3

How to play

Divide the class into groups of four and have each student choose an object to mark his/her space during the game. Students take turns rolling a die and moving their object the corresponding number of spaces. When they land on a picture, they say the word. When they land on an instruction, they read it and do what it says. If they cannot do it correctly, they go back to the previous space. The first student on the Winner! space wins the game.

www.yoquieroaprobar.es



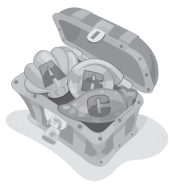

Leapfrog



Tell someone to sit in the shade. Explain why.



Make a sentence with *exhausting*.

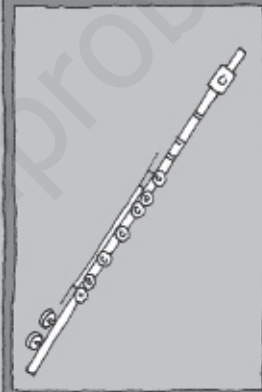

Make a true sentence about yourself with *already* and *yet*.



Ask someone if he / she has ever gone canoeing.



Ask a friend a question with *yet*.



Tell a friend to do something. Then report what you said.





WORD HIVE!

Review units 4-6

How to play

Divide the class into pairs. Players take turns choosing spaces and doing the language tasks – completing the words or unscrambling the sentences. When they do a task correctly, player 1 marks the space with a ✕ and player 2 marks it with a ✓. The player with the most spaces at the end is the winner.

www.yoquieroaprobar.es

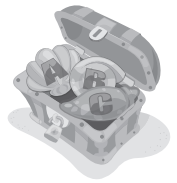

WORD HIVE!

A word search puzzle shaped like a beehive, with bees on each cell. The words are:

- use • rather • I'd • pastels
- sm _ _ _ e
- landf _ _ _ _
- bowling
- exh _ _ _ _ fumes
- mo _ _ _ _
- made • of • what • it • is
- le _ _ s
- Home
- r _ _ _ i
- house • that • a • is • artist • famous • where • lived • the
- forever • is • extinction
- di _ _ _ camera
- sew _ _ _ _
- li _ _ te _
- oil
- s _ _ _ _
- baseball
- baseball
- g _ _ _ _
- produced • in • tea • China • is
- golf
- c _ _ _ _
- puck
- el _ _ _ _
- ab _ _ _ ct
- tennis
- r _ _ _ _ o _ _ l
- made • in • it's • Italy
- p _ _ _ _



SAY OR STAY

Review units 7-9

How to play

Divide the class into groups of four and have each student choose an object to mark his/her space during the game. Students take turns rolling a die and moving their object the corresponding number of spaces. When they land on a space, they do the task or give the word or phrase that corresponds to the definition. If they cannot do it correctly, they go back to the previous space. The first student to get to the end and say three things he/she would do if he/she was the headteacher is the winner.

www.yoquieroaprobar.com



SAY OR STAY



START

Name something that helps you think.

Name something that helps you breathe.

Define **muscles**

Define **heart**

Name something that covers your whole body

Say when you hear the sound **achoo**.

Name something you do when you sleep.

Name something you do when you are bored.

Define **chew**.

Give an expression to find out what programme is next.

Give an expression that means **you decide**.

Define **courage**.

Define **honesty**.

Define **loyalty**.

Give an expression about changing the channel.

FINISH



Say 3 things you would do if you were the headteacher of your school!

Define **get even**.

Give an expression that means you are nervous.

Define **scratch**.

Name a programme that uses moving drawings

Name a programme about people and their lives.

Name a programme about world events

Say what will happen if you don't exercise.

Say what will happen if you don't sleep enough.

Give an expression that means something is expensive.



Tests



Tests

Diagnostic Test	68
Unit 1 Test	72
Unit 2 Test	75
Unit 3 Test	78
Unit 4 Test	81
Unit 5 Test	84
Unit 6 Test	87
Unit 7 Test	90
Unit 8 Test	93
Unit 9 Test	96
Answers	99



www.yoquieroaprobar.es





Diagnostic Test

Name: _____ Class: _____

1 Listen and number the people. 2.32

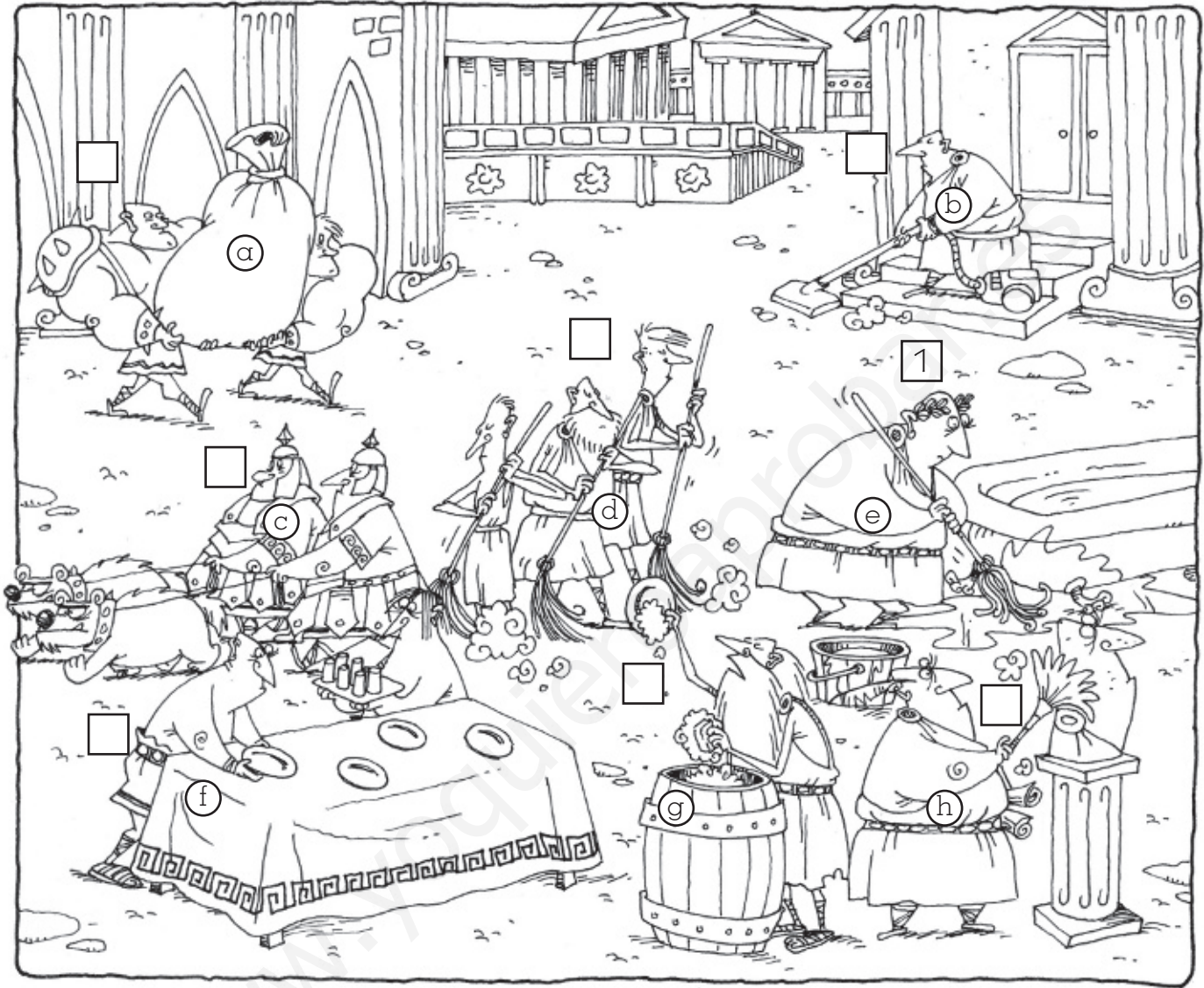

2 Listen again and complete the report. 2.32

1. He says _____ he has to mop the public bath _____.
2. They say _____.
3. _____
4. _____
5. _____
6. _____
7. _____
8. _____

3 Play a guessing game.

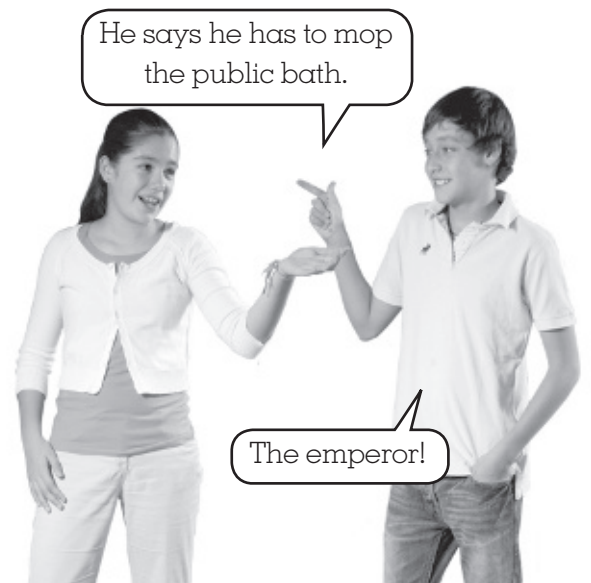

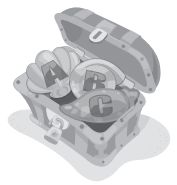

2 Look and write the captions.

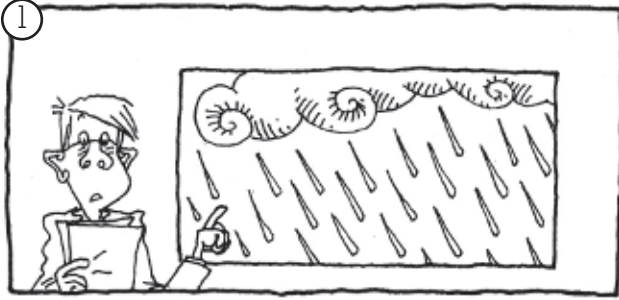

there be / a flood

There's going to be a flood.

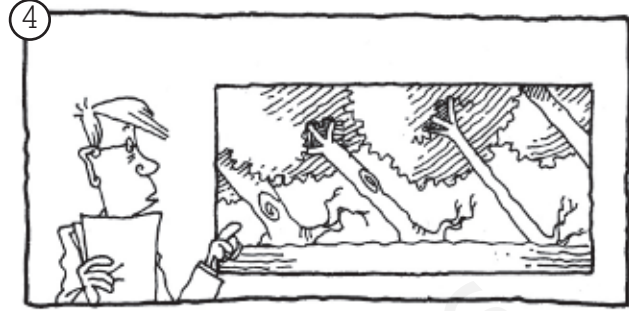

the trees / fall down

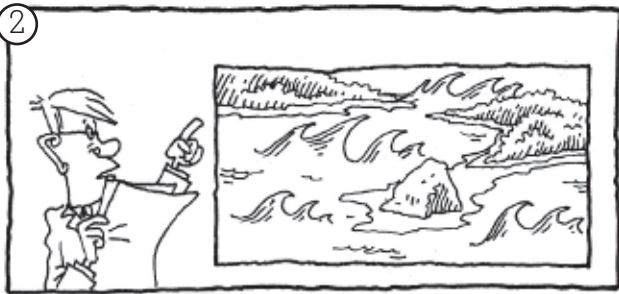

there not be / a tsunami

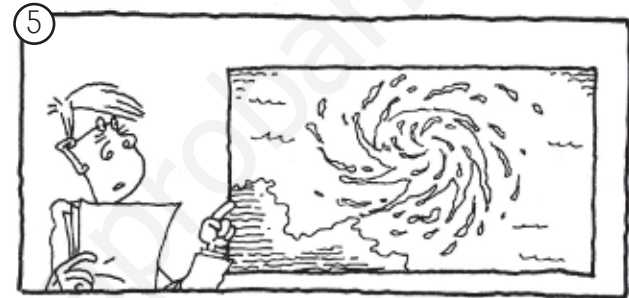

a hurricane / form

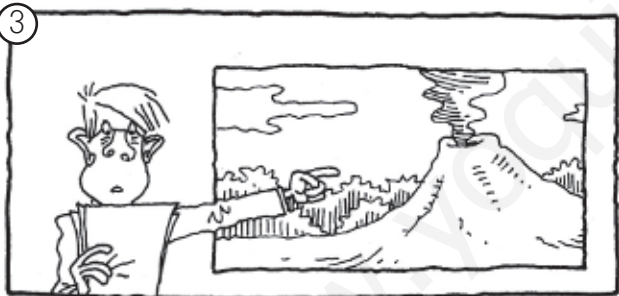

there be / an eruption

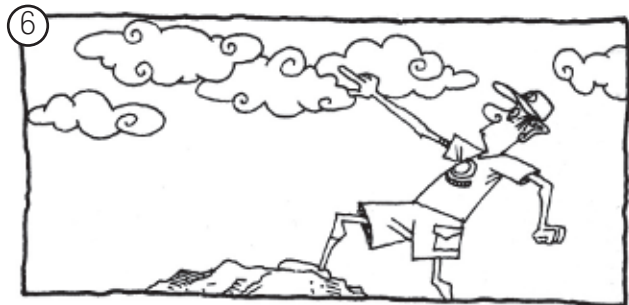

a tornado / not form

3 Listen and number the lines.  CD2 2.33

Chorus:

And it's just a little frightening!

Let's put it on TV

It's intense! It's exciting! 1

For everyone to see!

4 Listen again and sing the song.  CD2 2.33

We're chasing a tornado
With raging, violent winds.
It's more destructive and more powerful
Than any other storms!

Chorus

We're flying over a volcano
To see the eruption.
It's more dangerous and more extreme
Than anything we've seen!

Chorus



4 Listen and circle what will happen.  CD2 2.34



5 Listen again and complete the predictions.  CD2 2.34

1. There _____ will be light bulbs _____.
2. Children _____.
3. People _____.
4. Children _____.
5. Scientists _____.
6. Doctors _____.

6 Write your own predictions and draw.



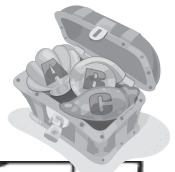

6 Read and number the pictures.

Break three eggs into a mixing bowl and add vanilla, sugar and butter. But before you do that, you have to chop some nuts. Then stir the mixture and add the nuts. After you add the nuts, pour it into a pie shell and bake it for an hour. Take it out of the oven. Before you serve it, put some chopped nuts and whipped cream on top.

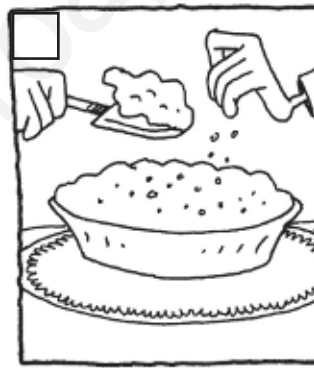
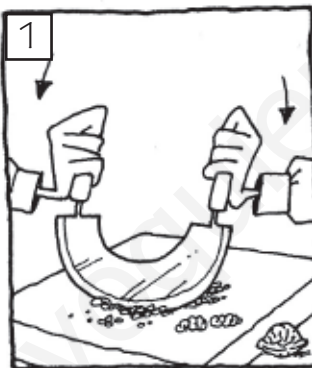
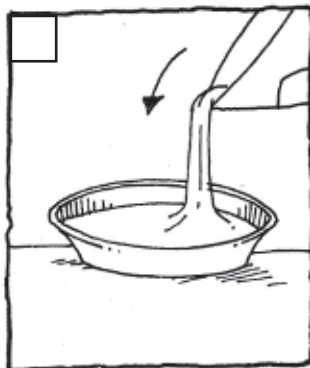
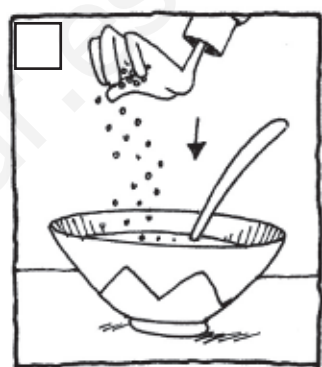
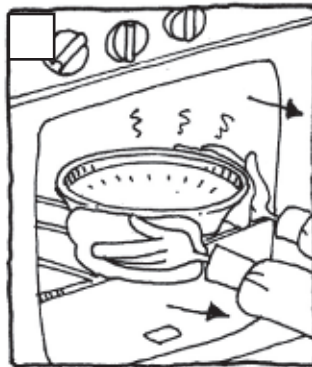
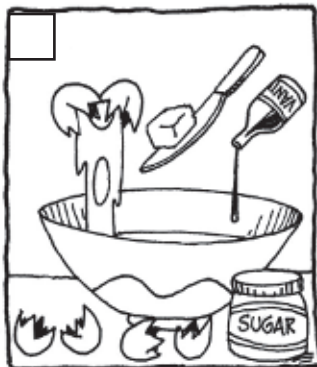
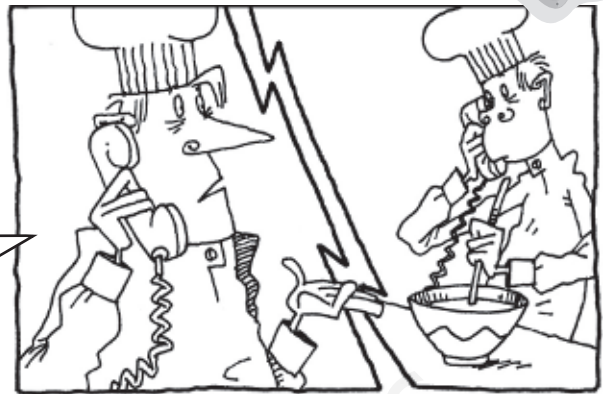

7 Unscramble the sentences.

1. bake · you · if · biscuits · long, · they · too · burn

If you bake biscuits too long, they burn.

2. sugar, · you · add · too · tastes · much · it · bad · if

3. you · if · freeze · stay · they · vegetables, · fresh

4. too · it · early, · if · taste · prepare · you · food · doesn't · good

5. healthier · you · meat, · it's · if · grill



Test 1

Name: _____ Class: _____

1 Complete the sentences.

- The survivors of the _____ shipwreck _____ swam to the beach.
- You can get _____ in the sun.
- She bought a _____ ring with a in it.
- He drank from a _____.
- People use dry sheets of _____ to make sushi.
- He climbed up a _____ to get a coconut.
- The sun is very hot. We should sit in the _____.
- Go scuba diving to see colourful _____ reefs.
- _____ look disgusting, but are delicious with lemon juice.

2 Circle the correct option.



rotten / fresh



rotten / fresh



smooth / rough



slimy / smooth



smooth / rough

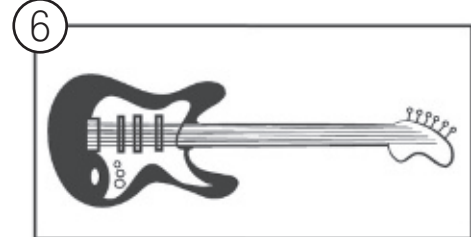

quiet / loud



crunchy / creamy



crunchy / creamy



beautiful / disgusting



Test 1

3 Complete the questions.

1. (eat) _____ Have you ever eaten _____ oysters?

No, I haven't. They look disgusting!

2. (climb) _____ a tree?

Yes, I have. Several times.

3. (go) _____ surfing?

No, I haven't.

4. (see) _____ a giraffe outside a zoo?

Yes, I have. In a safari park.

5. (touch) _____ a snake?

No way! Snakes are scary, and I don't like them.



4 Write sentences.

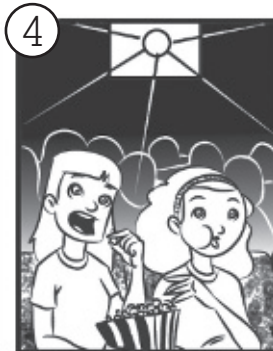
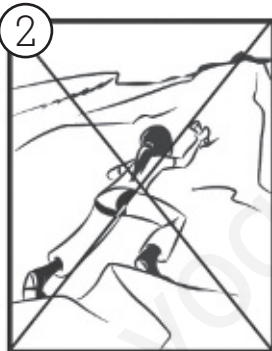

1. visit / France, Germany

He has visited France and Germany.

2. not climb / any volcanoes

3. not eat / snails

4. see / lots of films

5. read / two books



5 Read and draw the correct path.

Hi Jodie,
 I'm on holiday with my mum and dad.
 We're sailing in the Caribbean! We started
 in Puerto Rico and we sailed to the Virgin
 Islands. Next we visited Anguilla. We went
 scuba diving there and saw some amazing
 coral reefs. Last week, we stopped at
 Monserrat. It's beautiful, but there's a big
 volcano there that destroyed part of the
 island. There are still eruptions sometimes.
 Yesterday we arrived in Martinique. The
 people here speak French. The food is
 really different, but I like it. Tomorrow
 we're going to sail to Trinidad and Tobago.
 And next week we're going to an island
 that is very far away. It's called Aruba.
 Sometimes it's boring on the boat. There
 aren't many things to do.
 Mandy



⚓ Correct the sentences.

1. Jodie is sailing with her mum and dad.
 Mandy is sailing with her mum and dad.

2. They went scuba diving in the Virgin Islands.

3. A volcanic eruption destroyed part of Martinique.

4. There are still earthquakes in Monserrat.

5. The architecture in Martinique is really different.

6. She thinks that sometimes it's boring on land.



Name: _____ Class: _____

1 Label the instruments.



- | | | |
|------------------------|----------|----------|
| 1. _____ trumpet _____ | 4. _____ | 7. _____ |
| 2. _____ | 5. _____ | 8. _____ |
| 3. _____ | 6. _____ | 9. _____ |

2 Read and write the musical genre.

- | | |
|---|------------------|
| 1. It is also called rock 'n' roll. | _____ rock _____ |
| 2. It comes from the word <i>popular</i> . | _____ |
| 3. People often wear cowboy hats when they play it. | _____ |
| 4. Saxophone is important in this genre. | _____ |
| 5. It uses guitars and it's very loud. | _____ |
| 6. They dance it in Brazil during Carnival. | _____ |
| 7. Beethoven and Bach composed it. | _____ |



3 Look and write sentences.

Nick Stevens



	Yes	No
sing in public	✓	
win a Grammy		✓
record a CD		✓
be on TV	✓	
play with a pop star	✓	
travel to New York		✓

1. He has already sung in public. _____
2. _____
3. _____
4. _____
5. _____
6. _____

4 Complete the dialogue.



(win) Have you ever won
a competition?

(finish) _____

_____ your homework yet?

Oh no! I (buy) _____

_____ the tickets yet.

(use) _____

_____ an MP3 player yet?



Yes, I have. I won one last year. They
(give) _____ gave _____ me a trophy.

Yes, I have. I (do) _____
_____ it two hours ago.

Don't worry. I (buy) _____
_____ them yesterday.

Yes, I (get) _____
_____ one for my birthday.



Test 3

3 Complete with object pronouns.

1 I like **your new sunglasses**.
Where did you get them?

They were on sale at the sports shop.

2 I can't find **my dictionary**.
I think Mary was using _____.

3 I think **Madonna** is a great singer.
I don't like _____ very
much. I prefer jazz music.

4 Have you met **the new boy** in class?

No, I haven't met _____
yet. Is he good-looking?

5 **We're** going to the cinema. Do you
want to come with _____?

6 I don't like **spiders**. I'm
afraid of _____.

4 Report the sentences.

1. Sit down, Bob and Peter.

She told them to sit down.

2. Look at the poster, Ann.

3. Don't use a pen, Gina.

4. Mark, don't open the window.

5. Mike, turn off the mobile phone.

6. Carl and Sue, listen carefully.

7. Lisa, write the answer on the board.





5 Read and write the names.

This week's film review:

MAMMA MIA!

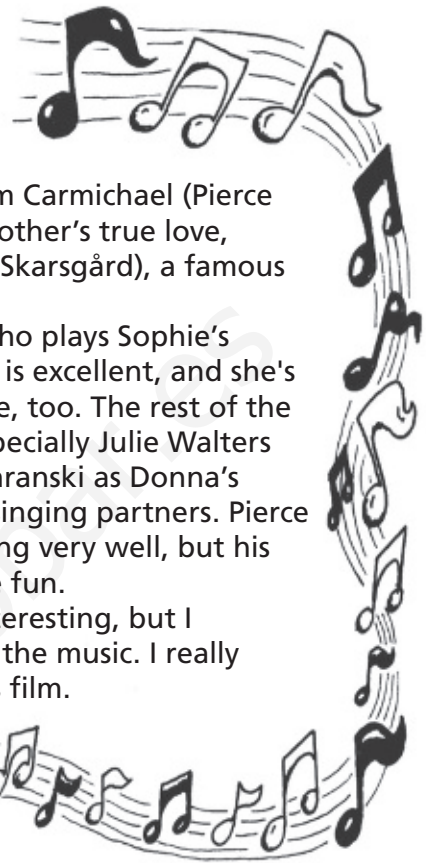
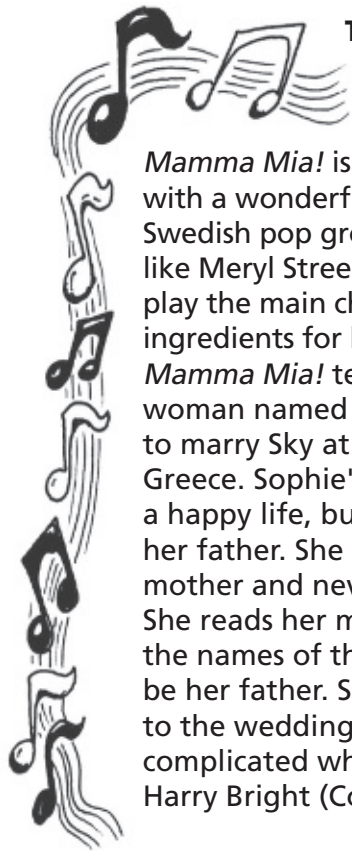

Mamma Mia! is a musical comedy with a wonderful soundtrack from the Swedish pop group ABBA. Top stars like Meryl Streep and Pierce Brosnan play the main characters. It's got all the ingredients for being a great success. *Mamma Mia!* tells the story of a young woman named Sophie. She's planning to marry Sky at her mother's hotel in Greece. Sophie's got good friends and a happy life, but one thing is missing: her father. She grew up with her mother and never met her father. She reads her mother's diary and finds the names of three men who might be her father. She invites all of them to the wedding. Things become very complicated when the men arrive: Harry Bright (Colin Firth), a charming

ex-musician, Sam Carmichael (Pierce Brosnan), her mother's true love, and Bill (Stellan Skarsgård), a famous adventurer.

Meryl Streep, who plays Sophie's mother, Donna, is excellent, and she's got a good voice, too. The rest of the cast is great, especially Julie Walters and Christine Baranski as Donna's girlfriends and singing partners. Pierce Brosnan can't sing very well, but his part adds to the fun.

The plot was interesting, but I especially loved the music. I really recommend this film.

1. They're a famous Swedish pop group.
2. She plays Sophie's mum.
3. He's planning to marry Sophie.
4. A famous adventurer.
5. They play Sophie's mother's girlfriends.
6. An actor who can't sing.

ABBA

⚓ Read and circle True or False.

1. Famous actors appear in *Mamma Mia!*
2. Sophie grew up with her mum and dad in Greece.
3. Her mum's diary says that her father is Pierce Brosnan.
4. She invites the three men to her wedding.
5. The music is a little boring.
6. The reviewer loved this film.

<input checked="" type="radio"/> True	<input type="radio"/> False
<input type="radio"/> True	<input type="radio"/> False
<input type="radio"/> True	<input type="radio"/> False
<input type="radio"/> True	<input type="radio"/> False
<input type="radio"/> True	<input type="radio"/> False
<input type="radio"/> True	<input type="radio"/> False



Test 4

Name: _____ Class: _____

1 Complete the words and phrases.

1. S m o g is a type of pollution caused by contaminants in the air.
2. The city's rubbish is buried in a l _____.
3. There is so much s _____ from factories that it is difficult to breathe.
4. Our school organizes a clean-up day to pick up l _____ in the park.
5. Experts say that car e _____ f _____ are one of the main causes of the air pollution.
6. People can get ill when there is t _____ w _____ near their homes.
7. Some cities pour untreated s _____ into rivers and streams.

2 Complete the labels.



Use public
transport



litter.



trees.

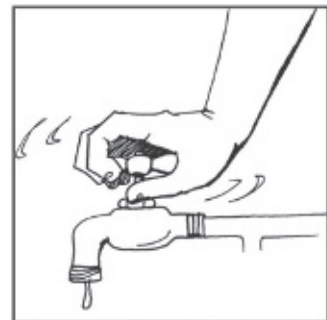

Save

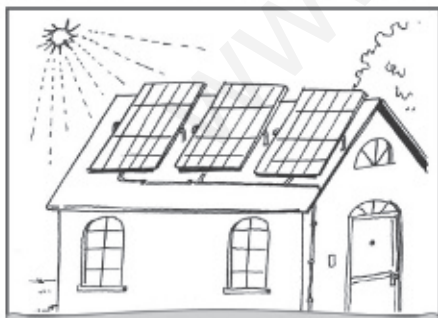

solar panels.



Eat

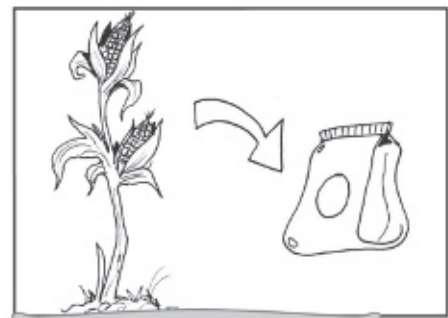

Use



Test 4

3 Complete the sentences.

1. New trees (plant) _____ *are planted* _____ every year.
2. The streets (decorate) _____ with coloured lights.
3. The rubbish (collect) _____ on our street every night.
4. These watches (make) _____ in Japan.
5. The garden (water) _____ every day.

4 Write questions for each answer.

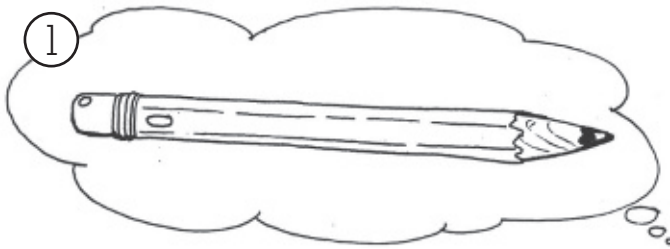

What are pencils made of?

Pencils are made of wood.

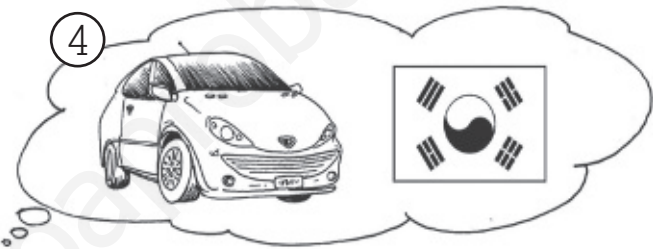

Those cars are made in *South Korea*.



This knife is made of *recycled plastic*.

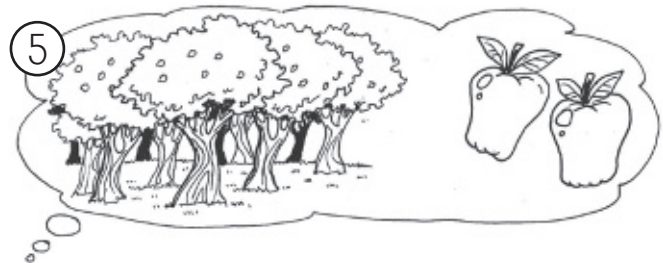

Apples are grown in *orchards*.



Diamonds are mined in *South Africa*.

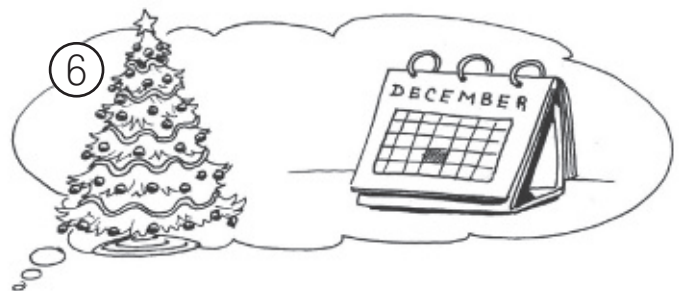

Christmas is celebrated on *25th December*.



5 Read and order the pictures.

TEENAGER FIGHTS FOR FOREST

Twelve-year-old Allison Blake is from Hamilton, Florida. She lives in a quiet neighbourhood near Old Creek Woods, one of the oldest forests in the area. There are plans to build a large road through the forest to reduce traffic in the city. Most people who live near the forest are against it. "When I heard about the plan," says Allison, "I wrote to local politicians. I didn't get much response, so I wrote to eighty schools asking children to sign a petition to stop them from destroying the forest. Ten thousand students signed the petition!" Allison wrote to famous singers, who agreed to give a "Save our forest!" concert

in Old Creek Woods. She got the media involved, too. Local TV channels broadcast the concert, and it was a great success. But Allison didn't stop there. She organized a children's march to the governor's office in Tallahassee. Over a thousand children went on the march, and Allison met the governor of Florida. She gave him the petition and explained why the forest was important. The governor wrote to her and said they were going to change the route of the new road. The future of this old forest is a lot brighter, and it's all thanks to Allison's efforts.



⚓ Underline the correct option.

- Allison Blake lives _____
 a) in Old Creek Woods. b) in Tallahassee, Florida. c) in Hamilton, Florida.
- Allison discovered plans _____
 a) to build a new road. b) to destroy her neighbourhood. c) to have a concert.
- Local politicians _____
 a) responded immediately. b) weren't very concerned. c) arranged a march.
- Allison wrote to schools to _____
 a) raise money. b) get students' support. c) contact the governor.
- She also organized _____
 a) a TV interview. b) a concert. c) an excursion.
- The governor talked to Allison _____
 a) on the phone. b) at the concert. c) at the march.
- Allison's campaign _____
 a) might save the forest. b) saved the forest. c) didn't save the forest.



Name: _____ Class: _____

1 Label the art supplies.

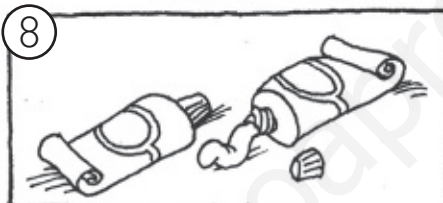
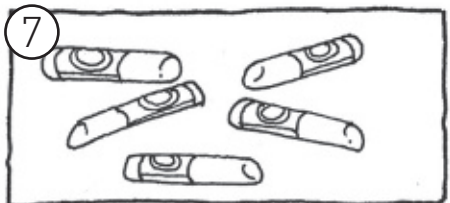
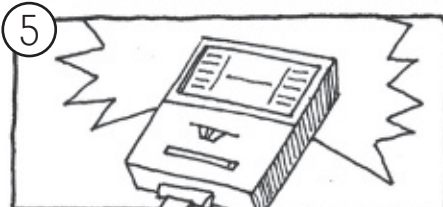
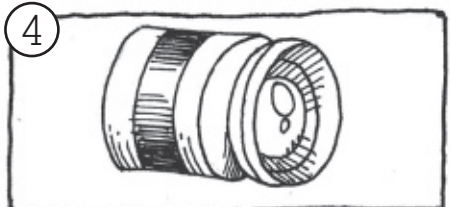
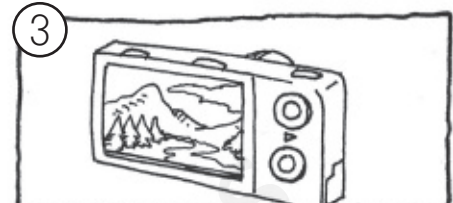
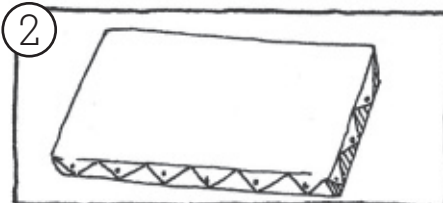
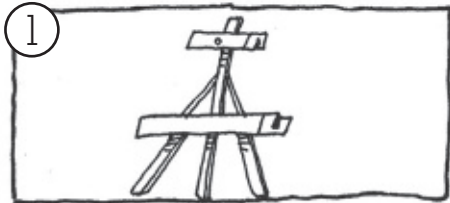

1. _____ *easel* _____

2. _____

3. _____

4. _____

5. _____

6. _____

7. _____

8. _____

9. _____

2 Read and write the art form.

1. A painting that is done with water-based paints.
2. The artist attaches pieces of pictures to a canvas.
3. A view of nature is shown in this art form.
4. This form shows objects arranged on a table.
5. This is a picture of the artist painted by himself or herself.
6. Art painted directly onto a wall.
7. Shapes that don't look like real things or people.
8. A picture that uses small pieces of coloured glass or stone.
9. In this art form, the artist paints another person.

_____ *watercolour* _____



3 Combine the sentences using *who*, *that* or *where*.

1. Van Gogh was a Dutch painter. He had an unhappy life.

Van Gogh was a Dutch painter who had an unhappy life.

2. My brother painted a picture. You can see it in this gallery.

3. This is the famous museum. You can see the Mona Lisa here.

4. We've got a new Art teacher. He can draw very well.

5. This is the digital camera. I got it for my birthday.

4 Report what the people said.

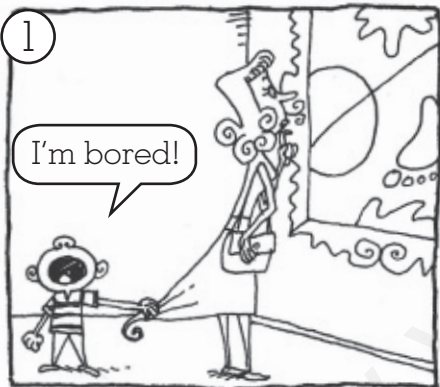

He said he

was bored.

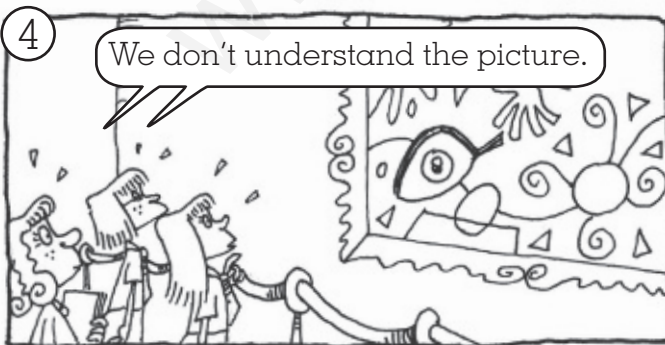
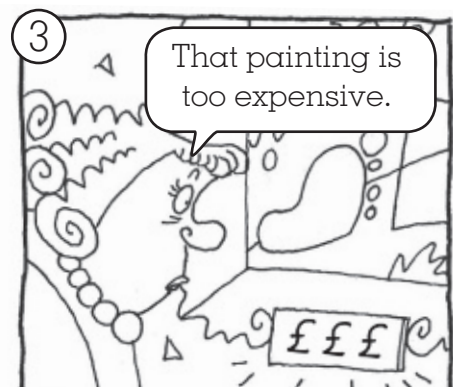



5 Read and mark (✓) the information that you can find in the text.

>> The Mona Lisa <<

Leonardo da Vinci painted this 77 cm x 53 cm beauty. It is now one of the most famous portraits in history, but nobody knows for sure who the woman was or the reason for her unusual smile. Some historians believe that the woman's name was Lisa Gherardini del Giocondo.

Leonardo started the painting in 1503 in Florence, Italy, and took a few years to complete it. Some people believe it was Leonardo's favourite work and that is why he didn't want to sell it. Finally it was sold to the king of France for lots of money, and was placed in the Louvre, a royal palace.

After the French Revolution, Napoleon Bonaparte liked the Mona Lisa so much that he took it to decorate his bedroom. When he was defeated,

authorities returned the painting to the Louvre, which was converted to a museum, where it safely remained for almost a century.

Then, in 1911, a thief stole the painting from its place in the Louvre. The search for the great work of art made the painting famous around the world. Police found it two years later, when a man offered to sell the painting for £50,000.

Today, to protect the Mona Lisa, it is kept in a thick, glass box in the Louvre. It hangs in the Salle d'États and is visited by millions of people every year.



the year the painting was finished

the owners of the painting

the woman's characteristics

the value of the painting

the name of a king

the size of the painting

the painter

the type of paints used

the woman's name

the thief's name

⚓ Complete the sentences.

1. The painting is probably a portrait of _____ *Lisa Gherardini del Giocondo* _____.
2. The first owner of the painting was _____.
3. The king of France put the painting in _____.
4. Napoleon used the painting to _____.
5. A thief tried to sell the painting for _____.
6. Now you can visit the Mona Lisa in _____.
7. The famous portrait hangs in _____.



Test 6

Name: _____ Class: _____

1 Complete the sentences.

1. Baseball is played on a _____ *baseball pitch* _____.
2. I celebrated my last birthday at a bowling _____.
3. They've got a grass football _____ at their school.
4. A standard golf _____ has got eighteen holes.
5. There's a great basketball _____ in the park.
6. The boxers entered the _____ and the crowd cheered loudly.
7. The _____ was full for the hockey match.
8. We go swimming in the indoor _____.

2 Label the sports equipment.

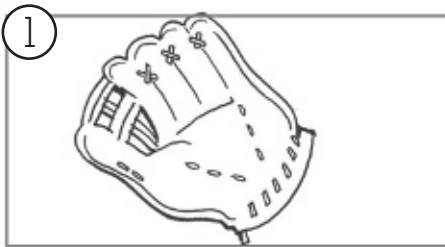

_____ *baseball glove* _____

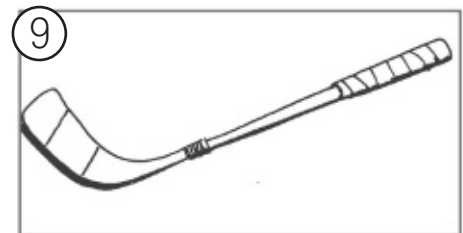
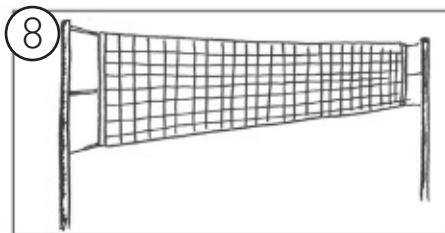
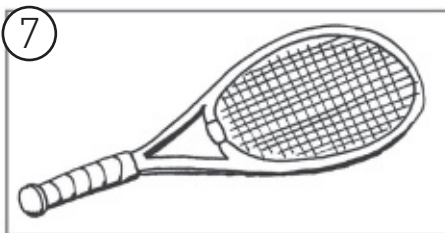
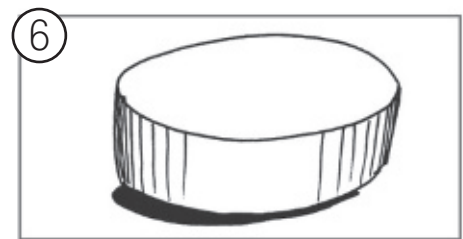
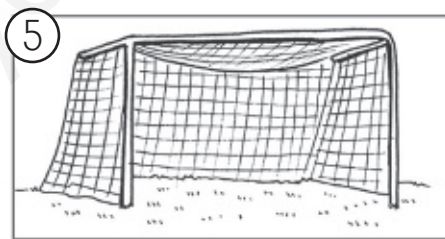
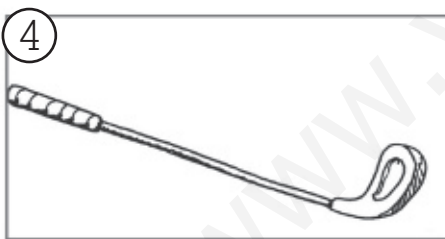
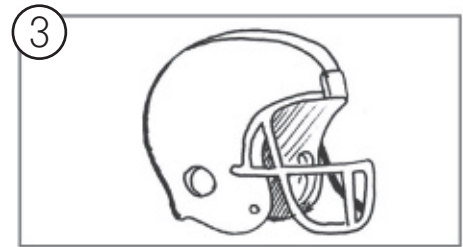
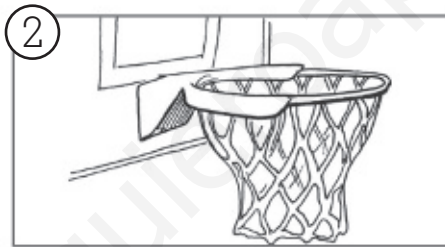



3 Answer the questions with *for* or *since*.

1. How long have you played baseball? (was a child)

I've played baseball since I was a child.

2. How long have you lived here? (six months)

3. How long have you had your glove? (five years)

4. How long have you played for this team? (last September)

5. How long have you been a professional? (2006)

6. How long have you been married? (two years)

4 Complete with the correct form of *need to*.

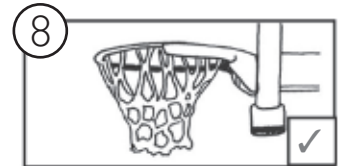
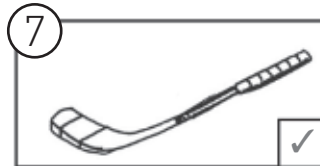
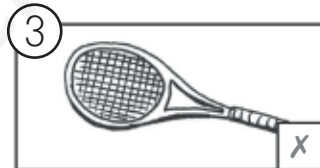
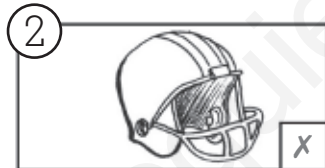

1. Paula _____ *needs to* _____ have a good pair of shoes to run the race.

2. James _____ wear a helmet to play basketball.

3. Lisa and Amanda _____ bring tennis rackets.

4. We _____ wear kits to play in the tournament.

5. Karen _____ have a baseball glove to play with us.

6. Jim _____ run 10 kilometres every day to be fit.

7. Maggie _____ buy a new hockey stick.

8. I _____ practise for the basketball game.



5 Read and match.

Babe Ruth, the Home Run King!

George Herman Ruth, known as "Babe Ruth," was one of the first sports superstars. He was born on 6th February, 1895, in Baltimore, Maryland. He had 1 sister named Mamie. Ruth's parents were very poor, so they sent him to an orphanage when he was 7 years old. There he learned how to play baseball. By the age of 15, he was playing for his school team. At the age of 19, Ruth had his first professional contract. He was a pitcher (the player who throws the ball) but he quickly developed a greater reputation as a hitter (the player who hits the ball with a bat). In 1930 Ruth was earning a salary of \$80,000 a year for the New York

Yankees. In the third game of the 1932 World Series against the Chicago Cubs at Wrigley Field, Babe hit the longest home run ever hit there. At the time of his retirement, he had an impressive record of 714 home runs. After baseball, Ruth lived a quiet life with his wife, Claire. When he died in 1948, more than 100,000 people went to his funeral. His shirt, number 3, was retired that same year.

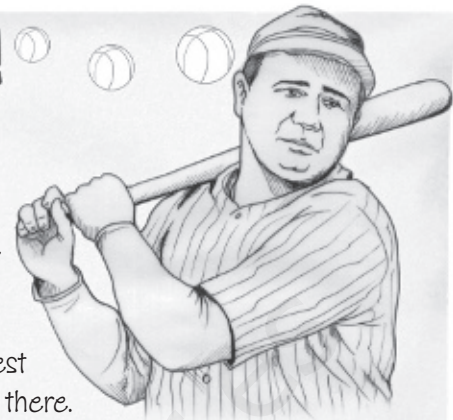

- 15
- 1895
- 714
- 1932
- 3
- 19
- 1948
- 7
- 1
- 80,000
- 100,000

- number of sisters
- age he became a professional
- age he went to an orphanage
- year of Wrigley Field's record home run
- number of home runs in his career
- year he was born
- number of people at his funeral
- year he died
- number on his shirt
- dollars a year
- age he played for his school team

⚓ Complete the sentences.

1. Babe Ruth was a famous player for the New York Yankees.
2. He grew up in an orphanage because _____.
3. He started playing baseball when _____ years old.
4. He began his career as a _____.
5. He hit the longest home run at Wrigley Field in the _____.
6. He's famous because he had an impressive record of _____.



Test 7

Name: _____ Class: _____

1 Circle the correct option.

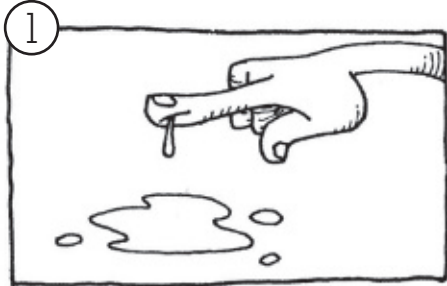

bone / blood

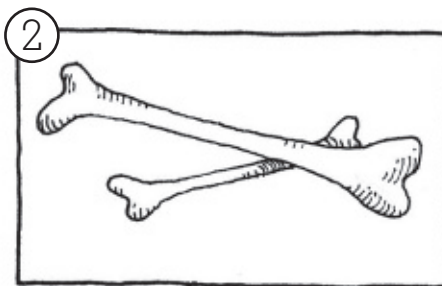

kidneys / bones

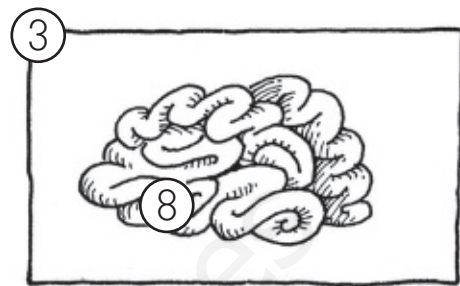

brain / muscle



lungs / heart

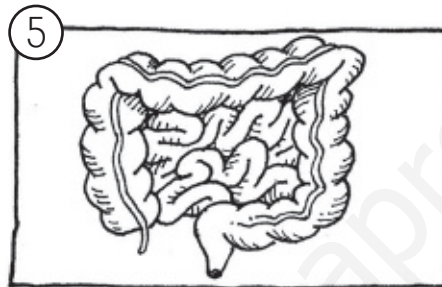

liver / intestines

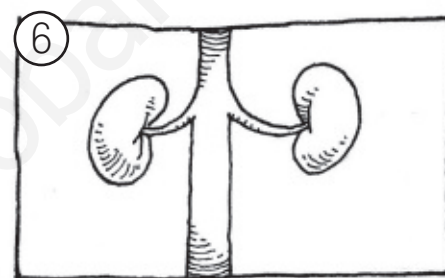

lungs / kidneys

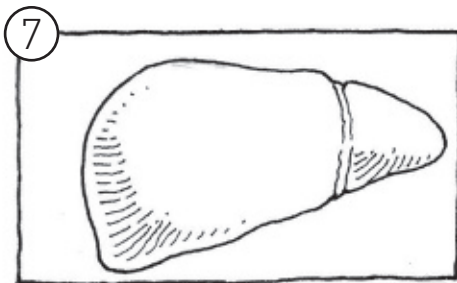

heart / liver

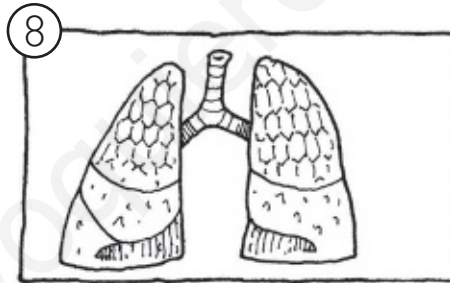

blood / lungs

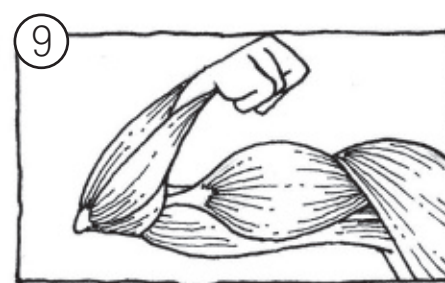

muscles / intestines

2 Complete the sentences.

1. You _____ chew _____ food with your teeth.
2. Some people _____ loudly when they sleep.
3. I'm allergic to flowers. They make me _____.
4. It's normal to _____ when you're tired.
5. Drink some honey with lemon when you _____.
6. It's usually not good to _____ a mosquito bite.
7. Sometimes eating spicy food can cause you to _____.



3 Write sentences.

1. have / enough milk, / not drink / you / if / bad teeth

If you don't drink enough milk, you'll have bad teeth.

2. you / get bad marks / not study / if / you

You'll get bad marks if you don't study.

3. lots of junk food, / if / you / eat / not get enough nutrients / your body

4. you / if / you / not sleep enough / feel tired

5. not go / to Sophie's party, / if / she / be sad / she

6. you / learn / if / you / read a lot / lots of new words

7. if / you / not tidy / be angry / your parents / your bedroom,

4 Complete with reflexive pronouns.

1. Think before you speak or you could embarrass _____ yourself _____.

2. Beth hurt _____ in PE today.

3. My little brother can't dress _____.

4. They really enjoyed _____ at the theme park.

5. The pizza was very hot and we burned _____.

6. Be careful not to cut _____ with the knife.

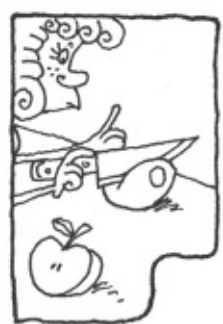



5 Read and number the headings.

The flu

1. _____

The flu (influenza) is an infection of the nose, throat and lungs that is caused by a virus. The flu can spread from person to person. Most people with the flu are ill for about a week, but then they feel better.

2. _____

Most people with the flu feel tired and get a fever, a headache, a dry cough, a sore throat, a runny nose and sore muscles. Some people, especially children, also get stomach problems. The cough can last two weeks or more.

3. _____

Healthy adults can infect others with the flu before symptoms appear, or as many as five days after having flu symptoms.

4. _____

✓ Get vaccinated.

✓ Wash your hands frequently.

✓ Eat healthy food and take care of yourself to help your body resist the flu and other infections.

5. _____

No. If you think you've got the flu, call your doctor. Make sure to get rest and drink plenty of fluids. Also, stay at home to avoid spreading the virus. And remember to cover your nose and mouth when you cough and sneeze.

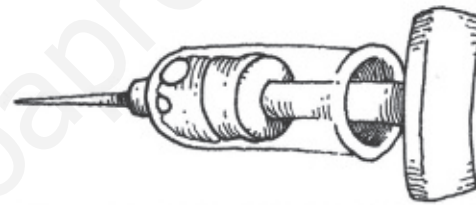

What are the symptoms of the flu?

Is there a cure for the flu?

How long can an ill person spread the flu to others?

What is the flu?

What can I do to avoid getting the flu?

⚓ Read and circle *True* or *False*.

- | | | |
|--|------|-------|
| 1. This text was written for medical experts. | True | False |
| 2. You can probably find this text at a doctor's office. | True | False |
| 3. You can't take medicine to cure the flu. | True | False |
| 4. The flu is primarily a stomach virus. | True | False |
| 5. You can spread the flu before you get symptoms. | True | False |
| 6. For children, the flu can last more than two weeks. | True | False |
| 7. You should call the doctor if you've got the flu. | True | False |
| 8. A healthy diet can help you avoid catching the flu. | True | False |
| 9. You can't prevent infection by getting vaccinated. | True | False |
| 10. You should go to school if you've got the flu. | True | False |



Name: _____ Class: _____

1 Read and write the letter.

a) talk show b) weather report c) cartoon d) quiz show

e) documentary f) soap opera g) news h) drama i) traffic report

Reports from our correspondents around the world.	g	Nigel Brown looks at the sky and gives a forecast for the week ahead.		Detailed information about the situation on our roads.		<i>The Wilsons.</i> Britney wants her new boyfriend to meet her parents. He isn't so sure about it...	
---	---	---	--	--	--	---	--

<i>Camera Eye</i> tells us all about the life of the kangaroos.		Another adventure of your favourite animated heroes.		Do you want to win a million pounds with our host Fiona Barlett?		Today, Nora Wimpfree talks to the bestselling writer John Fisham.		In today's episode, a group of space tourists gets lost on a mysterious planet.	
---	--	--	--	--	--	---	--	---	--

2 Match and complete the sentences.

breaking exclusive latest live news overseas special

reader correspondent coverage headlines interview news report

- An overseas correspondent is a reporter who works in another country.
- The _____ are the titles of the most recent news stories.
- A _____ is a detailed report about a news story.
- The person who reads the news is a _____.
- _____ is showing an event as it is happening.
- An _____ is a conversation with a reporter from only one television station.
- News that is arriving at the studio right now is _____.



3 Rewrite the sentences in the passive.

1. A thief stole my bicycle three days ago.

My bicycle was stolen three days ago by a thief.

2. Rescue workers took people to the hospital.

3. The Mayas built this pyramid in the 13th century.

4. The coast guard rescued several people.

5. The police arrested three men.

4 Write a question for each headline.

Volcano erupts covering village

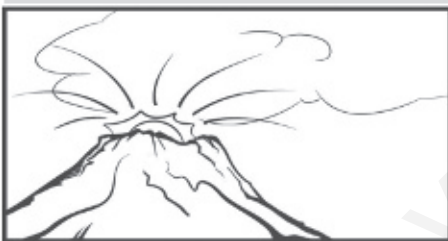

people / hurt

Were any
people hurt?

Lion captured downtown



how / it / capture

Another dinosaur fossil found



where / it / find

Dolphins trapped on a local beach



how many dolphins / trap

Paintings stolen from the art museum

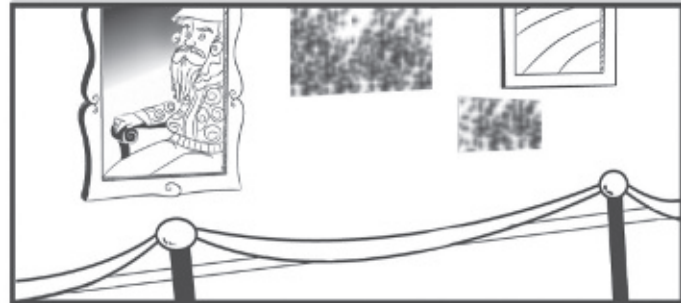

when / they / steal



5 Read and mark what really happened (✓ or X).

Traffic situation on M42

Traffic was stopped for three hours this morning as authorities removed thousands of tiny toy cars from the street.

At 8.15, a cat ran across the street, causing a large lorry full of toy cars to hit a telephone pole. The cat and the driver of the truck were unhurt.

Unfortunately, the lorry's back door opened and thousands of little toy cars fell out onto the street and rolled away in every direction. Other vehicles could not pass through the area, and people

who tried to walk away from the scene fell down because of the cars.

Police officers directed traffic around the accident and many people helped pick up the cars, and put them back into the lorry.

"It was a pretty amazing scene," said Officer Murphy. "To the neighbourhood children, it was like Christmas morning. They asked if they could keep some of the cars.

Unfortunately, they couldn't." The streets were clear by 11.30 a.m.

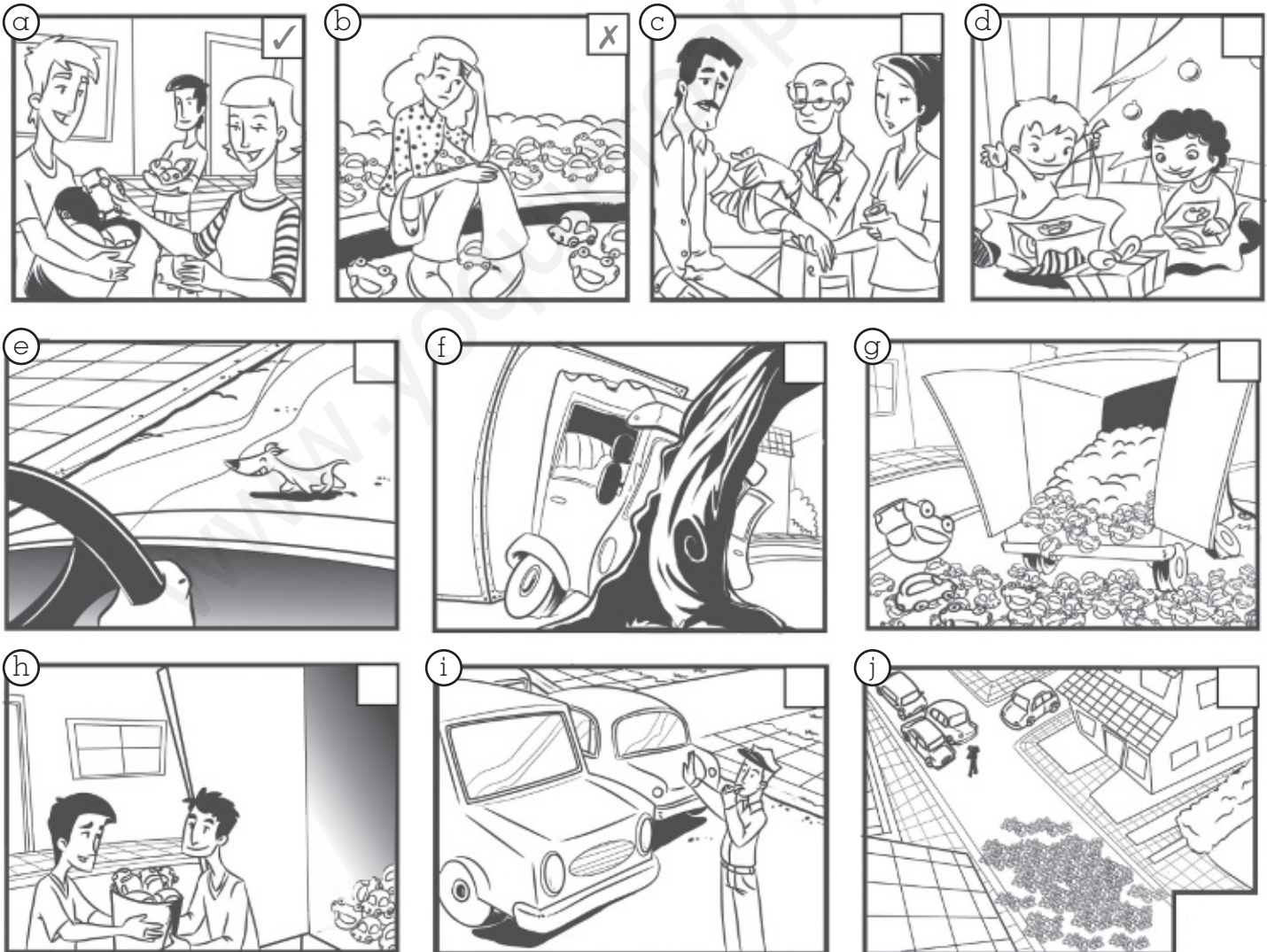



Name: _____ Class: _____

1 Complete the adjectives and the nouns.

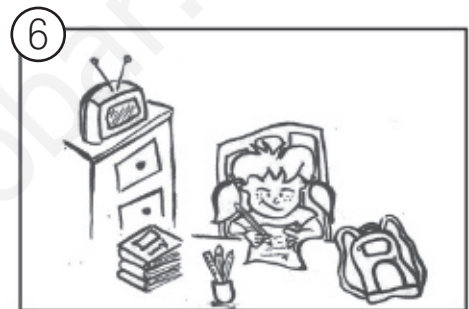
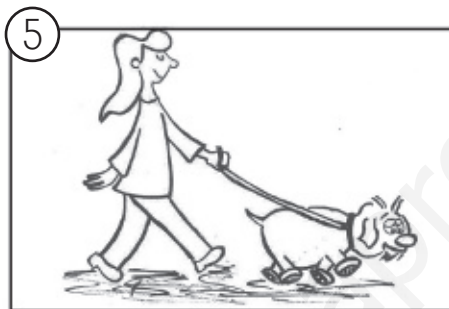
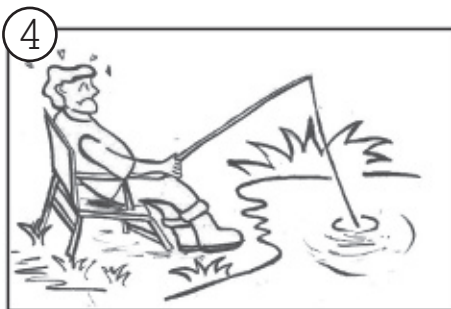

1
c o u r a g e o u s
c o u r a g e

2
h _ _ _ e _ _ _
h _ _ _ e _ _ _ y

3
f _ _ _ g _ _ _ i n _ _
f _ _ _ g _ _ _ e _ _ _ _ _

4
p _ _ _ i _ _ n _ _
p _ _ _ i _ _ _ _ e

5
l _ _ _ a _ _
l _ _ _ a _ _ t _ _

6
r _ _ _ p _ _ _ s _ _ b _ _ _
r _ _ _ p _ _ n _ _ _ b _ _ l _ _ _ y

2 Underline the correct option.

HOW TO BE A GOOD FRIEND

You should always *stand up for* / *look up to* your friends — especially if somebody *is telling a lie about* / *getting even with* them. Always *tell on* / *tell the truth to* them — they trust you to say what you really think. And don't try to *tell a lie to* / *get even with* them if they make a mistake, like losing one of your video games or forgetting your birthday. If you see them *telling the truth* / *cheating in an exam*, talk to them and help them to study. That way, they can do well on the next test. Remember to always *look up to* / *tell on* people like your best teachers or your parents. If you do, you will always act correctly.



3 Write sentences.

1. find a fly in my soup / tell the waiter

If I found a fly in my soup, I'd tell the waiter.

I'd tell the waiter if I found a fly in my soup.

2. get lost in the city / ask for directions

3. see an angry dog / run fast

4. get too much change / return the money

5. a friend ask me to sing in public / be embarrassed

4 Complete the question for each answer.



Where would you live if you were a famous singer?

I'd live in a big house with a swimming pool.

If a teacher, lots of homework?

No, I wouldn't.

What buy £500?

Nothing. I'd put it in the bank.

If a superhero, what power you have?

I'd be able to fly.





5 Read and write the names of the awards.

YOUNG PEOPLE'S AWARDS

Amazing achievements are recognized every year at the Young People's Awards Ceremony. There are six categories of awards: **Courage in the Face of Illness, Helping Hand, Hometown Hero, Giving Happiness, Incredible Friend and Bridge Across Cultures.**

1. Helping Hand

Daniel Jones was nominated because he spends his free time helping his neighbours to clean their houses. He even walks their pets and goes to the supermarket for them, but he doesn't accept money for his work.

2. _____

Michael Rumley visits children in the hospital every day after school. He tells them jokes and does magic tricks to make them laugh and forget about their health problems.

3. _____

Angela Robinson has got a rare blood condition. But she has achieved a lot. She has written a new children's book to help others understand life with this illness — and she donated the money to the study of this disease.

4. _____

Lindsay Roland doesn't think she did anything unusual, but her friend Amanda

Knightley disagrees. Amanda needed a kidney transplant. Lindsay did medical tests to see if she could help. Then she had surgery to give one of her kidneys to her friend. Both girls are doing fine.

5. _____

Xueping Han was nominated for this award for helping Chinese students to improve their English. She has also organized several events to celebrate Chinese culture and to teach other students how to speak Chinese.

6. _____

Victor Norse was walking home from school when he saw a strange light in his neighbour's windows. He realized that his neighbour's house was on fire. He immediately called the fire brigade and shouted to wake up his neighbour, who escaped without injury.

⚓ Write the names.

1. She made a great sacrifice for her friend.

2. She's a writer.

3. He knows how to do magic tricks.

4. She speaks Chinese.

5. He saved his neighbour.

6. She needed a new kidney.

7. He helps his neighbours at home.

Lindsay Roland



Test Answers

Diagnostic Test

1

- 1 e
- 2 f
- 3 a
- 4 d
- 5 g
- 6 h
- 7 c
- 8 b

- 2 they have to set the table
- 3 They say they have to take out the rubbish.
- 4 They say they have to sweep the road.
- 5 He says he has to do the washing-up.
- 6 He says he has to dust the statue.
- 7 They say they have to walk the dogs.
- 8 He says he has to vacuum the temple.

2

- 2 There isn't going to be a tsunami.
- 3 There's going to be an eruption.
- 4 The trees are going to fall down.
- 5 A hurricane is going to form.
- 6 A tornado isn't going to form.

3

- 2, 3, 1, 4

4

- atom; credit cards; stethoscope; robot; brownies
- 2 will have toys with batteries
- 3 will use credit cards
- 4 will eat chocolate brownies
- 5 will discover the atom
- 6 will cure many diseases

5

- Answers will vary.

6

- 2, 6, 8, 3
- 4, 1, 7, 5

7

- 2 If you add too much sugar, it tastes bad.
- 3 If you freeze vegetables, they stay fresh.
- 4 If you prepare food too early, it doesn't taste good.
- 5 If you grill meat, it's healthier.

Test 1

1

- 2 sunburnt
- 3 pearl
- 4 coconut
- 5 seaweed
- 6 palm tree
- 7 shade
- 8 coral
- 9 Oysters

2

- 2 rotten
- 3 smooth
- 4 slimy
- 5 rough
- 6 loud
- 7 creamy
- 8 crunchy
- 9 disgusting

3

- 2 Have you ever climbed
- 3 Have you ever gone
- 4 Have you ever seen
- 5 Have you ever touched

4

- 2 She hasn't climbed any volcanoes.
- 3 He hasn't eaten snails.
- 4 They have seen lots of films.
- 5 She has read two books.

5

- Virgin Islands → Anguilla →
- Monserrat → Martinique →
- Trinidad and Tobago → Aruba

- 2 [the Virgin Islands] They went scuba diving in Anguilla.
- 3 [Martinique] A volcanic eruption destroyed part of Monserrat.

- 4 [earthquakes] There are still eruptions in Monserrat.
- 5 [architecture] The food in Martinique is really different.
- 6 [land] She thinks that it's sometimes boring on the boat.

Test 2

1

- 2 tuba
- 3 violin
- 4 drums
- 5 clarinet
- 6 flute
- 7 trombone
- 8 keyboard
- 9 saxophone

2

- 2 pop
- 3 country
- 4 jazz
- 5 heavy metal
- 6 samba
- 7 classical

3

- 2 He hasn't won a Grammy yet.
- 3 He hasn't recorded a CD yet.
- 4 He has already been on TV.
- 5 He has already played with a pop star.
- 6 He hasn't travelled to New York yet.

4

- Have you finished; did; haven't bought; bought; Have you used; got

5

- The birth of samba

2 b

3 c

4 c

5 a

6 b

7 b

8 a





Test Answers

Test 3

- 1
- 2 scriptwriter
- 3 stuntman
- 4 cameraman
- 5 director
- 6 actor
- 7 producer
- 8 make-up artist
- 9 extras

2

- 2 a
- 3 b
- 4 b
- 5 c
- 6 b
- 7 a
- 8 b
- 9 c

3

- 2 it
- 3 her
- 4 him
- 5 us
- 6 them

4

- 2 She told her to look at the poster.
- 3 She told her not to use a pen.
- 4 She told him not to open the window.
- 5 She told him to turn off the mobile phone.
- 6 She told them to listen carefully.
- 7 She told her to write the answer on the board.

5

- 2 Meryl Streep
- 3 Sky
- 4 Bill
- 5 Julie Walters, Christine Baranski
- 6 Pierce Brosnan

- 2 False
- 3 False
- 4 True
- 5 False
- 6 True

Test 4

- 1
- 2 landfill
- 3 smoke
- 4 litter
- 5 exhaust fumes
- 6 toxic waste
- 7 sewage

2

- 2 Pick up
- 3 Plant
- 4 water
- 5 Put up
- 6 organic food
- 7 biodegradable products

3

- 2 are decorated
- 3 is collected
- 4 are made
- 5 is watered

4

- 2 What is this knife made of?
- 3 Where are diamonds mined?
- 4 Where are those cars made?
- 5 Where are apples grown?
- 6 When is Christmas celebrated?

5

- 1, 3, 6
- 5, 4, 2
- 2 a
- 3 b
- 4 b
- 5 b
- 6 c
- 7 b

Test 5

- 1
- 2 canvas
- 3 digital camera
- 4 lens
- 5 flash
- 6 watercolours
- 7 pastels
- 8 oil paints
- 9 spray paints

2

- 2 collage
- 3 landscape
- 4 still life
- 5 self-portrait
- 6 mural
- 7 abstract
- 8 mosaic
- 9 portrait

3

- 2 My brother painted a picture that you can see in this gallery.
- 3 This is the famous museum where you can see the Mona Lisa.
- 4 We've got a new Art teacher who can draw very well.
- 5 This is the digital camera that I got for my birthday.

4

- 2 He said he didn't like abstract art.
- 3 She said that painting was too expensive.
- 4 They said they didn't understand the picture.
- 5 They said he couldn't take photos.

5

- ✓ The value of the painting
- ✓ The size of the painting
- ✓ The woman's characteristics
- ✓ The owners of the painting

- 2 the king of France
- 3 his palace
- 4 decorate his bedroom
- 5 £50,000
- 6 the Louvre
- 7 the Salle d'États



Test Answers

Test 6

- 1
- 2 alley
- 3 pitch
- 4 course
- 5 court
- 6 ring
- 7 (hockey) arena
- 8 (swimming) pool

- 2
- 2 basketball hoop
- 3 helmet
- 4 golf club
- 5 goal
- 6 hockey puck
- 7 tennis racket
- 8 volleyball net
- 9 hockey stick

- 3
- 2 I've lived here for six months.
- 3 I've had my glove for five years.
- 4 I've played for this team since last September.
- 5 I've been a professional since 2006.
- 6 I've been married for two years.

- 4
- 2 doesn't need to
- 3 don't need to
- 4 need to
- 5 needs to
- 6 doesn't need to
- 7 needs to
- 8 need to

- 5
- 15 – age he played for his school team
- 1895 – year he was born
- 1932 – year of Wrigley Field's record home run
- 3 – number on his shirt
- 19 – age he became a professional
- 1948 – year he died
- 7 – age he went to an orphanage
- 1 – number of sisters
- 80,000 – dollars a year
- 100,000 – number of people at his funeral

- 2 his parents were very poor
- 3 he was seven
- 4 pitcher
- 5 1932 World Series
- 6 home runs

Test 7

- 1
- 2 bones
- 3 brain
- 4 heart
- 5 intestines
- 6 kidneys
- 7 liver
- 8 lungs
- 9 muscles

- 2
- 2 snore
- 3 sneeze
- 4 yawn
- 5 cough
- 6 scratch
- 7 have the hiccups

- 3
- 3 If you eat lots of junk food, your body won't get enough nutrients.
- 4 You'll feel tired if you don't sleep enough.
- 5 If she doesn't go to Sophie's party, she'll be sad.
- 6 You'll learn lots of new words if you read a lot.
- 7 If you don't tidy your bedroom, your parents will be angry.

- 4
- 2 herself
- 3 himself
- 4 themselves
- 5 ourselves
- 6 yourself

- 5
- 2 What are they symptoms of the flu?
- 3 How long can an ill person spread the flu to others?
- 4 What can I do to avoid getting the flu?
- 5 Is there a cure for the flu?

- 2 True
- 3 True
- 4 False
- 5 True
- 6 False
- 7 True
- 8 True
- 9 False
- 10 False

Test 8

- 1
- b, i, f
- e, c, d, a, h

- 2
- 2 latest headlines
- 3 special report
- 4 newsreader
- 5 Live coverage
- 6 exclusive interview
- 7 breaking news

- 3
- 2 People were taken to the hospital by rescue workers.
- 3 This pyramid was built by the Mayas in the 13th century.
- 4 Several people were rescued by the coast guard.
- 5 Three men were arrested by the police.

- 4
- How was it captured?
- Where was it found?
- How many dolphins were trapped?
- When were they stolen?

- 5
- c
- d
- e
- f
- g
- h
- i
- j



Test Answers

Test 9

1

- 2 honest; honesty
- 3 forgiving; forgiveness
- 4 patient; patience
- 5 loyal; loyalty
- 6 responsible; responsibility

2

- telling a lie about
- tell the truth to
- get even with
- cheating in an exam
- look up to

3

- 2 If I got lost in the city, I'd ask for directions.
I'd ask for directions if I got lost in the city.
- 3 If I saw an angry dog, I'd run fast.
I'd run fast if I saw an angry dog.
- 4 If I got too much change, I'd return the money.
I'd return the money if I got too much change.
- 5 If a friend asked me to sing in public, I'd be embarrassed.
I'd be embarrassed if a friend asked me to sing in public.

4

- you were; would you give; would you; if you had; you were; would

5

- 2 Giving happiness
- 3 Courage in the face of illness
- 4 Incredible friend
- 5 Bridge across cultures
- 6 Hometown hero

- 2 Angela Robinson
- 3 Michael Rumley
- 4 Xueping Han
- 5 Victor Norse
- 6 Amanda Knightley
- 7 Daniel Jones



Values



* Values

Unit 1 Value: Celebrating your achievements.	104
Unit 2 Value: Being ambitious.	108
Unit 3 Value: Staying away from pirated films	111
Unit 4 Value: Taking care of the Earth.	114
Unit 5 Value: Expressing yourself	119
Unit 6 Value: Playing fair	122
Unit 7 Value: Exercising regularly	126
Unit 8 Value: Looking at the positive	129
Unit 9 Value: Doing the right thing	131



www.yoquieroaprobar.es





Unit 1 Value

Celebrating your achievements

⚓ Make a wall of fame.



1. Colour and cut out the parts of the star.



2. Stick the parts of the star together.

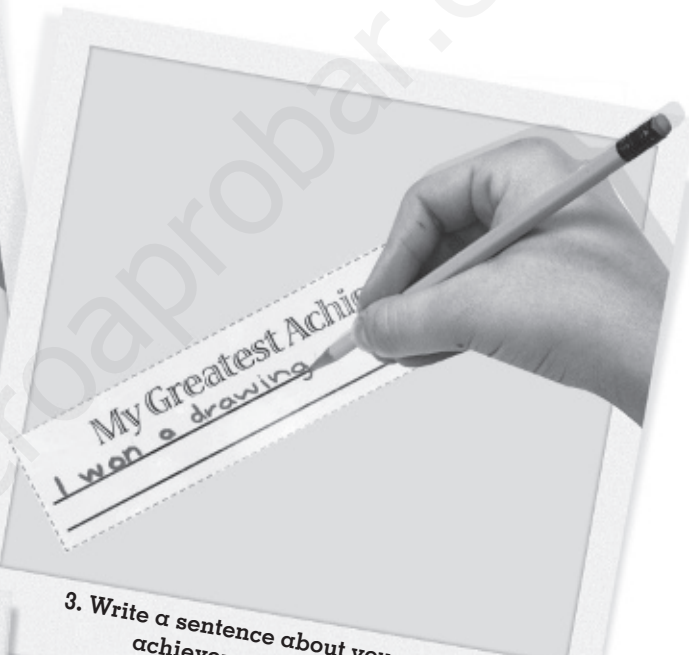

3. Write a sentence about your greatest achievement on the label.

4. Dip your hand in paint and put your handprint on your star.



5. Stick the label onto the star.



6. Decorate your star with glitter.



Unit 1 Value

Celebrating your achievements

✚ Make a wall of fame.

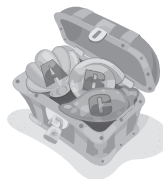

www.yoquieroaprobar.es

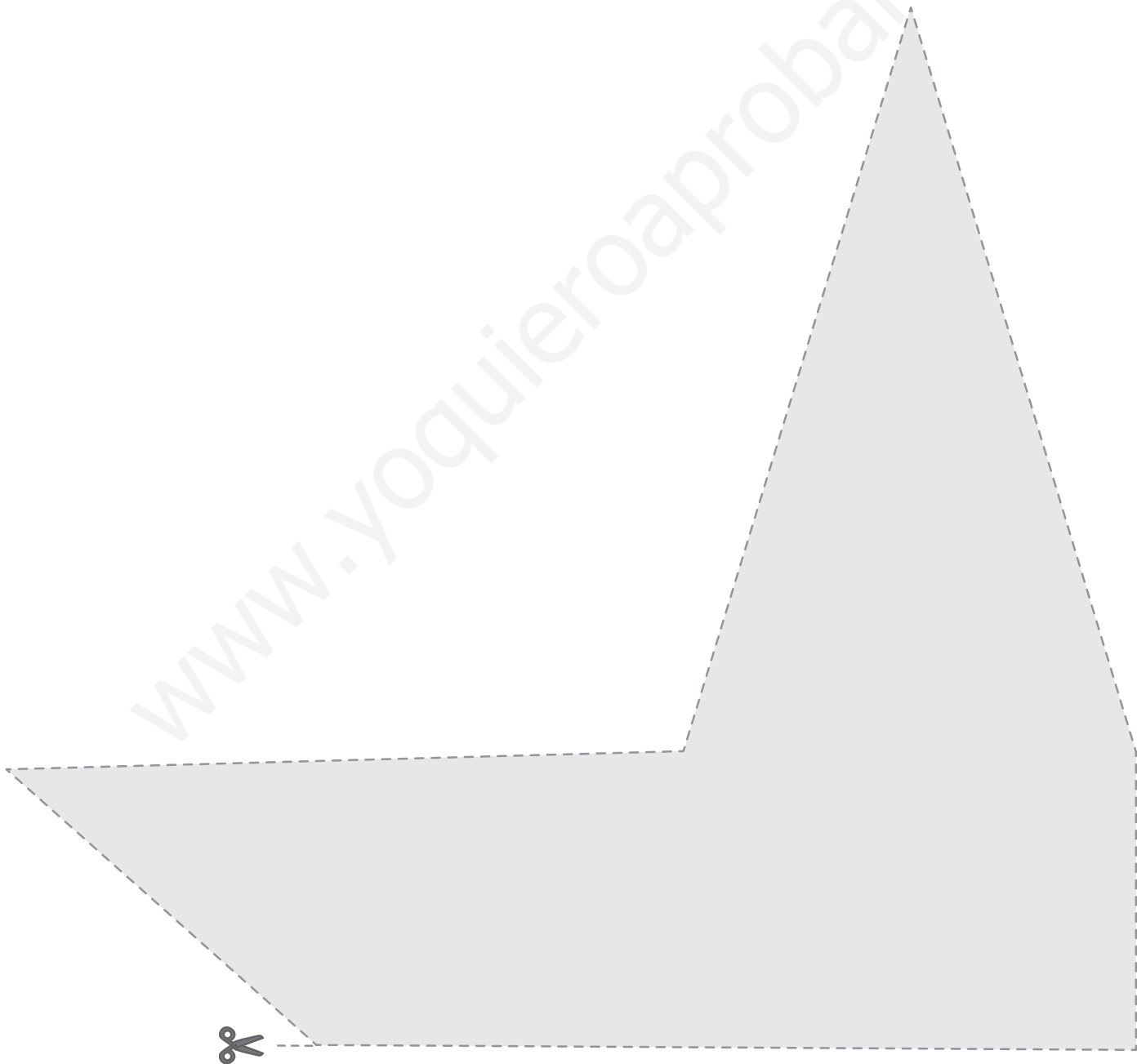

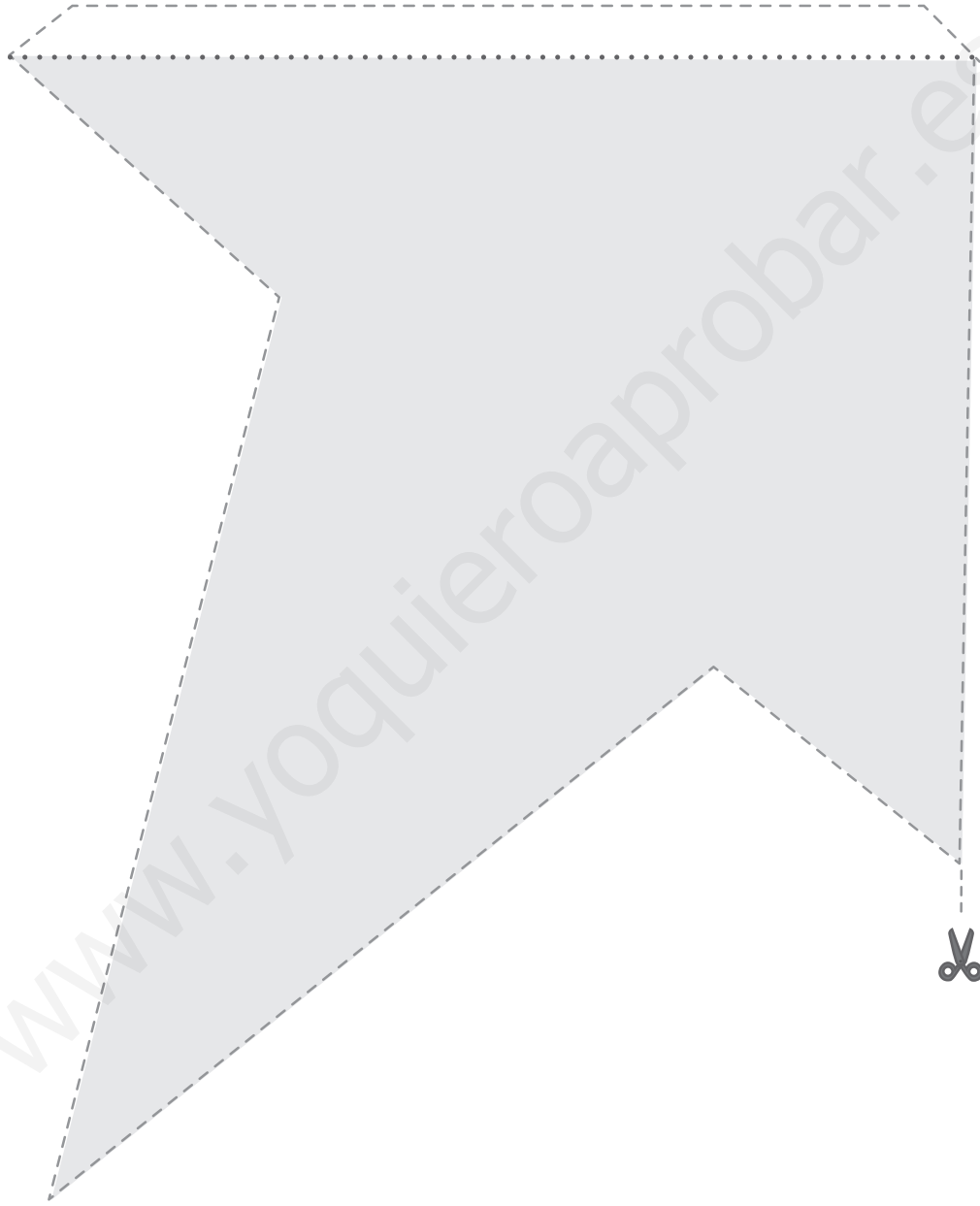

www.yoquieroaprobar.es

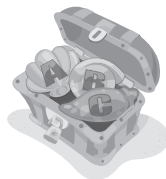

My Greatest Achievement



Unit 2 Value

Being ambitious

⚓ Make a lifetime *To do list*.



1. Colour and cut out the parts of the *To do list*.



2. Paste the parts of the list together.



4. Stick your *To do list* onto a sheet of card.



3. Write something you want to do in your lifetime on the lines.



5. Display your lifetime *To do list* and remember to follow your dreams.



Unit 2 Value

Being ambitious

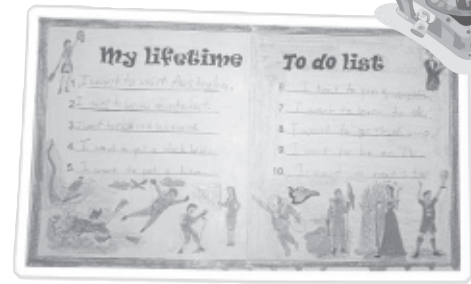
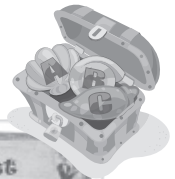

✂ Make a lifetime *To do list*.



My lifetime

1. _____
2. _____
3. _____
4. _____
5. _____

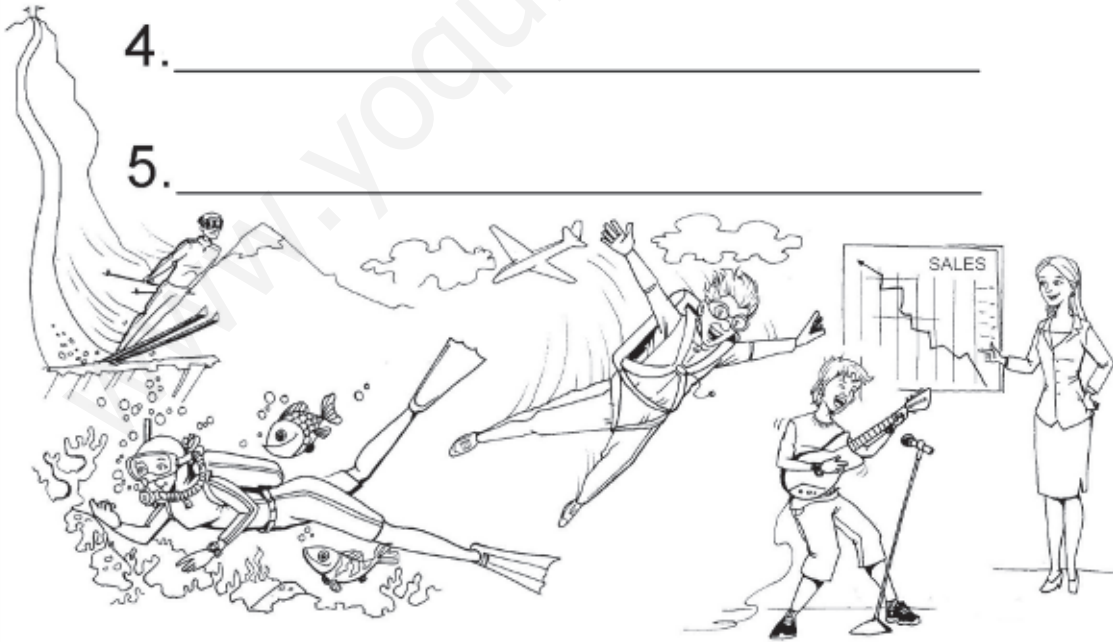



To do list

NOBEL PRIZE



6. _____

7. _____

8. _____

9. _____

10. _____





Unit 3 Value

Staying away from pirated films

⚓ Make an antipirating poster.

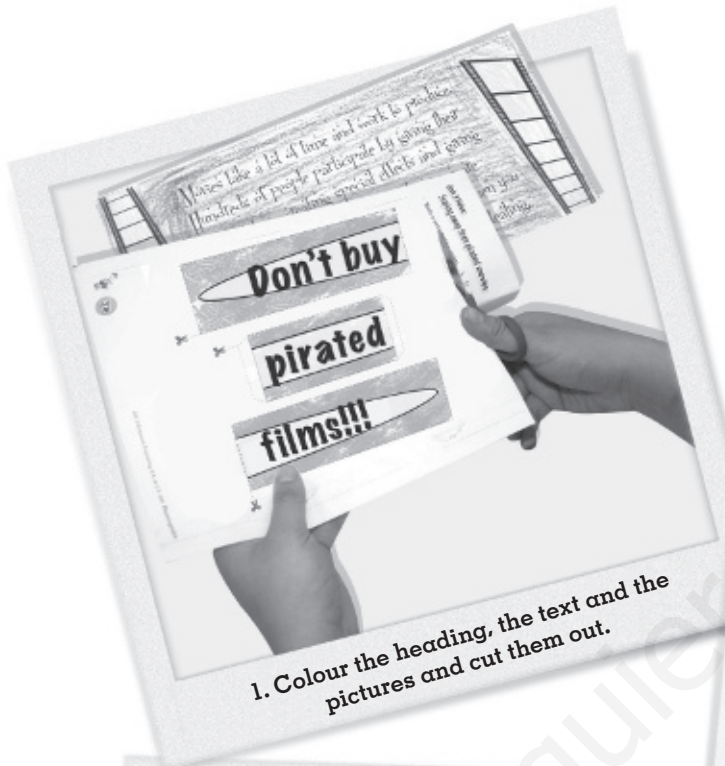

1. Colour the heading, the text and the pictures and cut them out.



2. Choose some magazine cutouts about films.

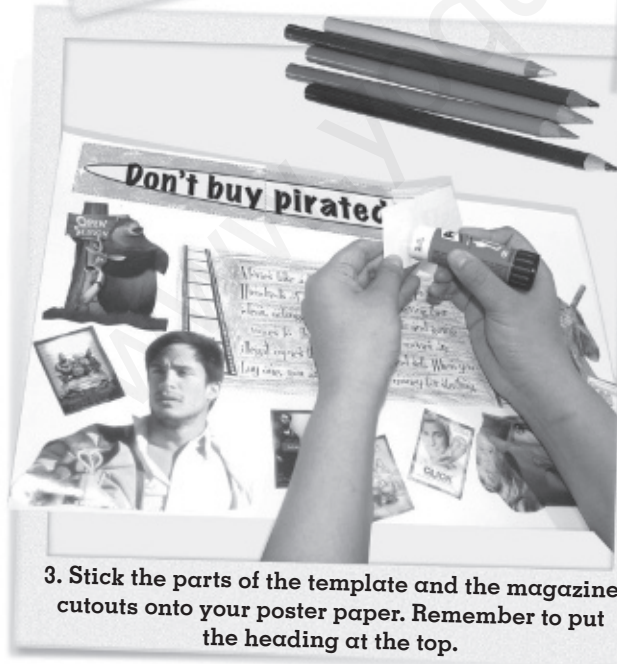

3. Stick the parts of the template and the magazine cutouts onto your poster paper. Remember to put the heading at the top.



4. Display your poster and remember that buying pirated films is a crime.



Unit 3 Value

Staying away from pirated films

✚ Make an antipirating poster.

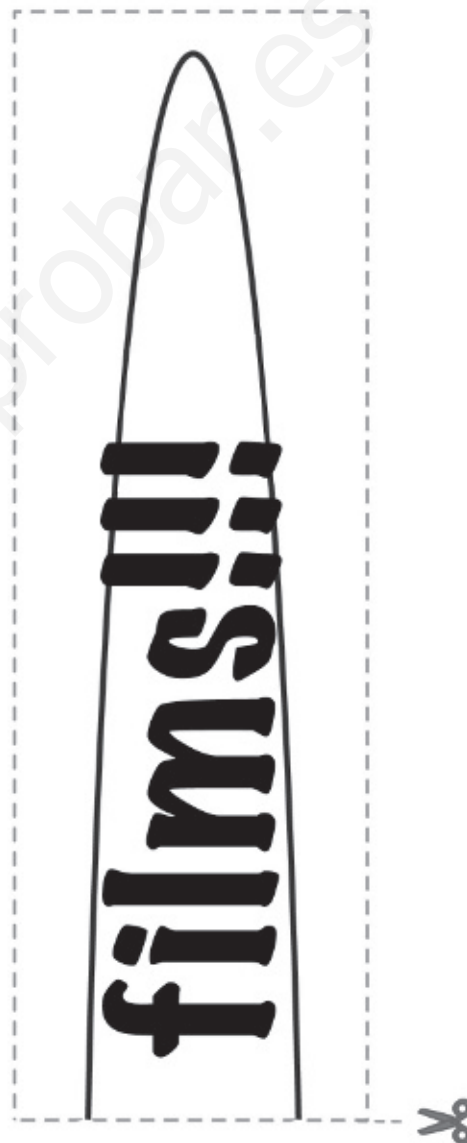

Films take lots of time and work to produce. Hundreds of people participate by giving their ideas, acting, creating special effects and giving voices to the characters. Pirated films are illegal copies that people create and sell. When you buy one, you are giving people money for stealing.

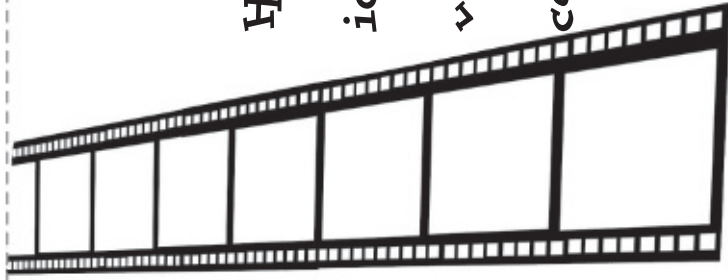



Unit 4 Value

Taking Taking care of the Earth

⚓ Make a globe.



1. Colour and cut out the parts of the globe.

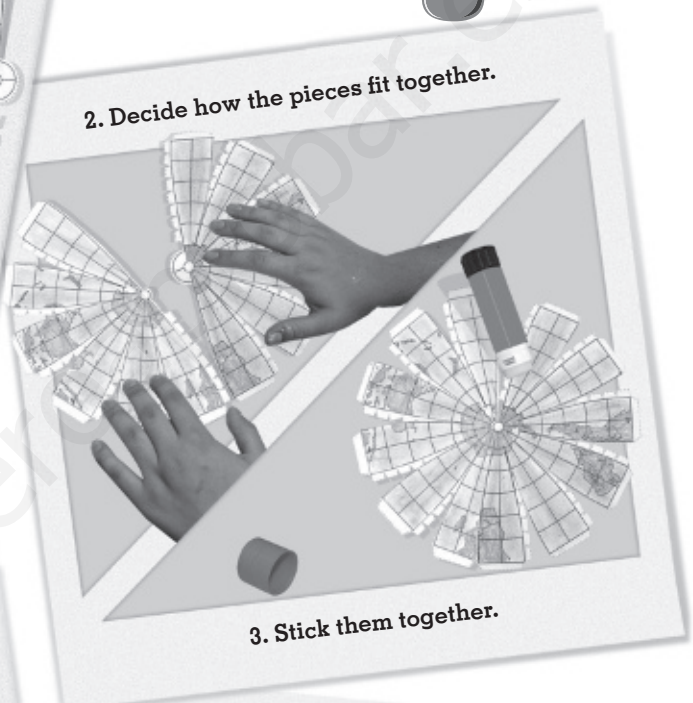

2. Decide how the pieces fit together.

3. Stick them together.

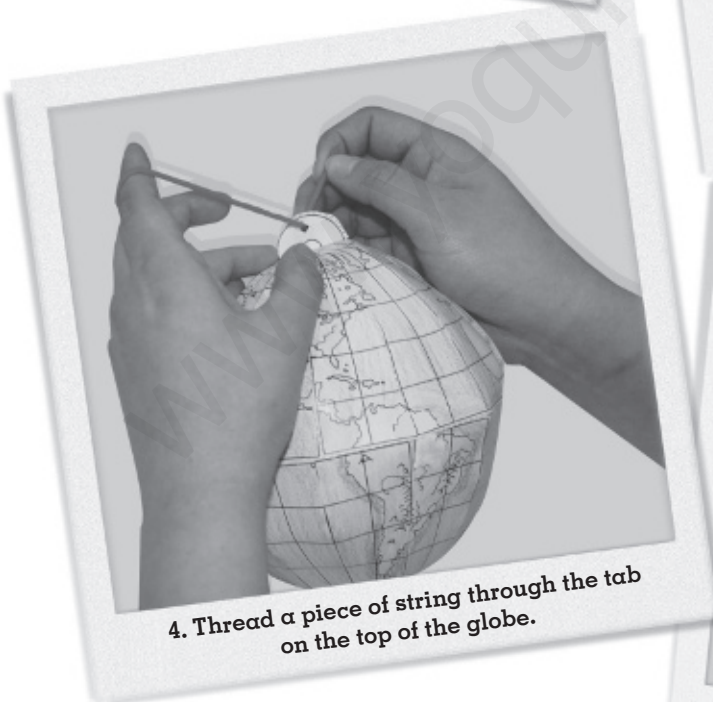

4. Thread a piece of string through the tab on the top of the globe.

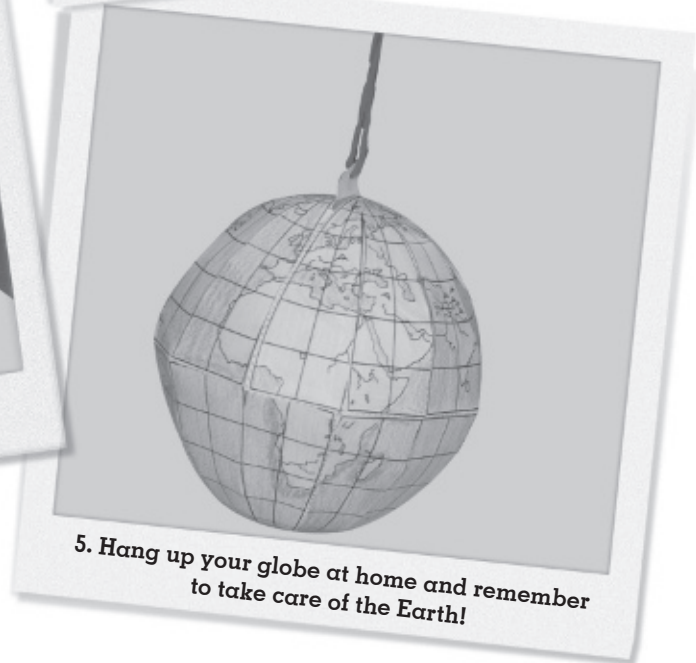

5. Hang up your globe at home and remember to take care of the Earth!



Unit 4 Value

Taking care of the Earth

✚ Make a globe.

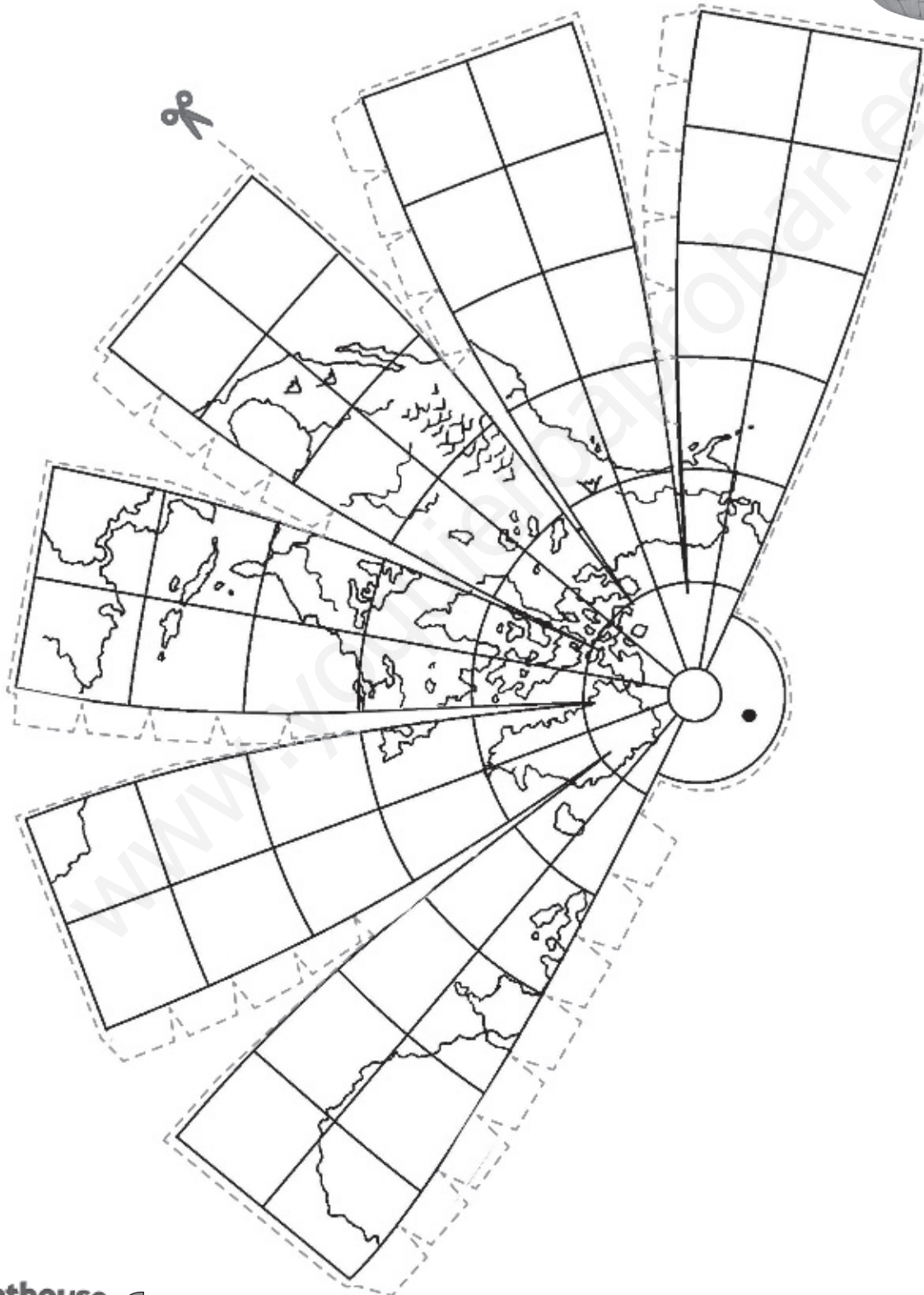

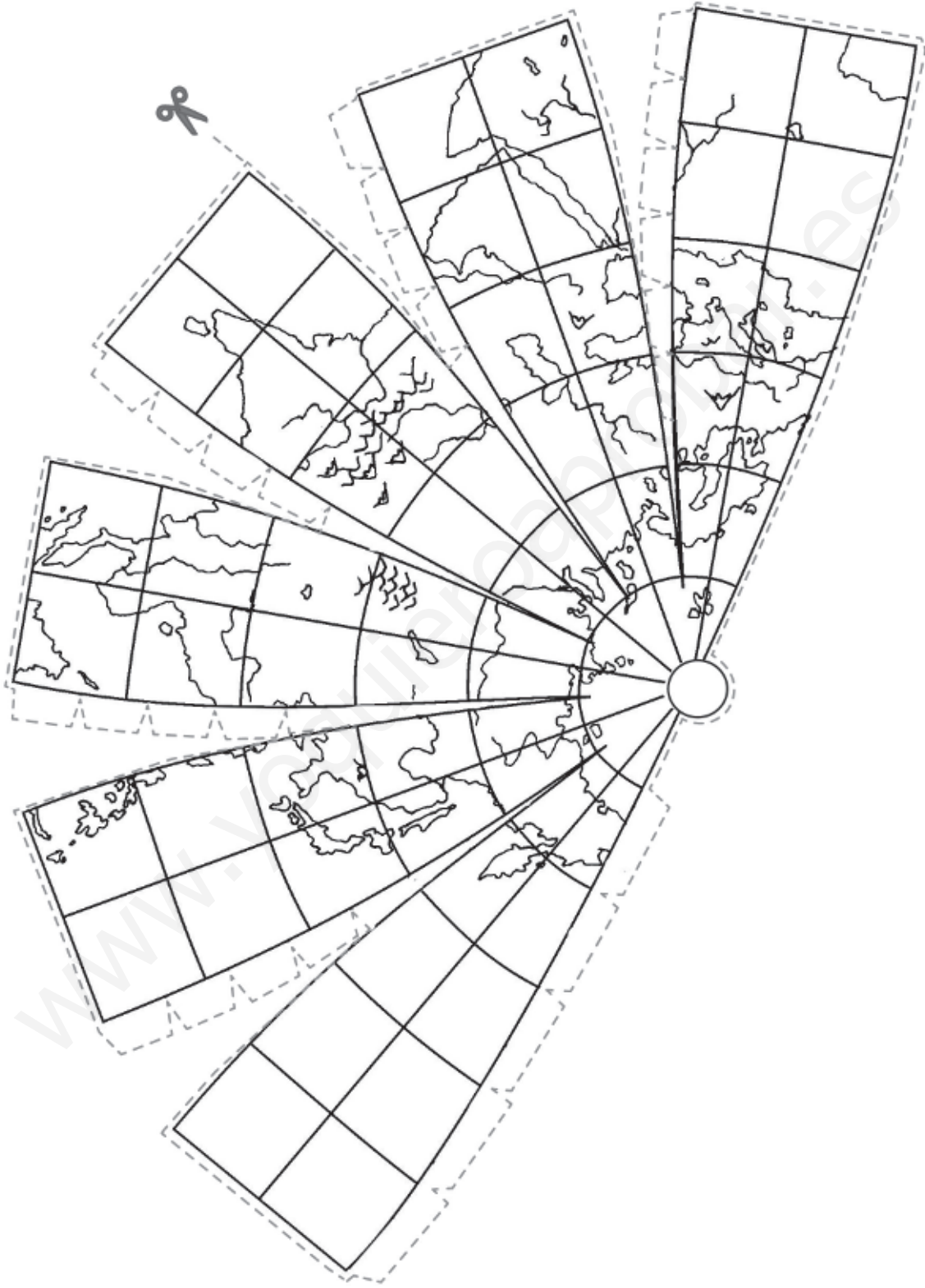

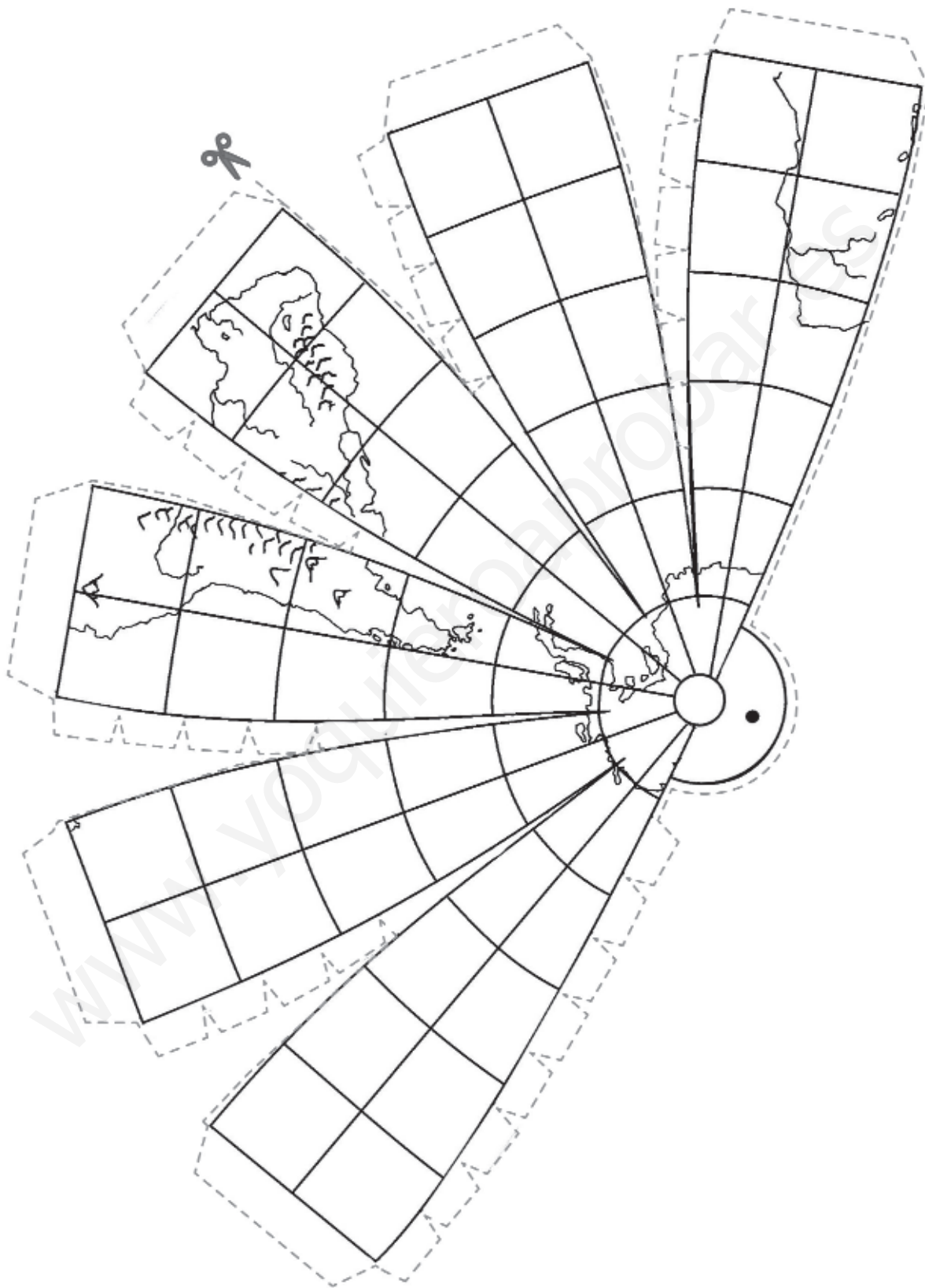

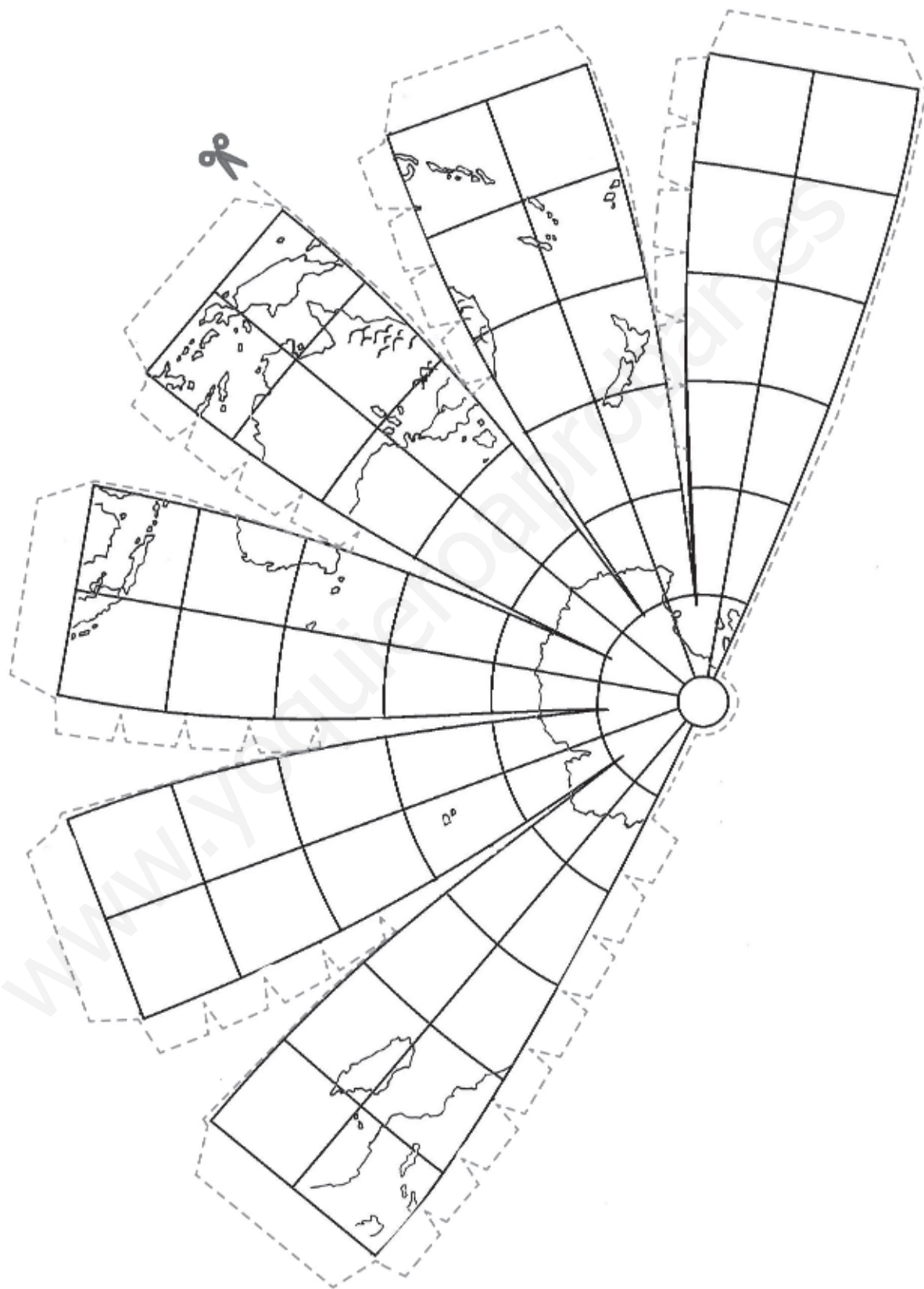



Unit 5 Value

Expressing yourself

⚓ Make an Impressionist painting.   

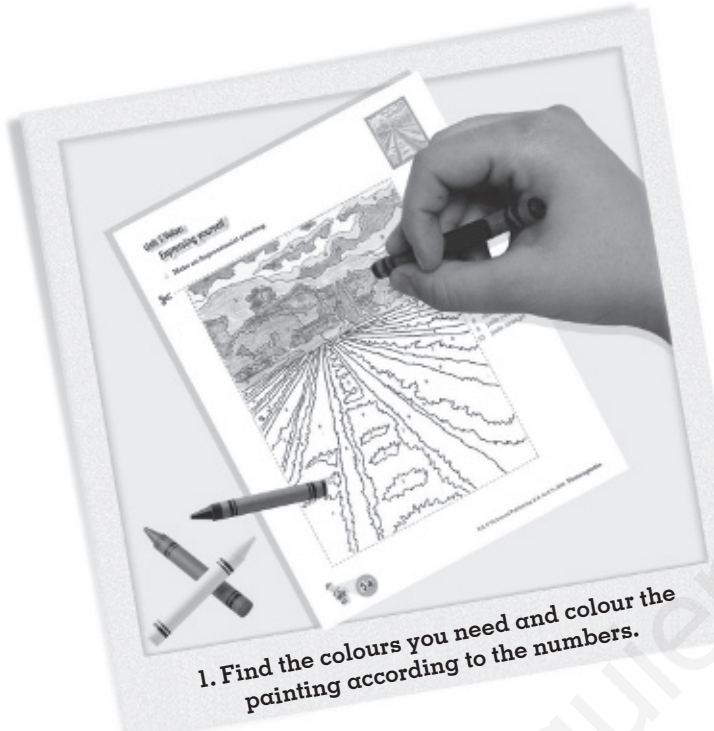
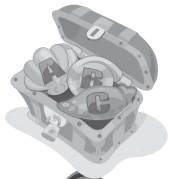

1. Find the colours you need and colour the painting according to the numbers.

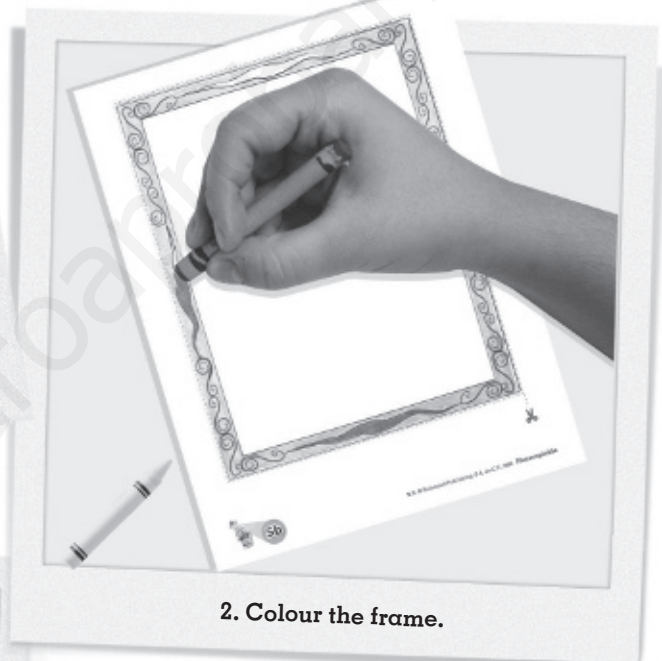

2. Colour the frame.

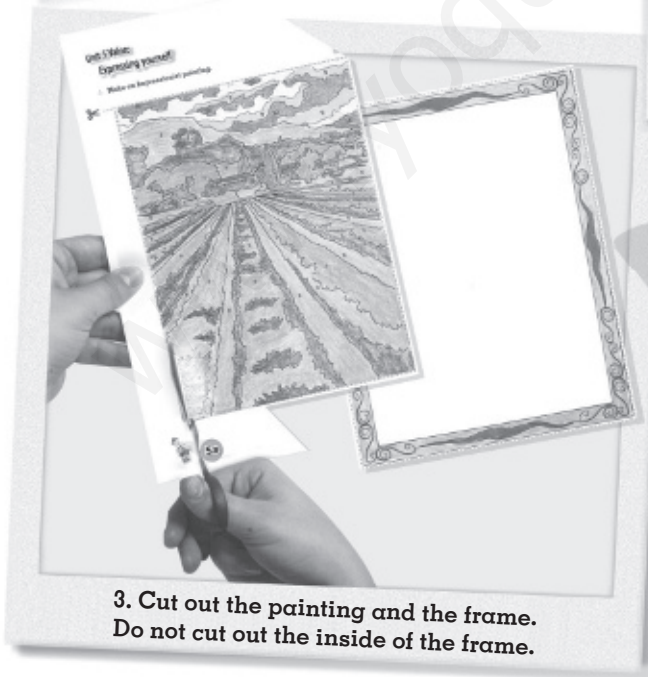

3. Cut out the painting and the frame.
Do not cut out the inside of the frame.



4. Stick the painting into the frame.
Think about how the colours make you feel.



Unit 5 Value

Expressing yourself

✚ Make an Impressionist painting.

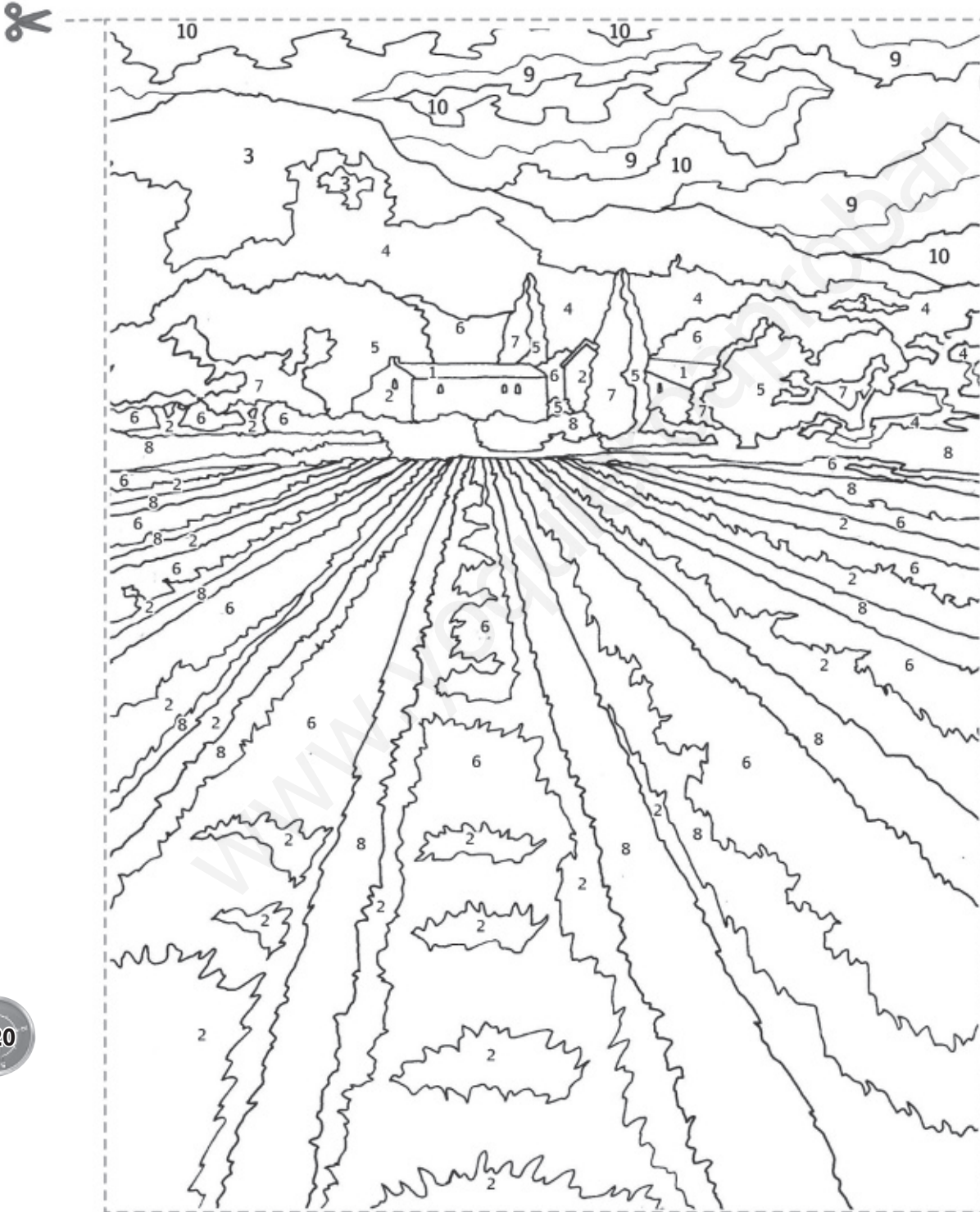
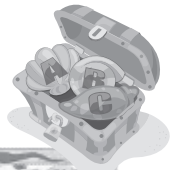

1. dark orange
2. brown
3. pale blue
4. dark blue
5. bright green
6. pale green
7. dark green
8. dark yellow
9. pale yellow
10. pale orange





Unit 6 Value

Playing fair

⚓ Make a mini basketball hoop.

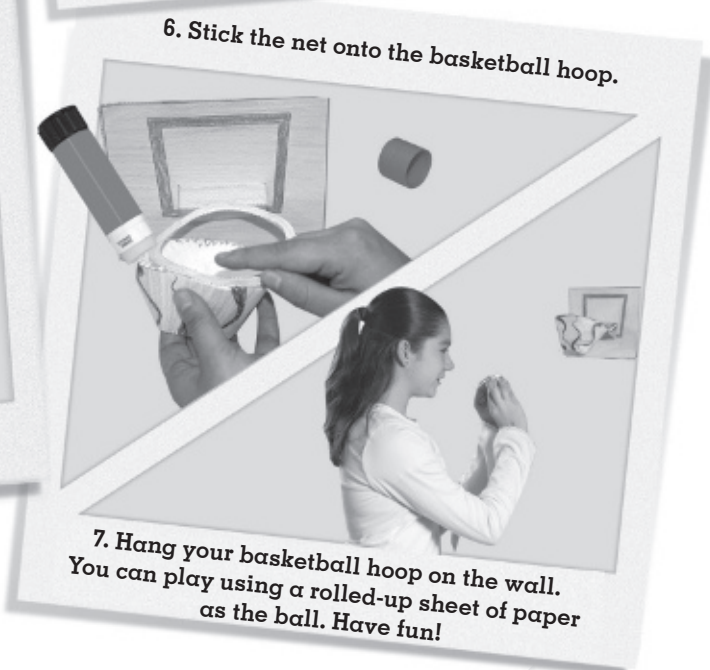
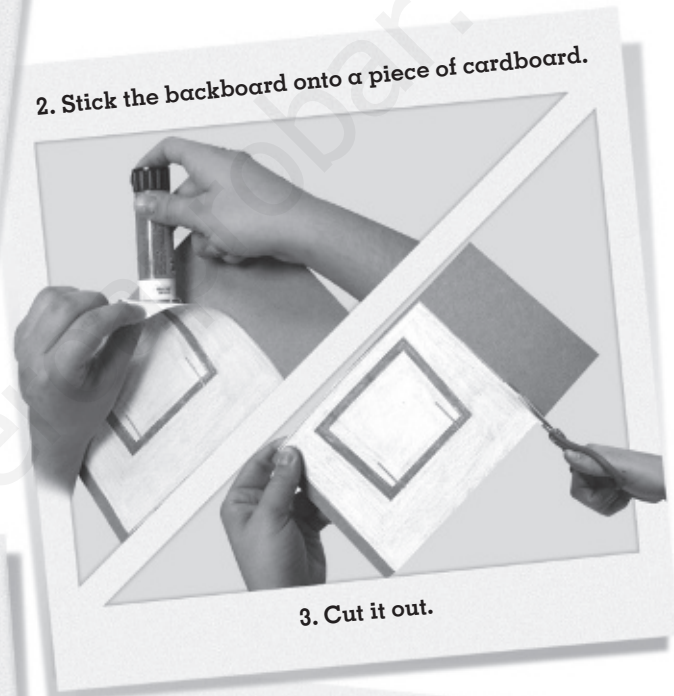
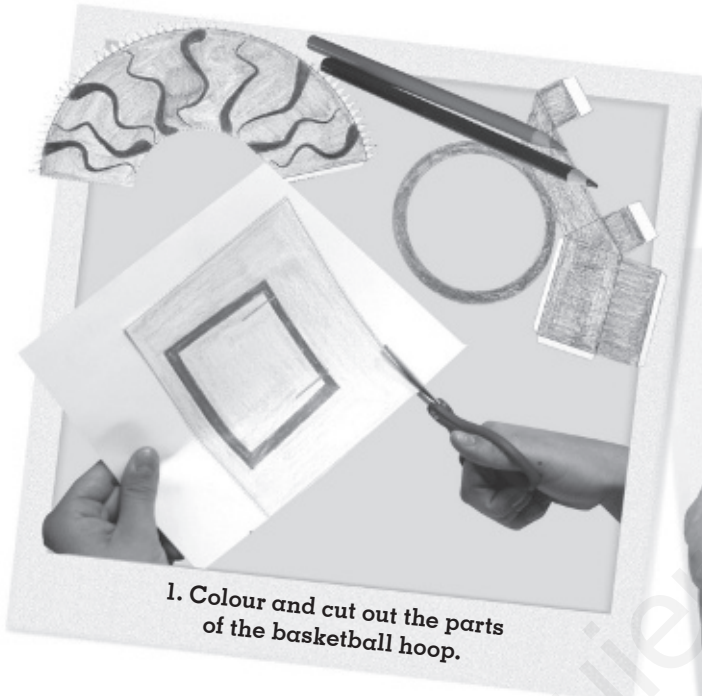



Unit 6 Value

Playing fair

✚ Make a mini basketball hoop.

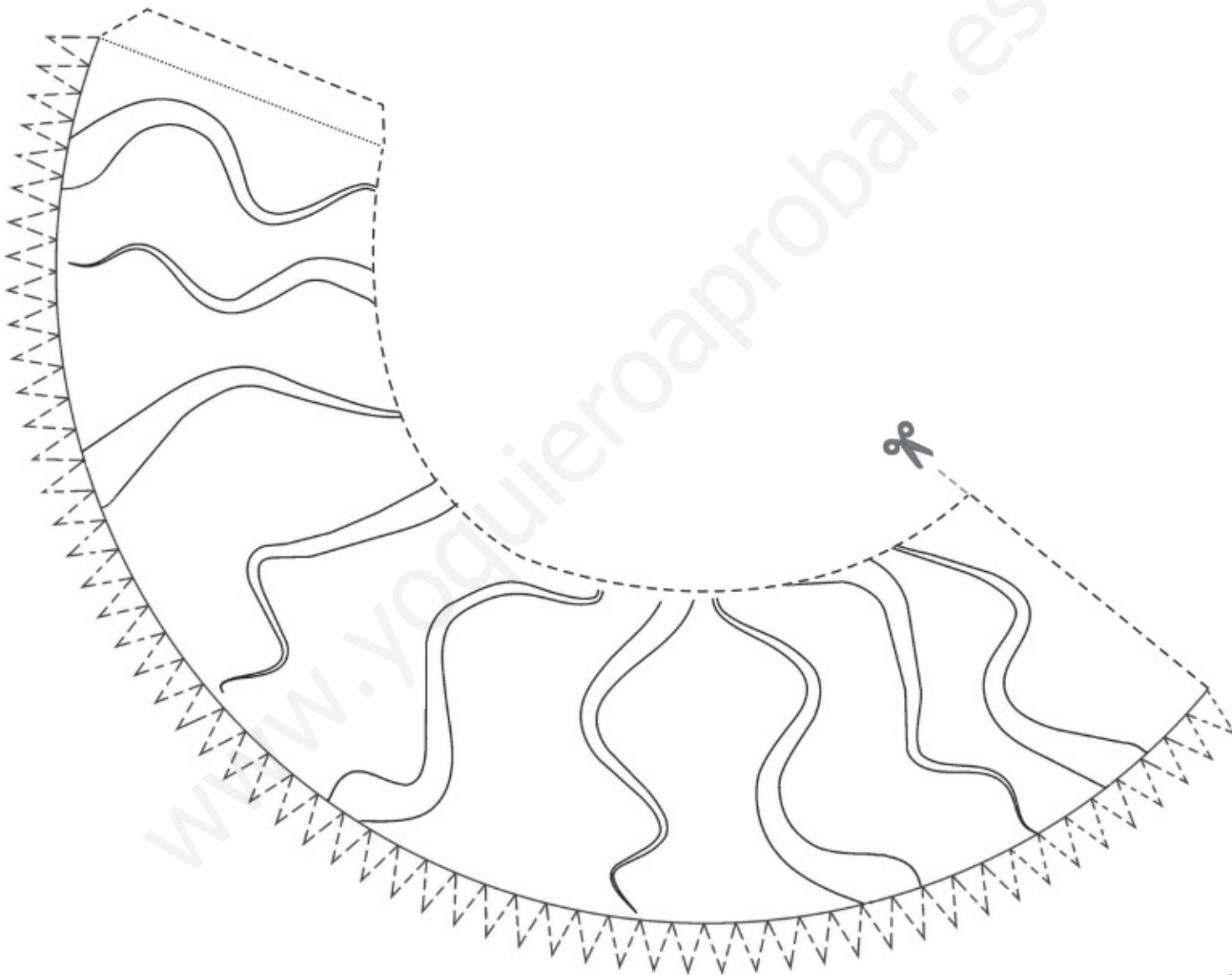
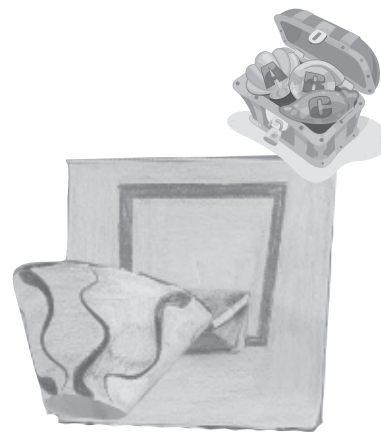

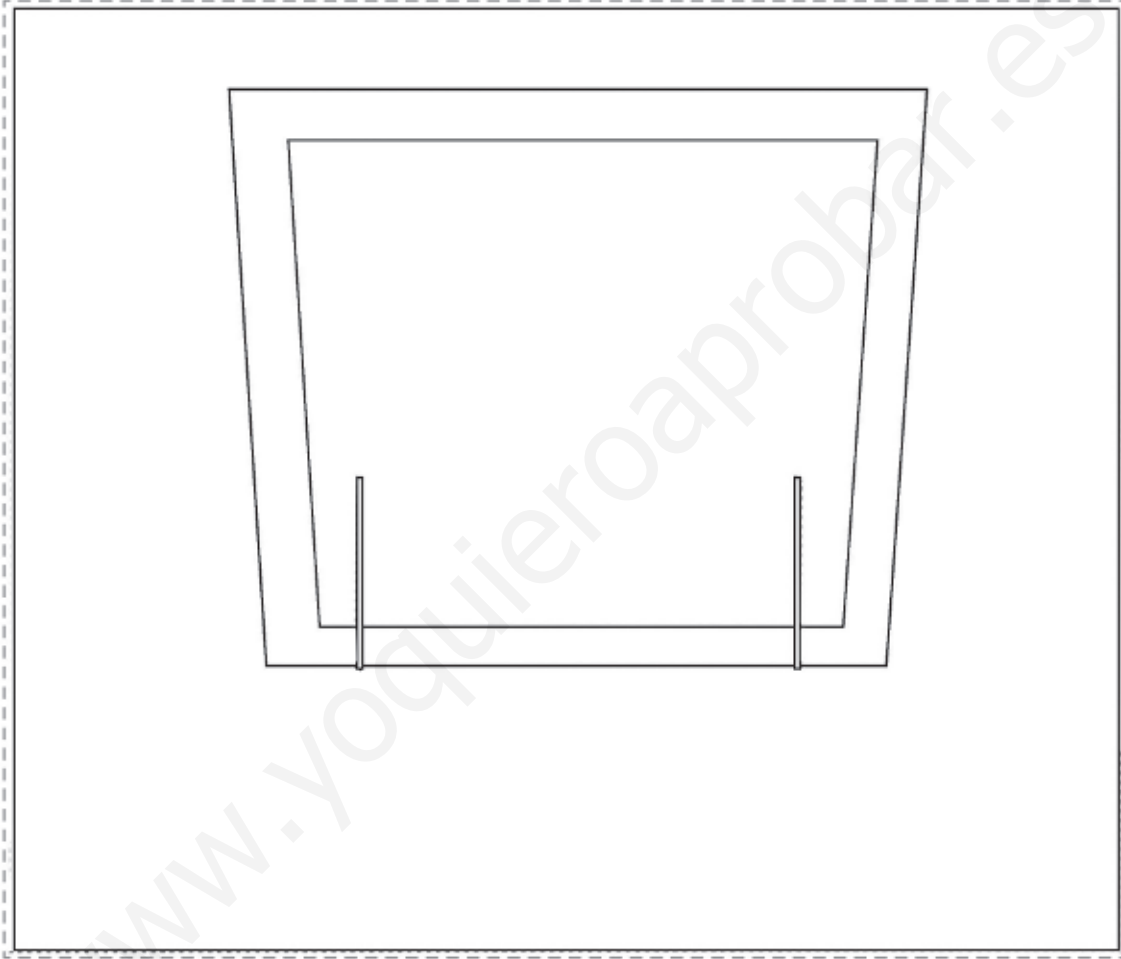

www.yoquieroaprobar.es

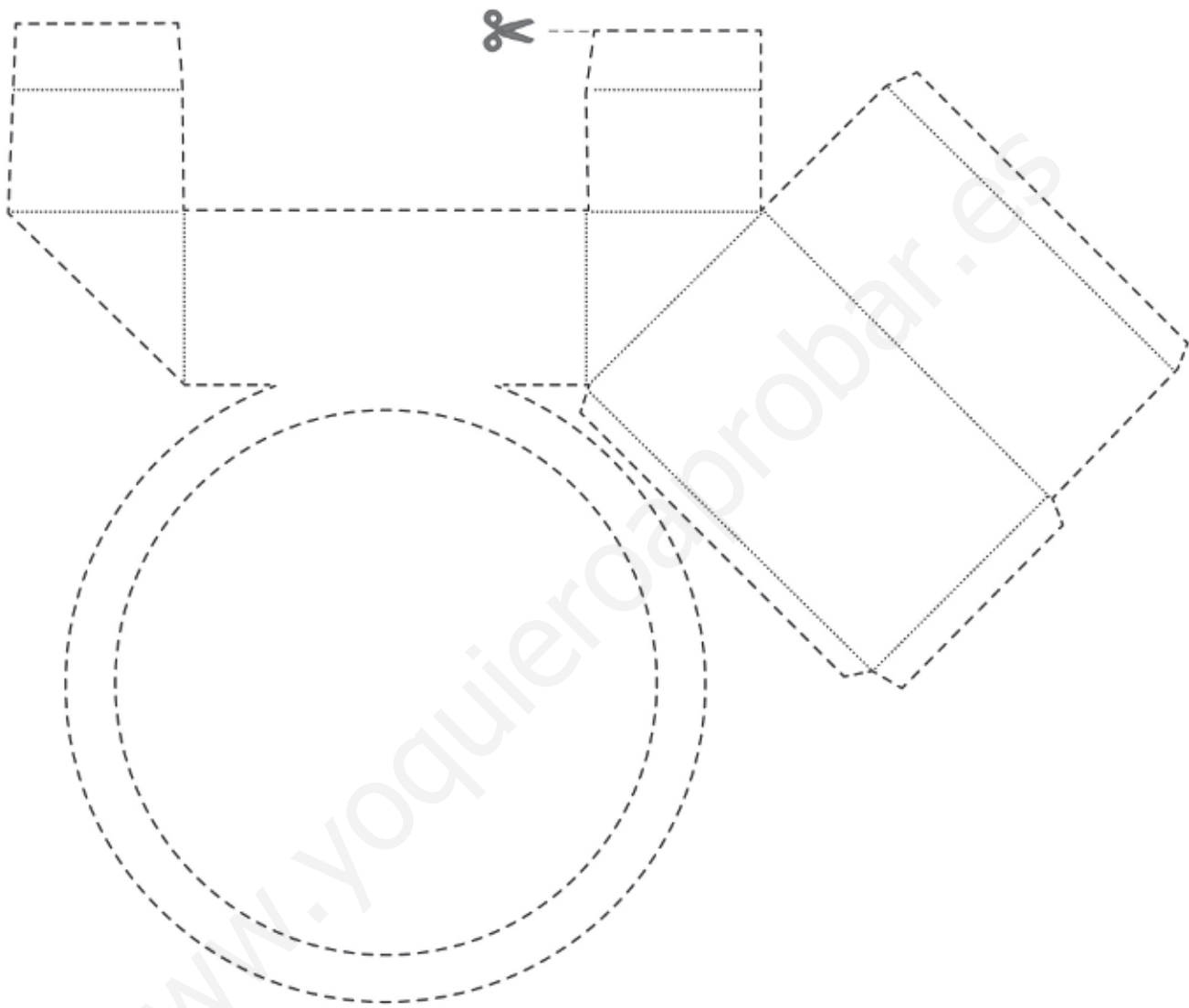



Unit 7 Value

Exercising regularly

⚓ Make an exercise chart.

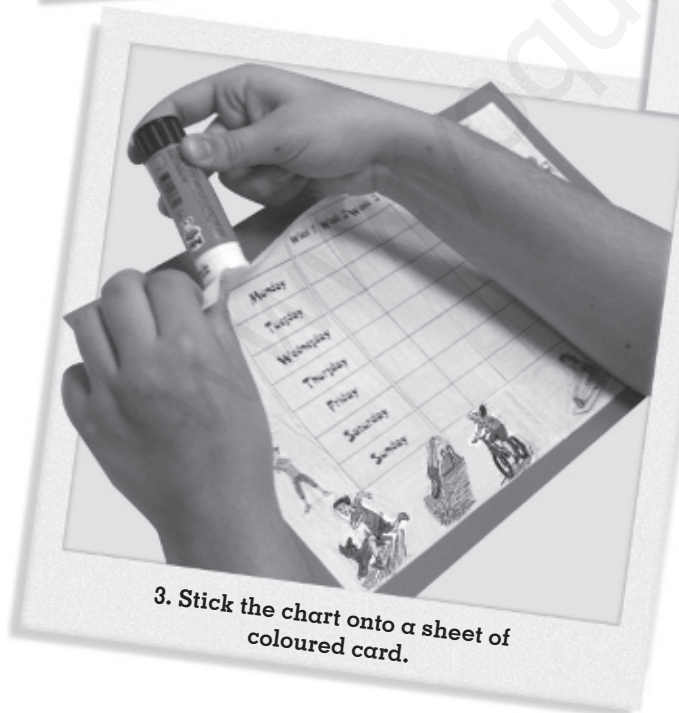



Unit 7 Value

Exercising regularly



✚ Make an exercise chart.



		Week 1	Week 2
	Monday		
	Tuesday		
	Wednesday		
	Thursday		
	Friday		
	Saturday		
	Sunday		
			

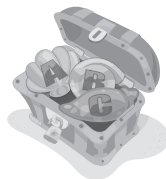

Week 3	Week 4	Week 5





Unit 8 Value

Looking at the positive

✚ Make a newspaper article.

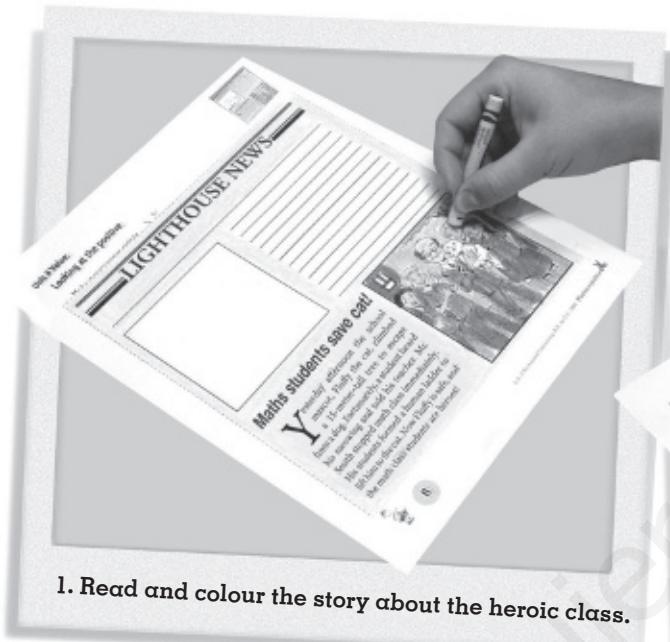
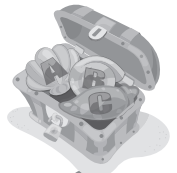

1. Read and colour the story about the heroic class.

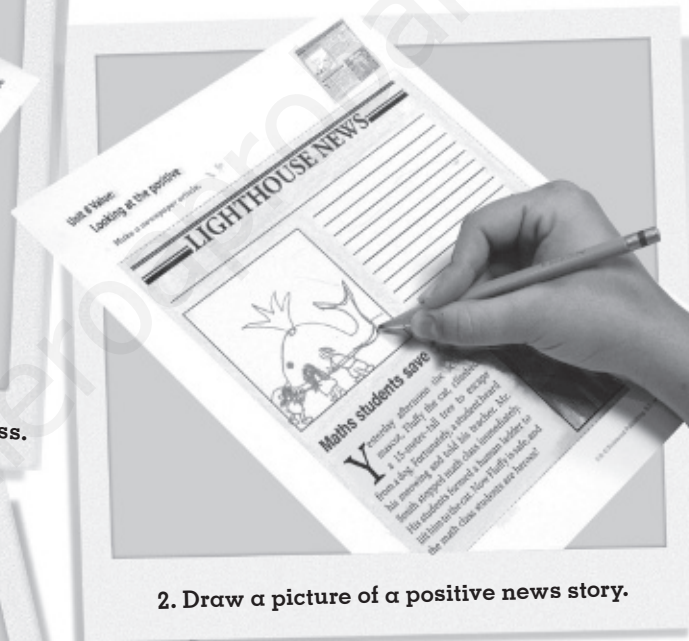

2. Draw a picture of a positive news story.



3. Write a headline for your story and describe what happened.



4. Cut out the newspaper page and hang it up at home.



Unit 8 Value

Looking at the positive

✂ Make a newspaper article. ✂



LIGHTHOUSE NEWS

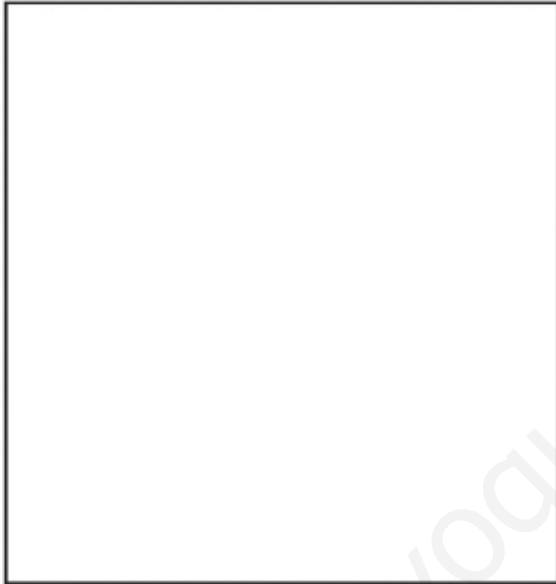

MATHS STUDENTS SAVE CAT!

Yesterday afternoon the school mascot, Fluffy the cat, climbed a 15-metre-tall tree to escape from a dog. Fortunately, a student heard his meowing and told his teacher. Mr. Smith stopped the lesson immediately. His students formed a human ladder to lift him to the cat. Now Fluffy is safe, and the Maths students are heroes!





Unit 9 Value

Doing the right thing

⚓ Make a values chain.



1. Colour and cut out the pictures.



2. Fold each picture in half.

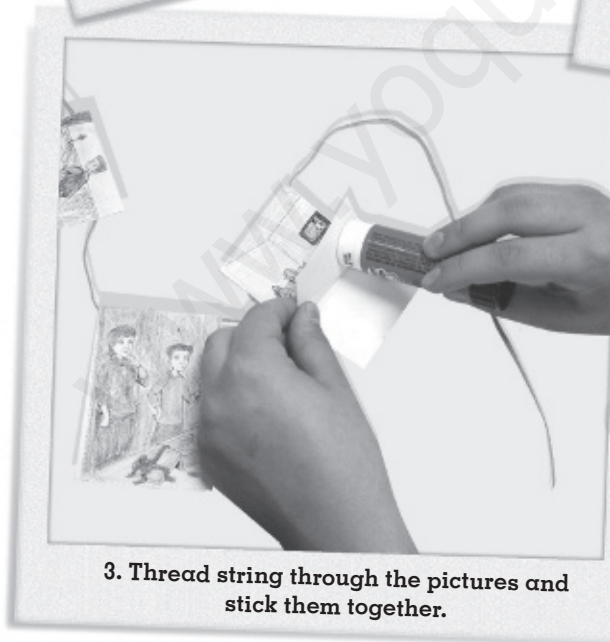

3. Thread string through the pictures and stick them together.

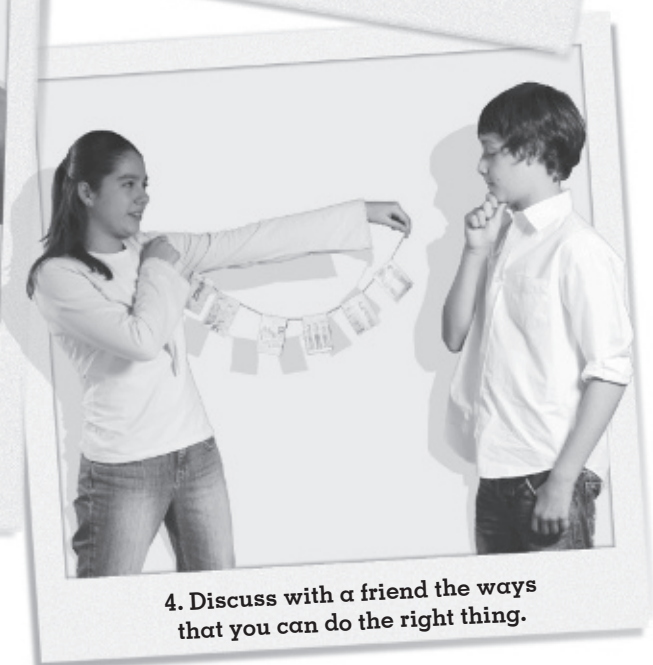

4. Discuss with a friend the ways that you can do the right thing.



Unit 9 Value

Doing the right thing

✂ Make a values chain.

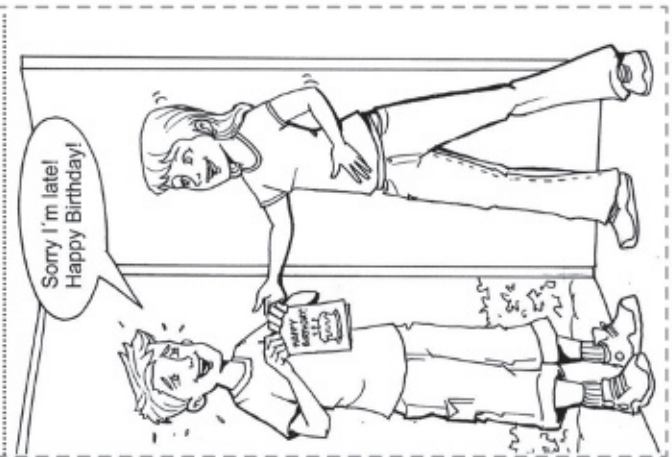
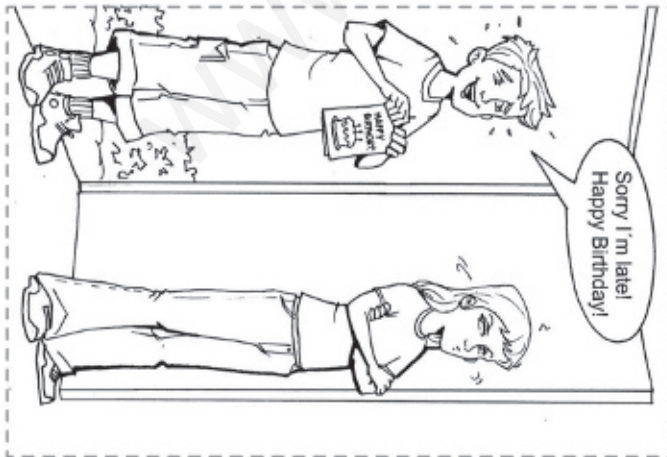
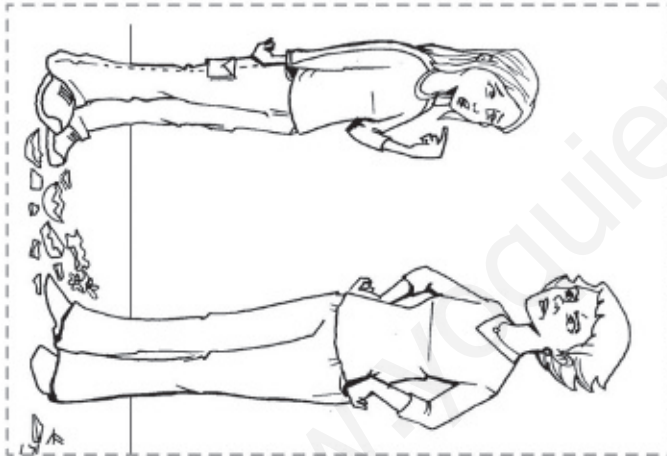
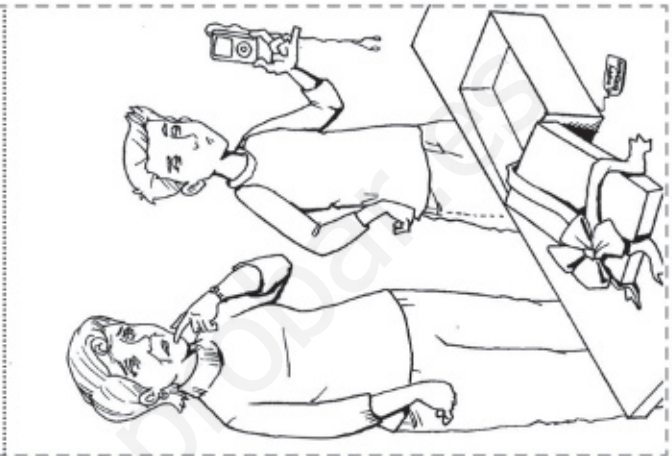

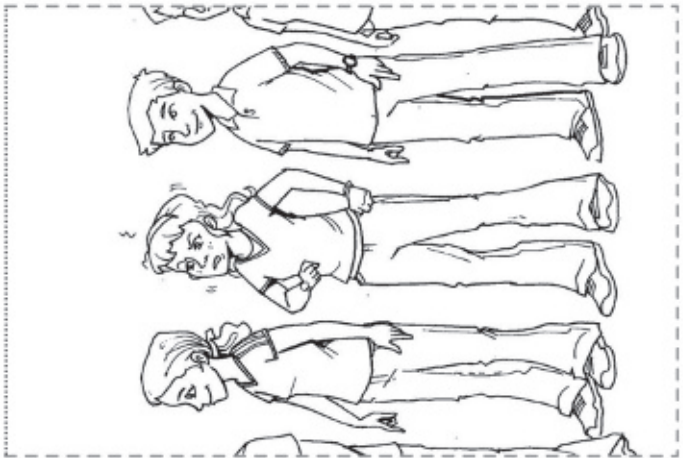
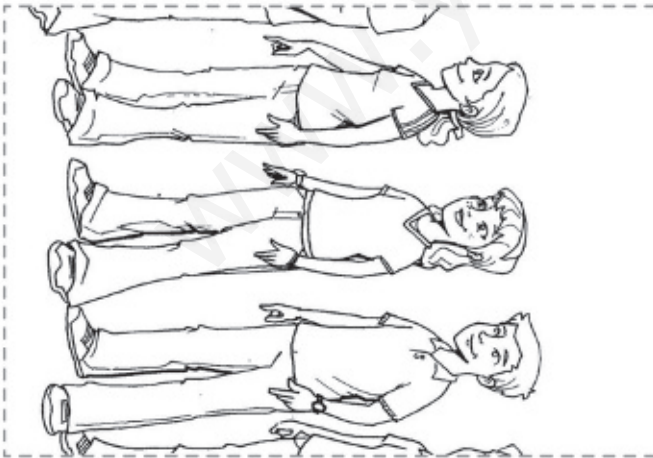
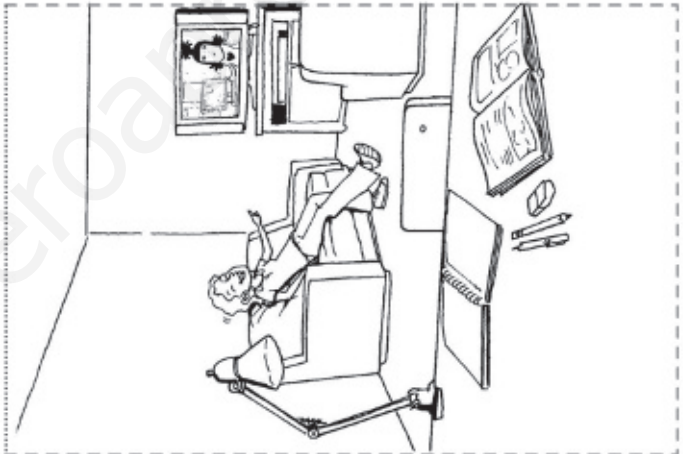
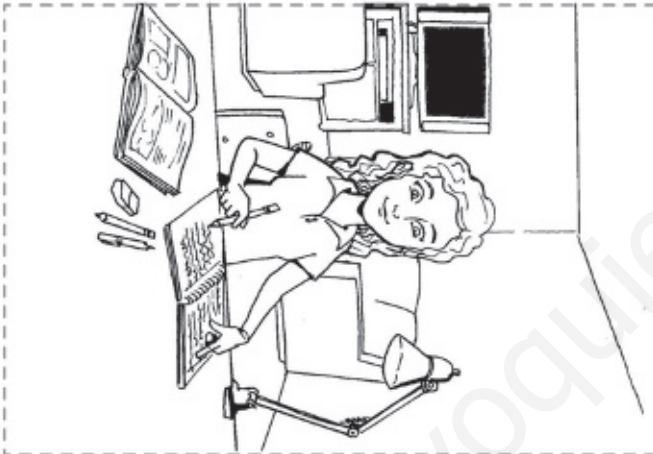
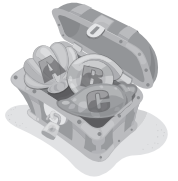



Vocabulary Lists



* Vocabulary Lists

Unit 1 and Unit 2	136
Unit 3 and Unit 4	137
Unit 5 and Unit 6	138
Unit 7 and Unit 8	139
Unit 9	140



www.yoquieroaprobar.es





Vocabulary Lists

Unit 1

Beach

- coconut _____
- coral _____
- oyster _____
- palm tree _____
- pearl _____
- seaweed _____
- shade _____
- shelter _____
- shipwreck _____
- sunburnt _____

Senses

- hearing _____
- sight _____

- smell _____
- taste _____
- touch _____

Adjectives 1

- beautiful _____
- creamy _____
- crunchy _____
- disgusting _____
- fresh _____
- loud _____
- quiet _____
- rotten _____
- rough _____
- slimy _____
- smooth _____
- sweet _____

Unit 2

Musical instruments

- clarinet _____
- drums _____
- flute _____
- keyboard _____
- saxophone _____
- trombone _____
- trumpet _____
- tuba _____
- violin _____

Musical genres

- classical _____
- country _____
- heavy metal _____
- jazz _____
- pop _____
- rap _____
- rock _____
- samba _____

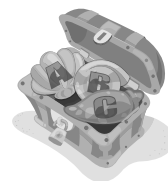

Unit 3

Film jobs

- actor _____
- actress _____
- cameraman _____
- extras _____
- film director _____
- make-up artist _____
- producer _____
- scriptwriter _____
- stuntman _____

Film features

- acting _____
- costumes _____
- dubbing _____
- original version _____
- plot _____
- soundtrack _____
- special effects _____
- subtitles _____



Unit 4

Pollution

- exhaust fumes _____
- landfill _____
- litter _____
- oil spill _____
- sewage _____
- smog _____
- smoke _____
- toxic waste _____

Collocations 1

- eat organic food _____
- pick up litter _____
- plant trees _____
- produce clean energy _____
- put up solar panels _____
- save water _____
- use biodegradable products _____
- use public transport _____

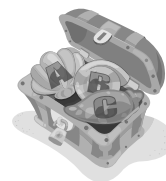

Unit 5

Art supplies

- canvas _____
- digital camera _____
- easel _____
- flash _____
- lens _____
- oil paints _____
- pastels _____
- spray paint _____
- watercolours _____

Art forms

- abstract _____
- collage _____
- landscape _____
- mosaic _____
- mural _____
- portrait _____
- self-portrait _____
- still life _____

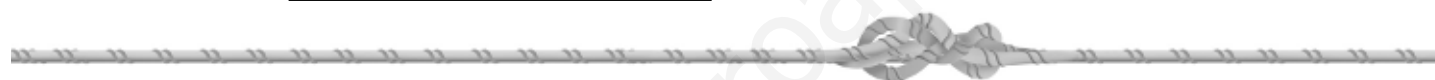

Unit 6

Sports facilities

- American football field _____
- baseball pitch _____
- basketball court _____
- bowling alley _____
- boxing ring _____
- football pitch _____
- golf course _____
- hockey arena _____
- swimming pool _____
- tennis court _____

Sports equipment

- baseball glove _____
- basketball hoop _____
- diving board _____
- goal _____
- golf club _____
- helmet _____
- hockey puck _____
- hockey stick _____
- tennis racket _____
- volleyball net _____



Unit 7

The body

blood _____

bones _____

brain _____

heart _____

intestines _____

kidneys _____

liver _____

lungs _____

muscles _____

skin _____

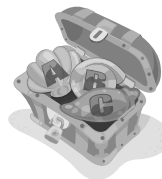

Verbs

chew _____

cough _____

have the hiccups _____

scratch _____

sneeze _____

snore _____

swallow _____

yawn _____

Unit 8

TV programmes

cartoon _____

documentary _____

drama _____

news _____

soap opera _____

talk show _____

traffic report _____

quiz show _____

weather report _____

The news

breaking news _____

exclusive interview _____

latest headlines _____

live coverage _____

newsreader _____

overseas correspondent _____

special report _____



Unit 9

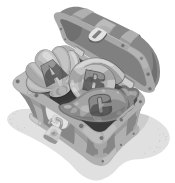

Personal qualities

courage _____

forgiveness _____

honesty _____

loyalty _____

patience _____

responsibility _____

Adjectives 2

courageous _____

forgiving _____

honest _____

loyal _____

patient _____

responsible _____

Collocations 2

cheat in an exam _____

get even _____

look up to _____

stand up for _____

tell a lie _____

tell on someone _____

tell the truth _____





Young Learner & Trinity Exam Tips



* YLE

Tips for YLE. 142

* Trinity

Tips for Trinity 142

Initial Stage Example questions 143

Elementary Stage Example questions 143

www.yoquieroaprobar.es





Young Learner & Trinity Exams

Tips for the Test - YLE and Trinity

The **Cambridge Young Learner** exams are designed for children aged from 7 to 12 years old. They are tested normally in their own school environment or an exam centre, and the exams all follow the same format. There are three levels: Starters, Movers and Flyers. In terms of grammar and lexis, the Flyers level is on par with the KET exams. The difference is that, unlike the exams for older students, children cannot fail the YLE. Every participant is given a diploma with badges in Reading, Writing, Listening and Speaking. The badges are coloured in depending on the success of the candidate.

Exams follow a very set format. The children never write on the exam papers, rather they answer on an answer sheet, usually with one word answers. They are tested in groups, except for the Speaking session, where the test is given individually.

The Lighthouse YLE CD-ROM includes three complete tests. These can be printed out in colour and used for classroom practice; one set can be used many times. The children write their answers on a piece of paper except for the last page of the Listening exams, which is used for colouring and therefore can only be used once.

Tips

- When doing the practice exams it is best to recreate similar circumstances as when the students will do the exam themselves, allow them the same amount of time, and have them practise exam techniques.
- The ESOL web site has an abundance of exam tips as well as more practice activities and information about the exams.
- The interactive activities on the CD-ROM are divided into the different sections of the exams. This way the teacher may choose to practice the same exam question in various exams or practise once complete exam, or pick and choose activities from different exams.

Trinity College London, Graded Examinations in Spoken English

The Trinity Examinations in Spoken English are one-to-one oral examinations with a native English speaking Trinity examiner, which test a student's speaking and listening skills. The exams provide an official recognition of a student's level of spoken English and are accepted by universities and employers worldwide. Candidates must be aged 7 or over.

The examinations are divided into a series of 12 oral exams which test the student's general conversation and ability to discuss prepared topics. The exam grades range from absolute beginner level to near native fluency.

Apart from being a recognised meter of a student's skills in English, the examination also works as a motivational tool encouraging students to practise and try to communicate in English.

Tips

- In each English lesson, ask general questions such as *What day is it today? What's the weather like today? Is it spring or summer? How old are you?*
- Encourage full answers whenever asking questions. *T: What day is it today? SS: Tuesday. T: It's Tuesday.*
- When asking questions, if a child does not know the answer, encourage them to say "I don't know" or "I can't remember" or "I'm sorry, I don't know the word in English", rather than remaining silent or saying "errr".
- Make question practice fun. Do it in the form of a team quiz and award points. Or ask questions at the end of a lesson, whoever answers correctly can line up first.
- Practise for the exam in regular, short sessions so candidates become more confident with the style of question and can answer more rapidly and naturally.

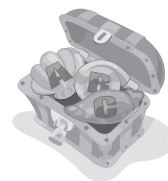

- When choosing a grade for candidates, consider the child's personality as well as their level of English. A shy child with a good level of English, may not do as well as a more outgoing child who speaks more spontaneously.
- Encourage the children to ask questions too. From Level 2 onwards they are expected to ask the examiner questions.

Initial Stage (Grades 1, 2 and 3)

Example questions

Grade 1

Hello, good morning, goodbye

Point to / show me (the red crayon, your nose, my shirt, the dog, the big cow...)

Go to / touch (the window, the door...)

Stand up, please.

What's your name?

How old are you?

What colour is that?

And this one?

What's this?

What are they?

How many cats are there in this picture?

Look, I have a (blue shirt, brown trousers and black shoes). And you?

Grade 2

Have you got any brothers or sisters?

What's his name?

Put the red pen on the green book.

Where's the rubber?

Where do you come from?

Tell me about your house.

Do you have any pets?

What day is it today?

Is it March or April?

How many children are there in your class?

Look at this picture, what is this woman wearing?

Grade 3

Where do you live?

What's the weather like?

Is it raining now?

What day was it yesterday?

What can you see in this room?

Tell me about your mother.

What's the date today?

What time is it?

What do you study at school?

Who is your favourite teacher?

Describe your best friend.

How do you get to your classroom from here?

Can you ride a horse?

Look at this picture, what are these children doing?

Where are your friends now?

Have you got any hobbies?

What do you do on Saturdays?

Elementary Stage (Grades 4, 5 and 6)

This is a 10 minute exam which has 2 phases; a discussion on the candidate's pre-prepared topic and the conversation. Children should try to maintain a fluid conversation rather than just answering the examiner's questions.

Tips for preparing the topic

- Children should choose something that they are genuinely interested in and can talk easily about, (a hobby, pet, recent holiday...).
- They should collect all necessary photos or pictures well before the exam to give them time to plan the points and practice what to say.
- Children should not learn their topic by heart as they must speak naturally and spontaneously in the exam.
- Allow children the possibility of presenting their topic to the class and answering their questions to give them more confidence.
- The child should prepare several questions to ask the examiner related to their topic.
- Make a photocopy of the Topic Form for each student. Check that their information and spelling is correct before giving them the real Topic Form to complete.

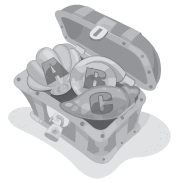

Example questions

Grade 4

- What are you going to do this weekend?
- Where did you go on holiday last year?
- When did you start in this school?
- How often do you go to the cinema?
- Tell me about your hobbies.
- Did you watch any TV last night?

Grade 5

- How long have you been (playing basketball)?
- Which do you prefer, reading books or watching films?
- How are you going to celebrate your birthday?
- What is the most important festival here?
- What sort of TV programmes do you watch?
- Which is quicker, a car or a bike?

Grade 6

- Do you think these clothes are fashionable?
- Which countries would you like to visit?
- What kind of shopping do you do?
- If it rains this weekend, what will you do?
- What do you do to keep healthy?
- Tell me about some of your school rules.