



Illegible text above the title

ATTENZIONE

3

Illegible text below the number



Illegible text at the bottom

RECONOCIMIENTO DE PROPIEDADES

Pinta los objetos **redondos**.

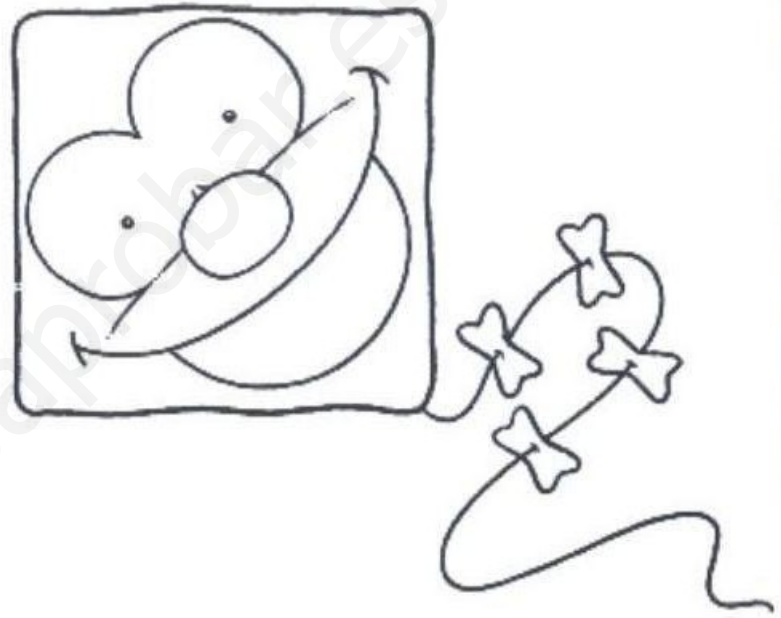
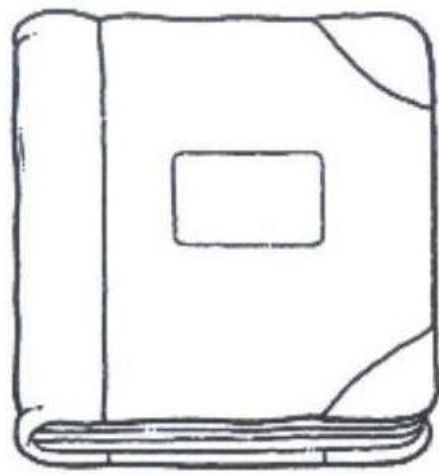



RECONOCIMIENTO DE PROPIEDADES

Pinta los objetos **cuadrados**.

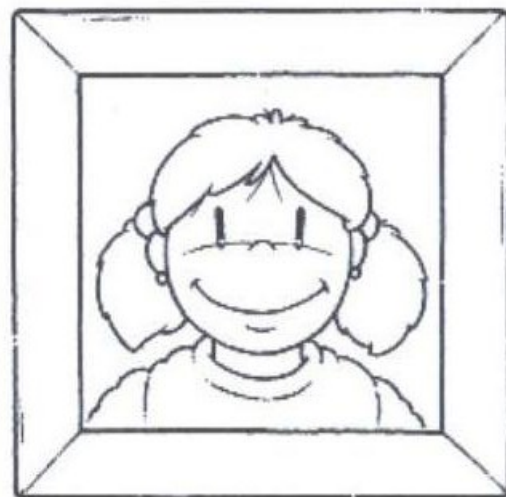
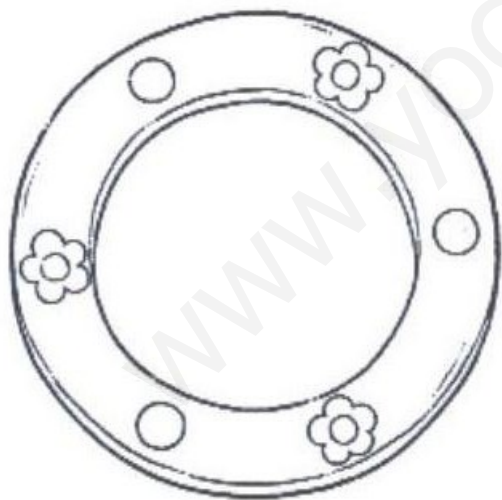
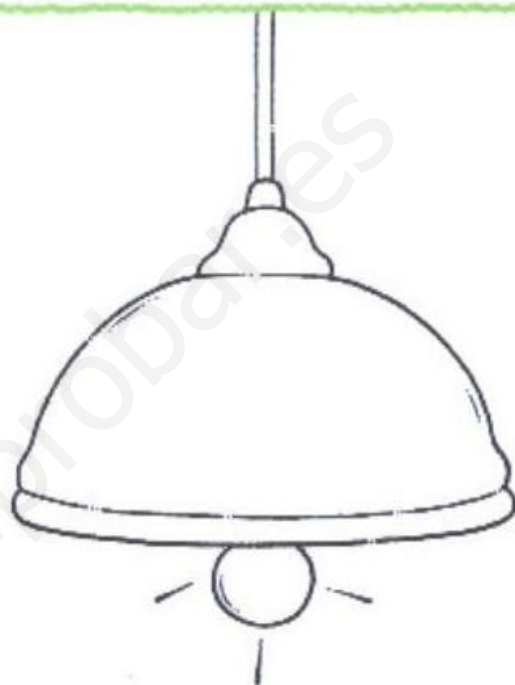
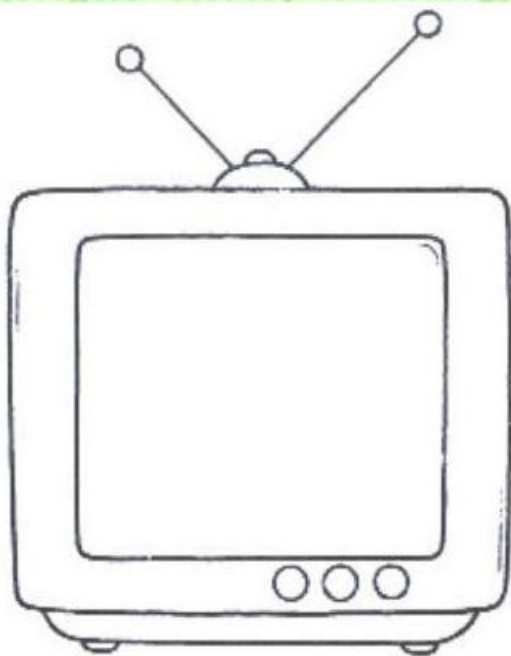

DIBUJOS INCOMPLETOS

Dibuja lo que le falta a cada uno de estos objetos.

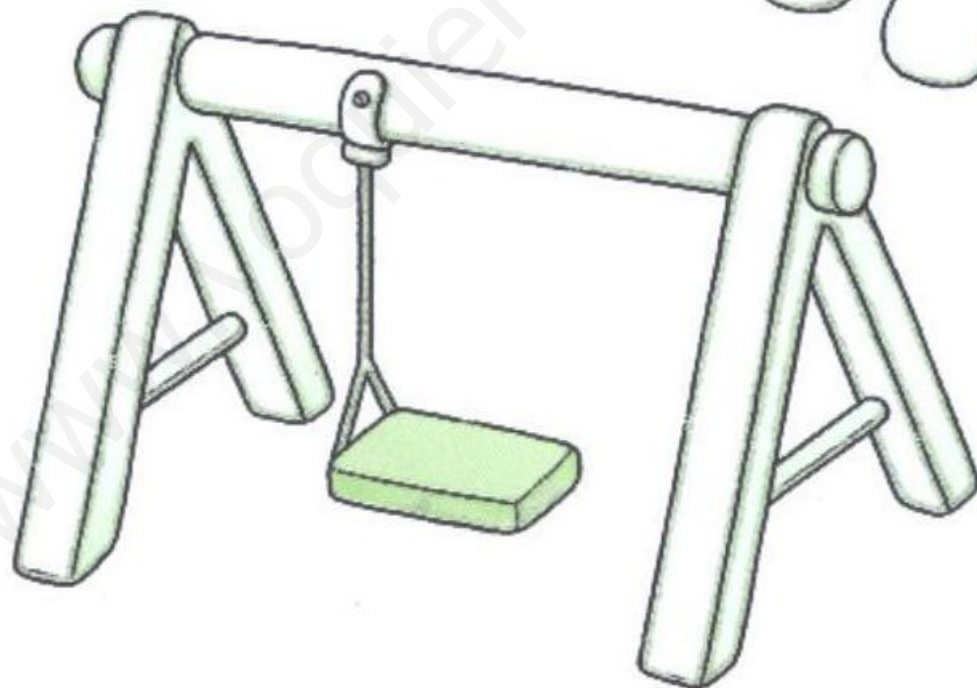
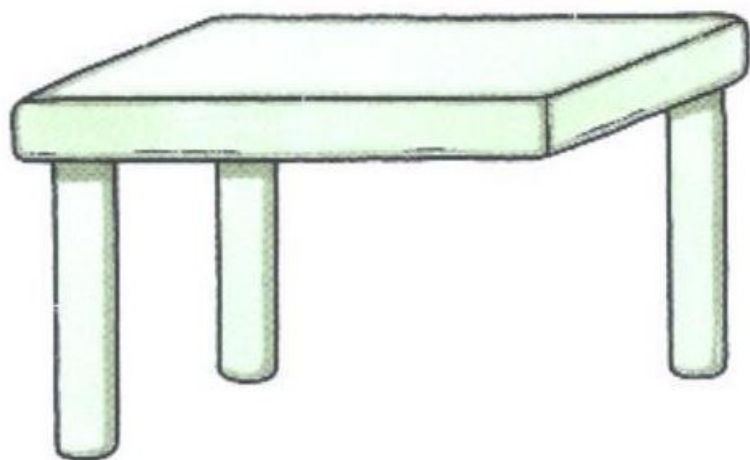

OBJETOS ESCONDIDOS

Encierra los objetos del dibujo que son como los tres modelos.

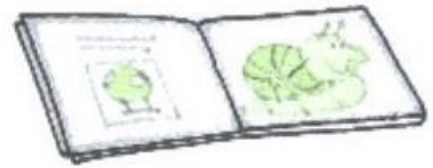



RECONOCIMIENTO DE PROPIEDADES

Pinta de color **azul** las pelotas **grandes**. Tacha las pequeñas.



yoquieroaprobar.es

DIBUJOS INCOMPLETOS

Dibuja lo que le falta al auto. Píntalo.





OBJETOS ESCONDIDOS

Pinta el dibujo. Encierra lo que perdió Caperucita.





SEMEJANZAS Y DIFERENCIAS

Encierra el dibujo igual al modelo.

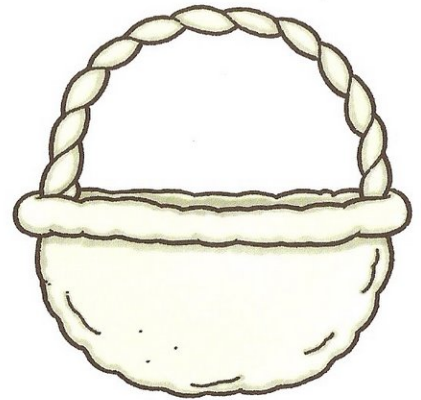
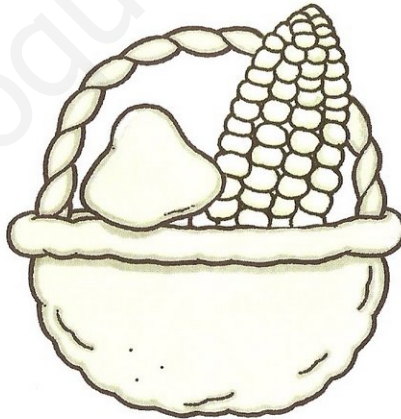
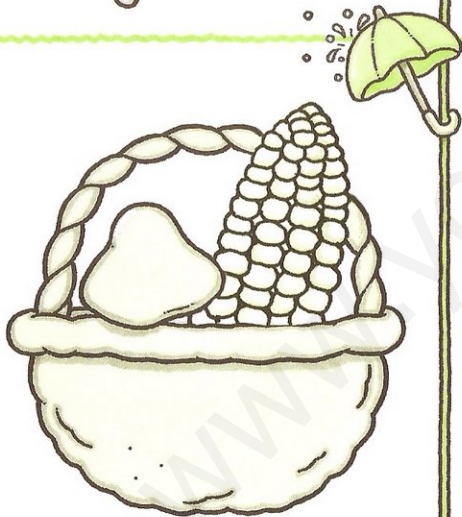
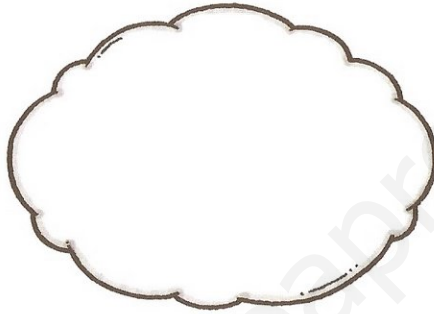
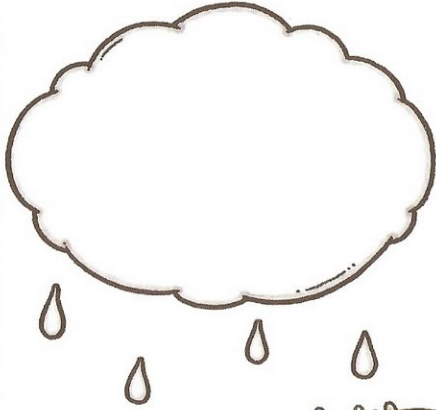



DIBUJOS INCOMPLETOS

Completa los dibujos. Píntalos.

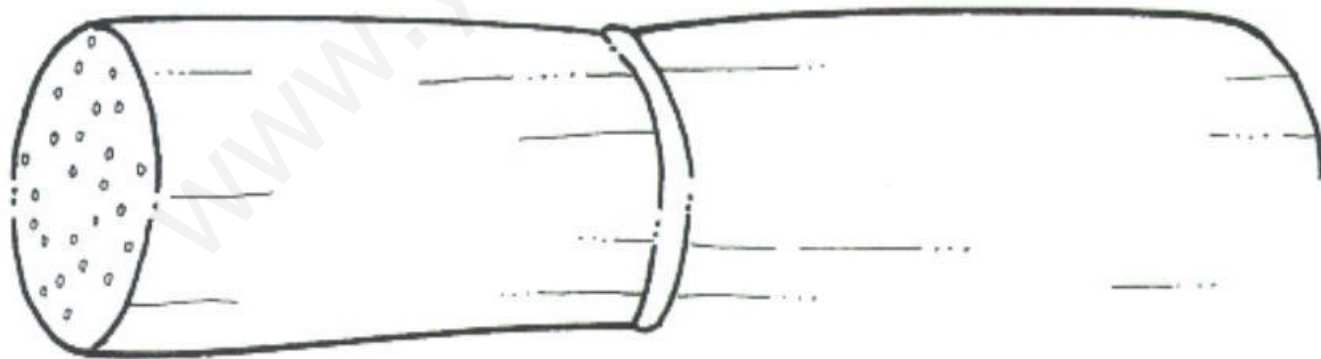
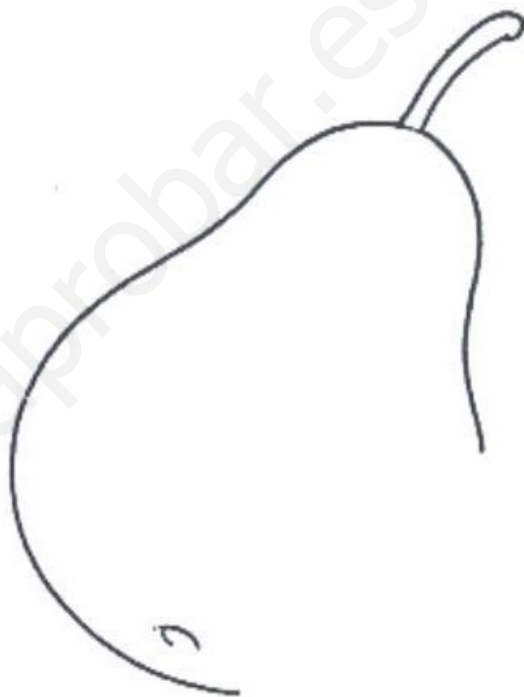

SEMEJANZAS Y DIFERENCIAS

Une con flechas las figuras iguales. Pinta.





FIGURA - FONDO

Busca la manzana y píntala.



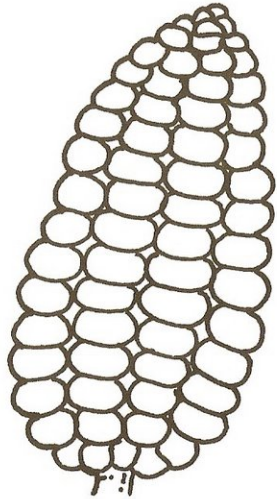
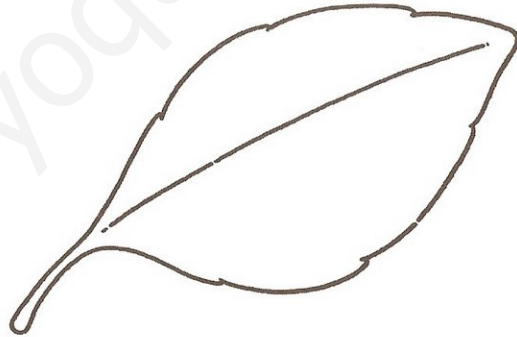
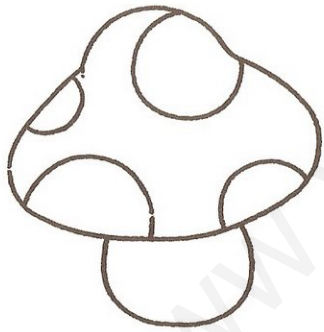
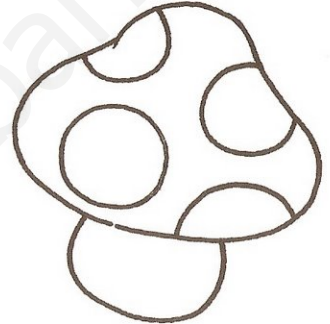
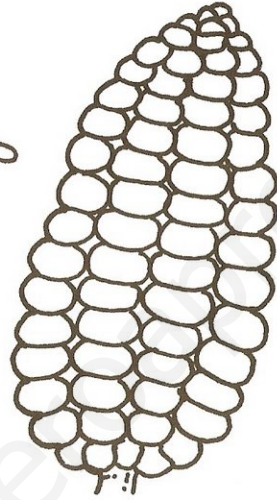
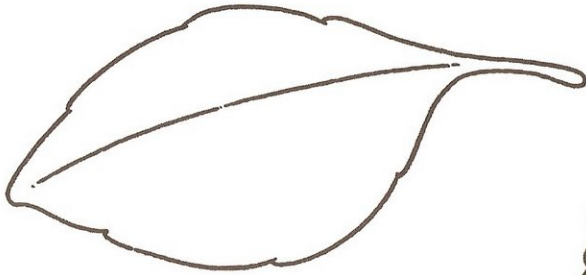
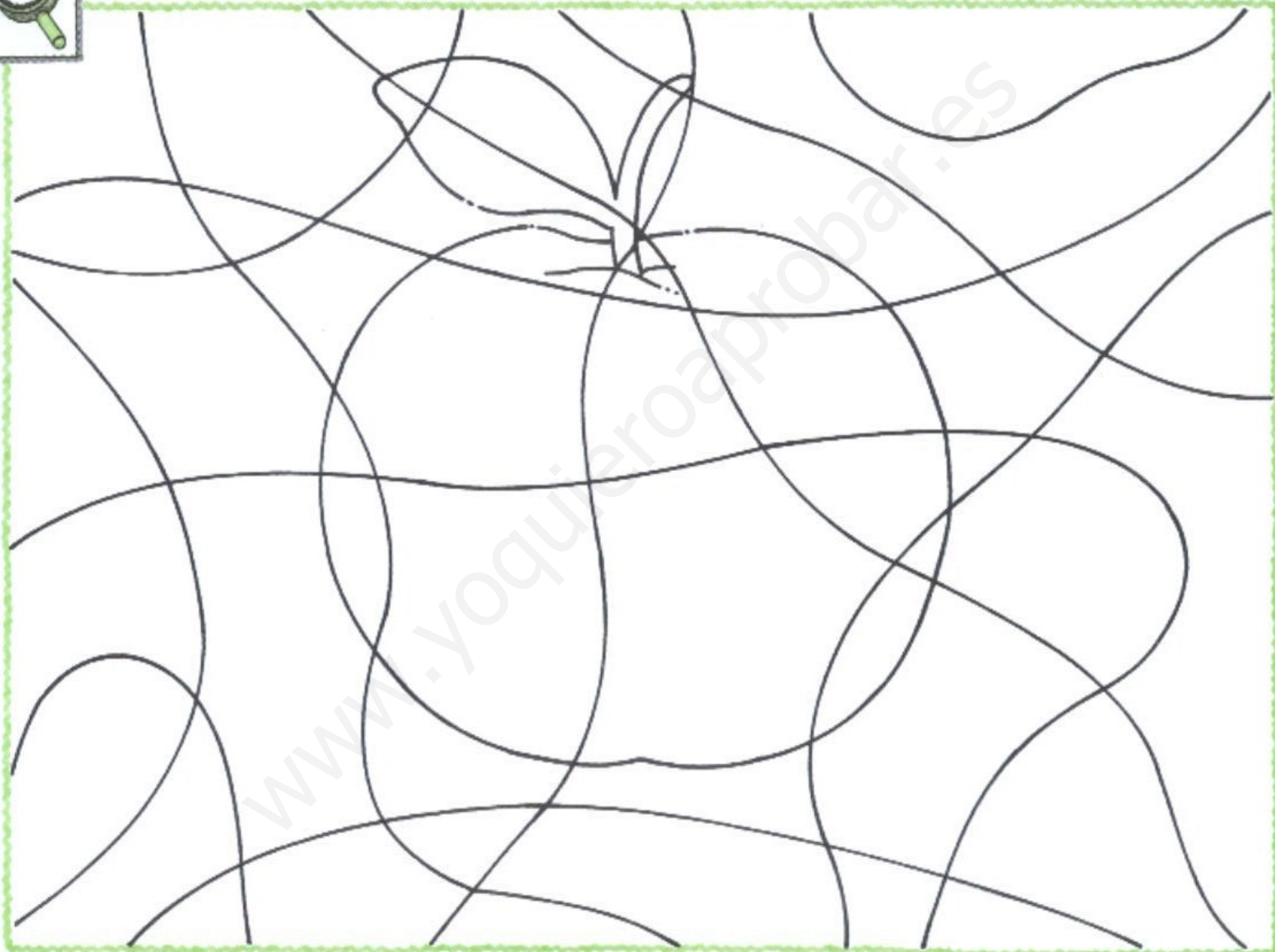

RECONOCIMIENTO DE PROPIEDADES

Pinta los **cuadrados** y pon un punto en los **círculos**.

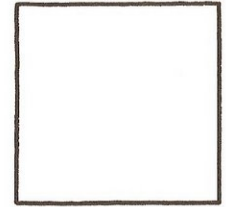
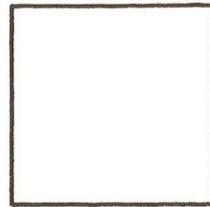
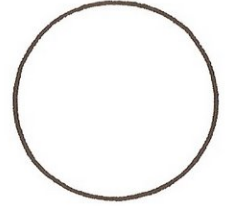
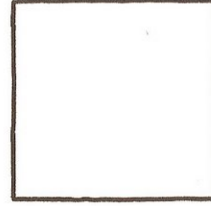
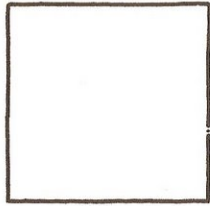
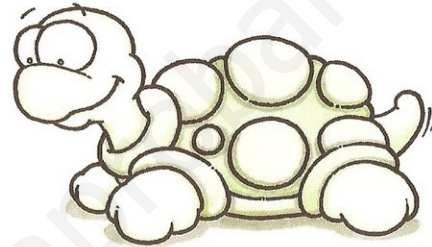
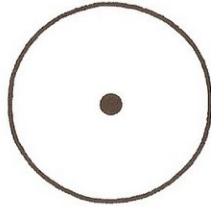
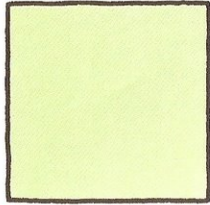



OBJETOS ESCONDIDOS

Busca un gorro, un chaleco, unos guantes y una bufanda. Enciérralos en un círculo.

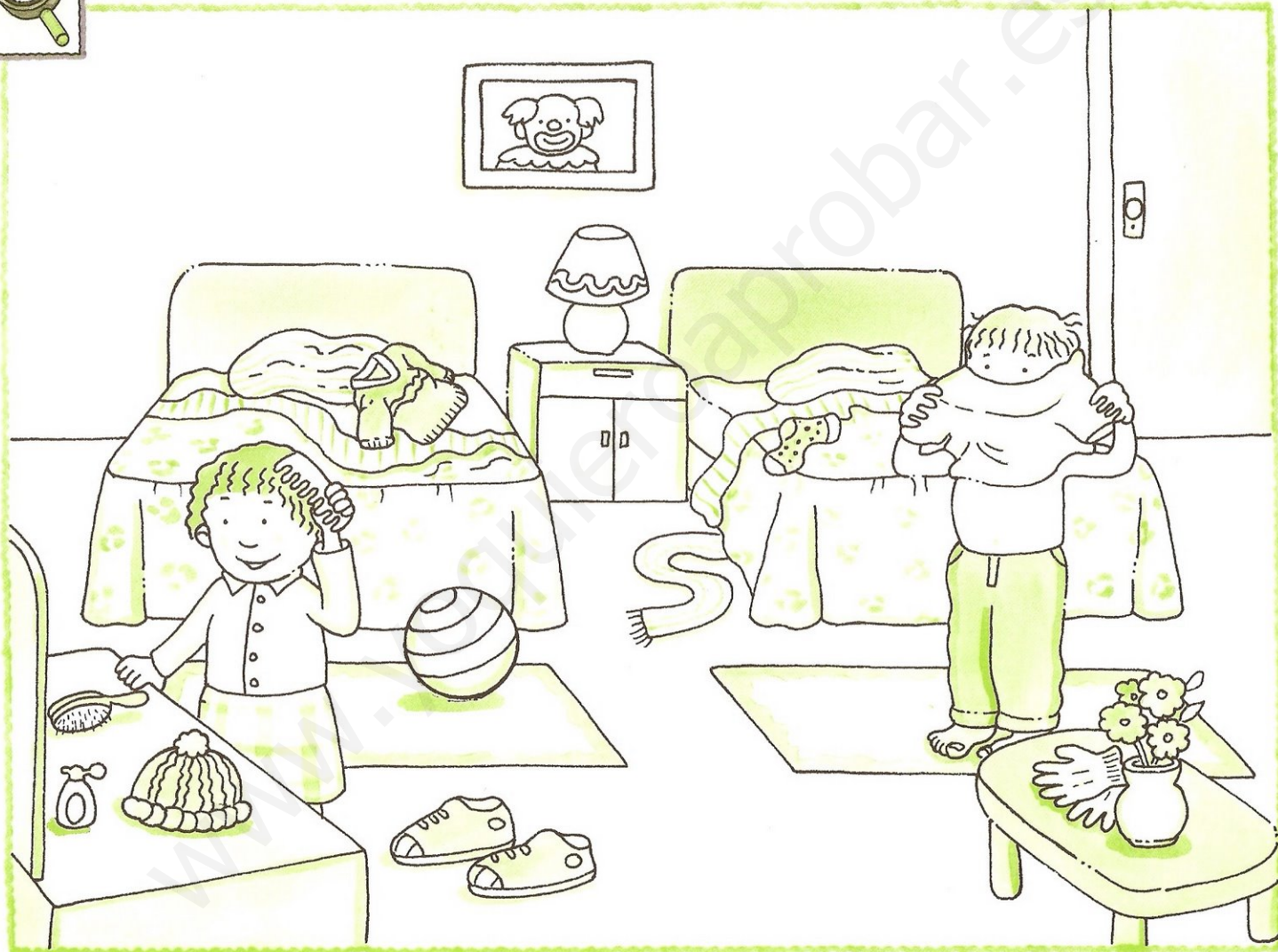



RECONOCIMIENTO DE PROPIEDADES

Pinta los gorros con forma de **triángulo**.





FIGURA - FONDO

Busca una parte de la cara. Píntala.

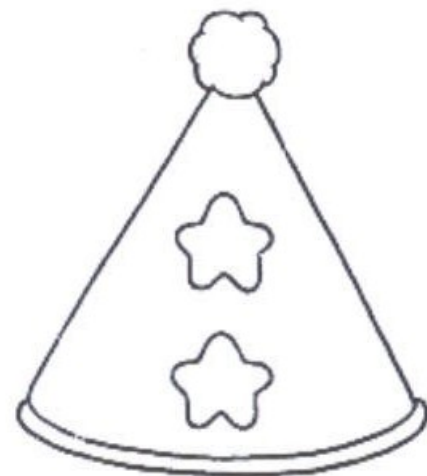
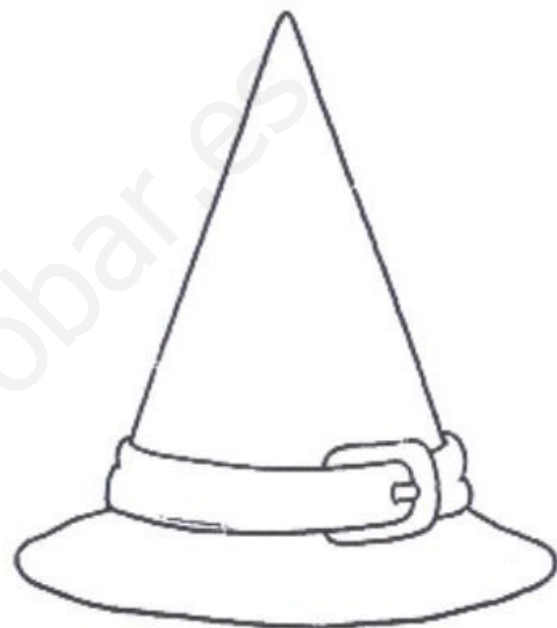
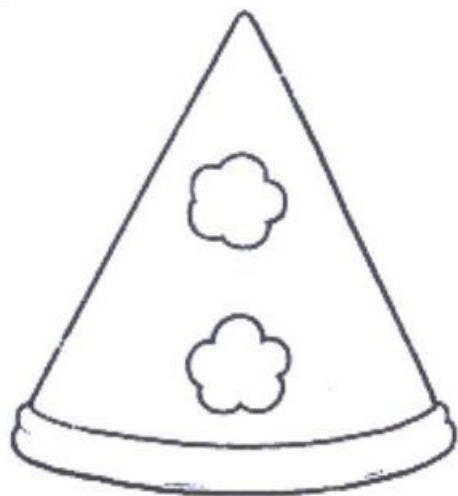
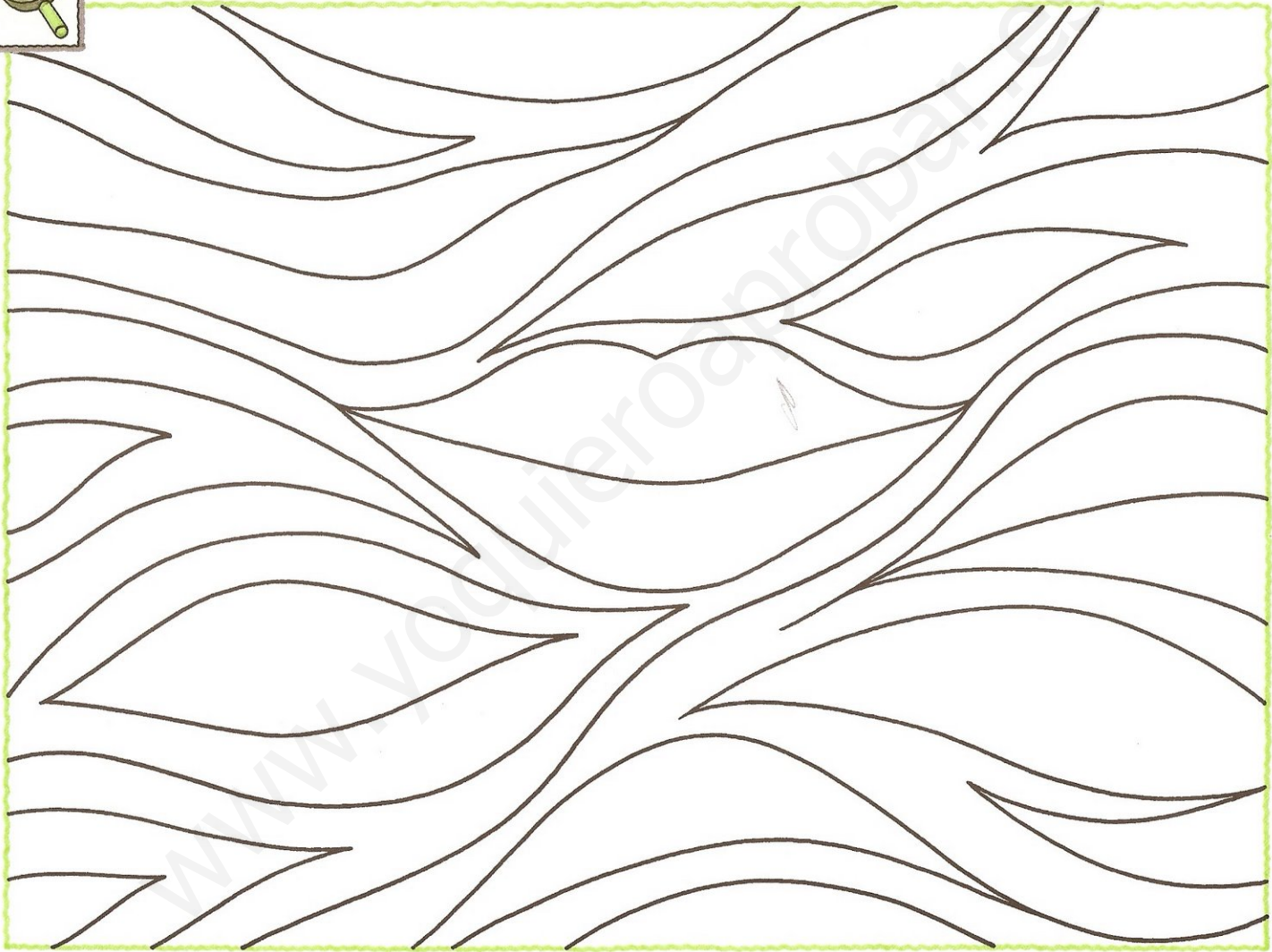

DIBUJOS INCOMPLETOS

Completa la cara del payaso. Píntala.



SEMEJANZAS Y DIFERENCIAS

Pinta la chaqueta **igual** al modelo.





DIBUJOS INCOMPLETOS

Dibuja lo que le falta a cada cara.





RECONOCIMIENTO DE PROPIEDADES

Pinta las figuras **grandes**. Tacha los **triángulos**.

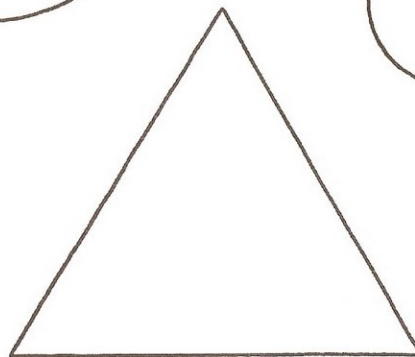
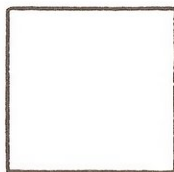
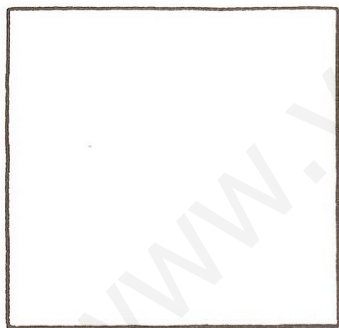
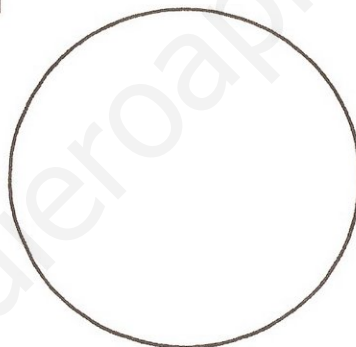
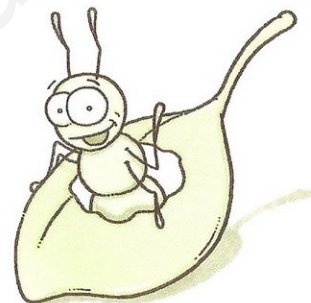
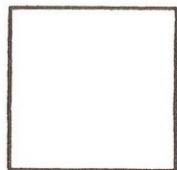

www.yoquieroaprobar.es



FIGURA - FONDO

Pinta el alimento escondido.

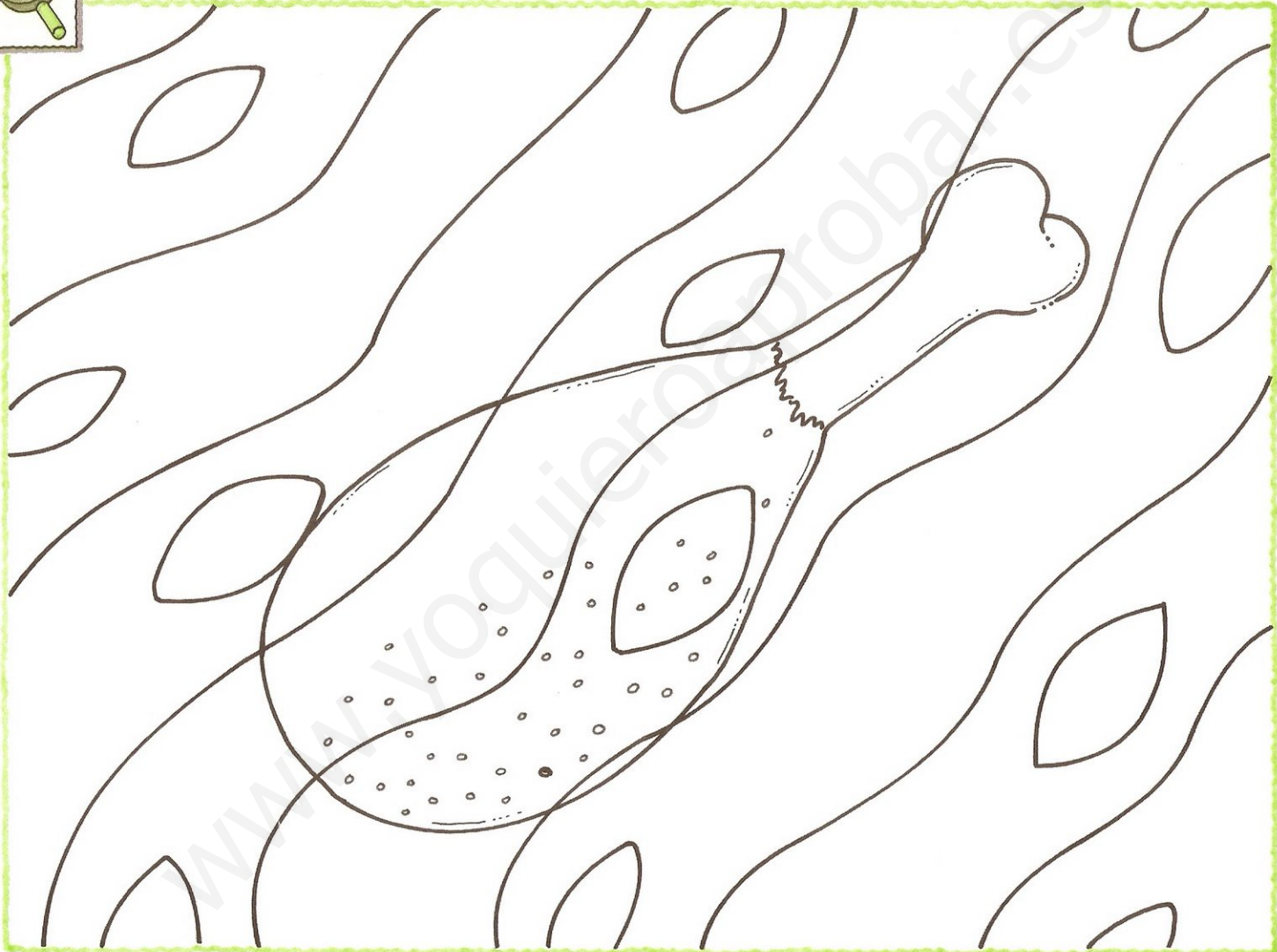



RECONOCIMIENTO DE PROPIEDADES

Pinta la torta más grande.





FIGURA - FONDO

Busca una frutilla. Decórala con pintura digital.

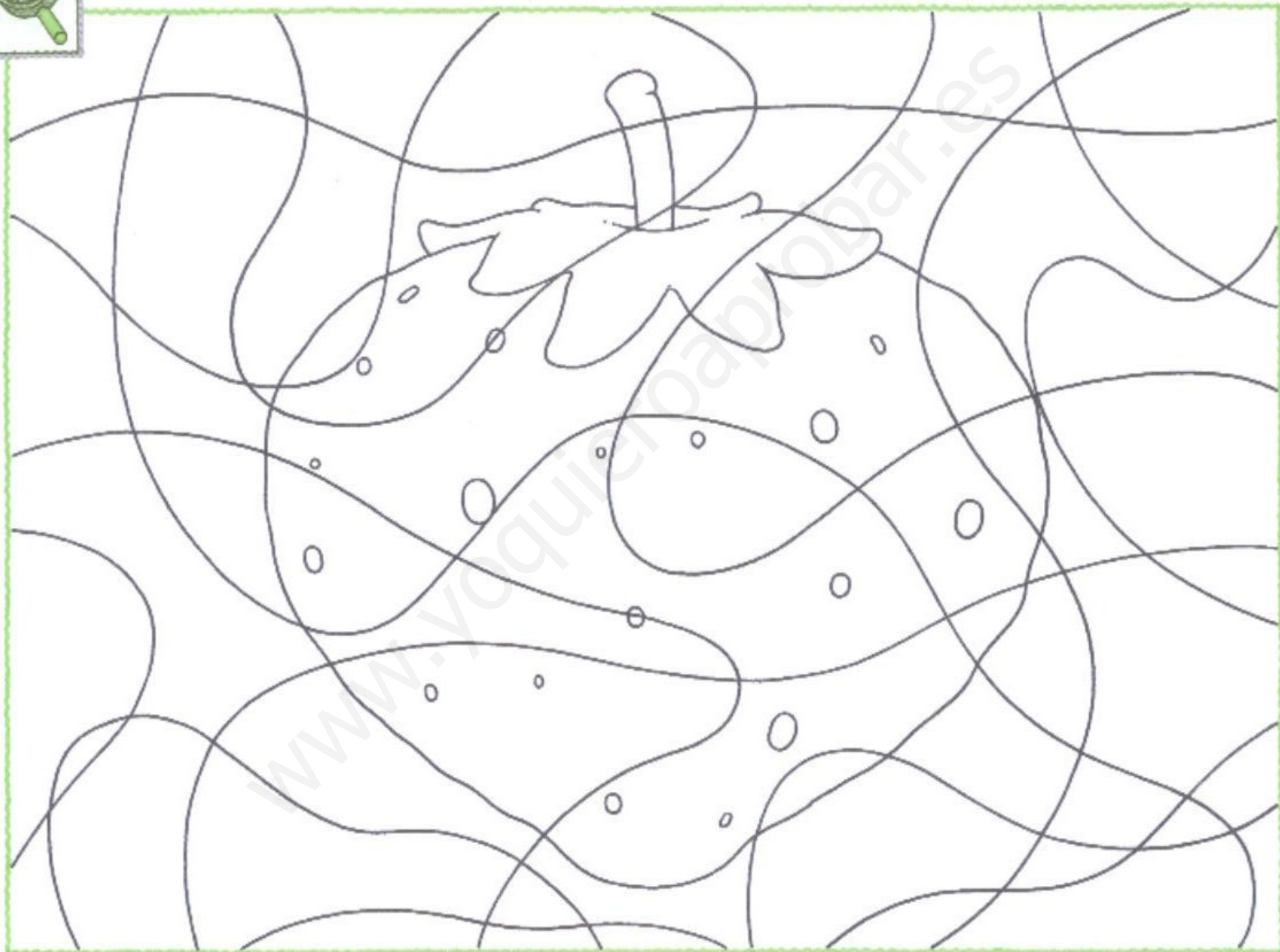



SEMEJANZAS Y DIFERENCIAS

Une con flechas los objetos iguales.

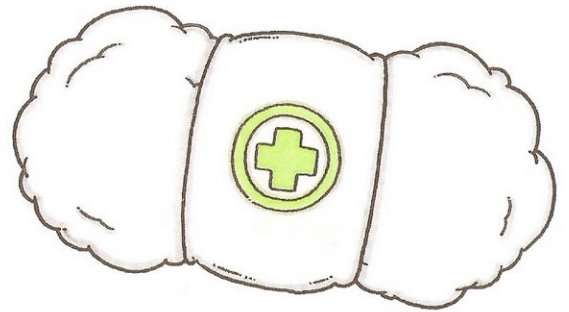
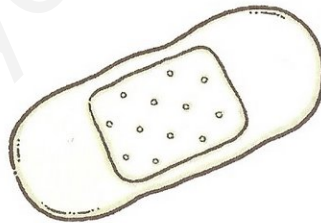
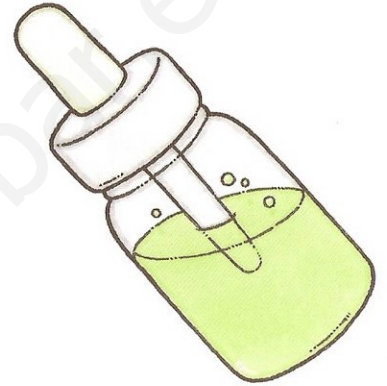
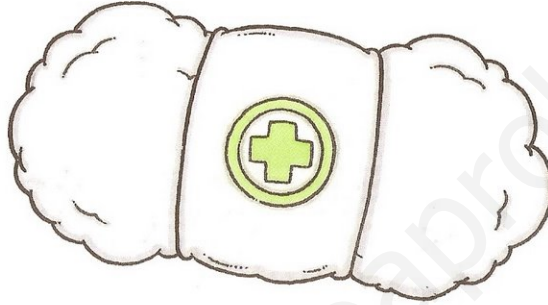
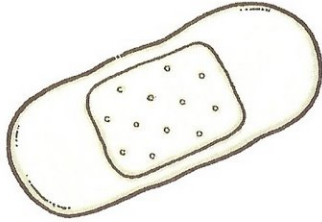

OBJETOS ESCONDIDOS

Busca los plátanos escondidos. Enciérralos en un círculo.

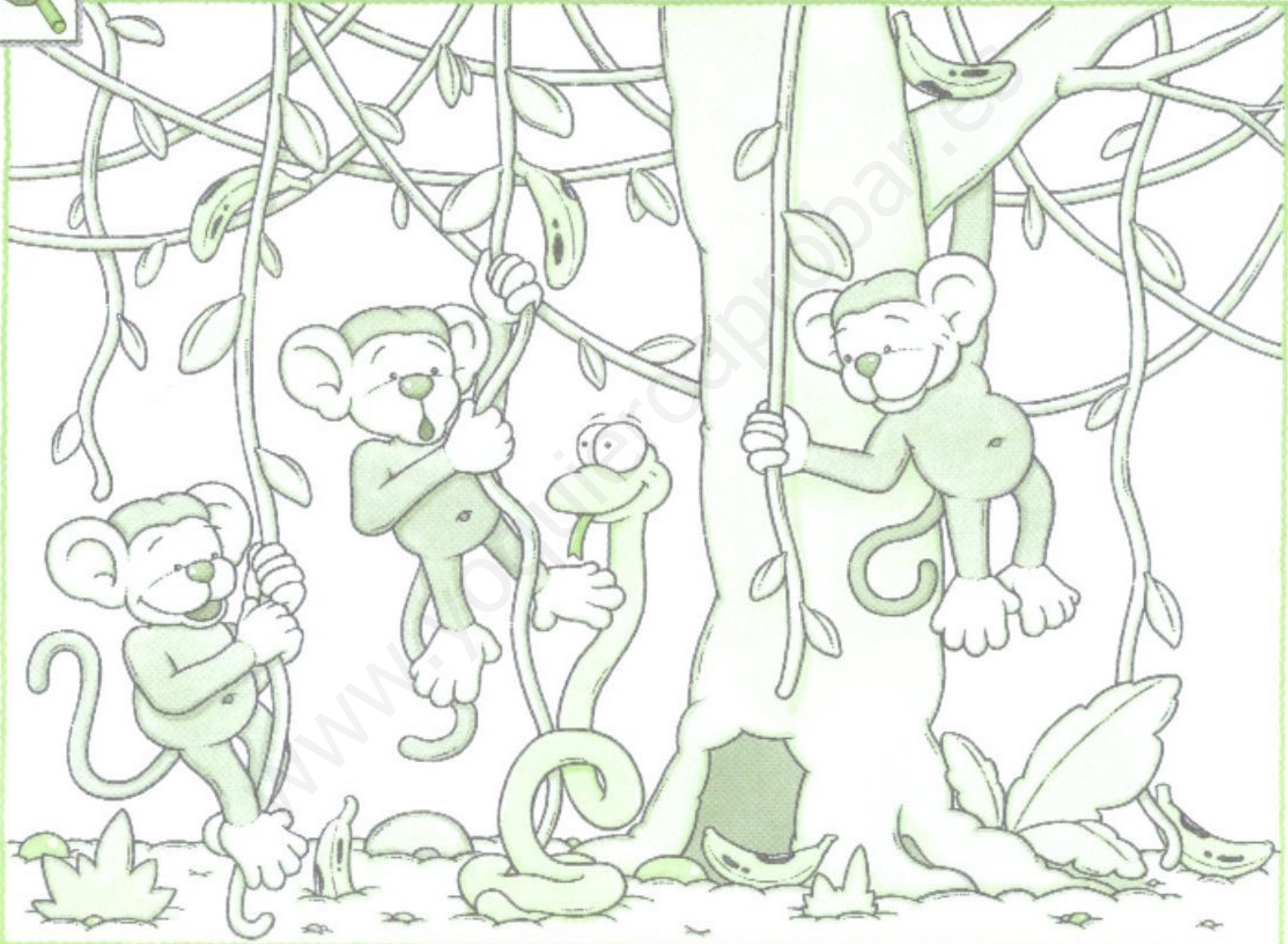



DIBUJOS INCOMPLETOS

Pinta, con pintura digital, la melena que le falta al león.

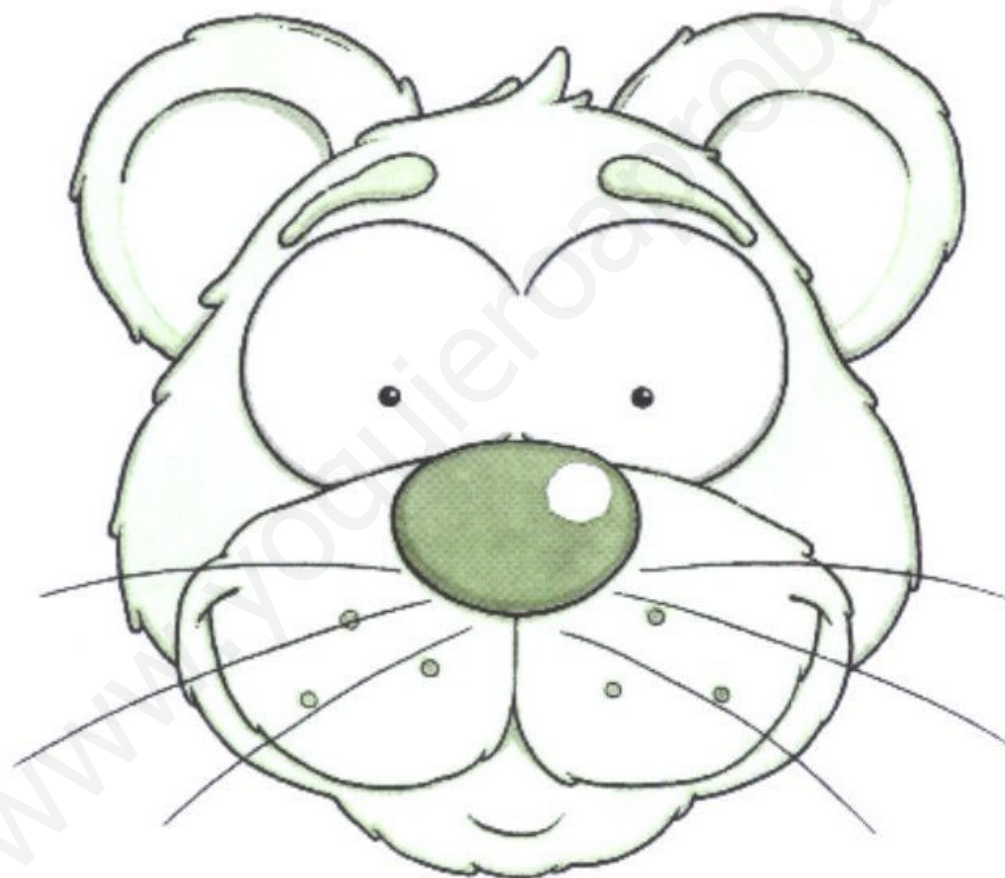

www.youjierodigital.com



FIGURA - FONDO

Pinta el elefante.

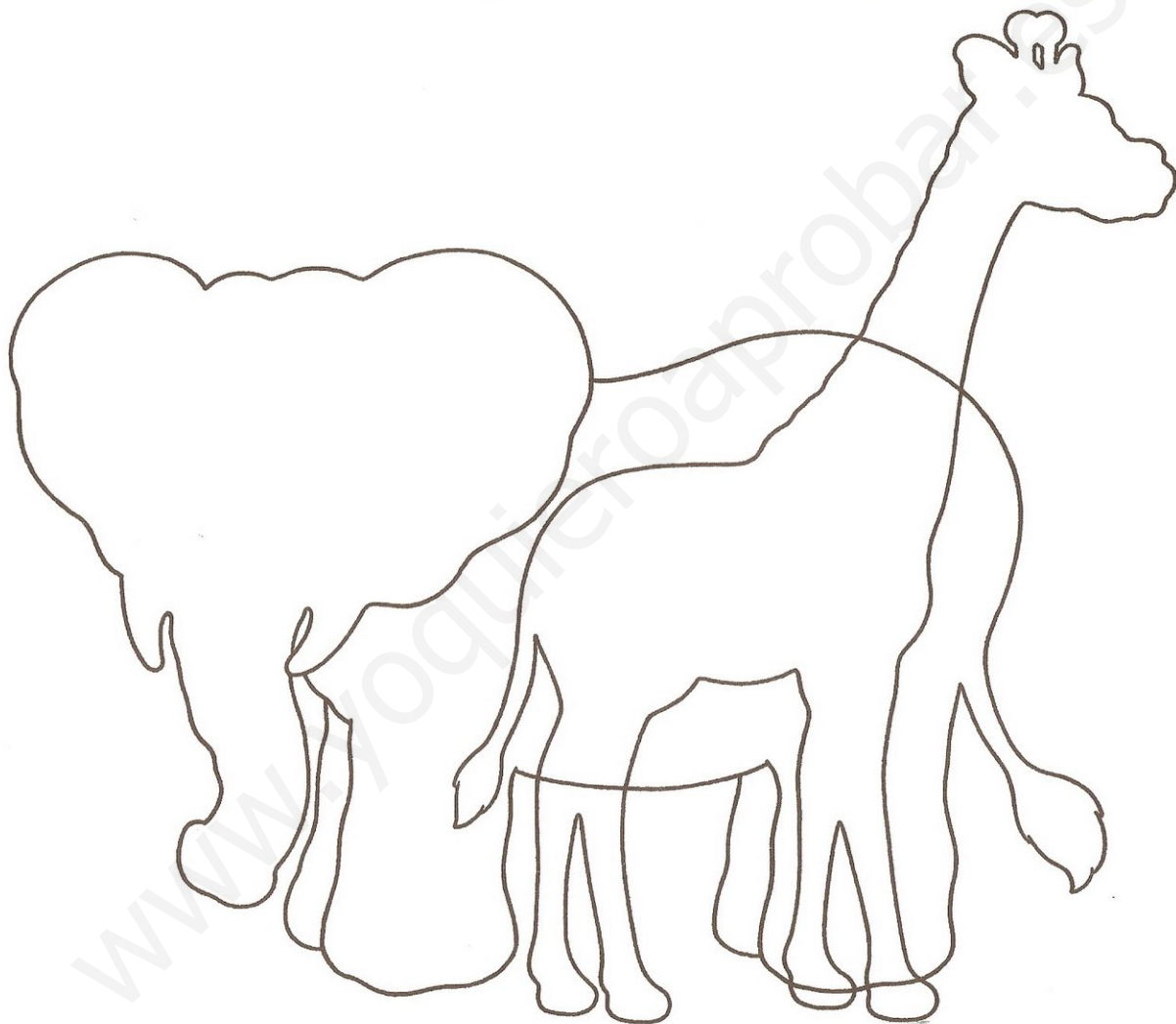



DIBUJOS INCOMPLETOS

Dibuja lo que le falta a cada animal.

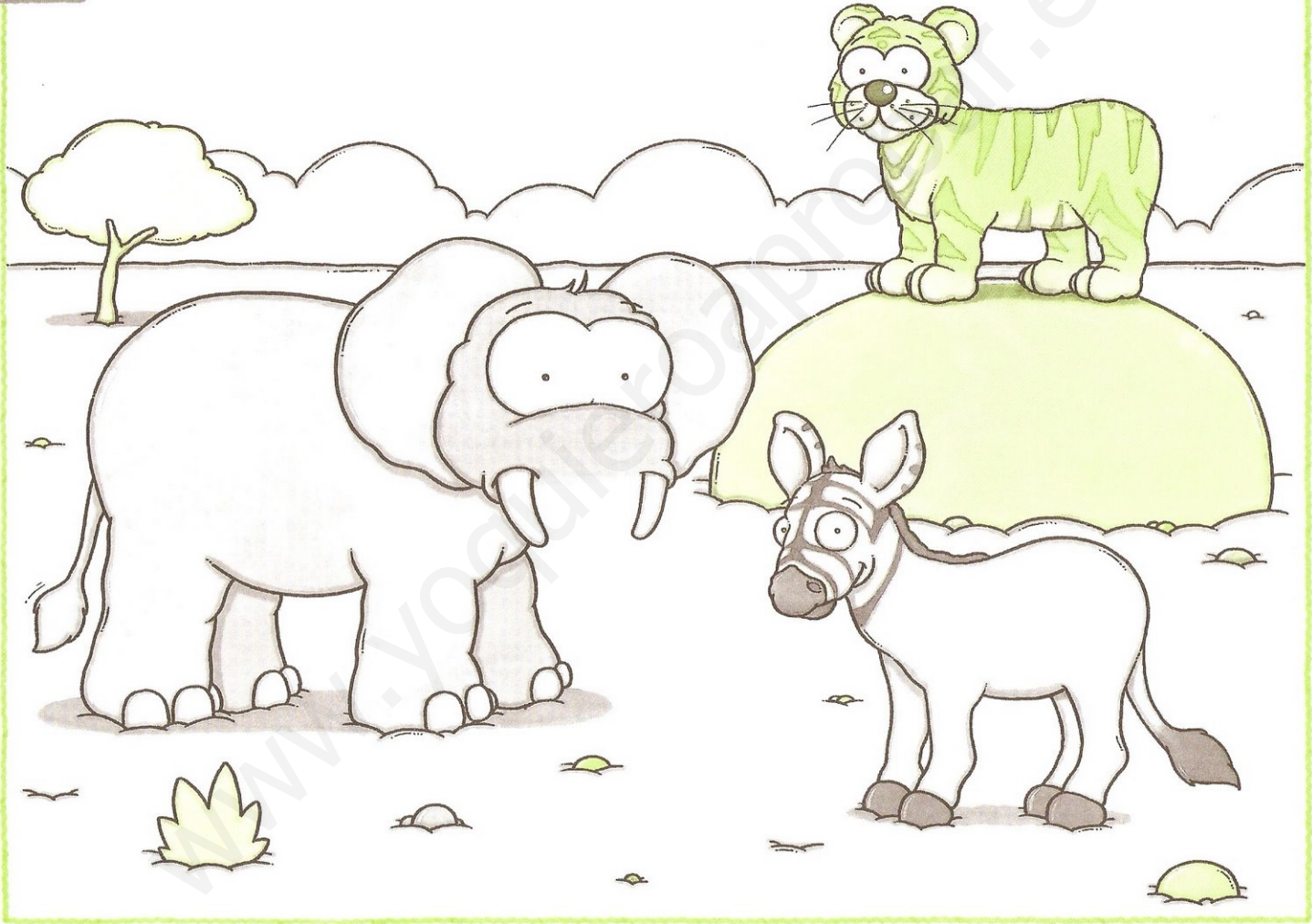



SEMEJANZAS Y DIFERENCIAS

Une con flechas los animales iguales.

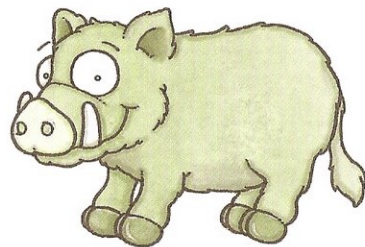
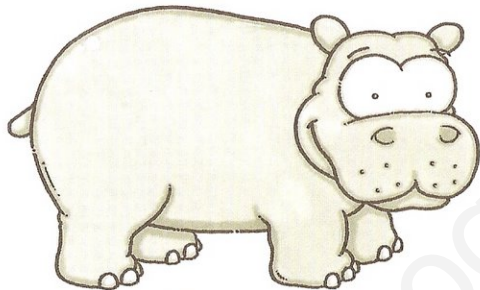
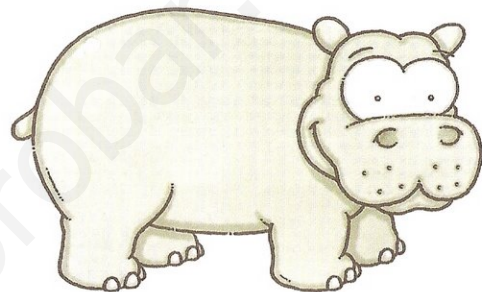



OBJETOS ESCONDIDOS

Busca en el jardín todas las flores iguales a los modelos. Píntalas.





FIGURA - FONDO

Busca la flor y pntala.

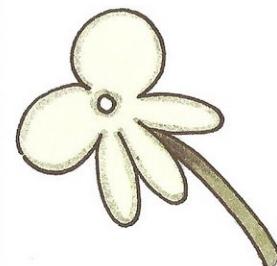
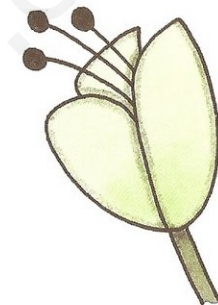
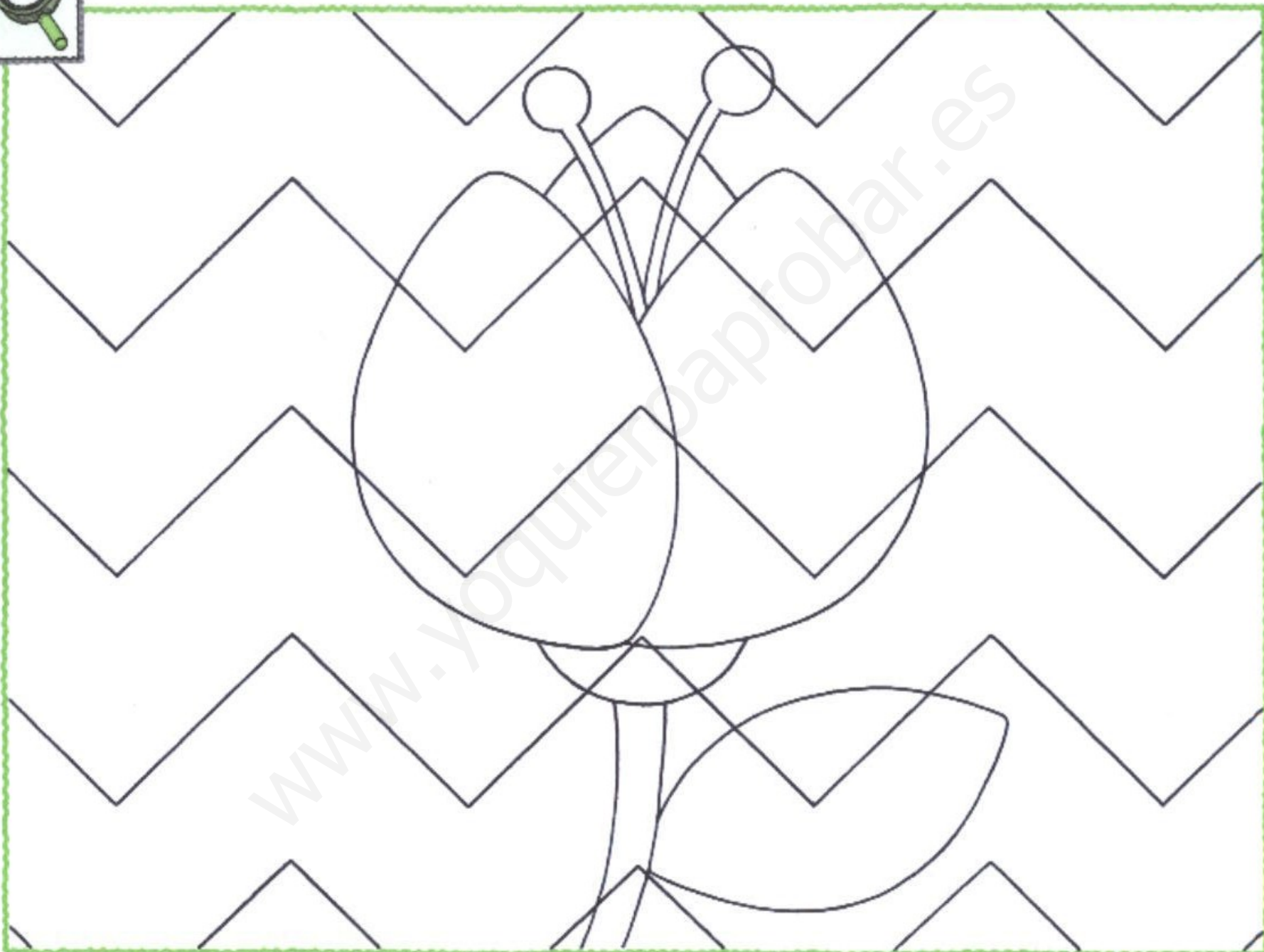

RECONOCIMIENTO DE PROPIEDADES

Pinta el árbol más grande.

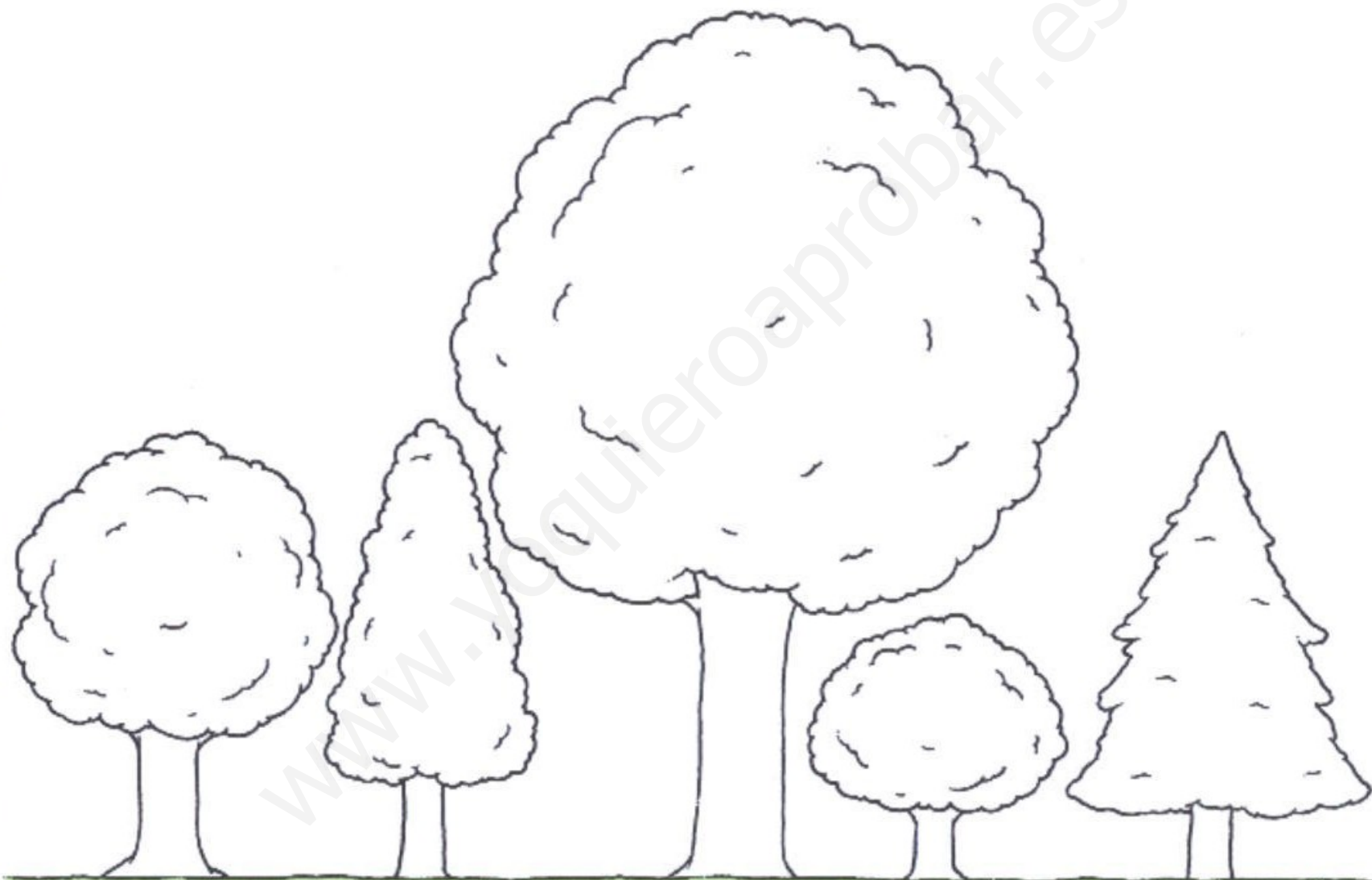



OBJETOS ESCONDIDOS

Pinta los animales del campo.

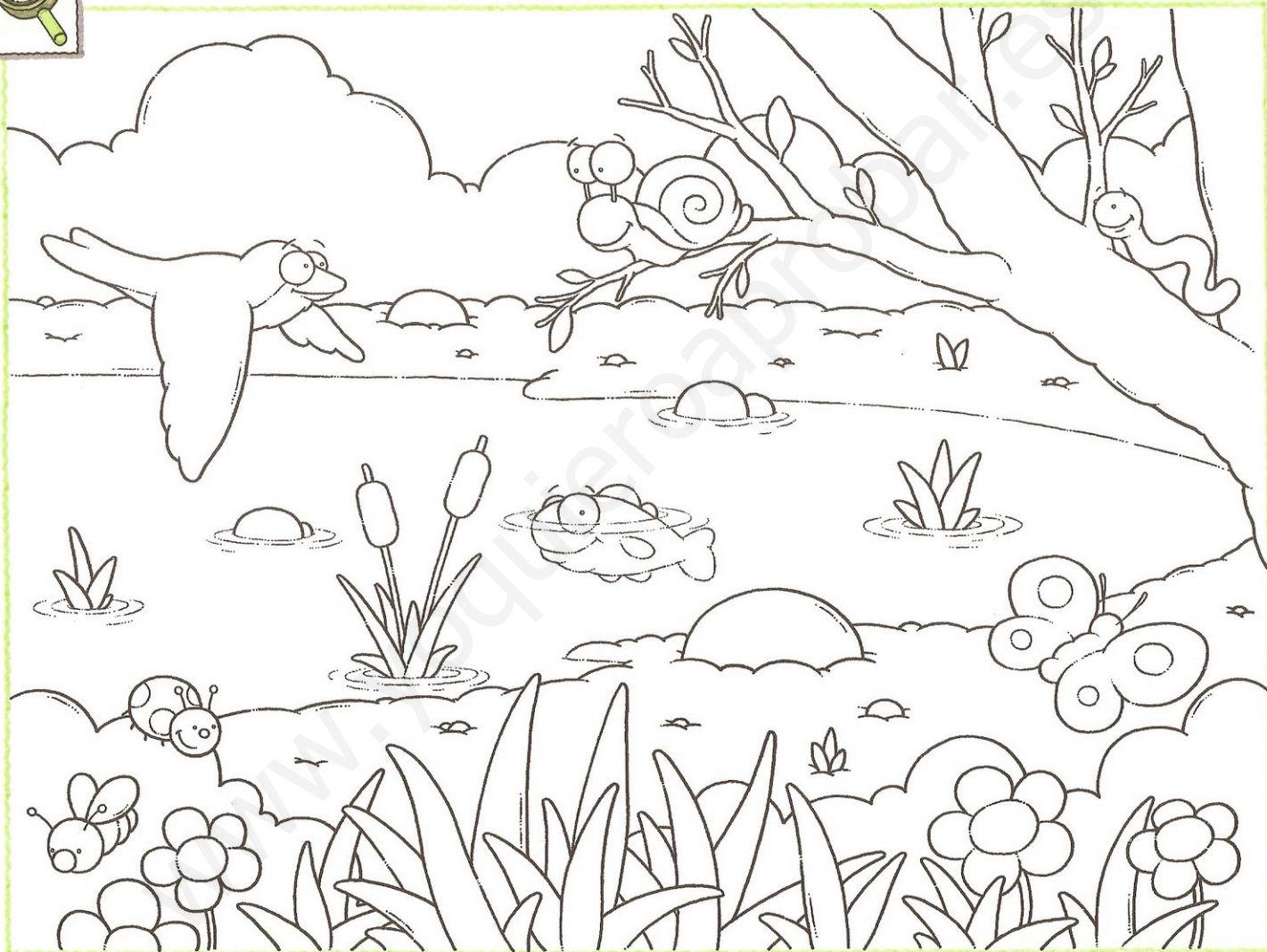



SEMEJANZAS Y DIFERENCIAS

Encierra los dibujos **iguales** al modelo. Tacha los **diferentes**.

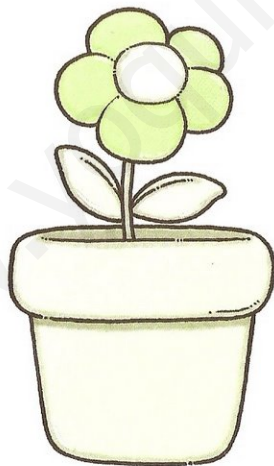
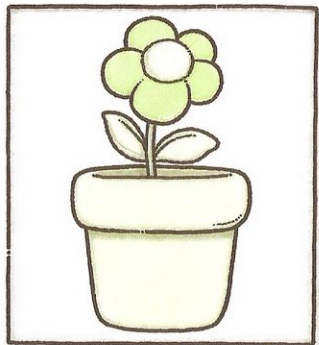



DIBUJOS INCOMPLETOS

Une con flechas lo que le falta a cada animal.

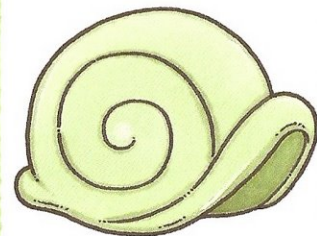
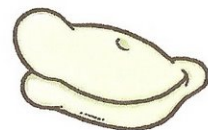
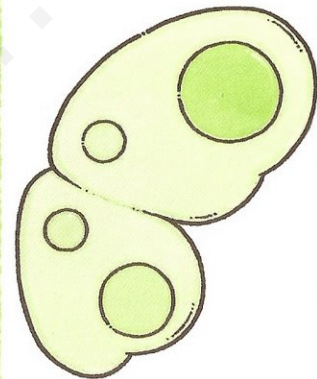
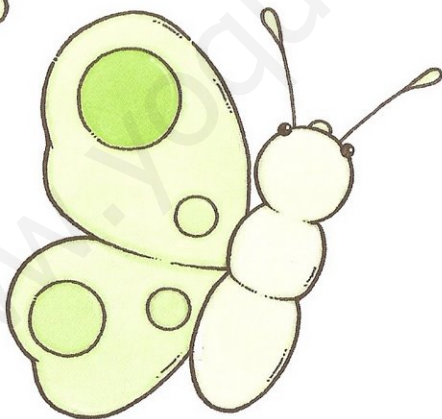
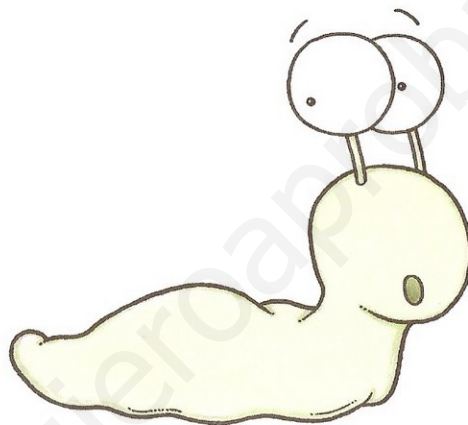
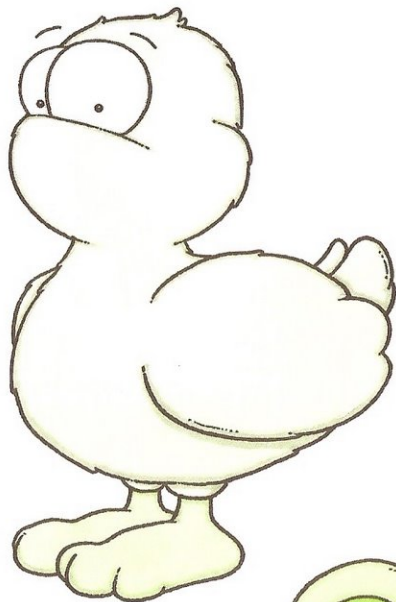



RECONOCIMIENTO DE PROPIEDADES

Pinta de amarillo el animal más **grande**.

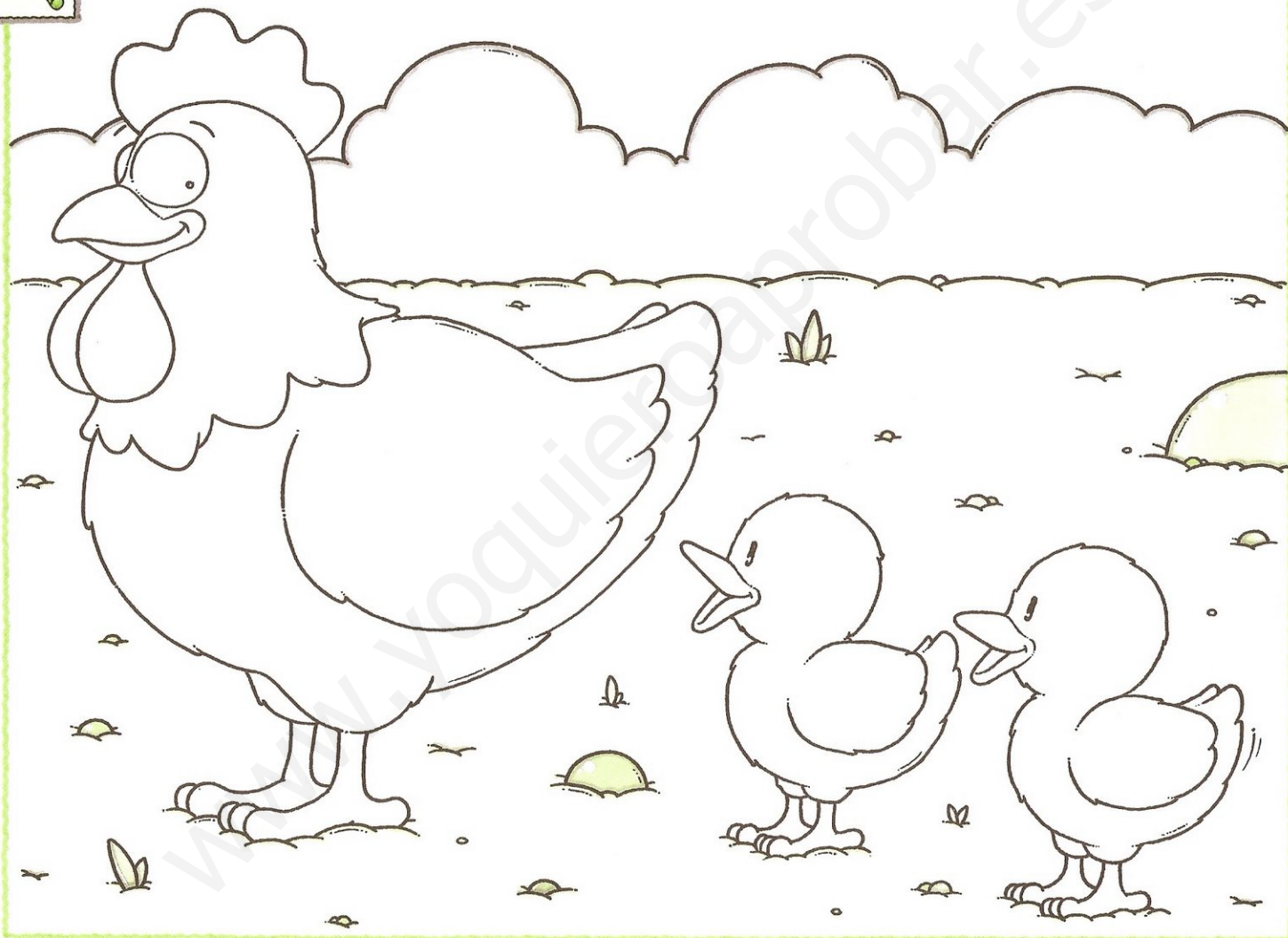

**FIGURA - FONDO**

Busca un animal y pntalo.





OBJETOS ESCONDIDOS

Encierra los objetos que son como los tres modelos.

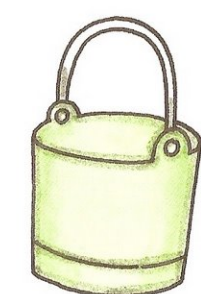
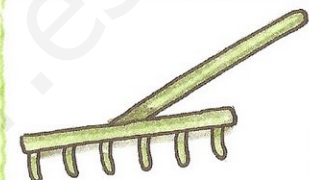

DIBUJOS INCOMPLETOS

Dibuja lo que le falta a cada animal.

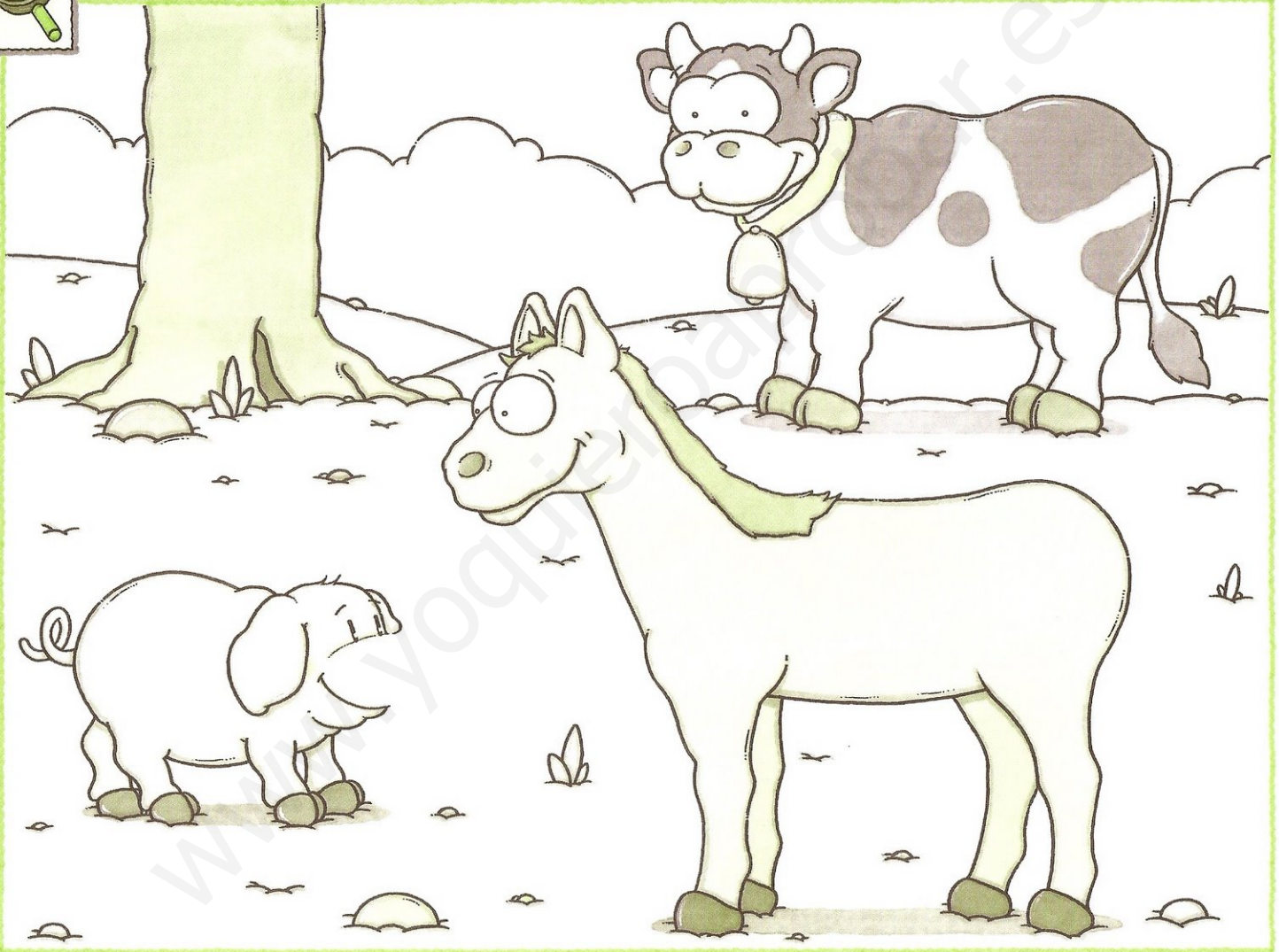

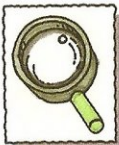

SEMEJANZAS Y DIFERENCIAS

Pinta la figura **diferente** al modelo.

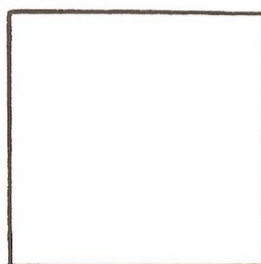
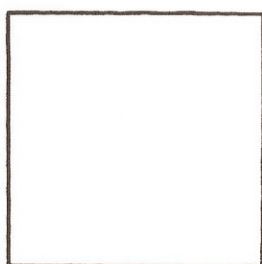
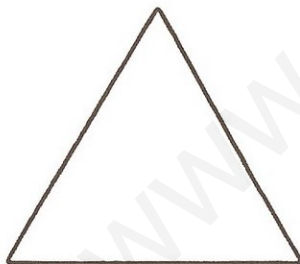
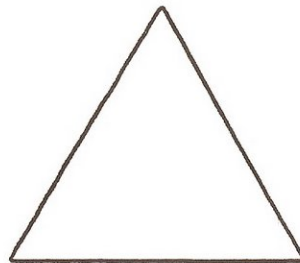
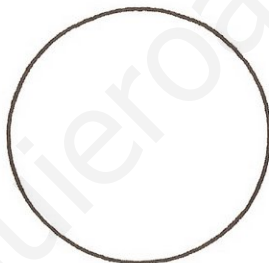
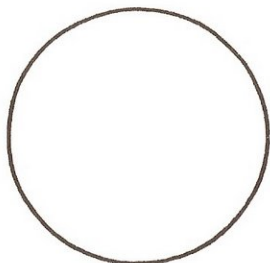
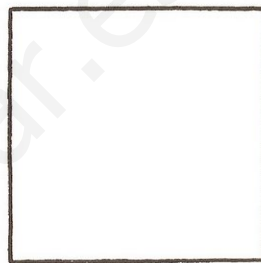
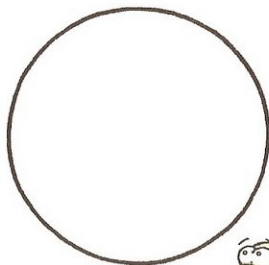
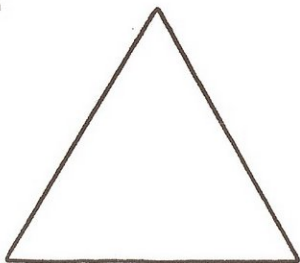

www.yoquieroaprobar.es



FIGURA - FONDO

Repasa de un color diferente cada uno de los dibujos.

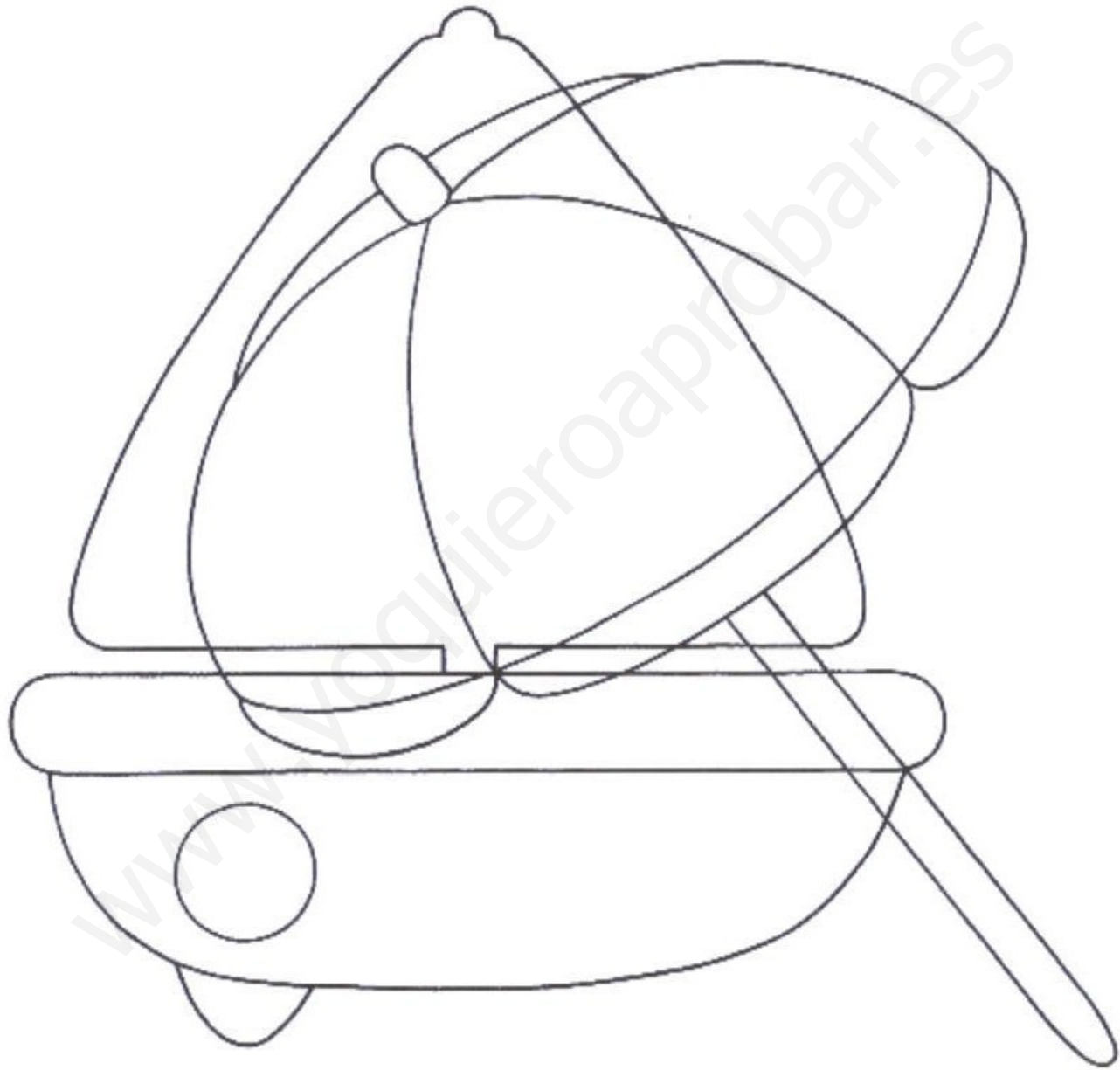



SEMEJANZAS Y DIFERENCIAS

Une con flechas las prendas **iguales**. Píntalas.



SEMEJANZAS Y DIFERENCIAS

Pinta el dibujo igual al modelo.

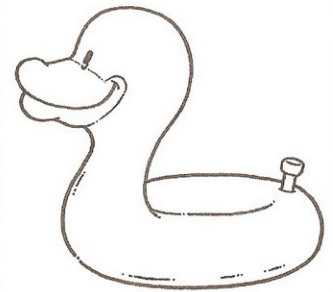
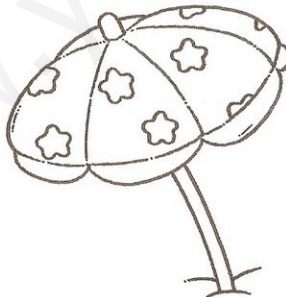
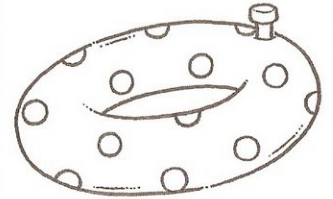
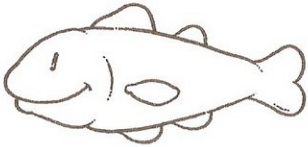
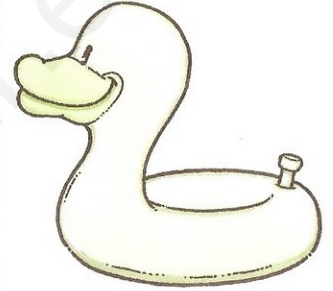
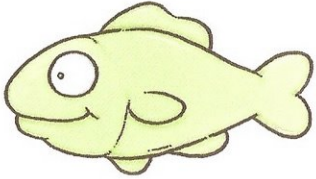

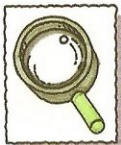

OBJETOS ESCONDIDOS

Encierra los objetos que son como los cuatro modelos.

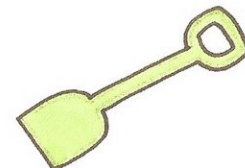
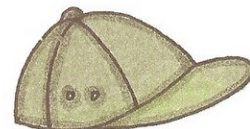

SEMEJANZAS Y DIFERENCIAS

Pinta los dibujos **iguales** al modelo.

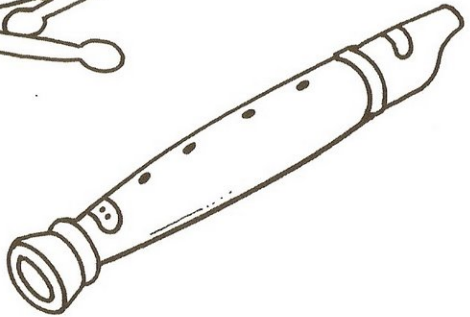
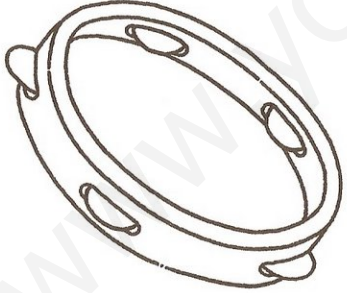
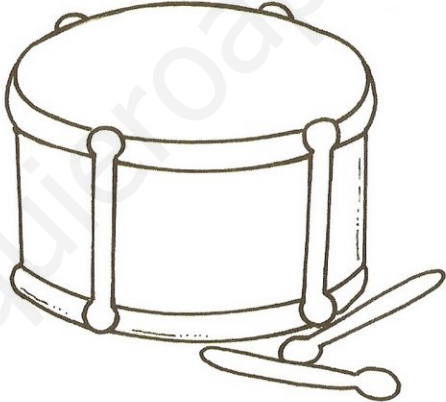
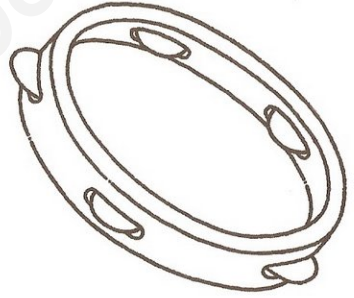
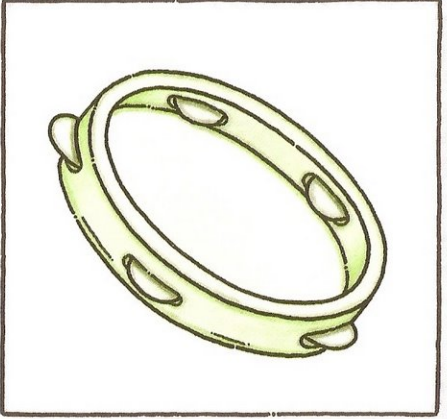

www.wodolier.com/aprobar.es

OBJETOS ESCONDIDOS

Pinta el dibujo. Encierra lo que le falta al Rey Mago.





FIGURA - FONDO

Busca la oveja del pesebre y pntala.



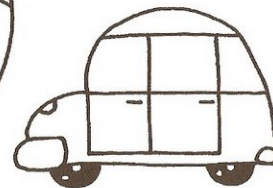
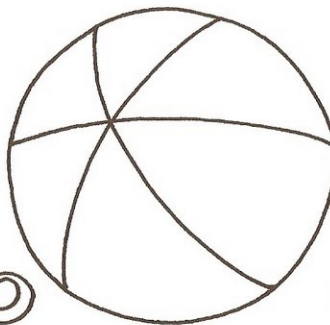
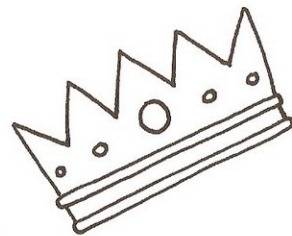
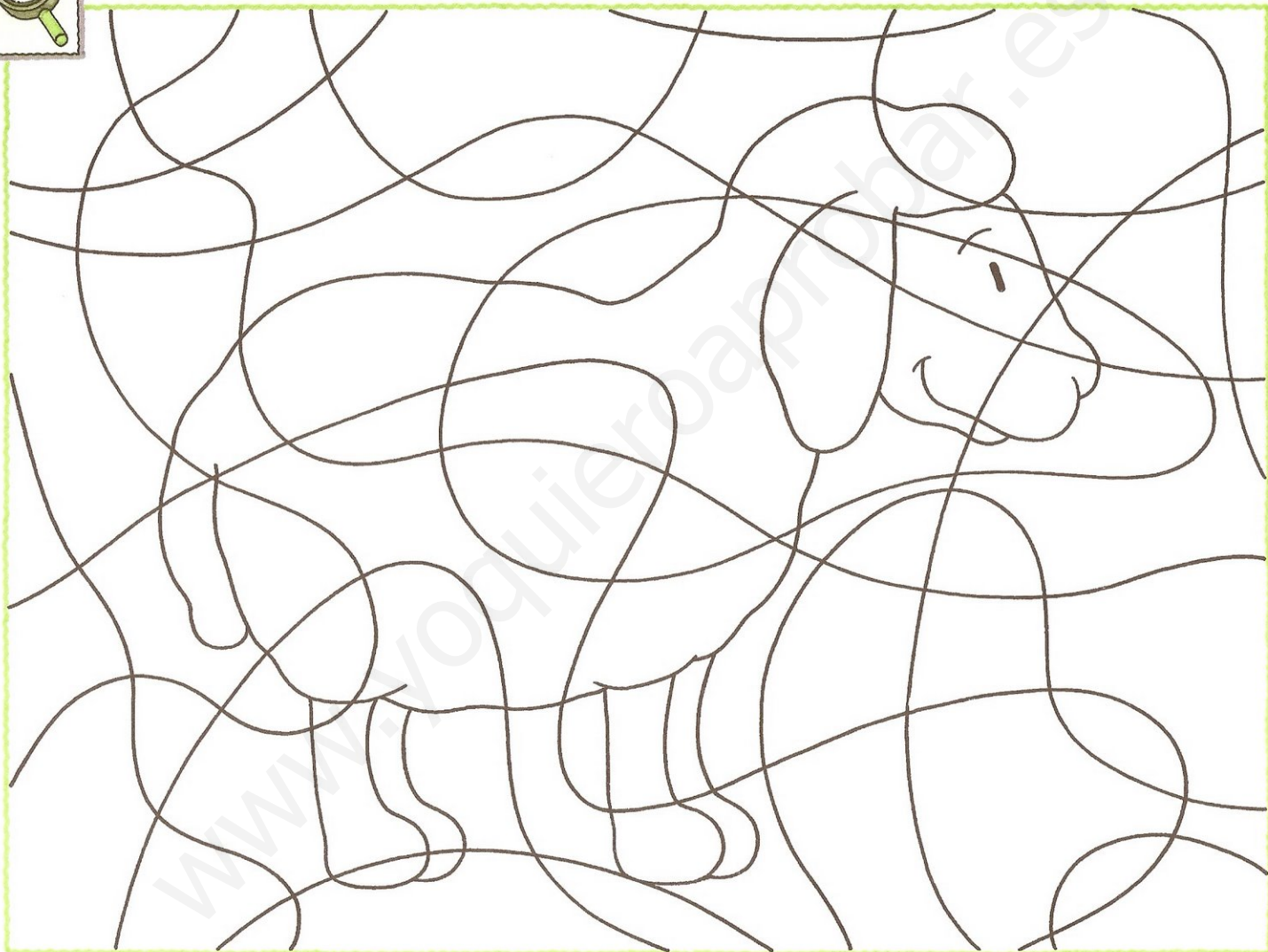

RECONOCIMIENTO DE PROPIEDADES

Pega papel lustre de color amarillo en la estrella **grande**.

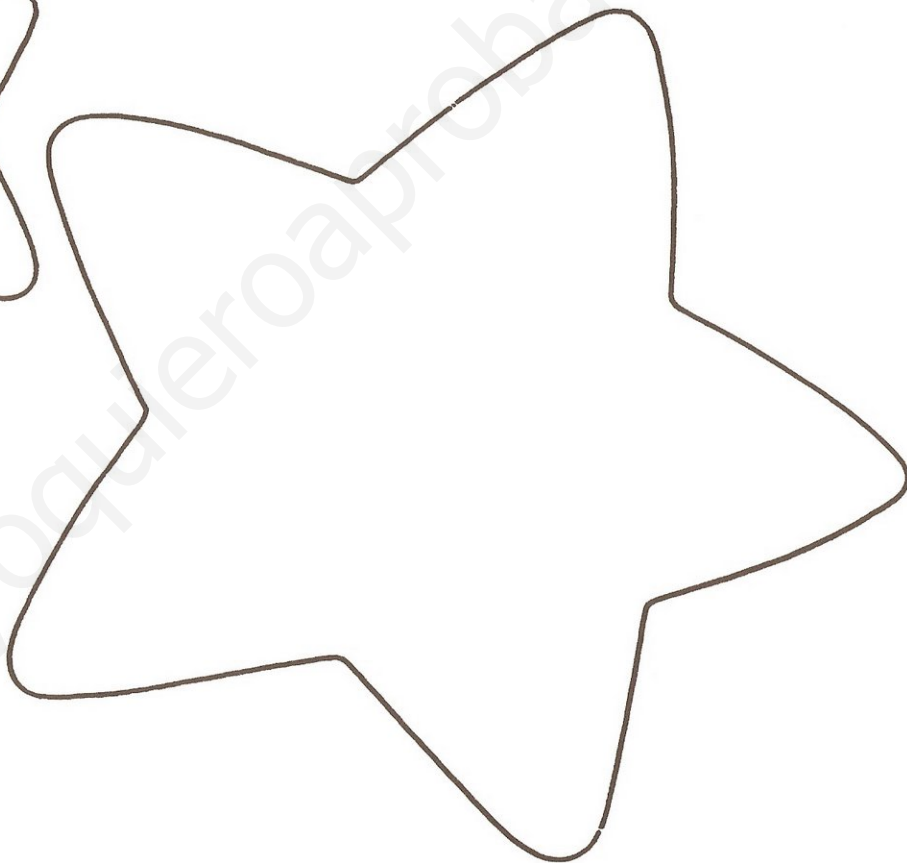
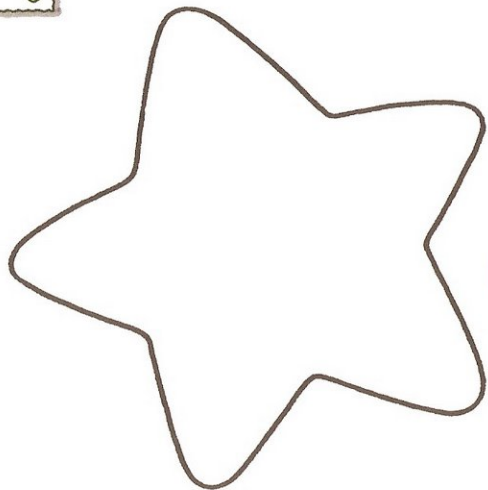

www.yoquieroaprobar.es



DIBUJOS INCOMPLETOS

Repasa la línea punteada para completar la campana. Píntala.

