

EDUCACIÓN INFANTIL

5º CURSO

Grafomotricidad 1

www.yoquieroaprender.es

TRAZA

líneas verticales siguiendo el modelo.

Grafomotricidad inicial

1

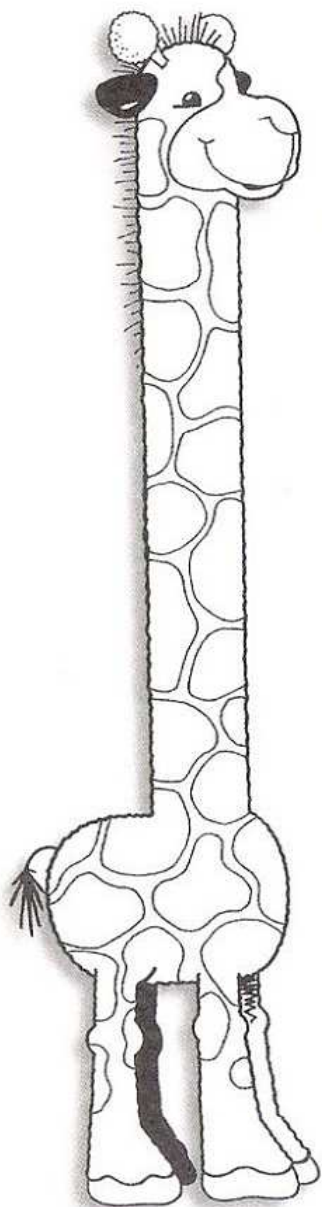

www.yoquieroaprobar.es

TRAZA líneas horizontales siguiendo el modelo.

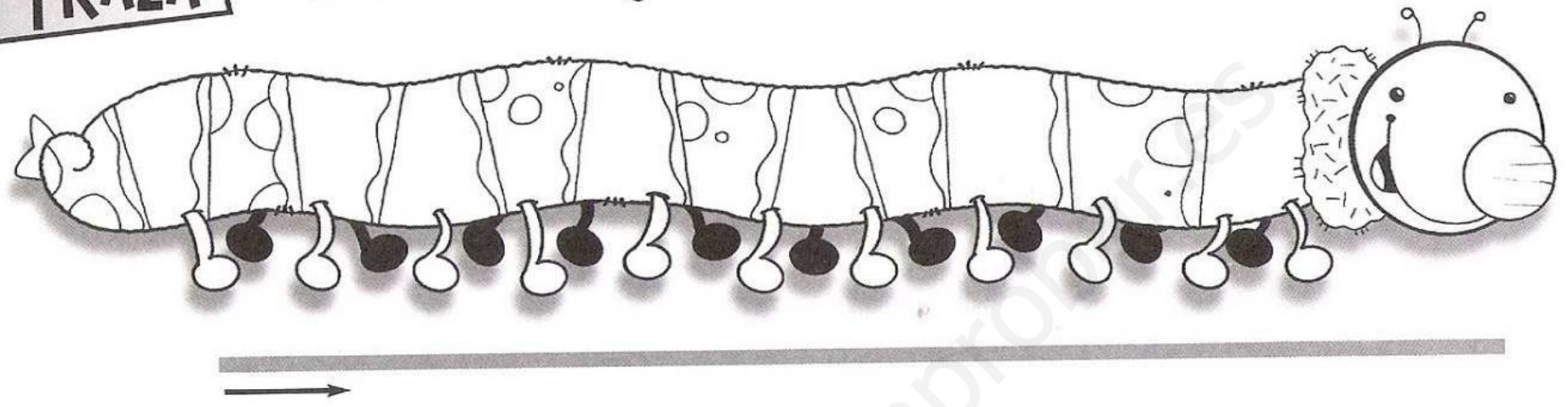

www.yoquieroaprender.es

DIBUJA

los rayos del Sol.

Grafomotricidad inicial
3

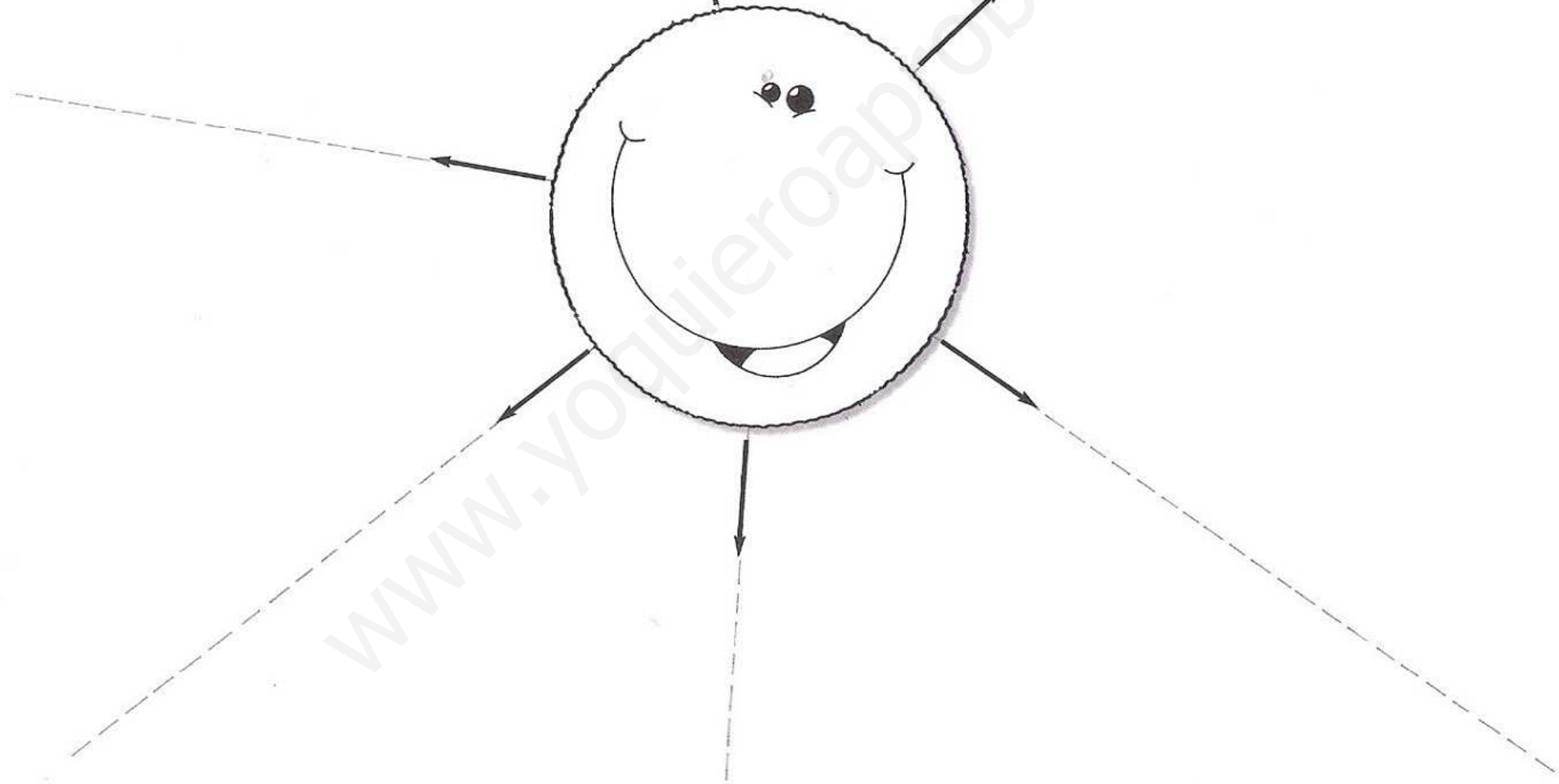

www.yoquieroaprender.es

DIBUJA

las olas y el Sol.

Grafomotricidad inicial
4

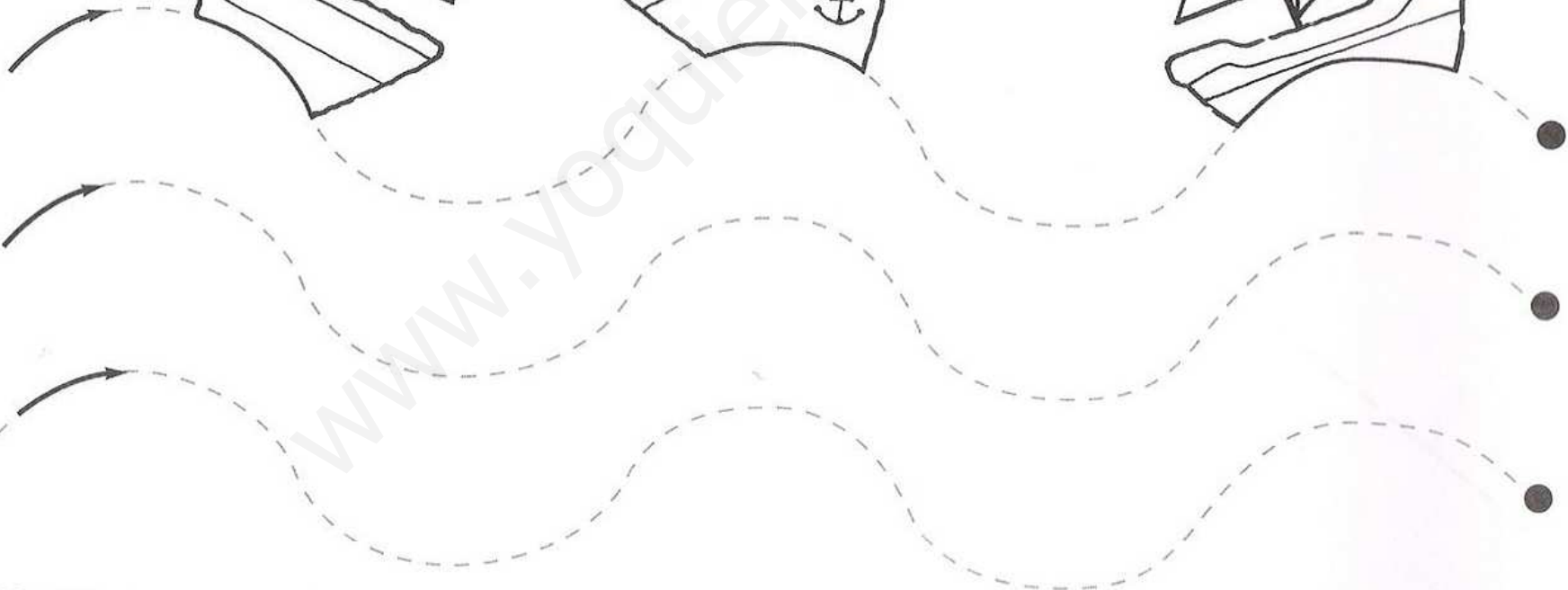
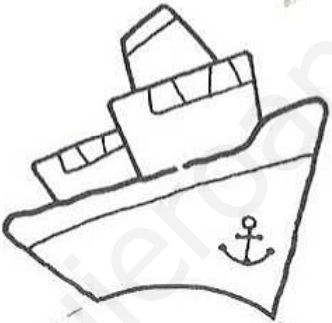
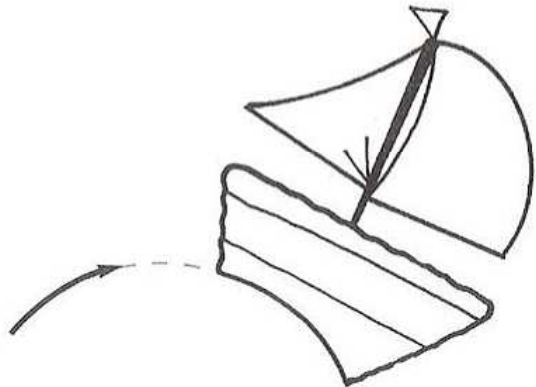
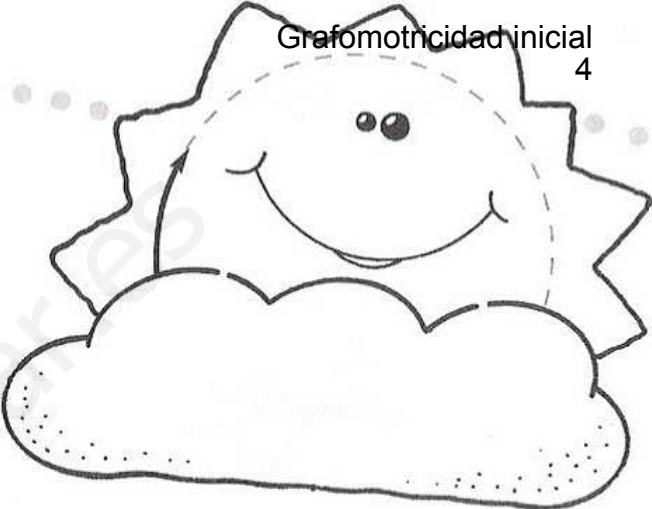

TRAZA

las líneas de la cola del pavo real.

Grafomotricidad inicial
5

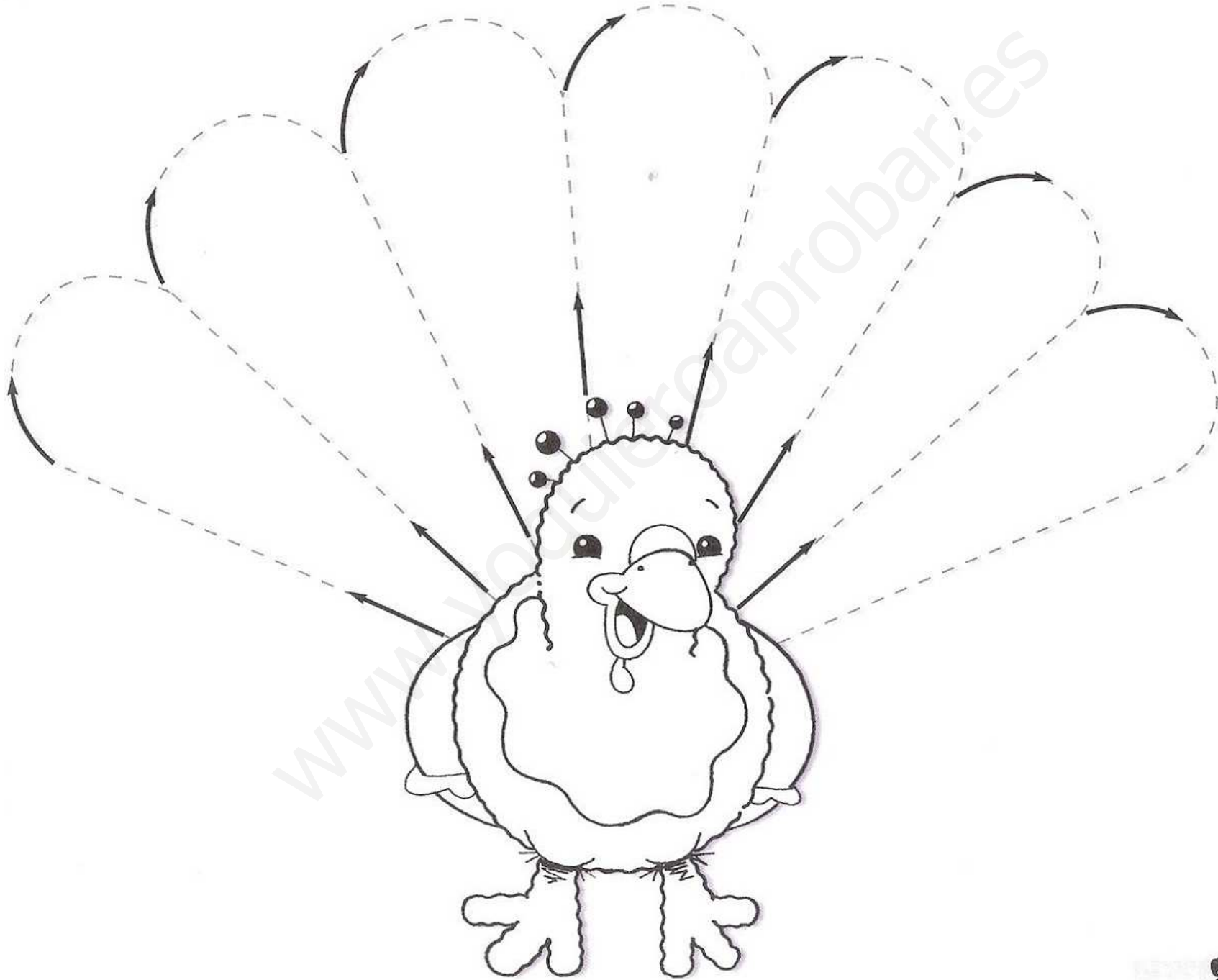

MARCA el camino de cada animalito hasta llegar al punto.

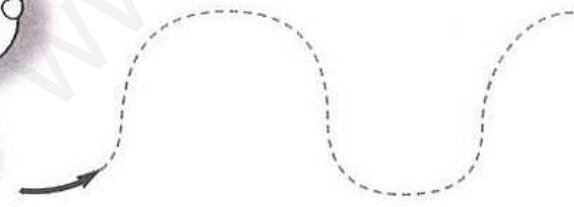
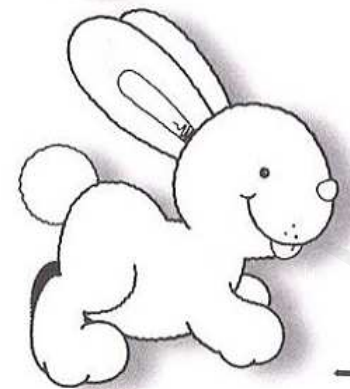
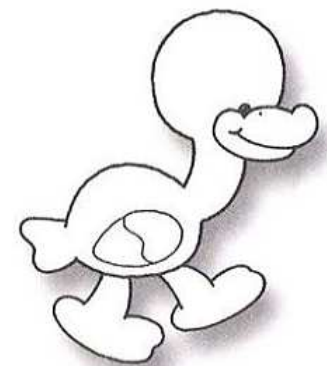
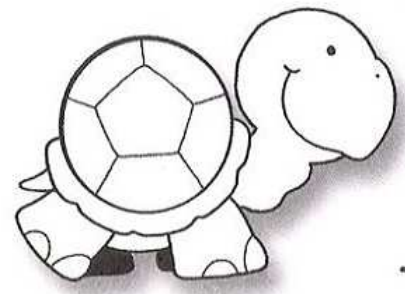

www.yoquieroaprobar.es

TRAZA

el recorrido de cada animalito, siguiendo la flecha hasta llegar al punto.

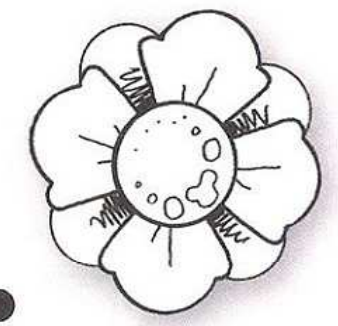
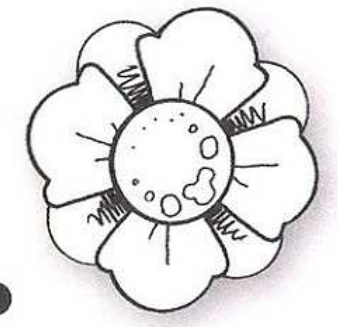
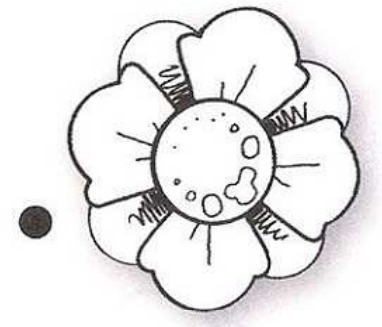
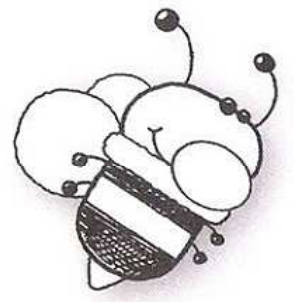
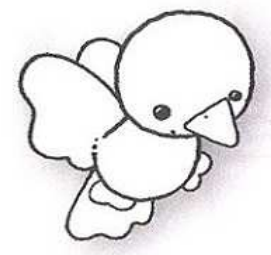
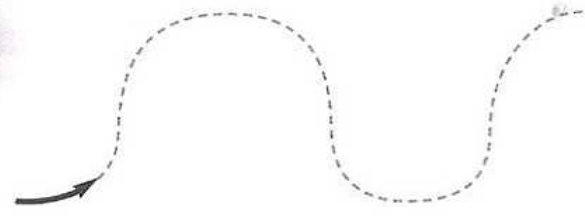
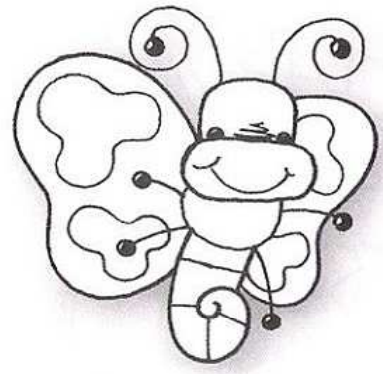

www.yoquieroaprobar.es

MARCA

el recorrido que deberá hacer el ternero para encontrar a su mamá.

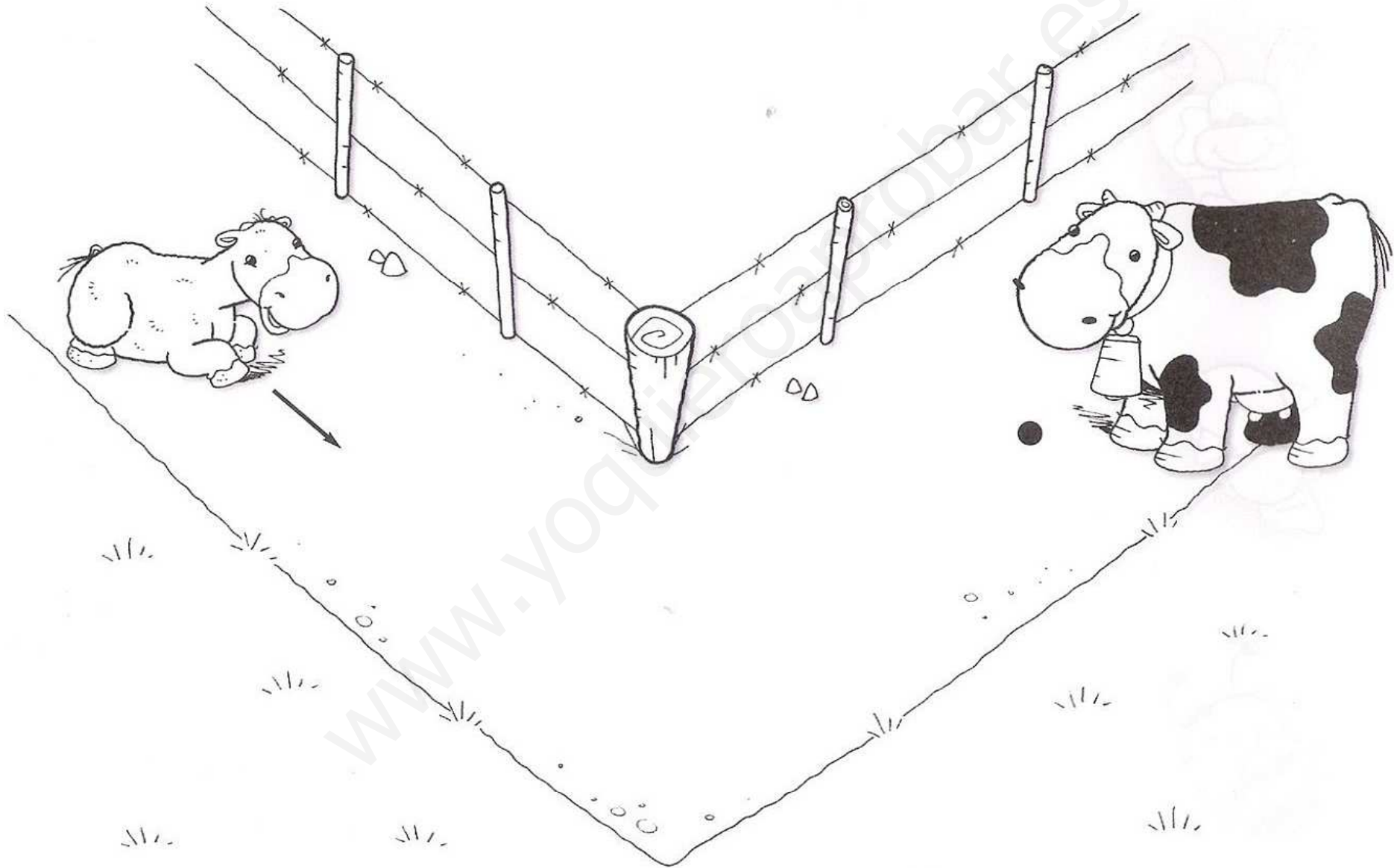

TRAZA

el camino que tendrá que recorrer el coche para llegar a la meta.

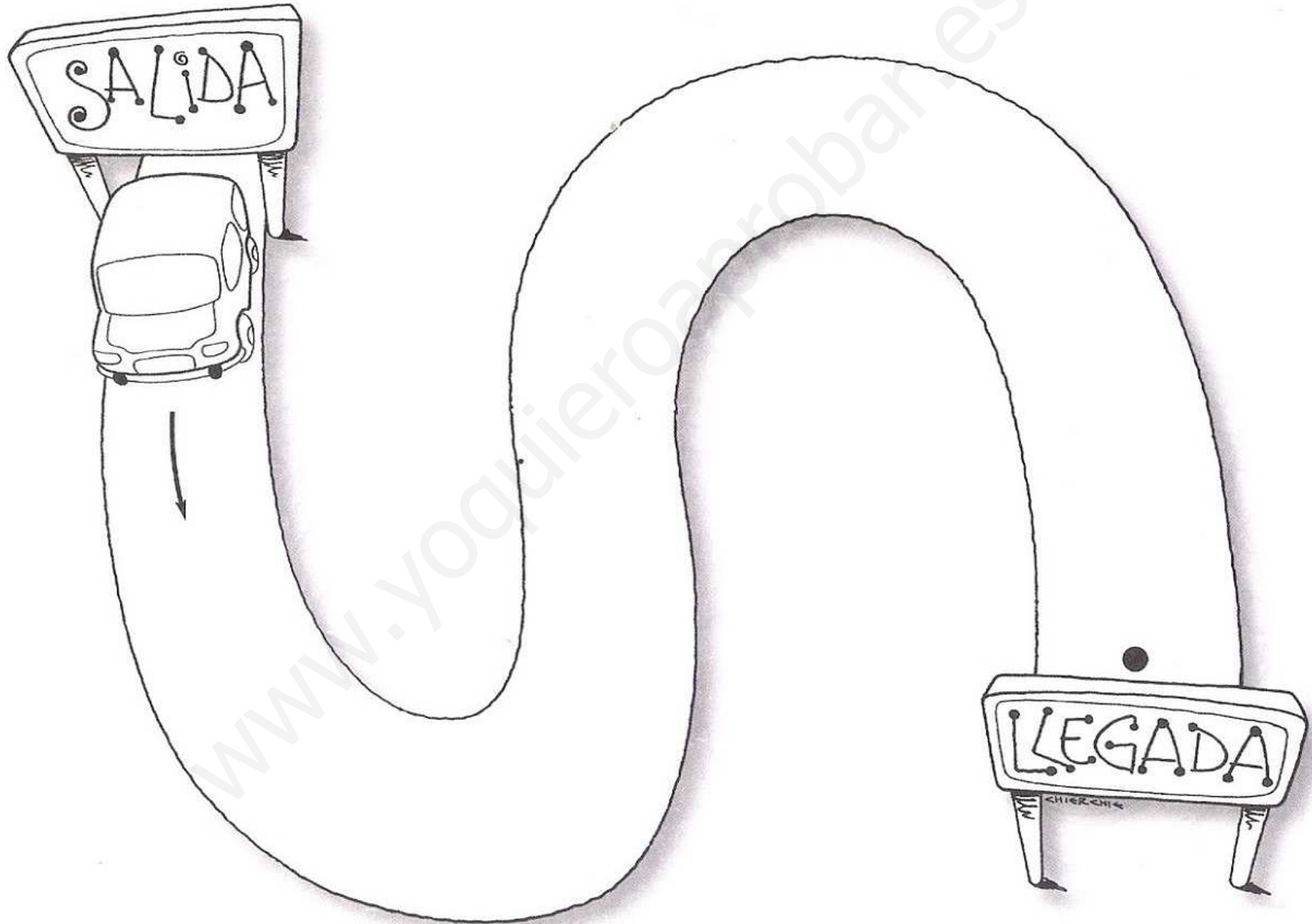

DIBUJA

líneas oblicuas siguiendo el modelo,
en la dirección de la flecha.

Grafomotricidad inicial
10

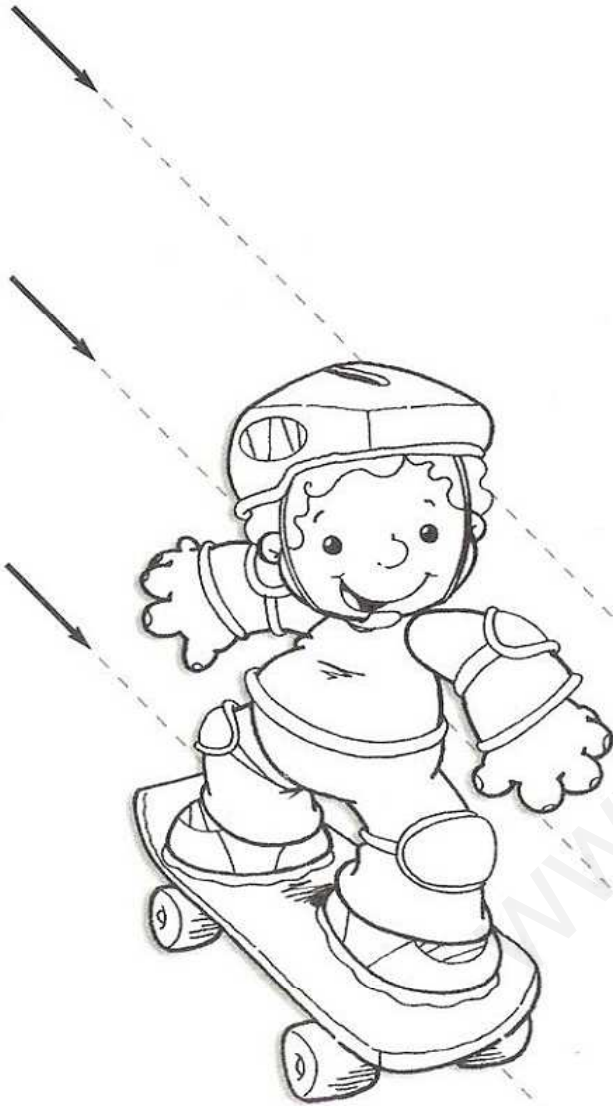

www.yoquieroaprobar.es

MARCA

el arco iris con sus respectivos colores.

Que las flechas te sirvan de guía.

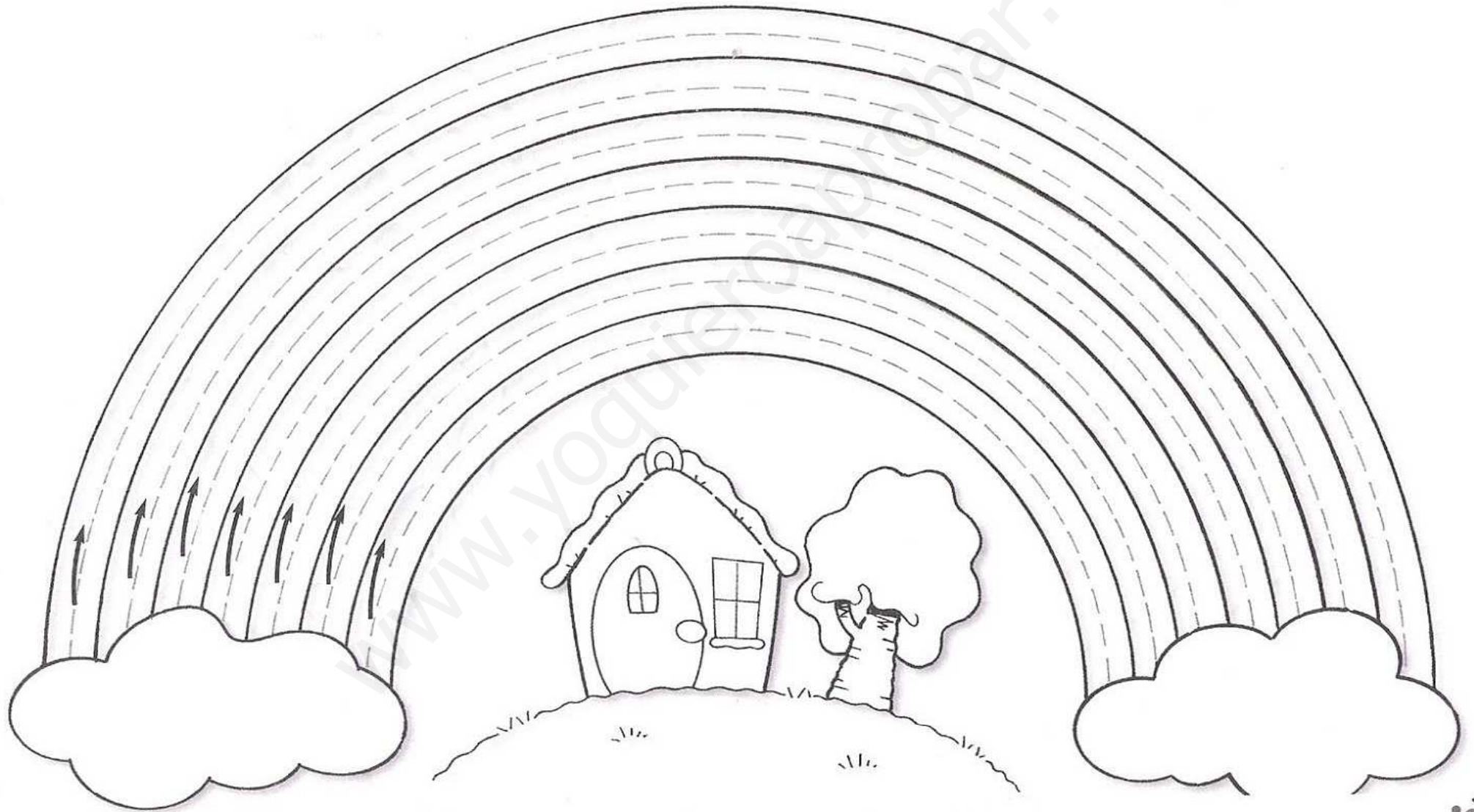

SIGUE

Termina la casa del caracol siguiendo la dirección de la flecha.

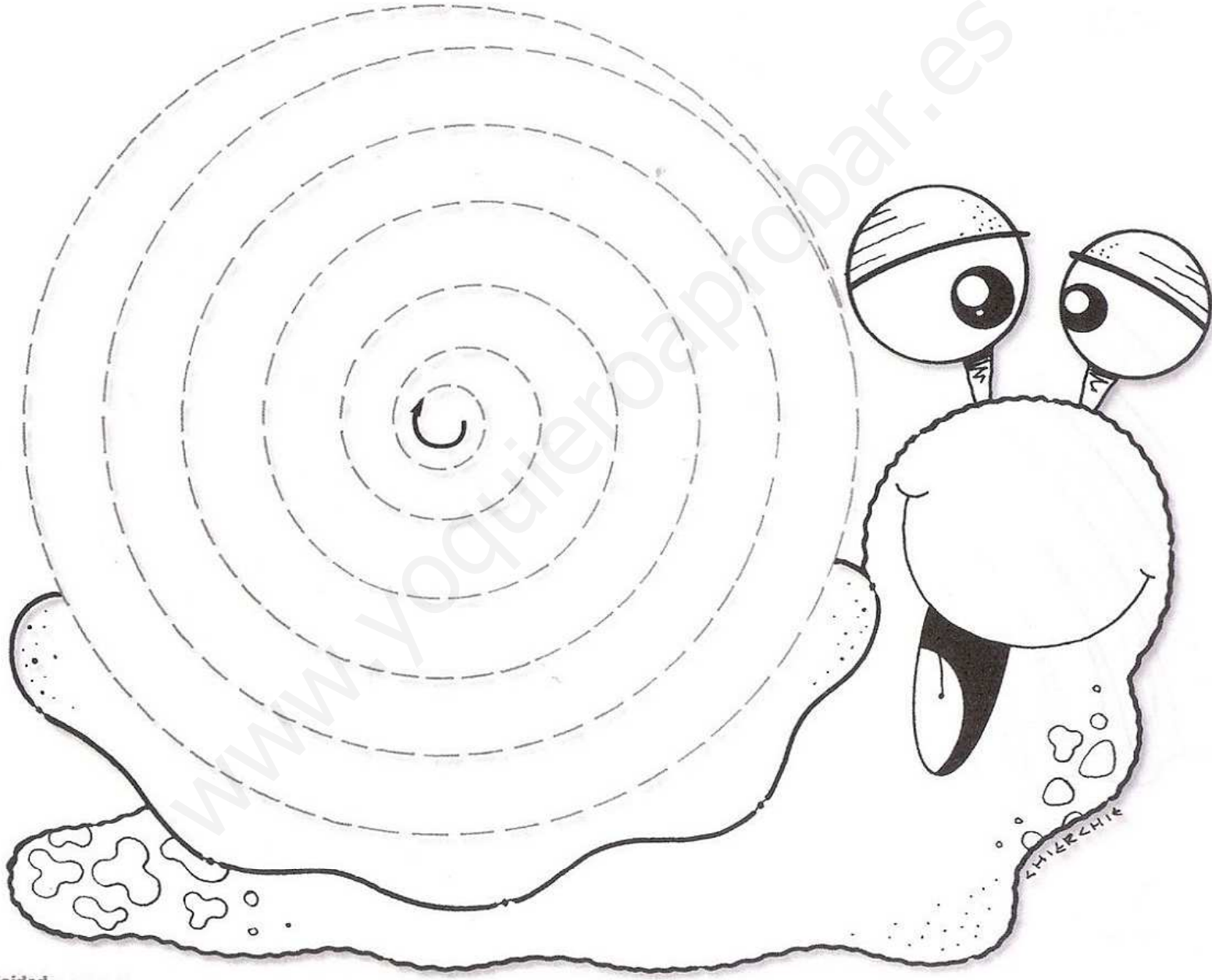

¿TE ANIMAS

a dibujar las hélices del helicóptero con la ayuda de las flechas?

Grafomotricidad inicial
13

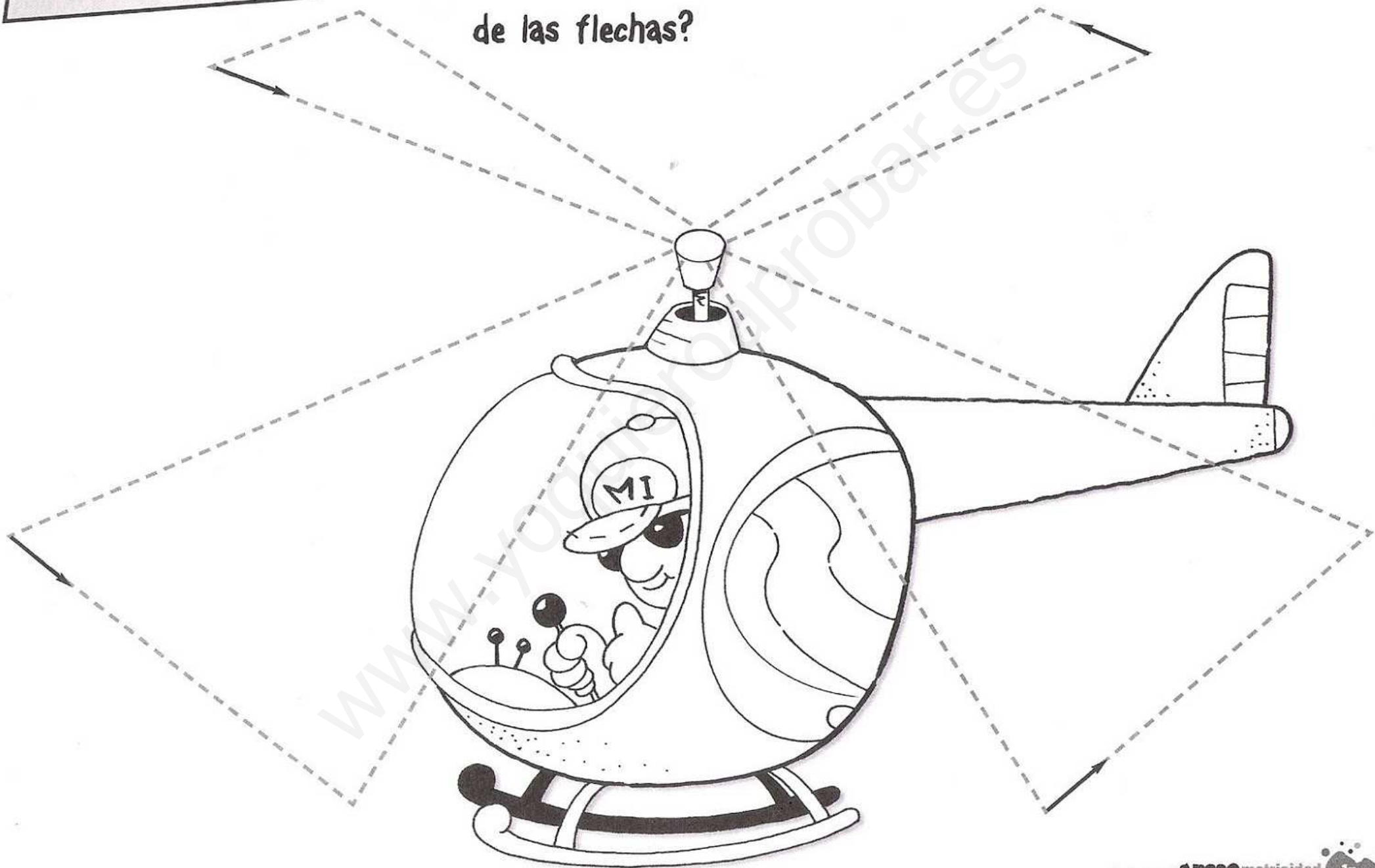

SIGUE las líneas de la lluvia.

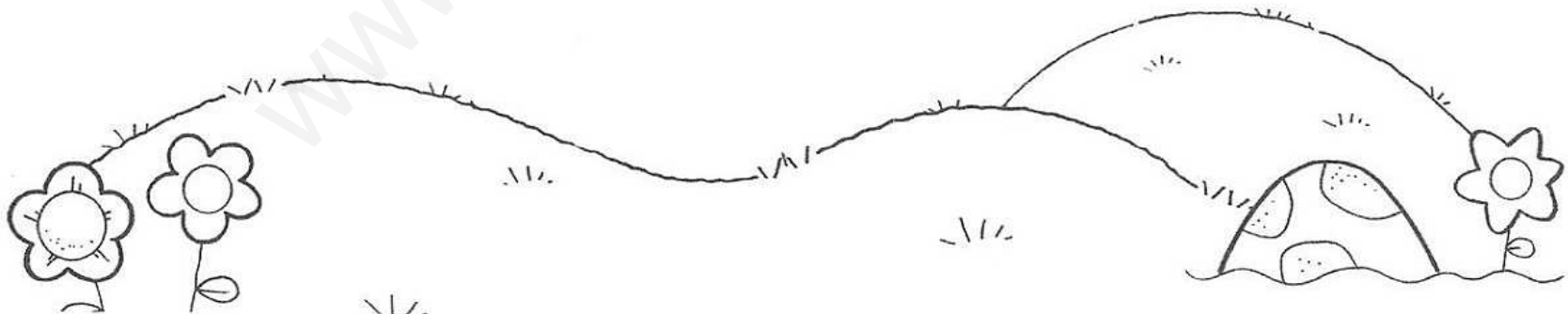
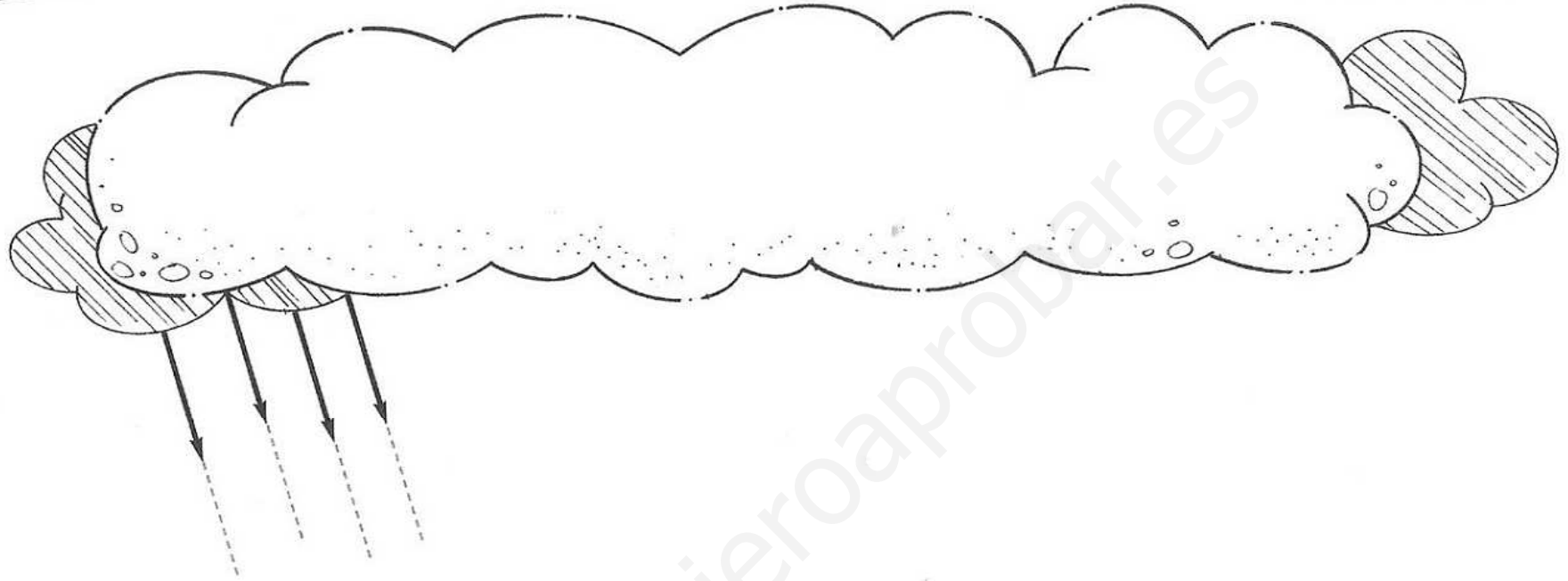

DIBUJA

la tela de araña siguiendo la flecha.

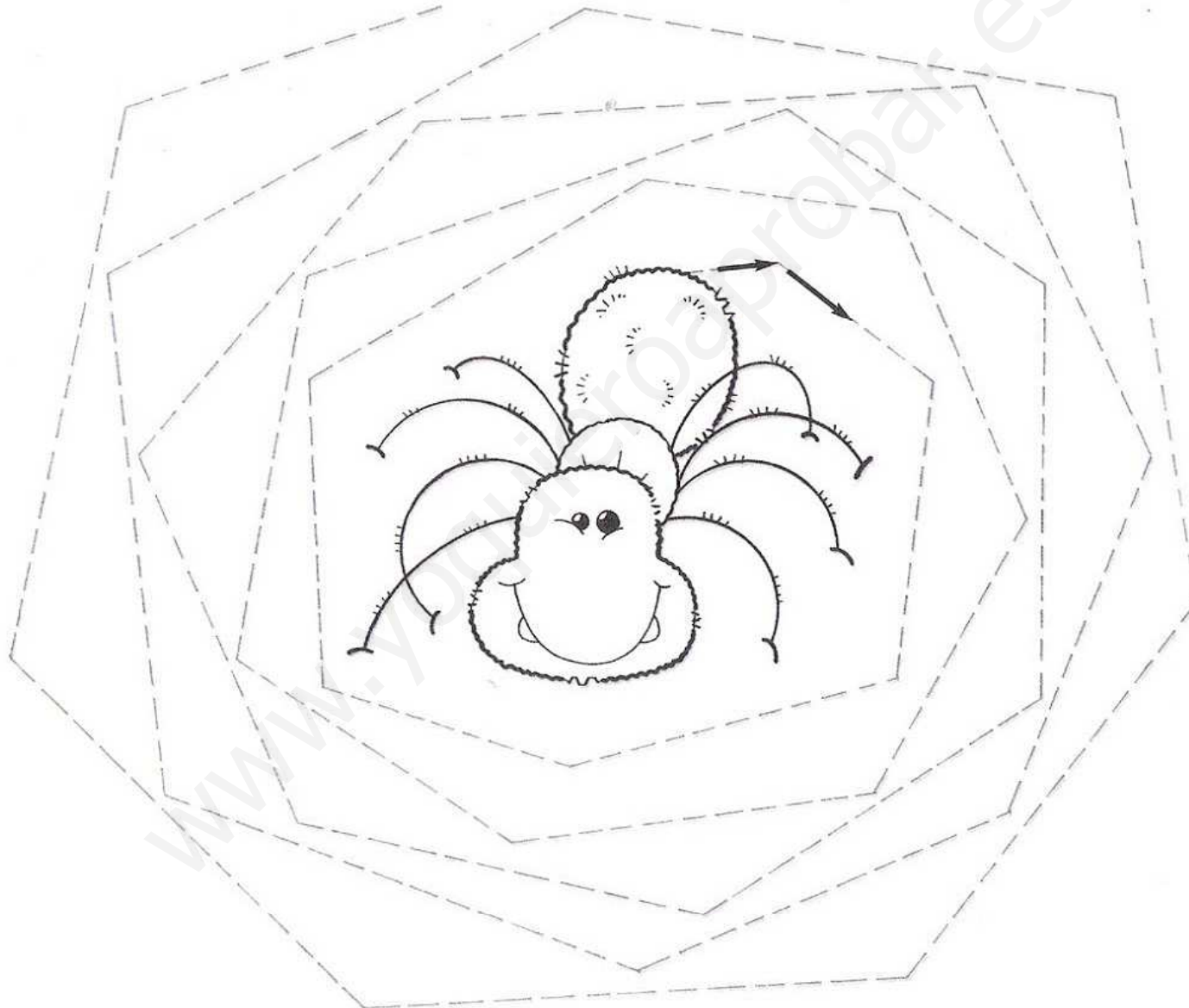

CUENTA

los animalitos que aparecen en cada fila y traza una línea desde la fila a la cantidad que has obtenido.

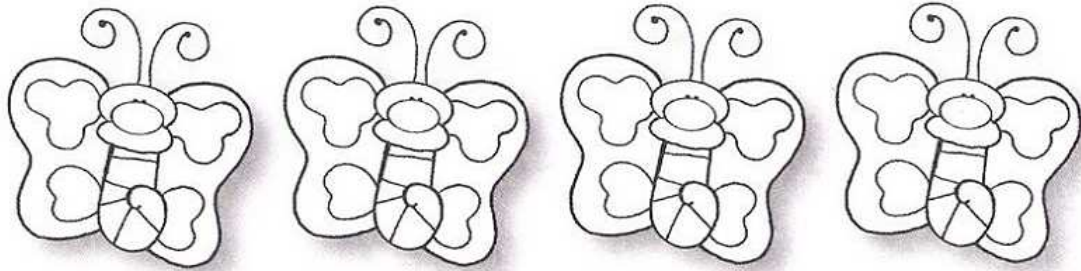

1

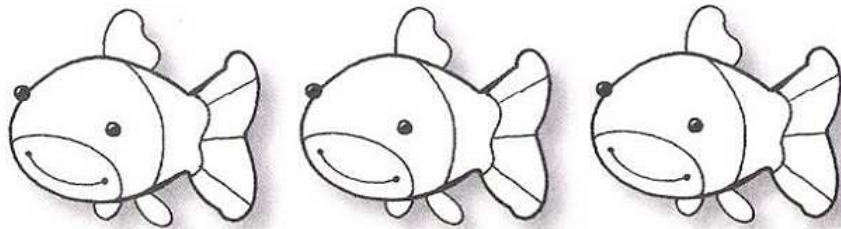

2

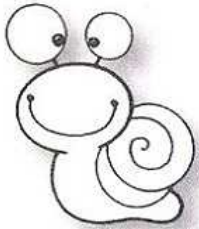

3

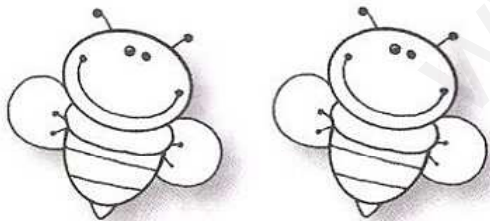

4

www.yoquieroaprobar.es

¿QUÉ

recorridos deberán hacer estas hormigas para llegar a los huevos?

Grafomotricidad inicial

17

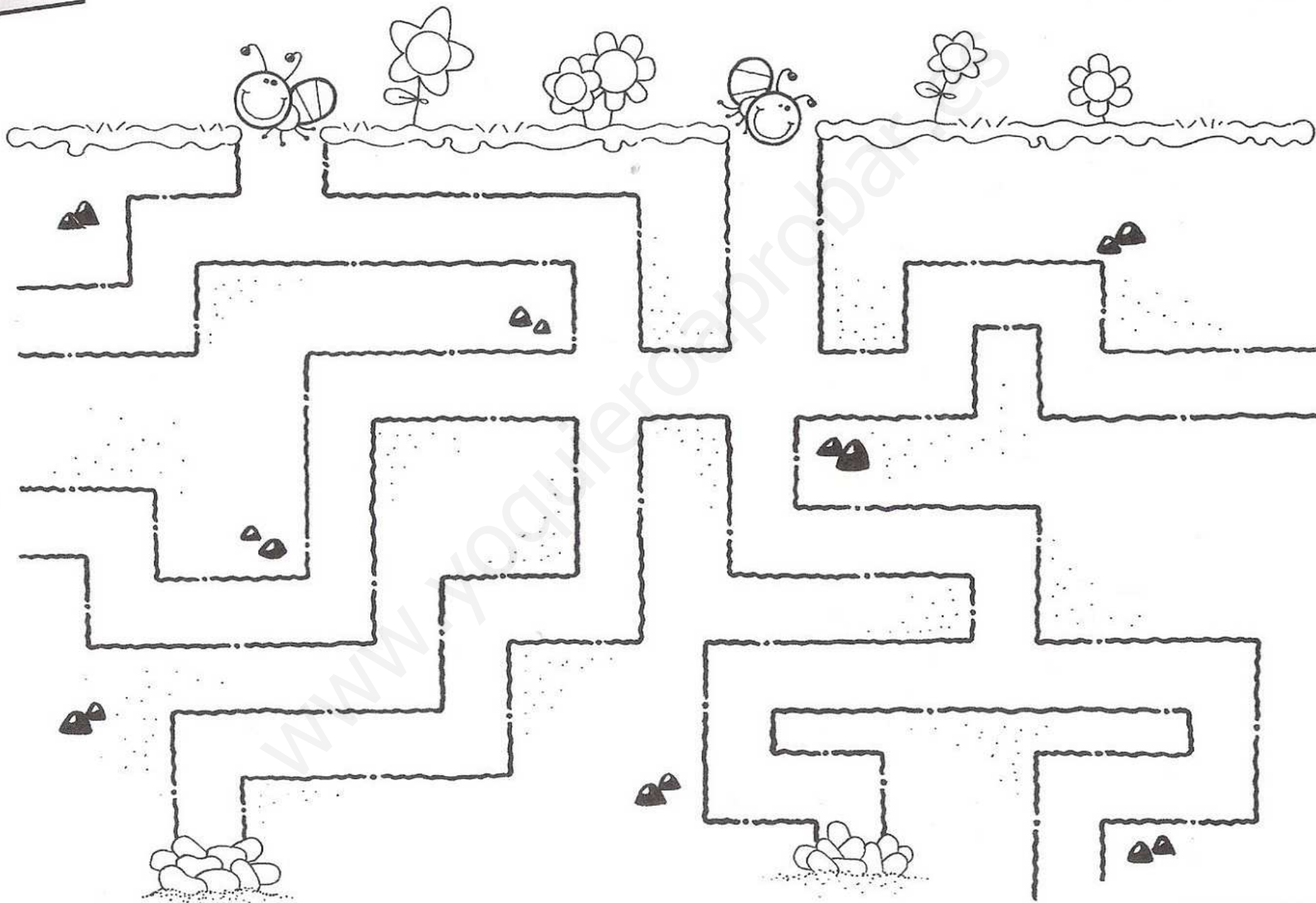

COMPLETA

el camino con burbujas siguiendo las flechas.

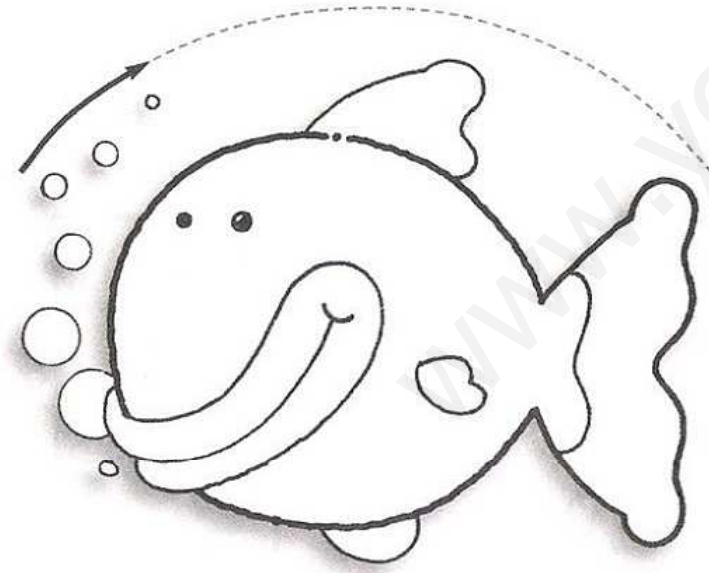
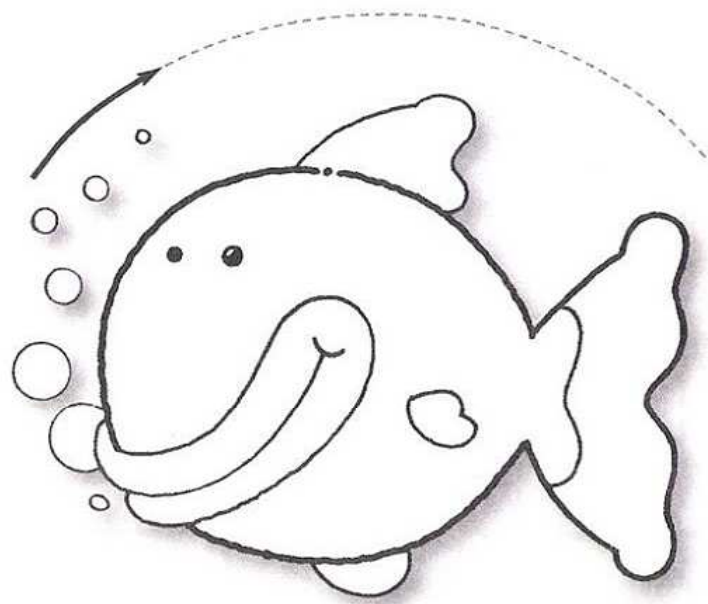

www.loquieroaprobar.es



con lápiz los trazos de línea discontinua siguiendo la dirección de las flechas.

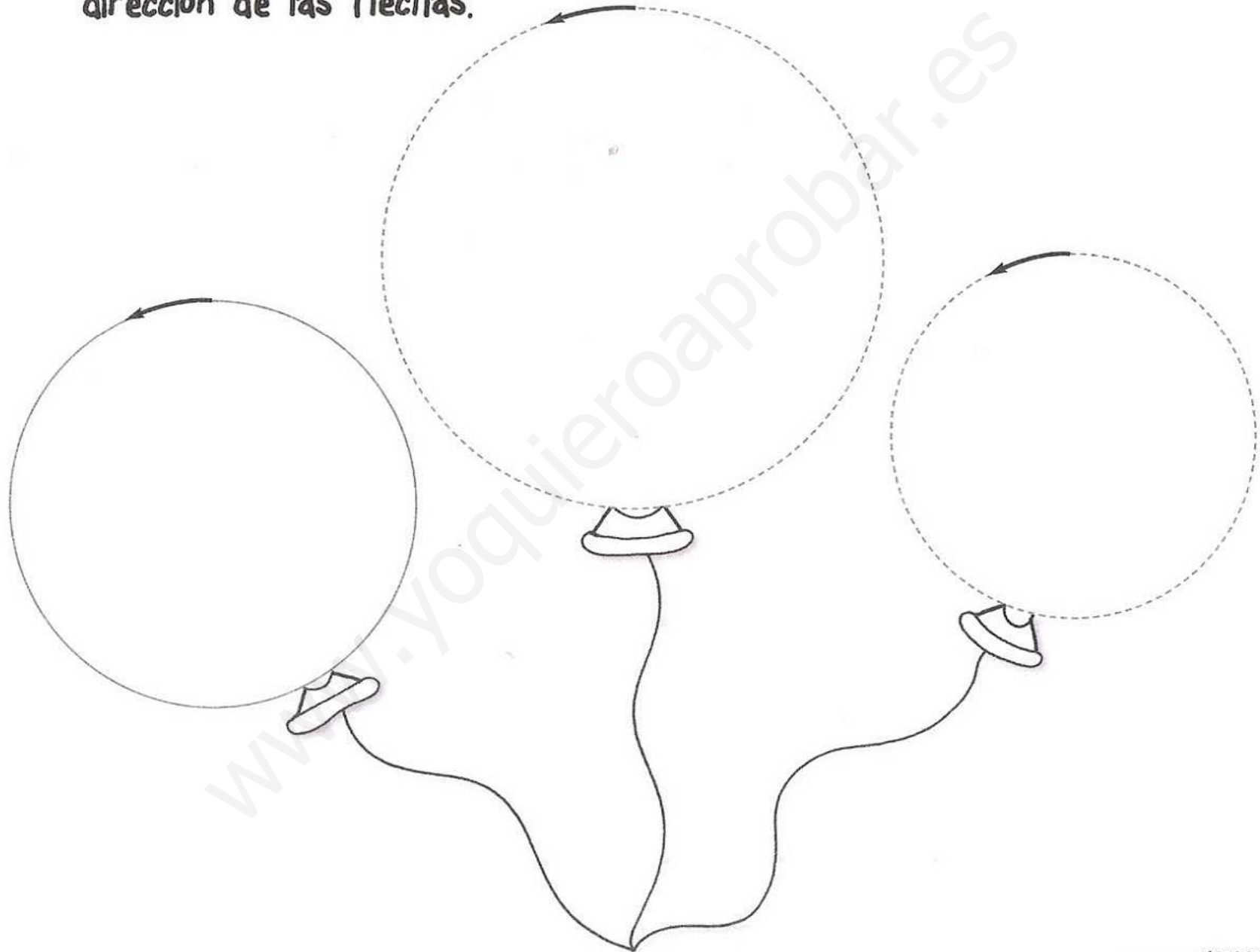



UNE los puntos.



www.yoquieroaprobar.es

COMPLETA

el dibujo del Sol y traza el camino de cada animalito hasta llegar al punto.

Grafo motricidad inicial 21

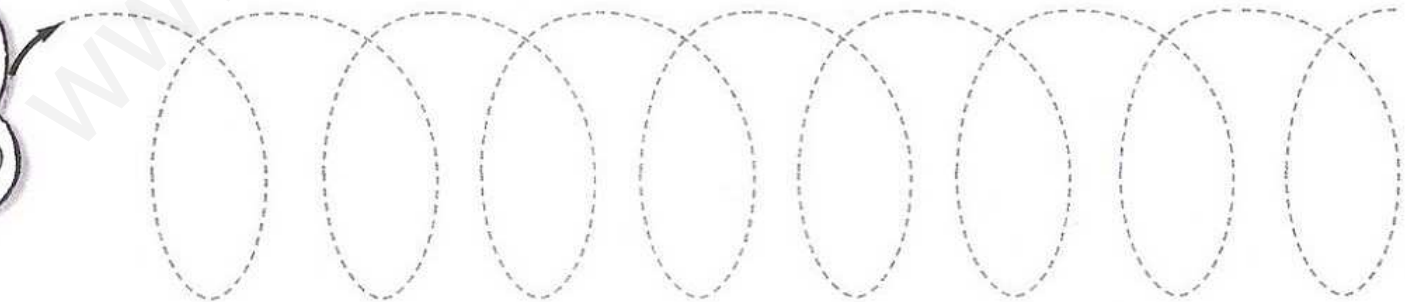
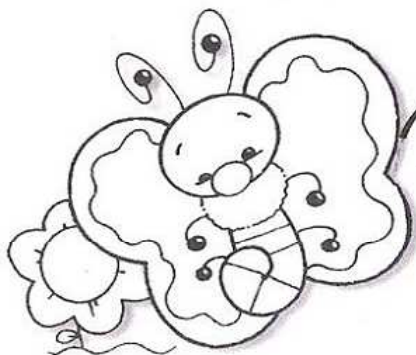
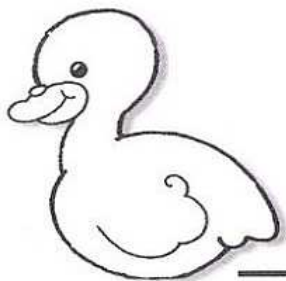
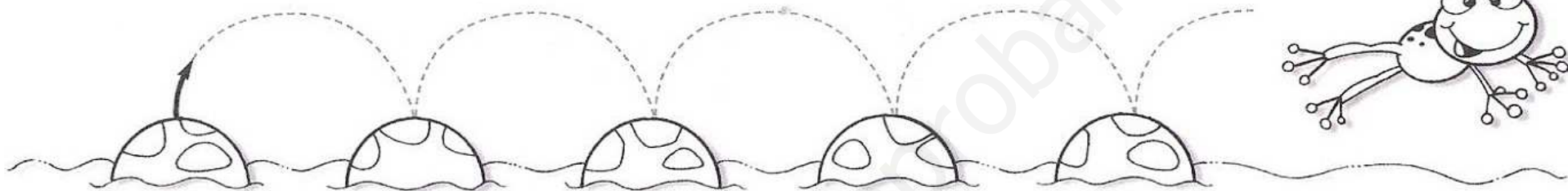
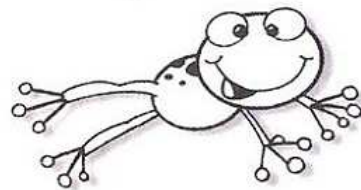

DECORAMOS los calcetines siguiendo las flechas.

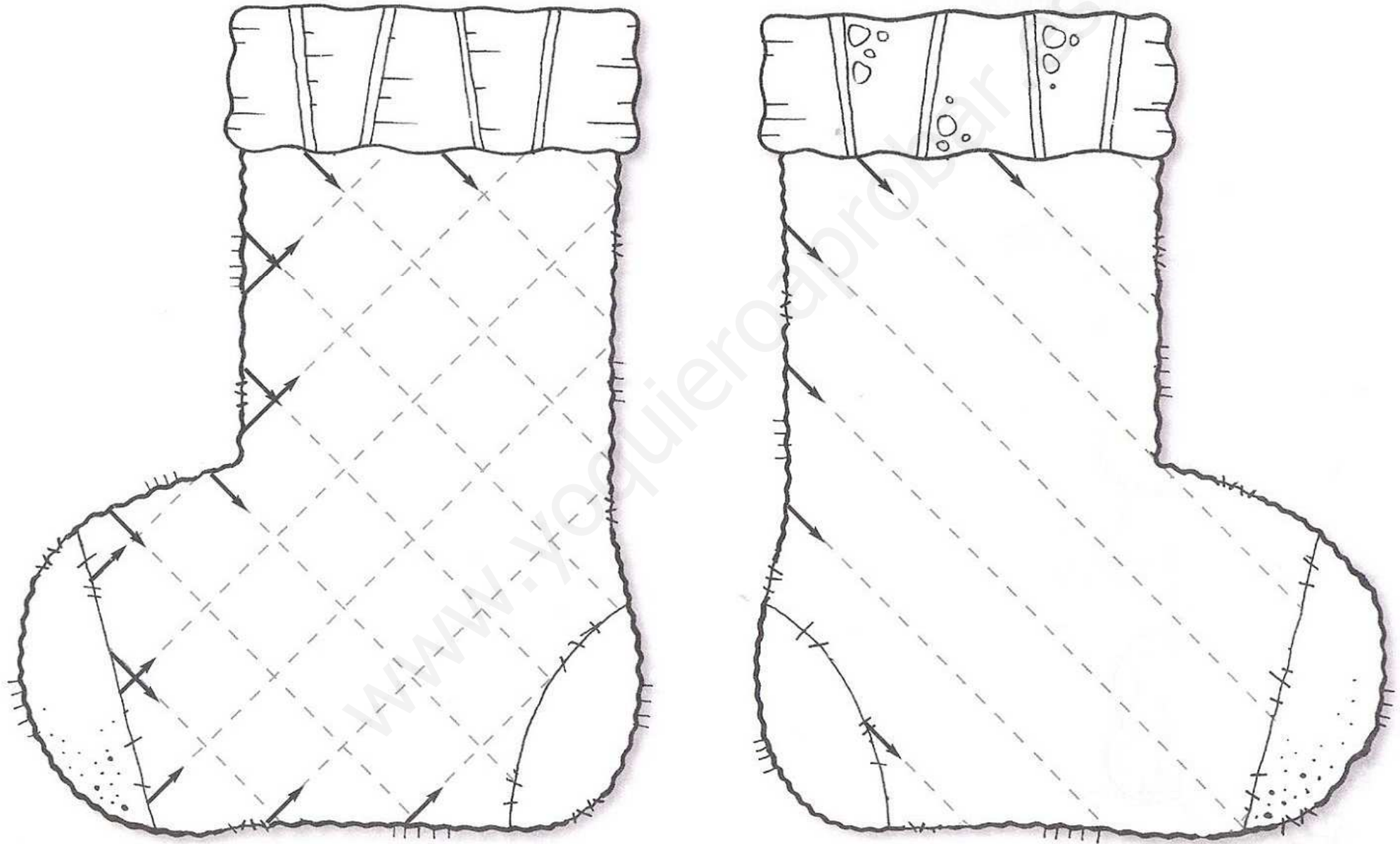

DIBUJA

el globo siguiendo la dirección de la flecha





las ruedas de la bicicleta siguiendo las flechas.



COLOREA

las cuentas que le faltan al collar de la niña.



SIGUE la dirección de la flecha y repasa con un lápiz
la línea discontinua hasta llegar al punto.

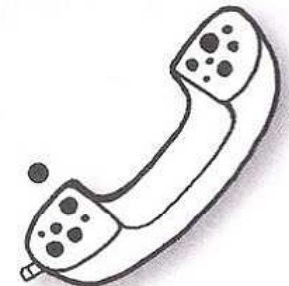
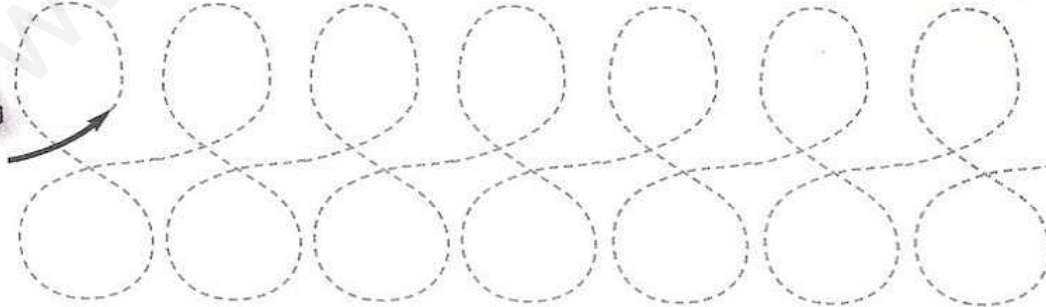
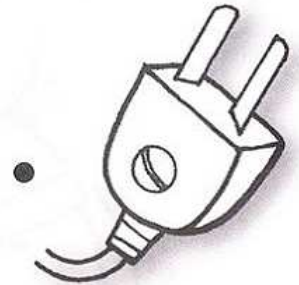
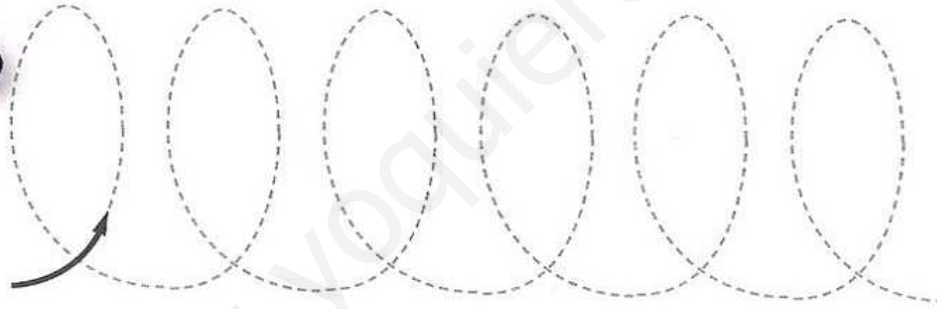
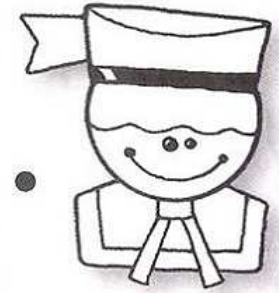
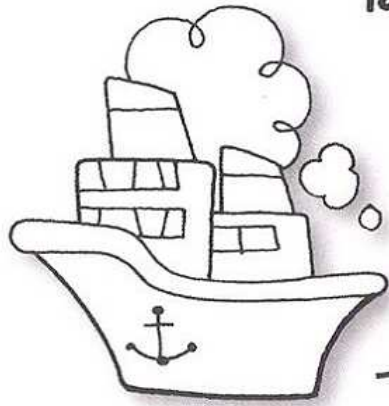

COMPLETA

el helado siguiendo las flechas.

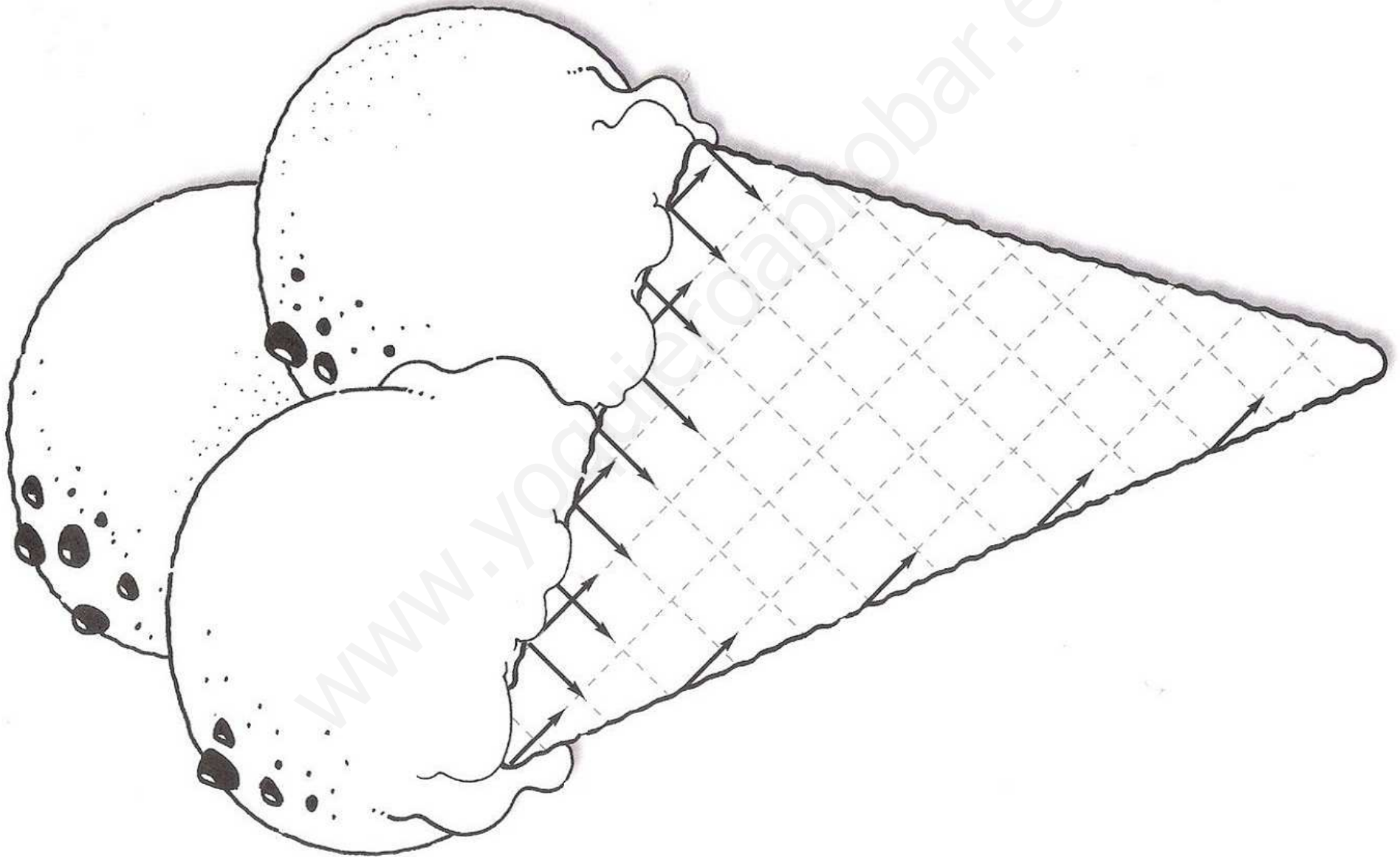

DI BUJA

el recorrido de la rueda y el recorrido del hilo de la cometa
hasta llegar al punto.

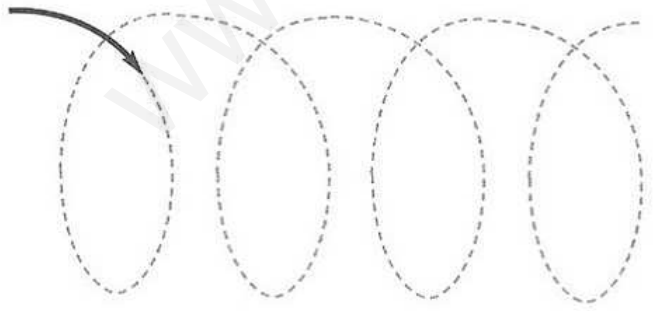
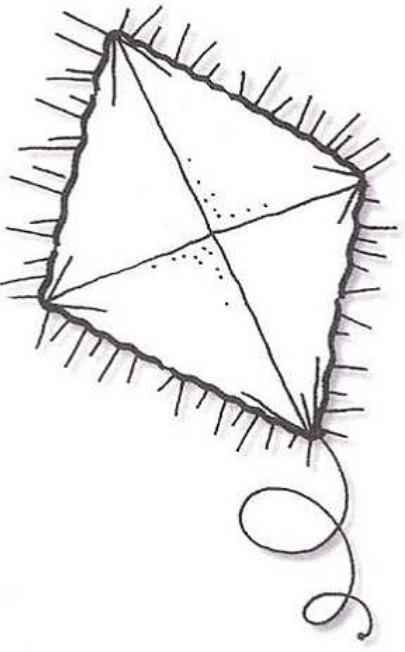
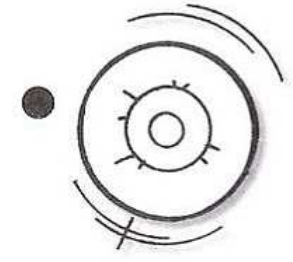
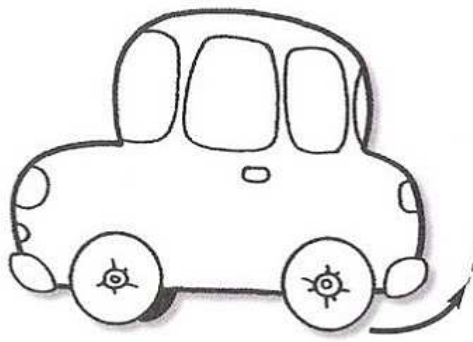

¿PUEDES

terminar de decorar el tiesto? Sigue siempre el sentido de las flechas hasta llegar al punto

Grafomotricidad inicial
29

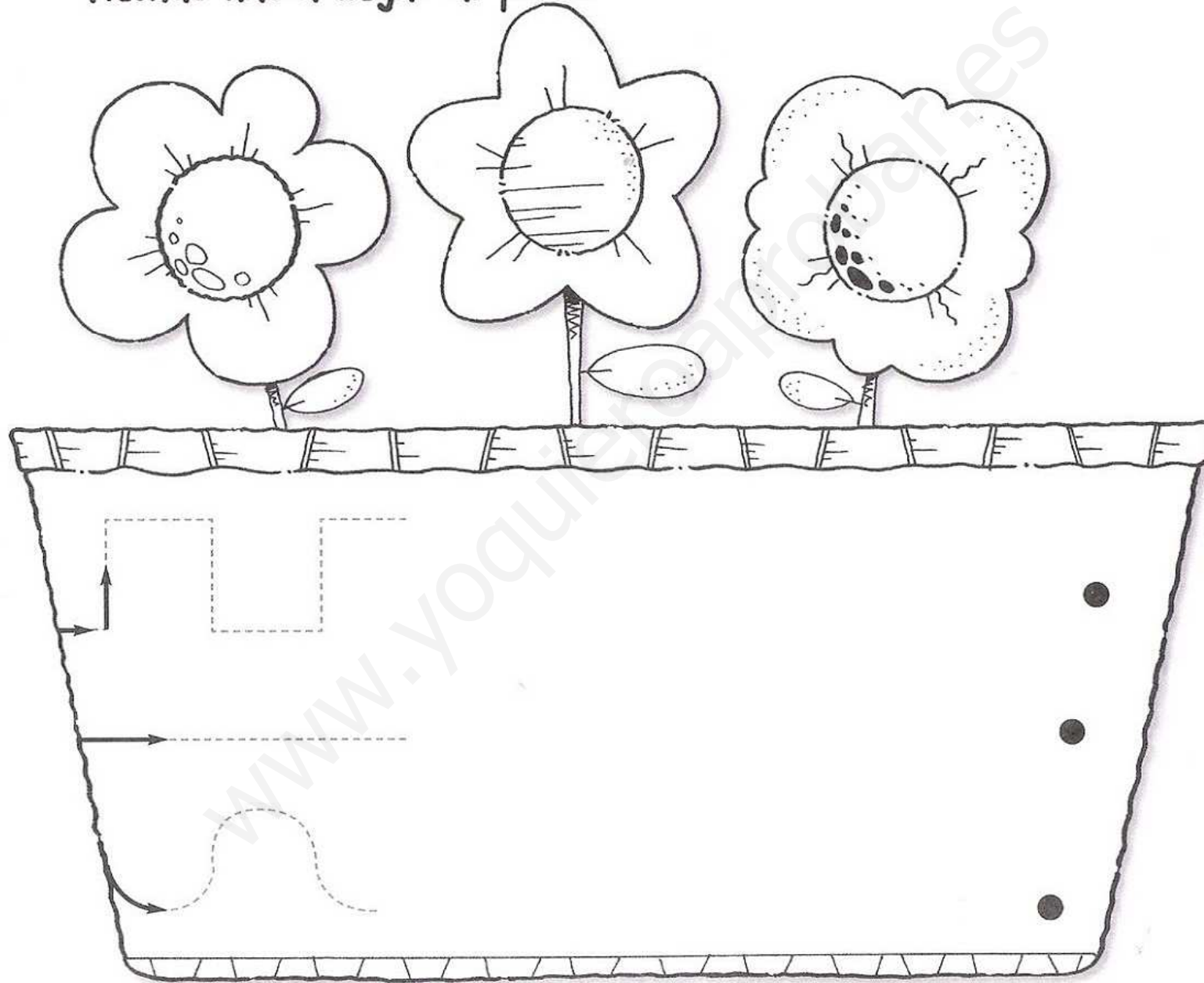

¡QUÉ

manta tan abrigada! ¿Te animas a terminar de decorarla?

Comienza
en la flecha
y termina
en el punto

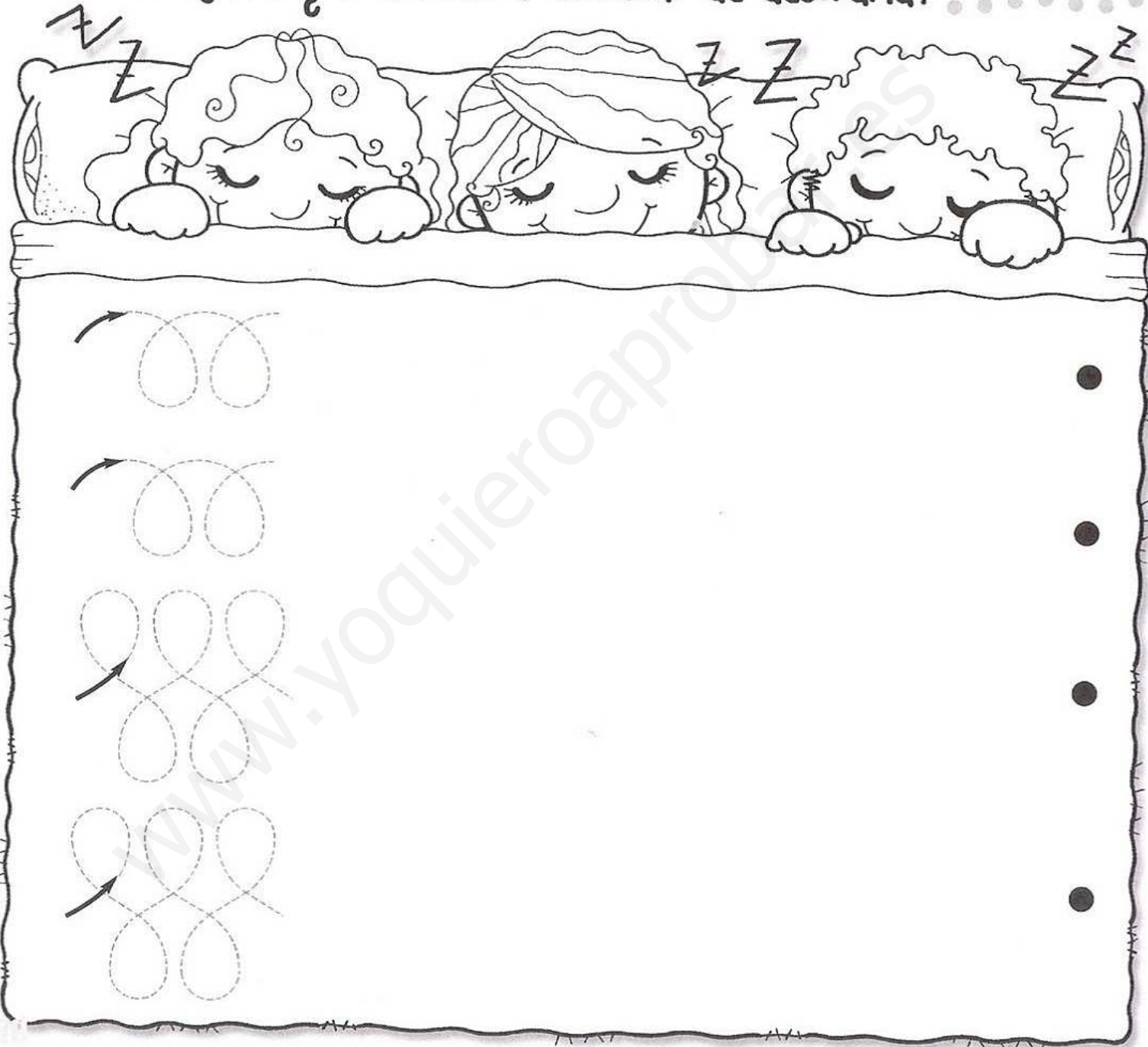

TRAZA

cada número siguiendo la dirección que te indica la flecha.

-Colorea, en cada ficha, tantos objetos como indica el número.

-Repasa con lápiz los números y después completa el renglón.

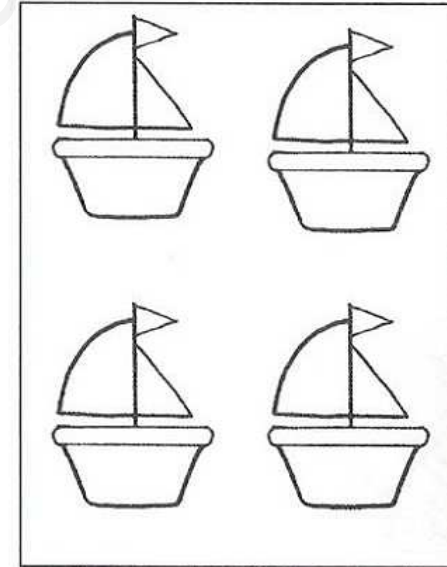
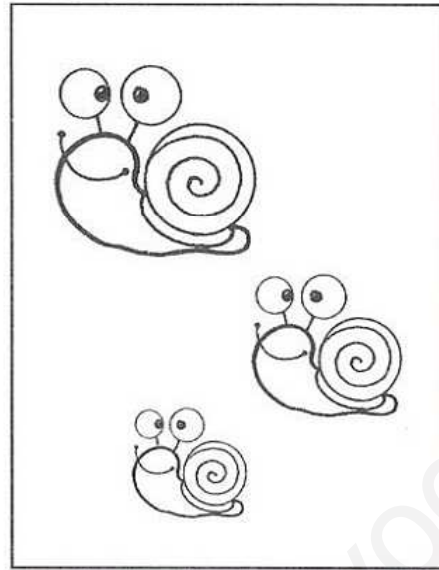
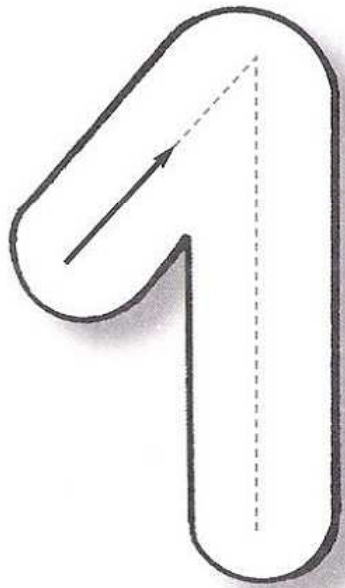

EDUCACIÓN INFANTIL

5º CURSO

Grafomotricidad 2

www.yoquieroaprender.es

Nombre:



Tarea: Limitamos el espacio. Solo arriba.
Técnica: Colorear con ceras duras y picado

Fecha:

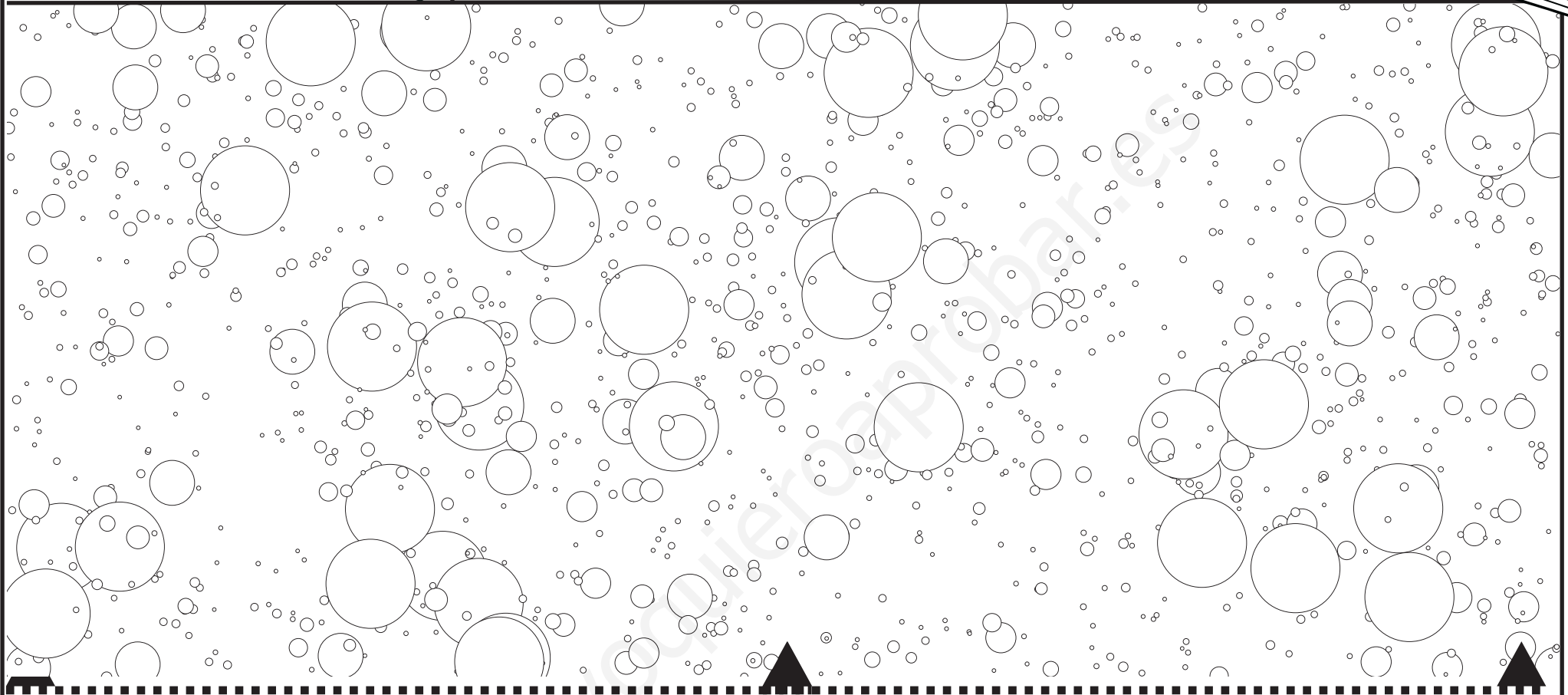

Nombre:



Tarea: Limitamos el espacio. Sólo abajo
Técnica: Colorear con ceras duras y picado

Fecha:

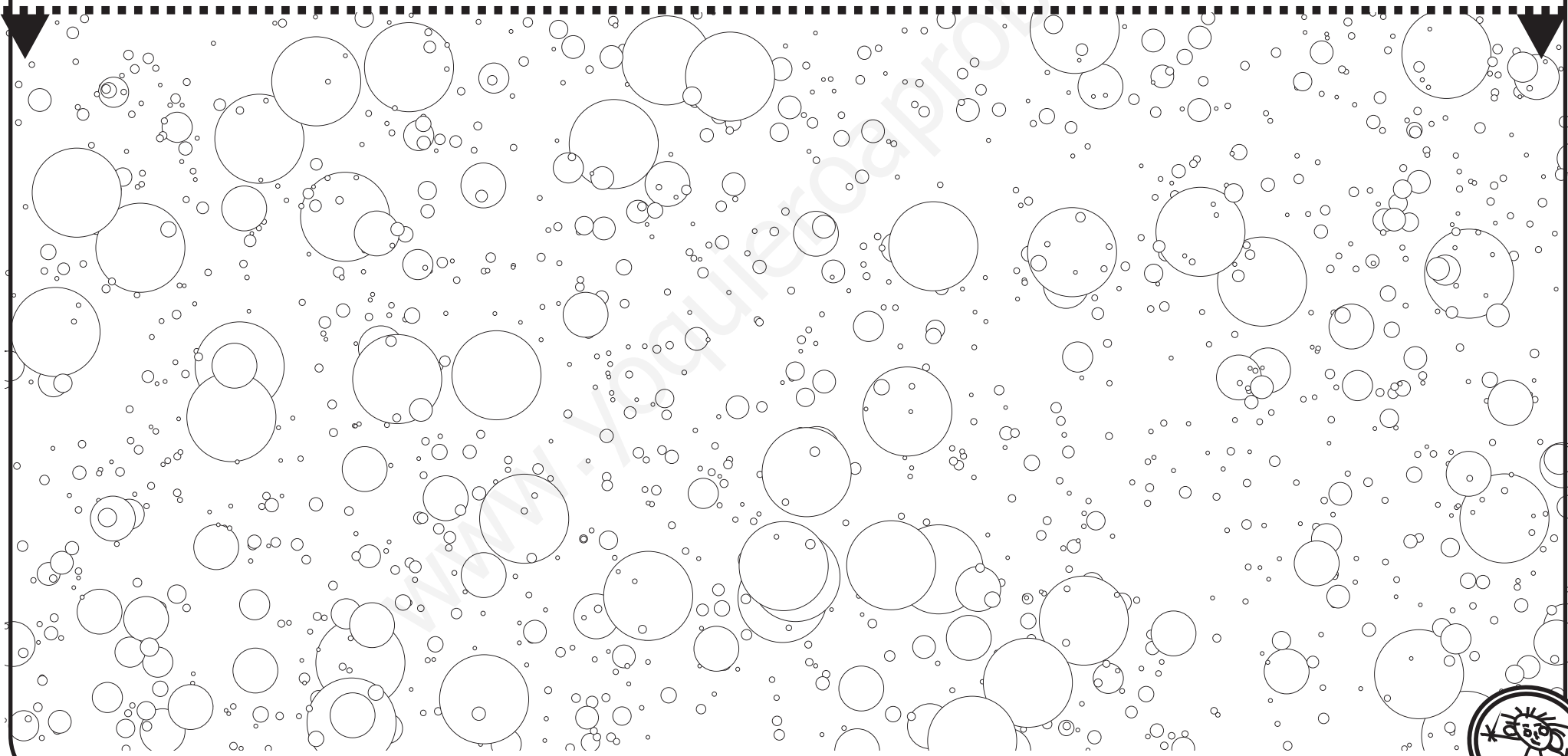
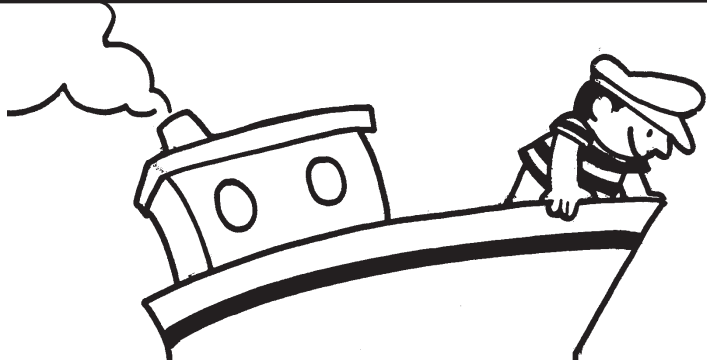

Nombre:



Tarea: Limitamos el espacio. Sólo izquierda y derecha
Técnica: Colorear con ceras duras y picado

Fecha:

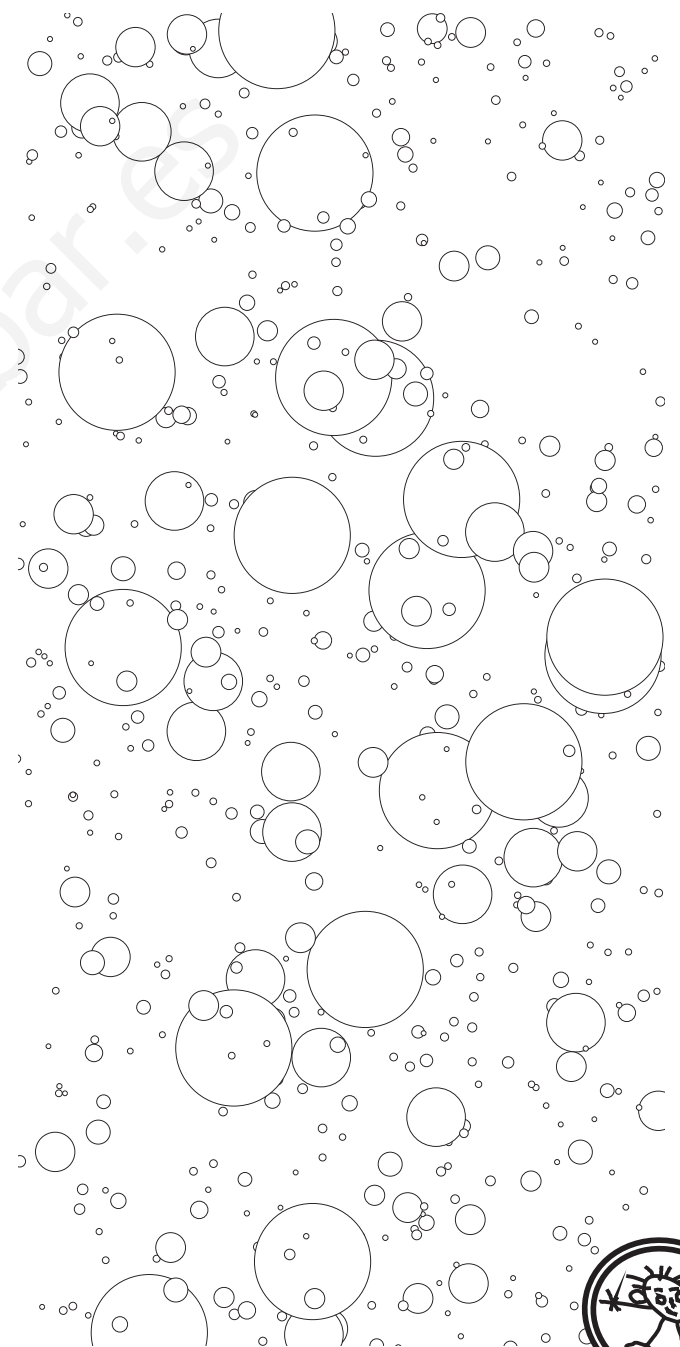
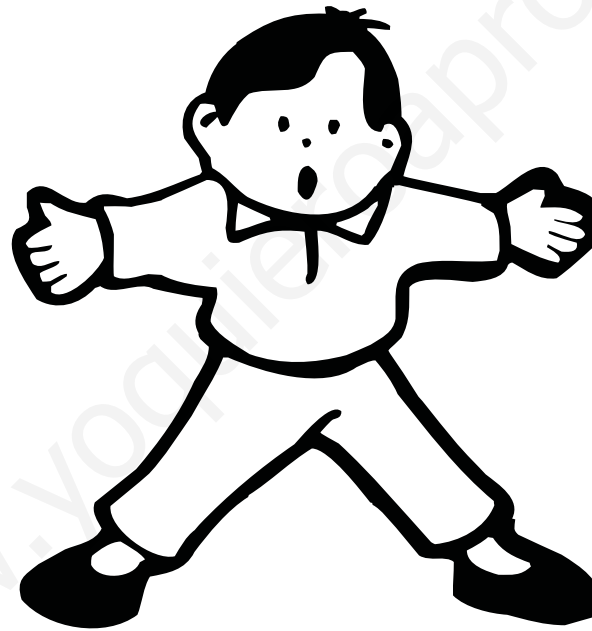
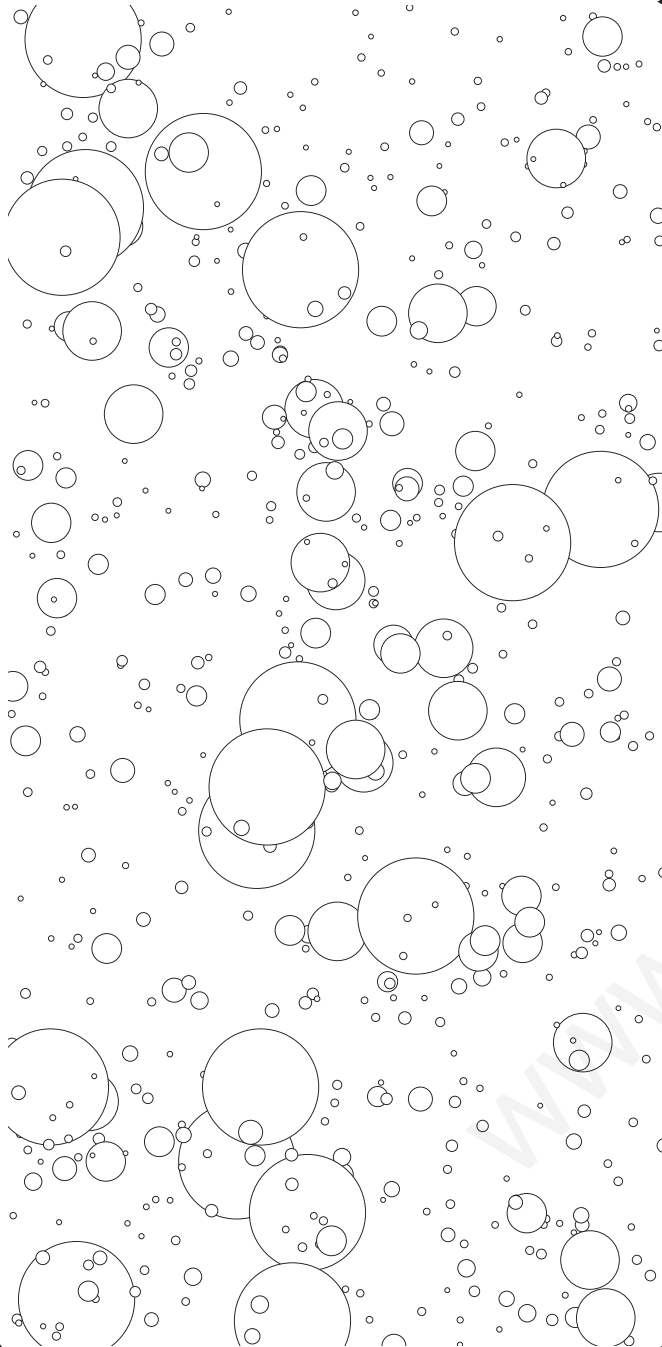

Nombre:



Tarea: Limitamos el espacio. Sólo el espacio delimitado.
Técnica: Colorear con ceras duras y picado

Fecha:

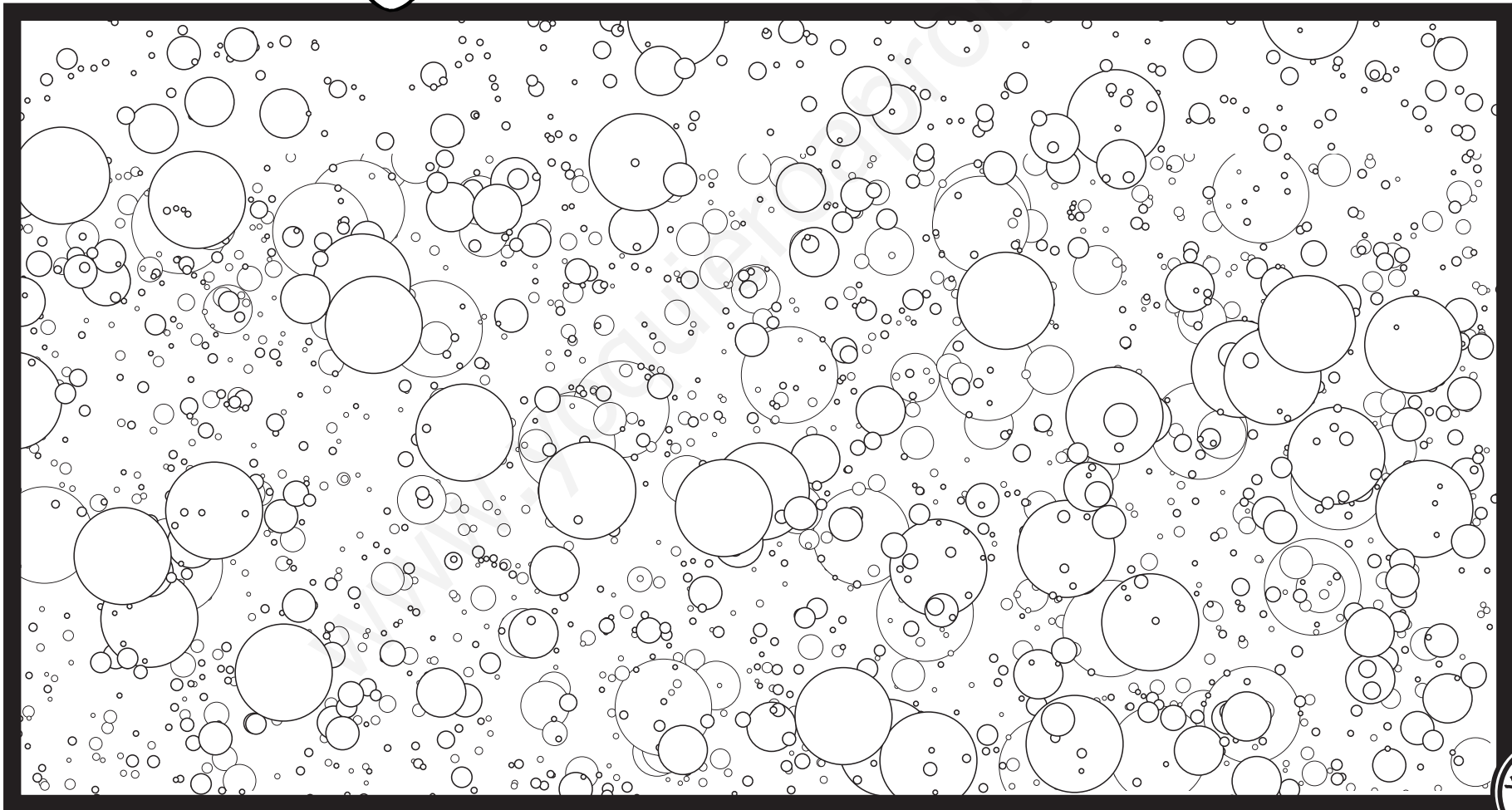
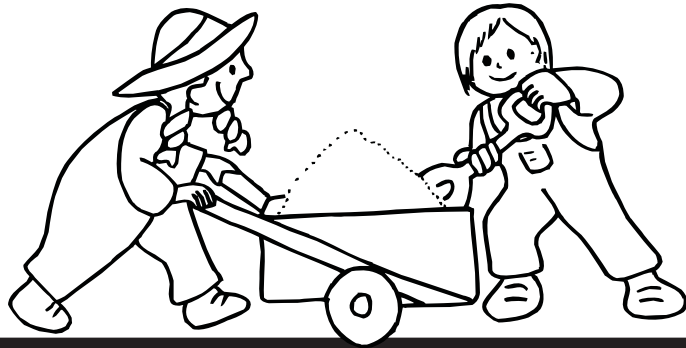

Nombre:



Tarea: Trazamos verticales de arriba hacia abajo
Técnica: Colorear con ceras duras.

Fecha:

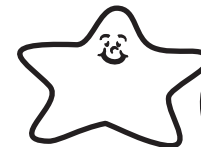
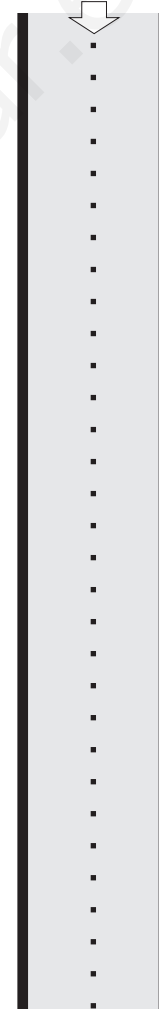
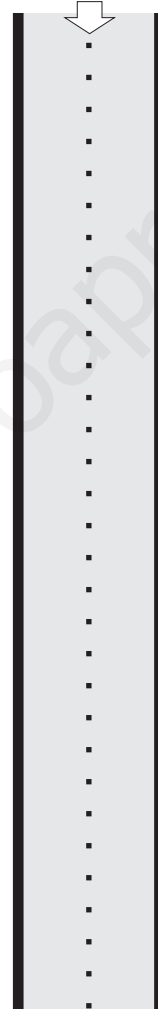
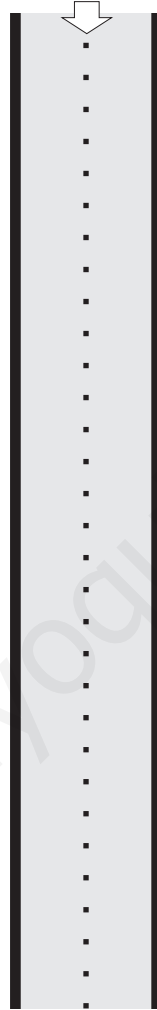
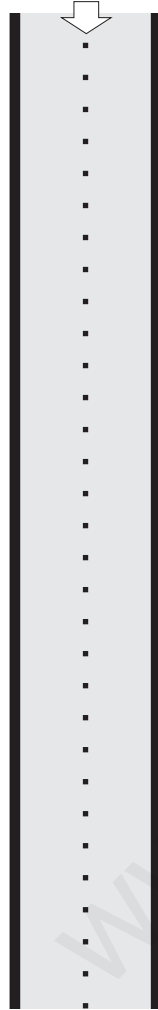
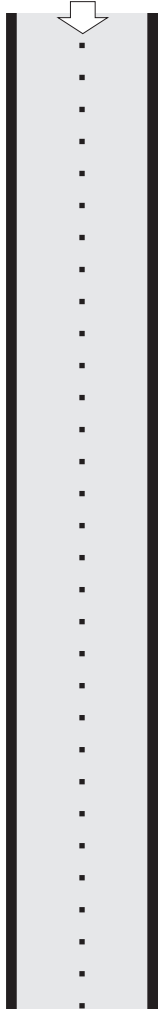
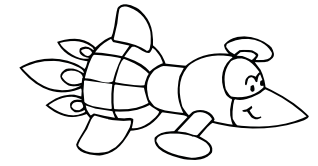
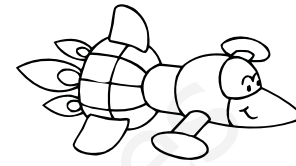
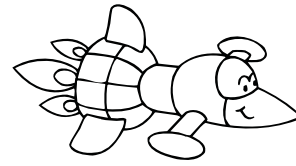
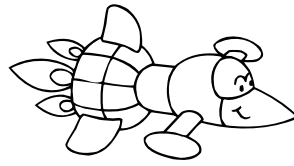
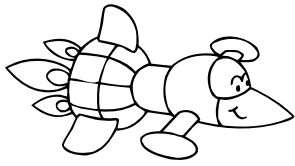
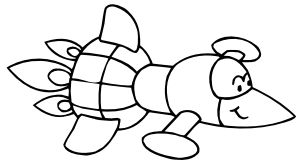

Nombre:



Tarea: Trazamos verticales de arriba hacia abajo
Técnica: Colorear con ceras duras.

Fecha:

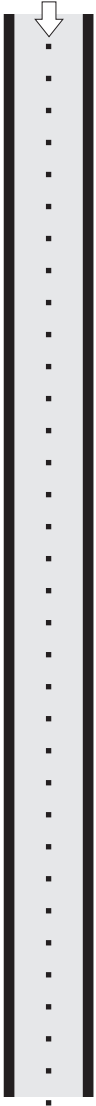

Nombre:



Tarea: Trazamos verticales de arriba hacia abajo
Técnica: Colorear con ceras duras

Fecha:

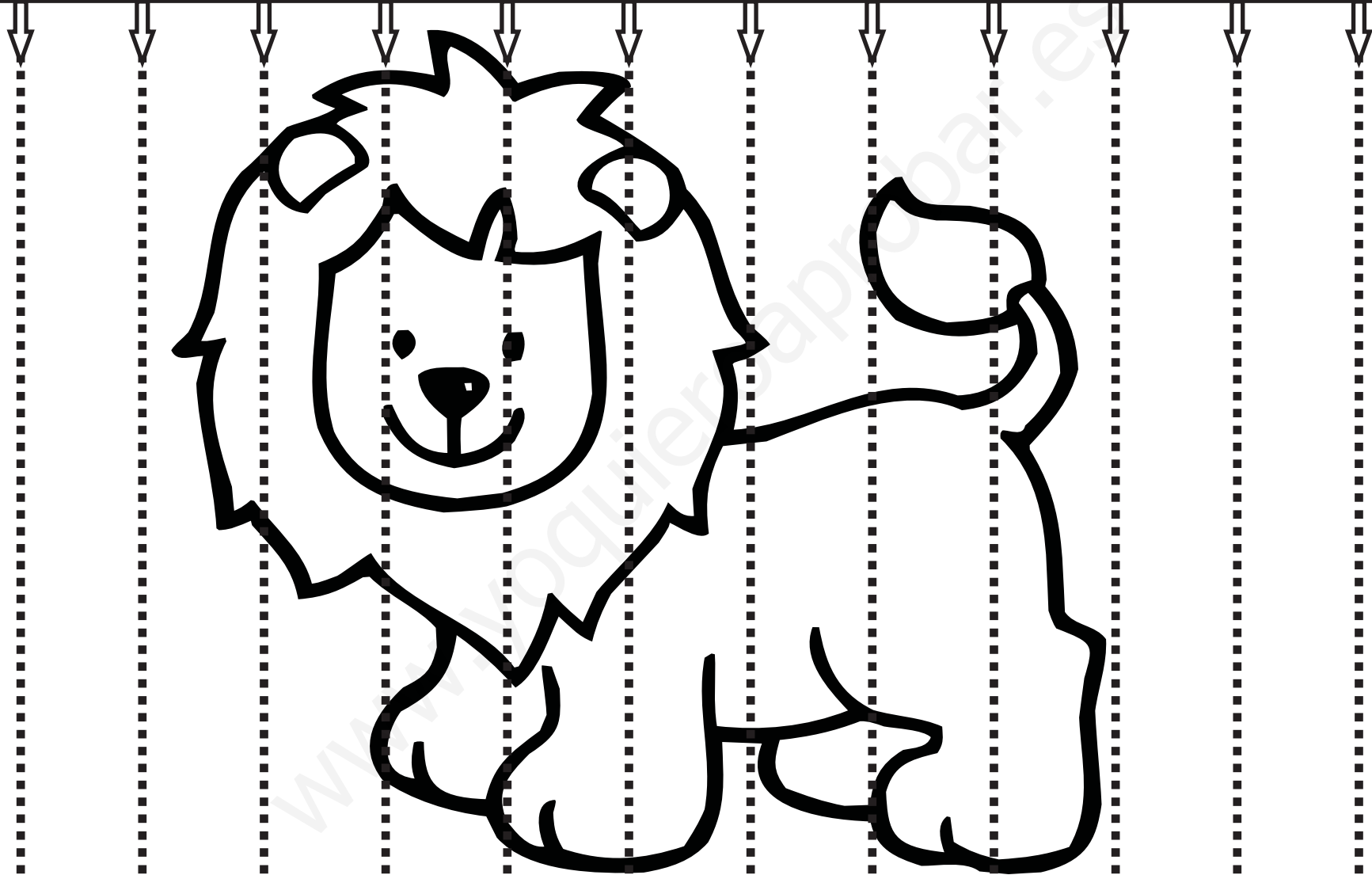

Nombre:



Tarea: Trazamos verticales de arriba hacia abajo
Técnica: Colorear con ceras duras.

Fecha:

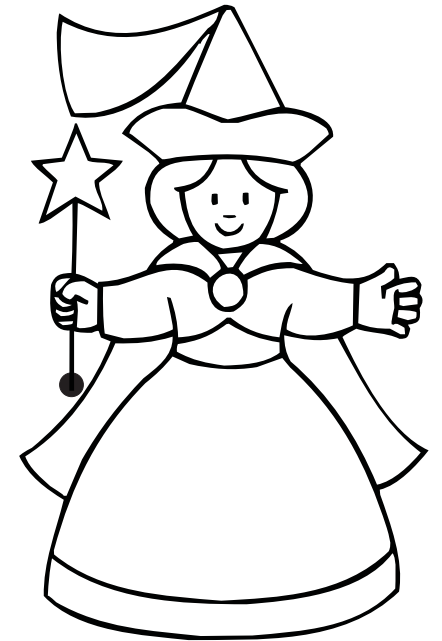
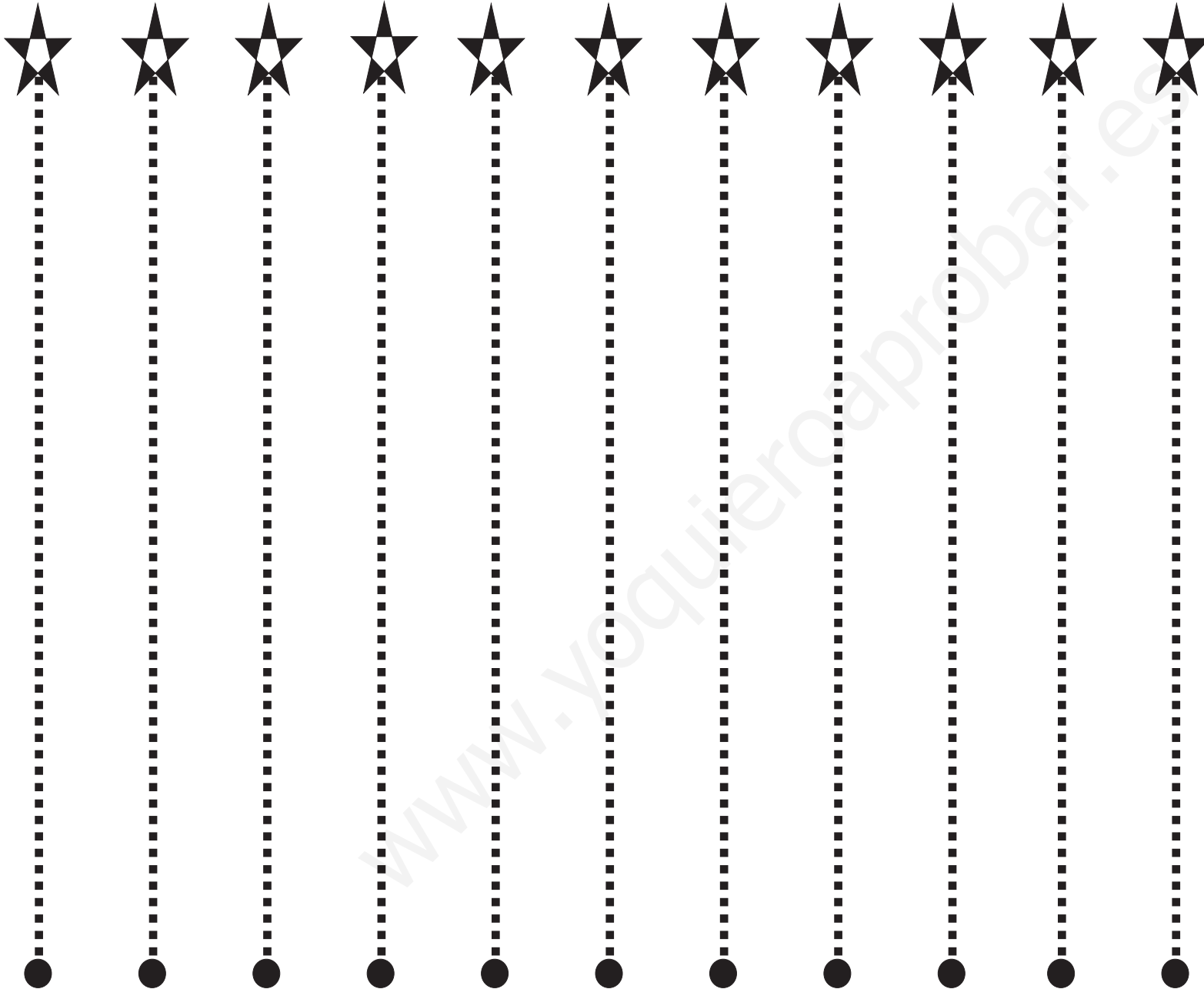

Nombre:



Tarea: Trazamos caminos. Horizontales
Técnica: Colorear con ceras duras y picar.

Fecha:

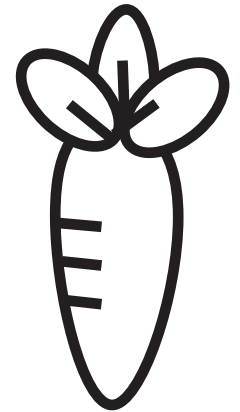
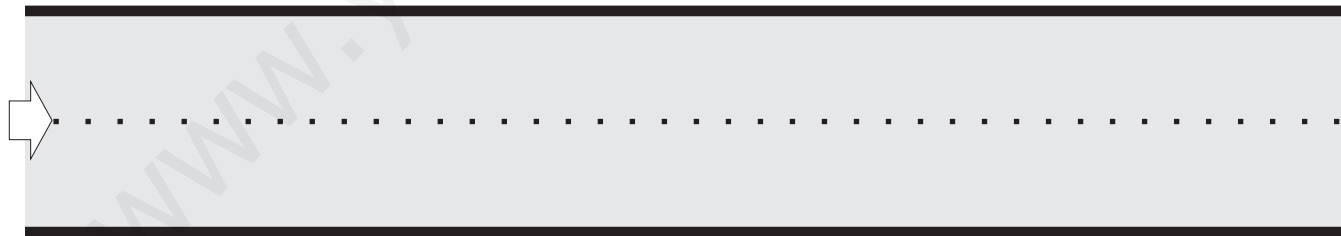
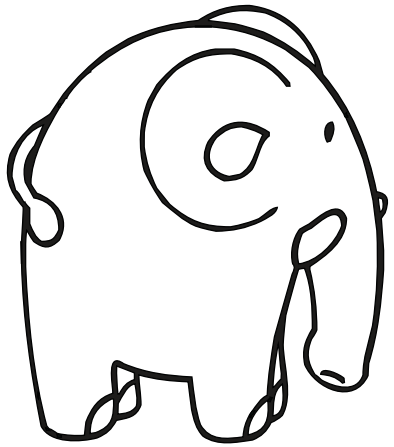
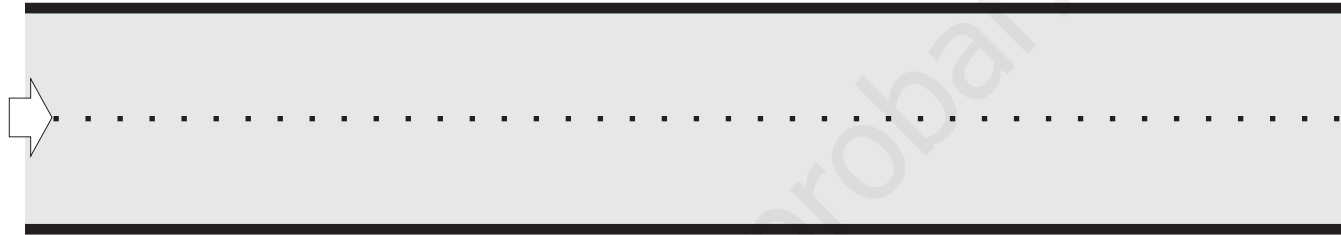

Nombre:



Tarea: Trazamos caminos. Horizontales
Técnica: Colorear con ceras duras y picar.

Fecha:

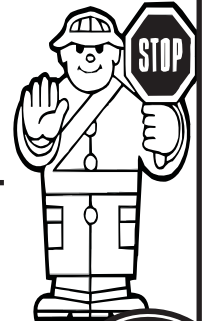
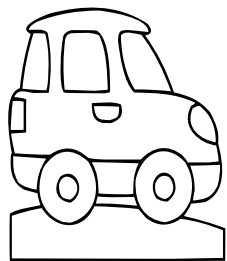
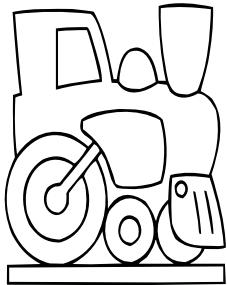
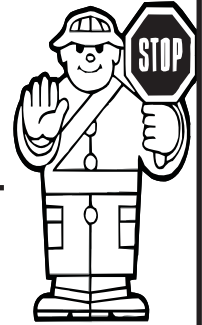
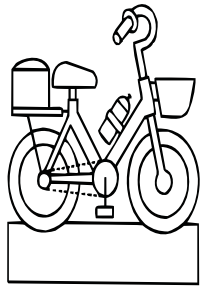

Nombre:



Tarea: Trazamos horizontales de izquierda a derecha
Técnica: Colorear con ceras duras.

Fecha:

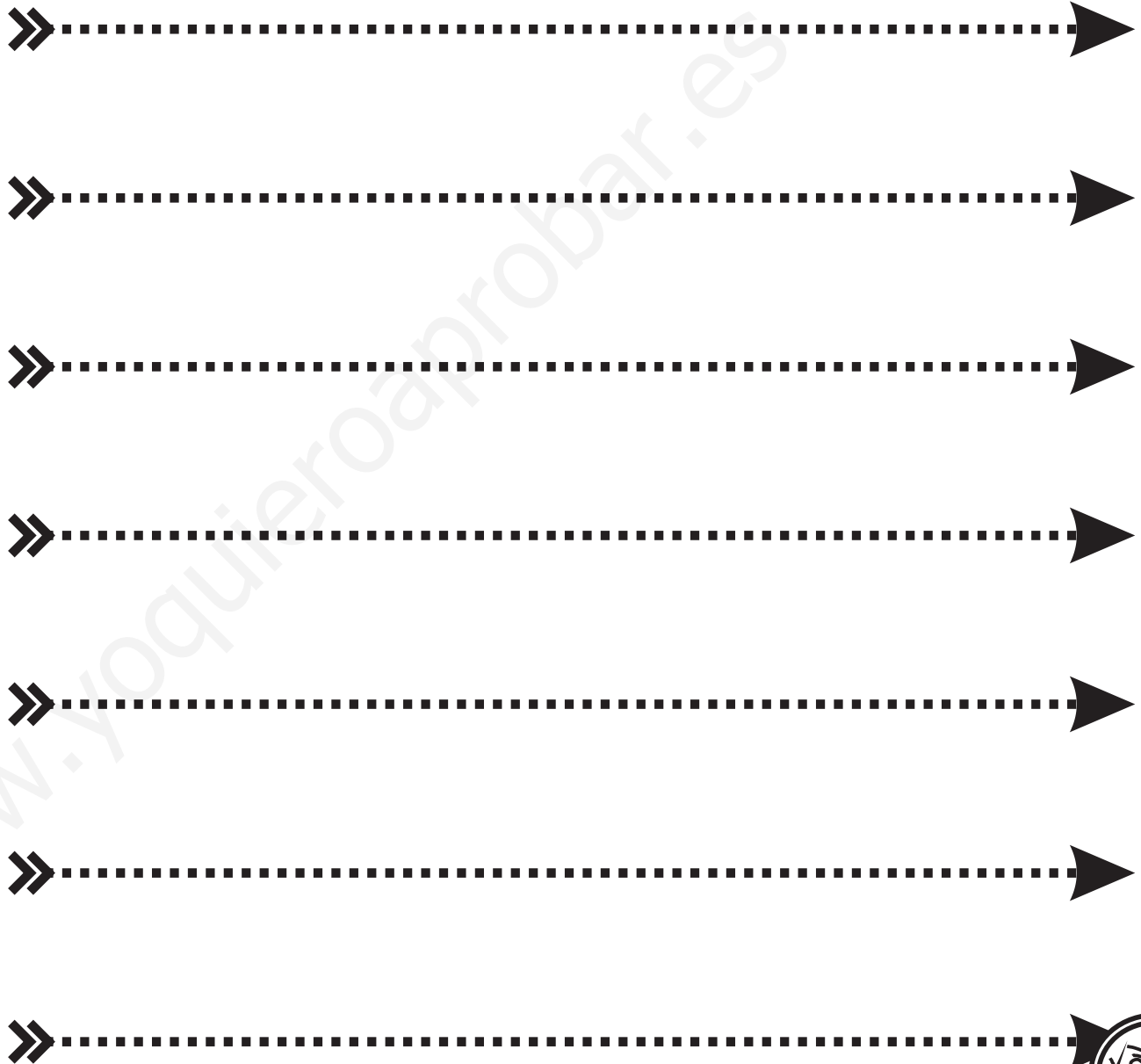

www.yoquieroaprobar.es



Jose Alberto

Nombre:



Tarea: Trazos verticales y horizontales
Técnica: Colorear con ceras duras.

Fecha:

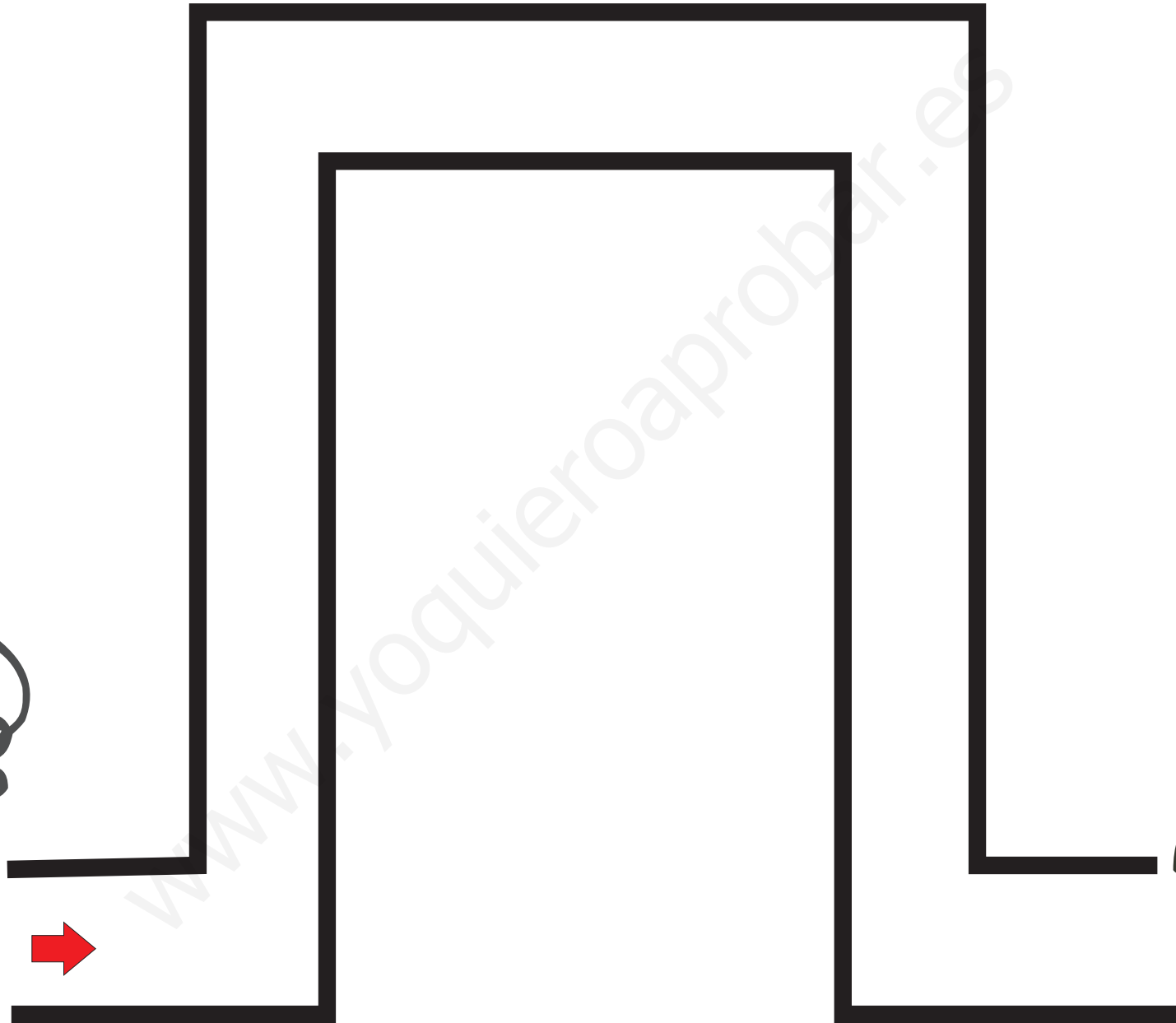
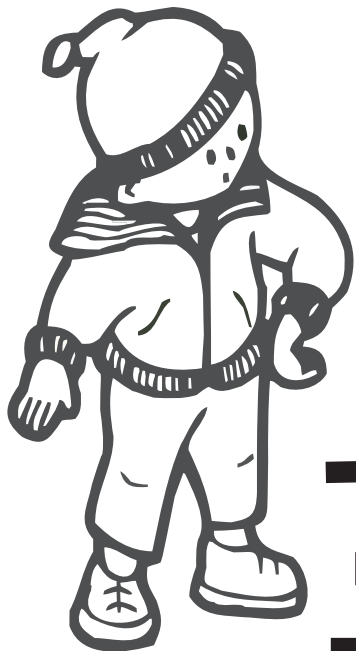

Nombre:



Tarea: Trazos verticales y horizontales
Técnica: Colorear con ceras duras

Fecha:

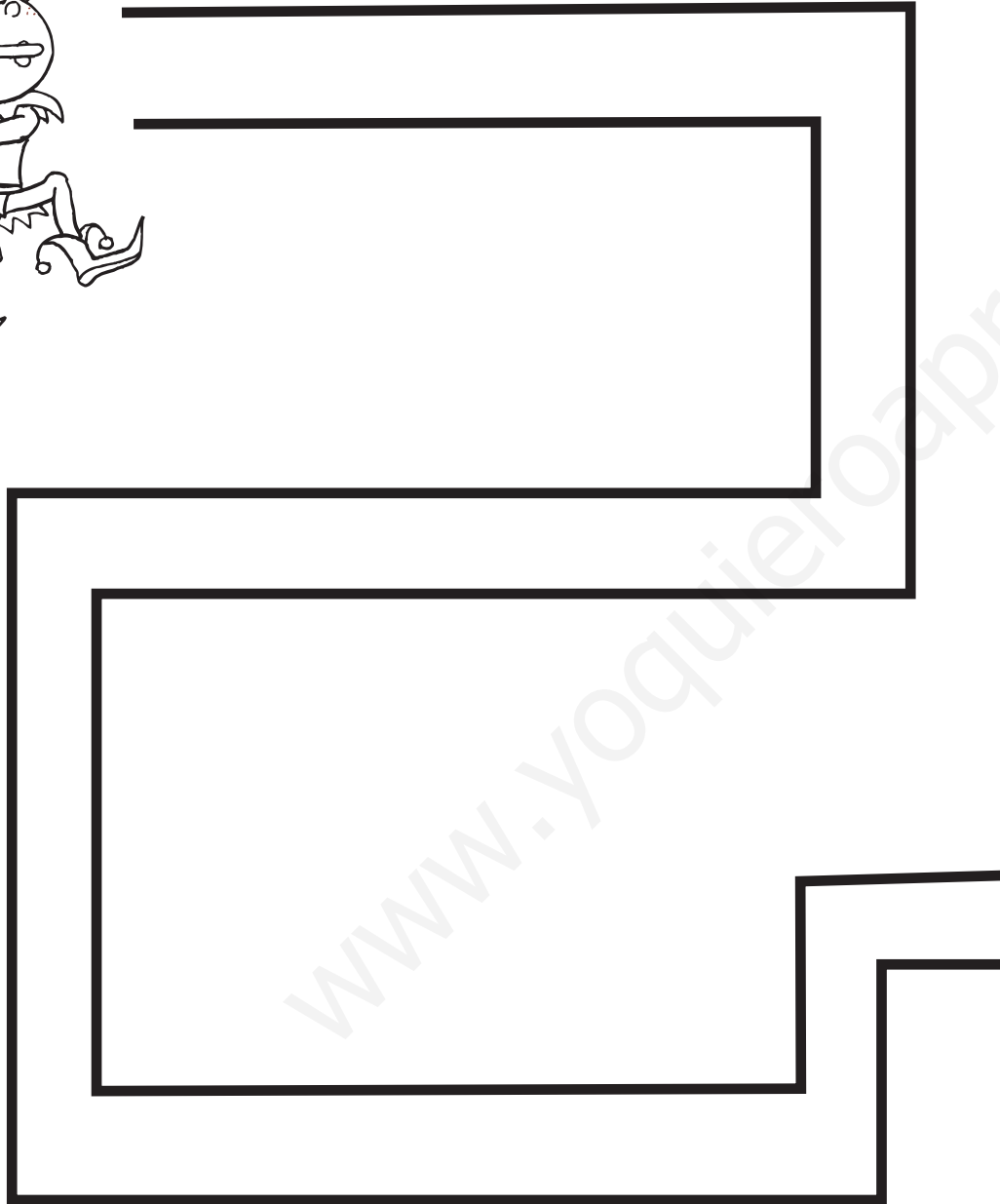
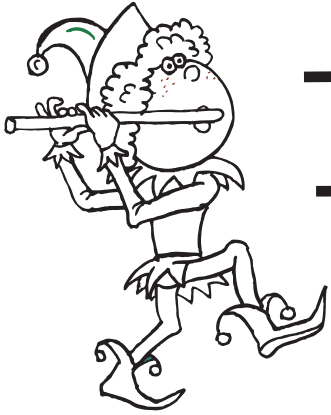

Nombre:



Tarea: Trazos verticales y horizontales
Técnica: Colorear con ceras duras.

Fecha:

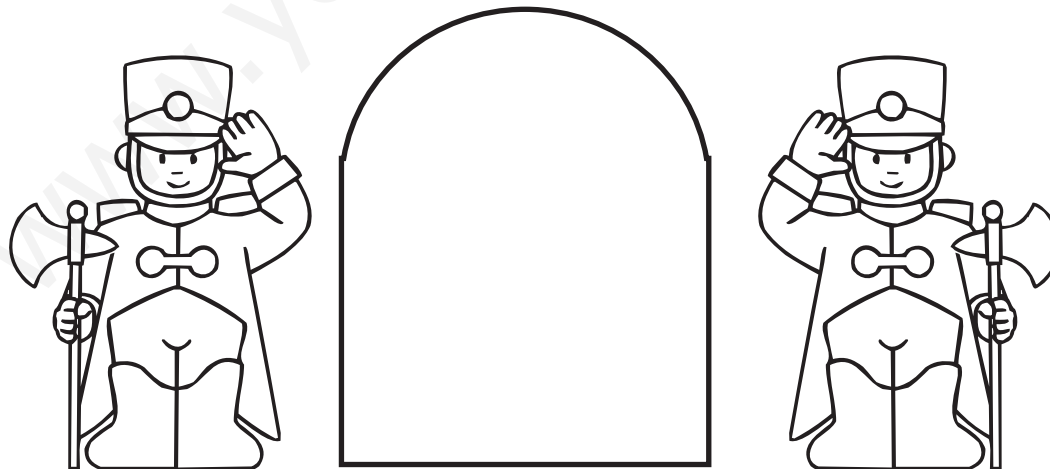
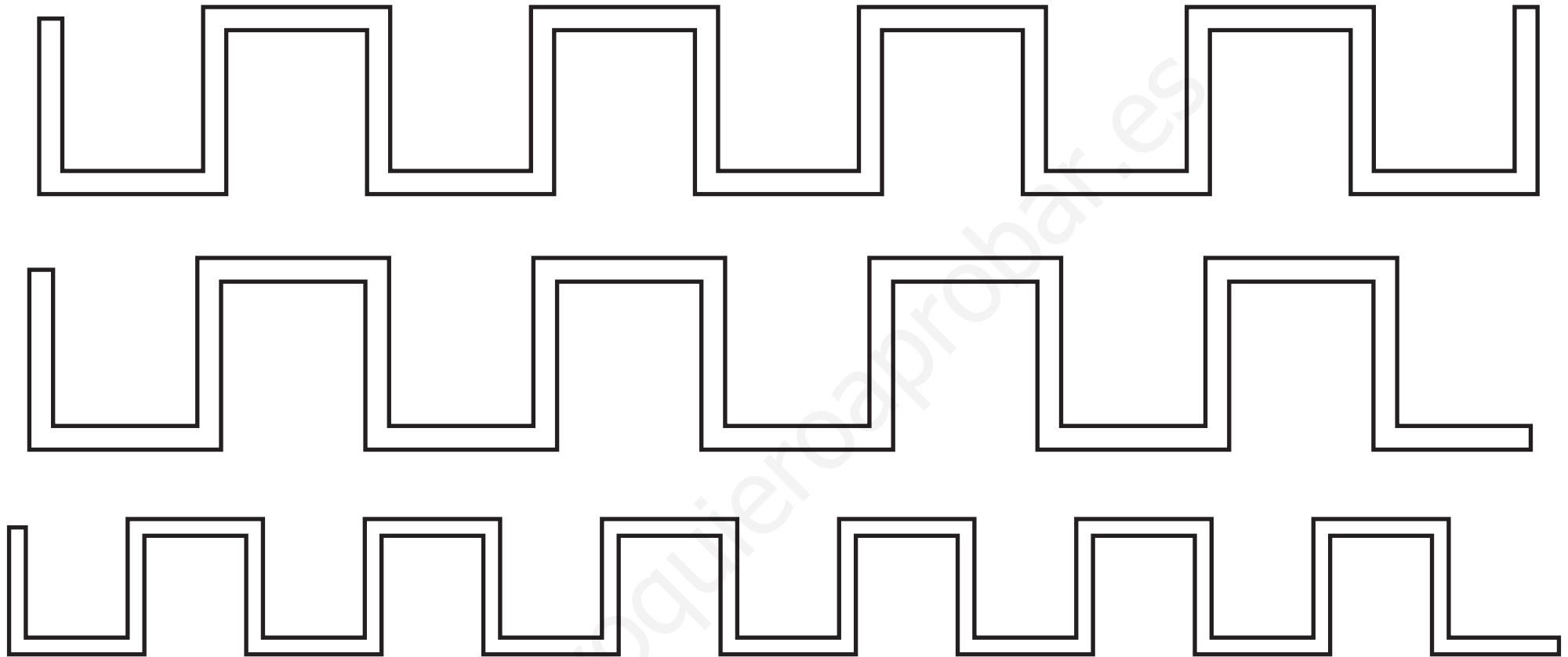

Nombre:



Tarea: Trazos verticales y horizontales
Técnica: Colorear con ceras duras

Fecha:





Nombre:



Tarea: Laberinto. Trazos oblicuos
Técnica: Colorear con ceras duras.

Fecha:

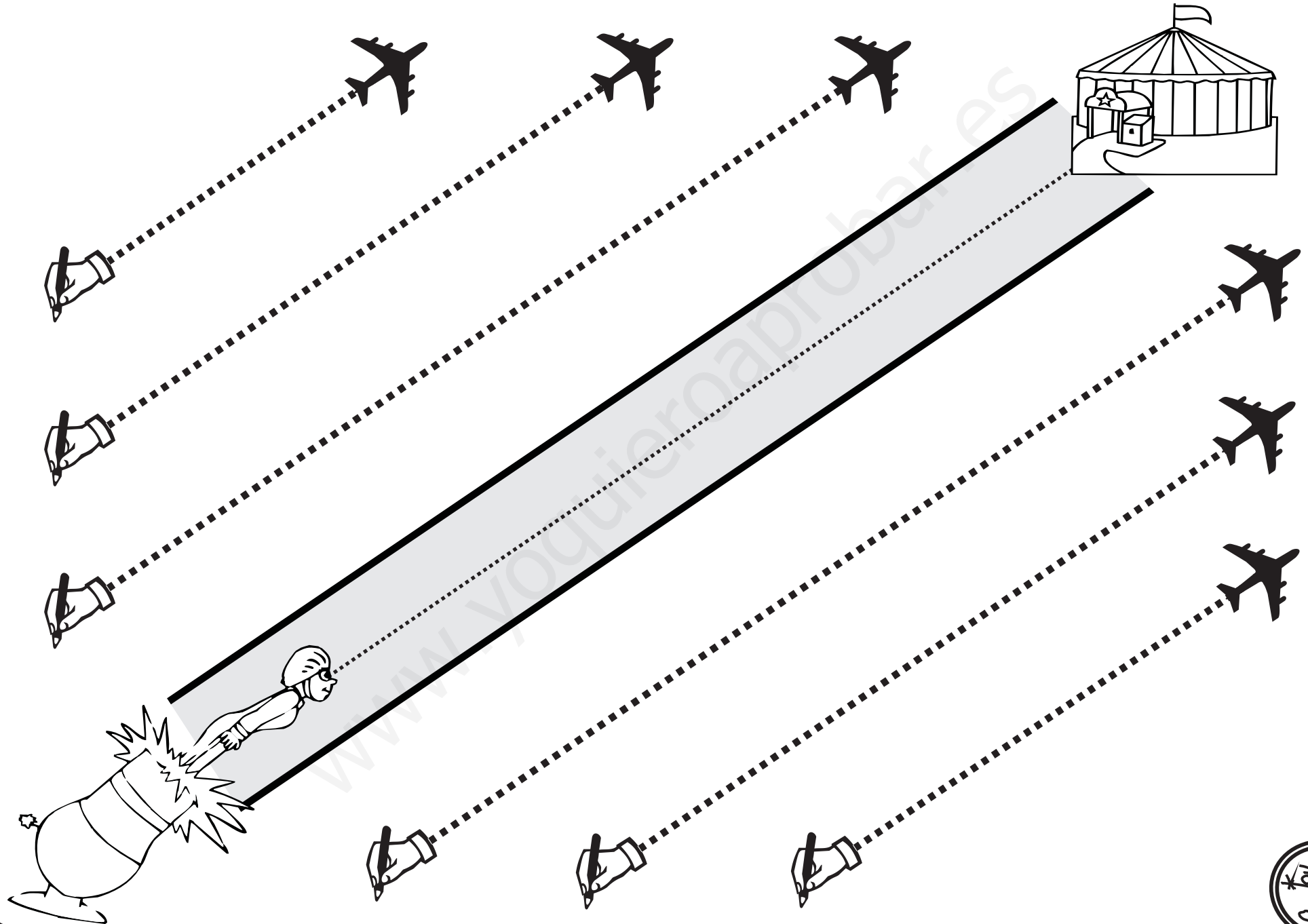

Nombre:



Tarea: Laberinto. Trazos curvos
Técnica: Colorear con ceras duras.

Fecha:



www.yoquieroaprobar.es



Nombre:



Tarea: Laberinto. Trazos curvos
Técnica: Colorear con ceras duras.

Fecha:

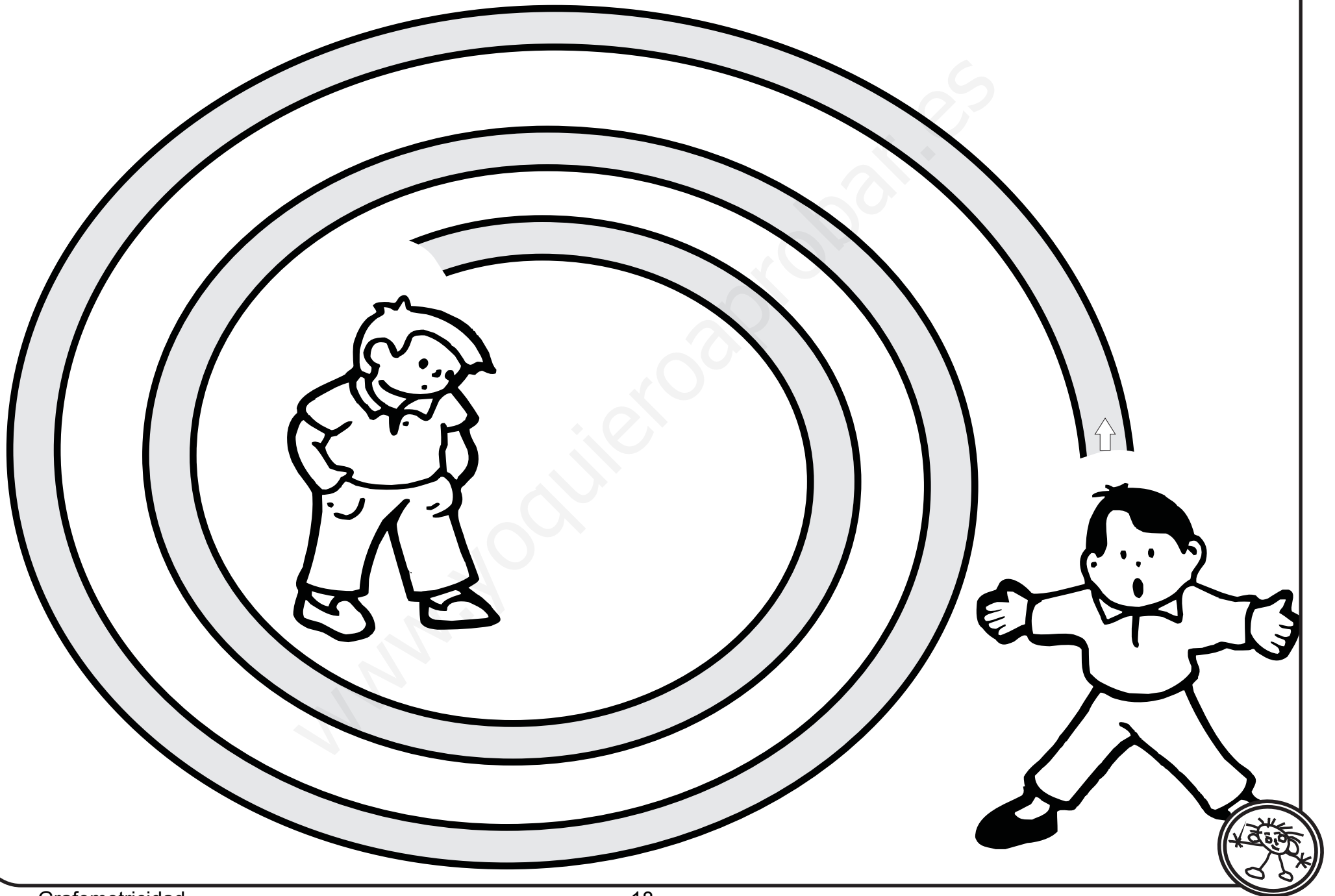

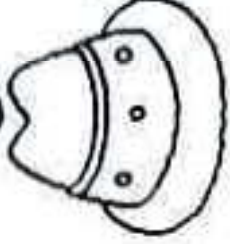
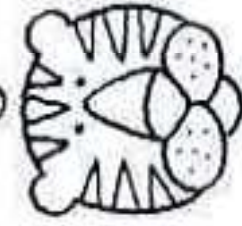
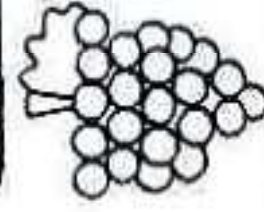
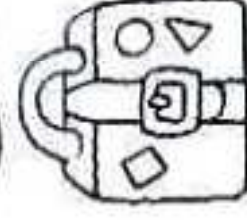
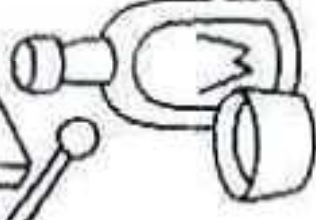
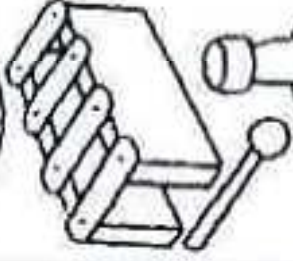
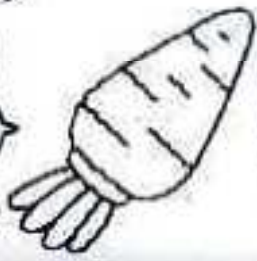
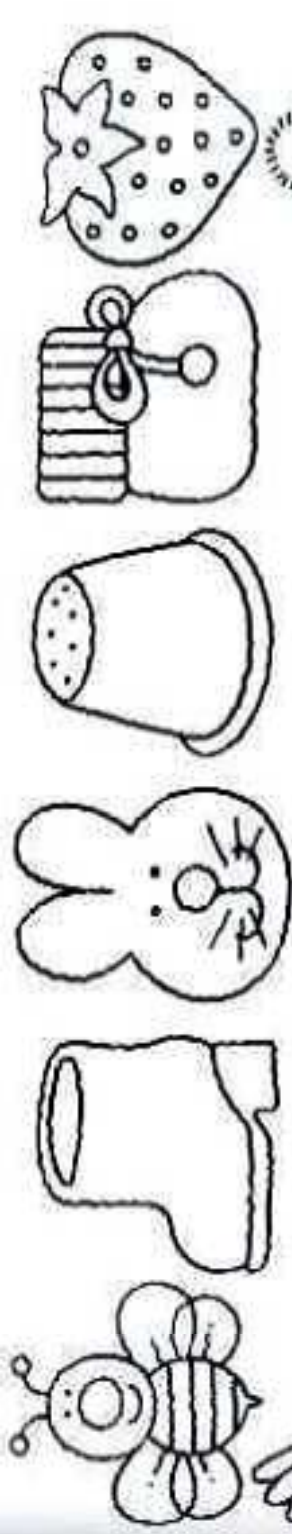

Este libro es de

www.yoquieroaprobar.es

(creada por I. M. Arce y J. García)

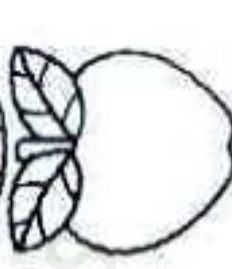
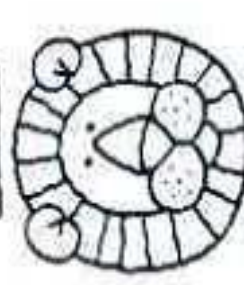
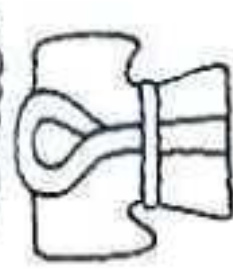
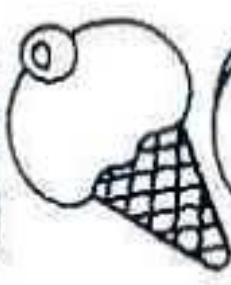

- DELINEA CON COLOR SIGUIENDO LA DIRECCIÓN INDICADA.
- COLOREA LA IMAGEN.

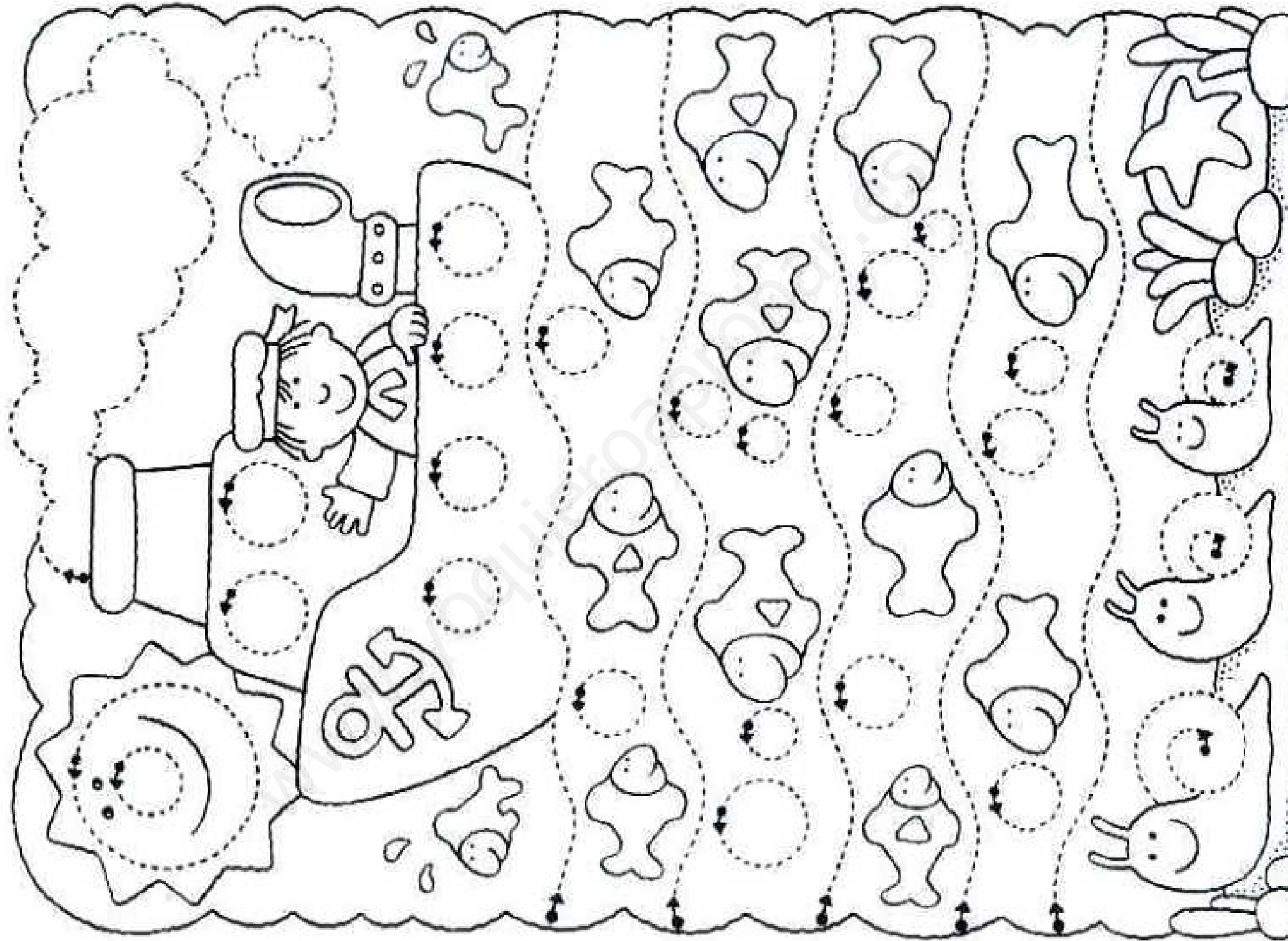

- DELINEA Y COMPLETA CADA RUEDA.
- COLOREA LOS JUGUETES QUE **NO** SON ANIMALES.

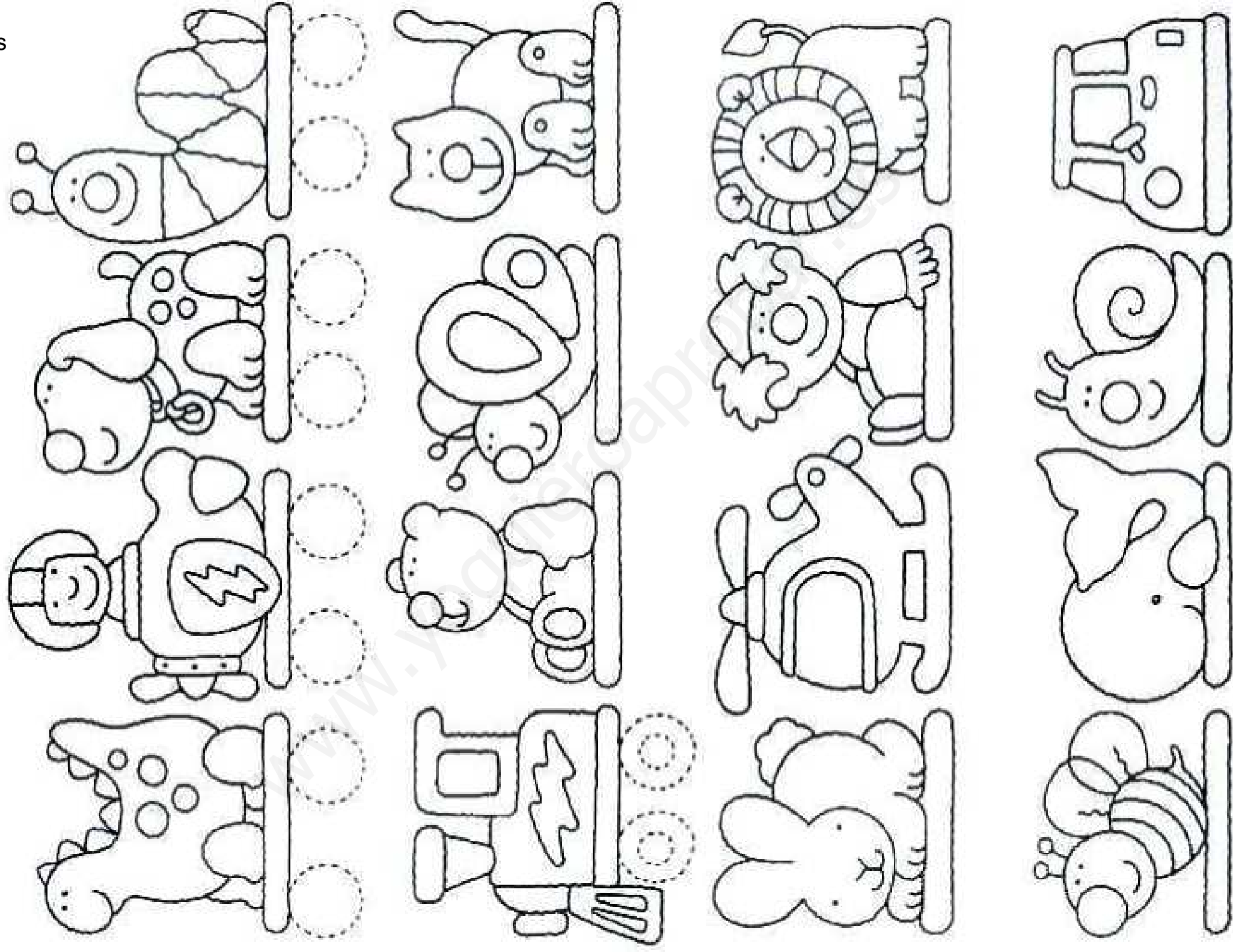

• DELINEA DE ADENTRO HACIA FUERA CADA ESPIRAL.
UTILIZA DIFERENTES COLORES.

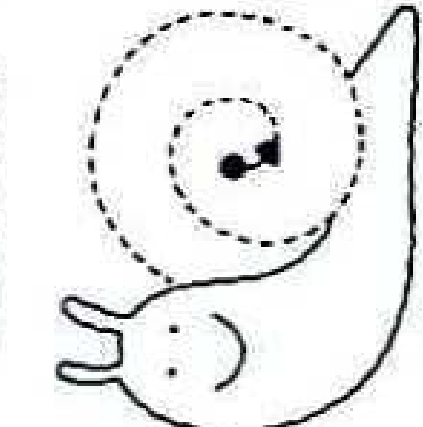
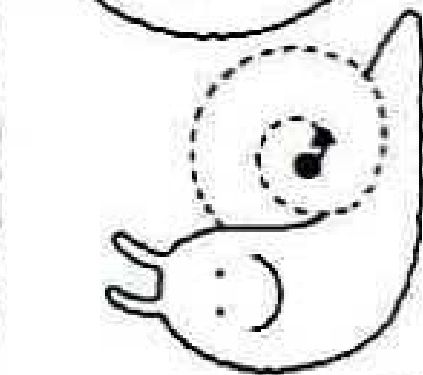
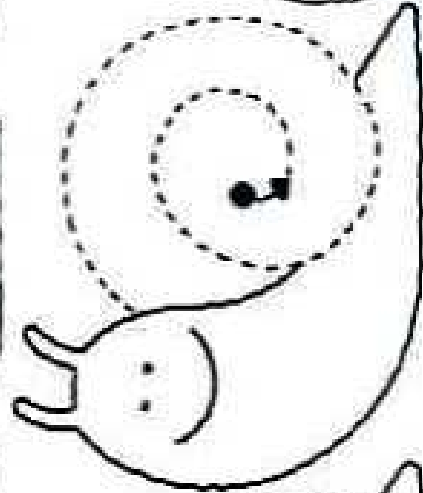
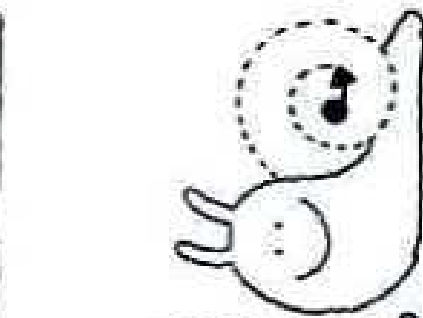
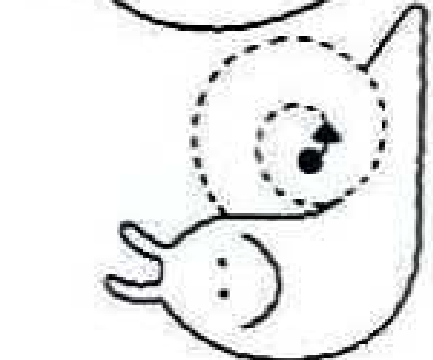
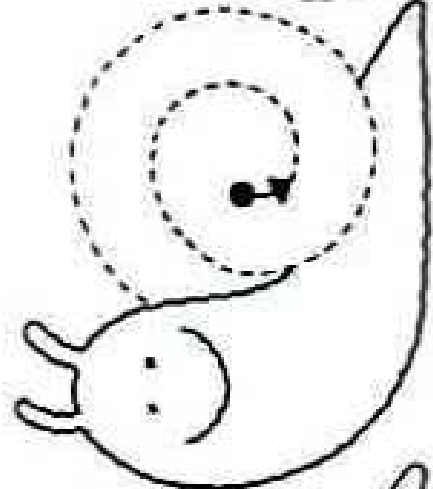
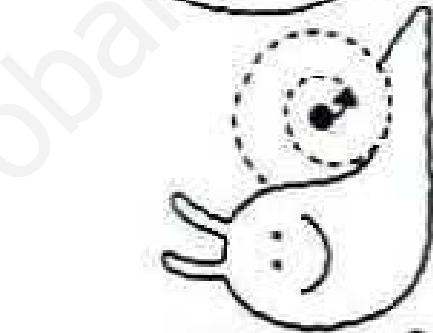
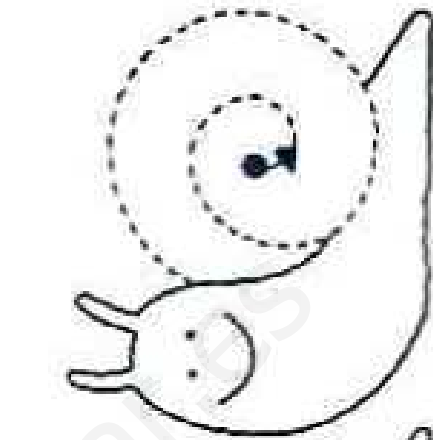
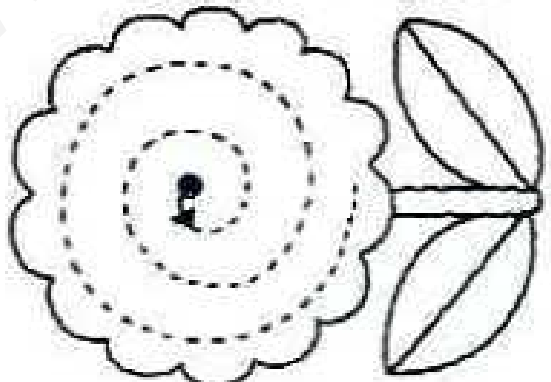
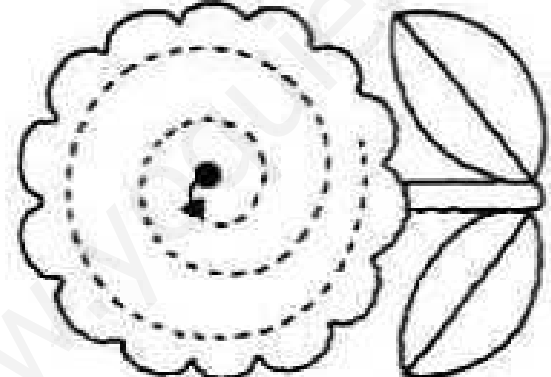
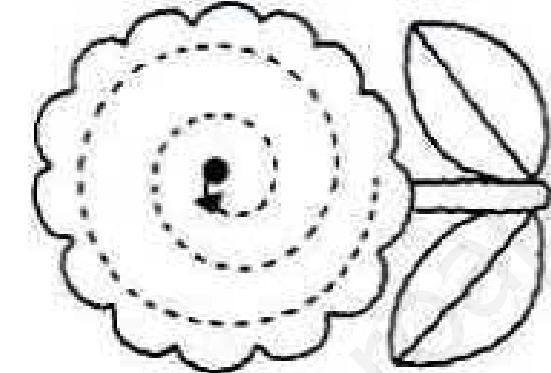
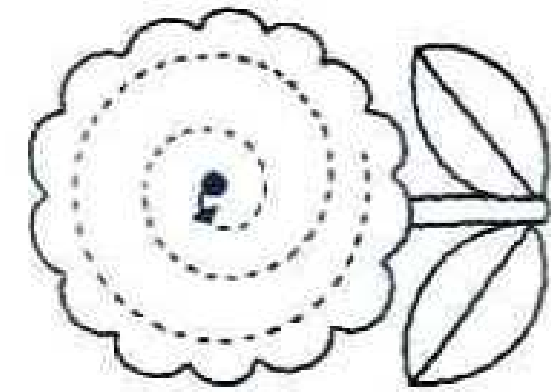
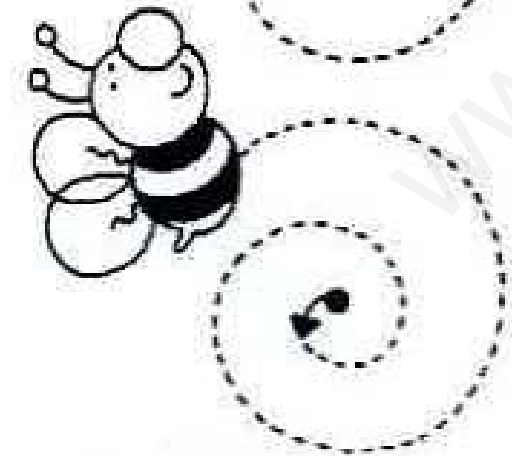
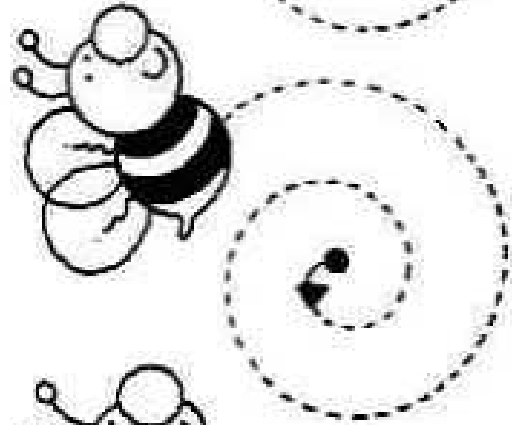
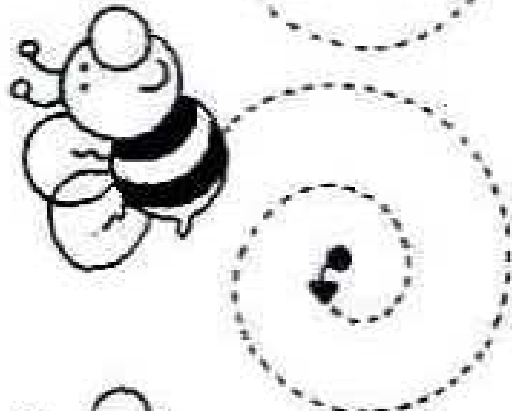

- RECORRE CON TU DEDO ÍNDICE EL CAMINO DE ESTOS INSECTOS.
- DELINEA Y COMPLETA CADA RECORRIDO.



www.yoquieroaprobar.es

- RECORRE CON TU DEDO ÍNDICE ESTAS GUARDAS.
- DELINEA CON UN COLOR DIFERENTE CADA GUARDA.
- COMPLETA LOS PIZARRONES COPIANDO LAS GUARDAS DE ARRIBA.

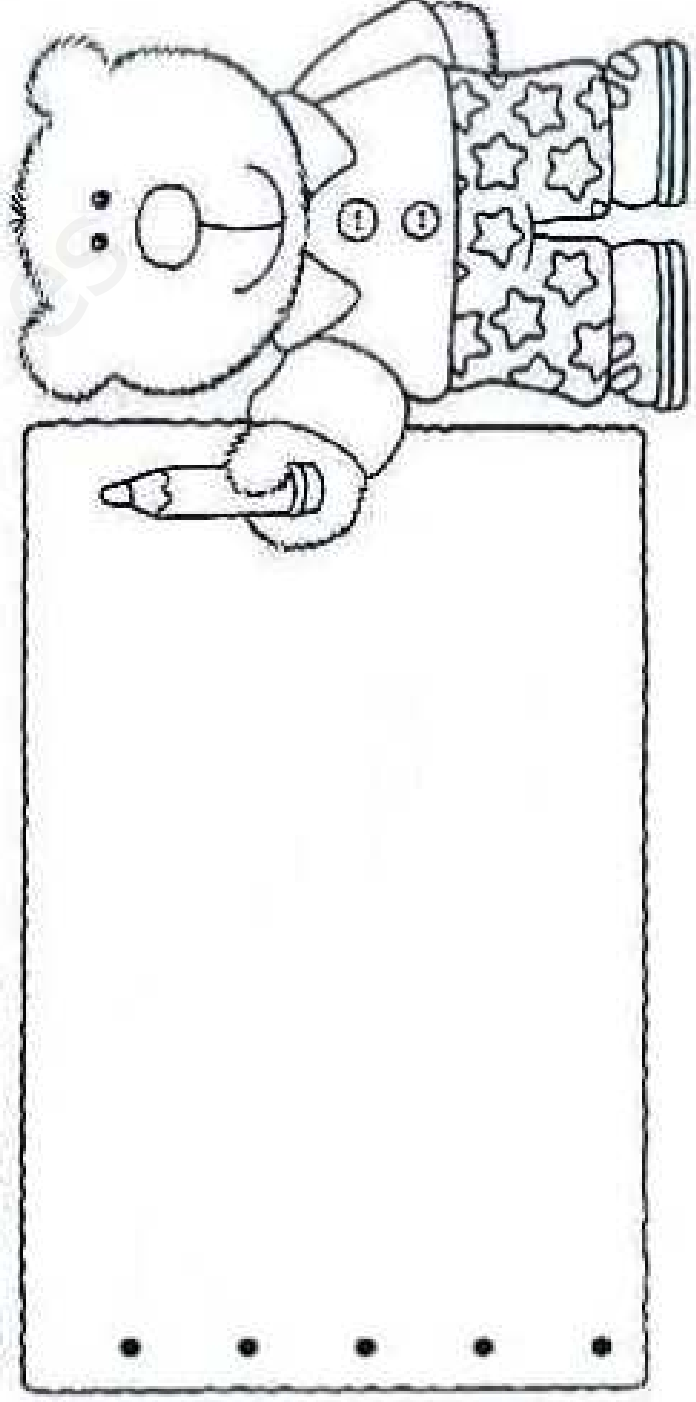
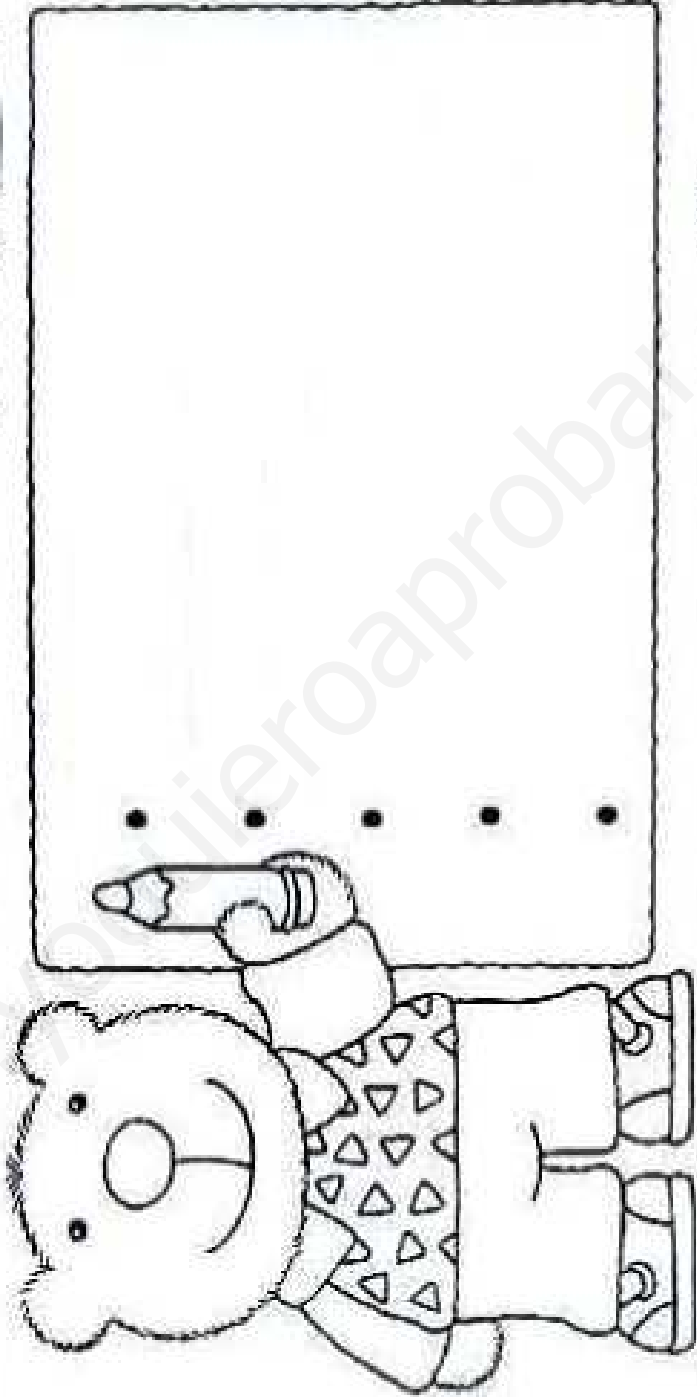
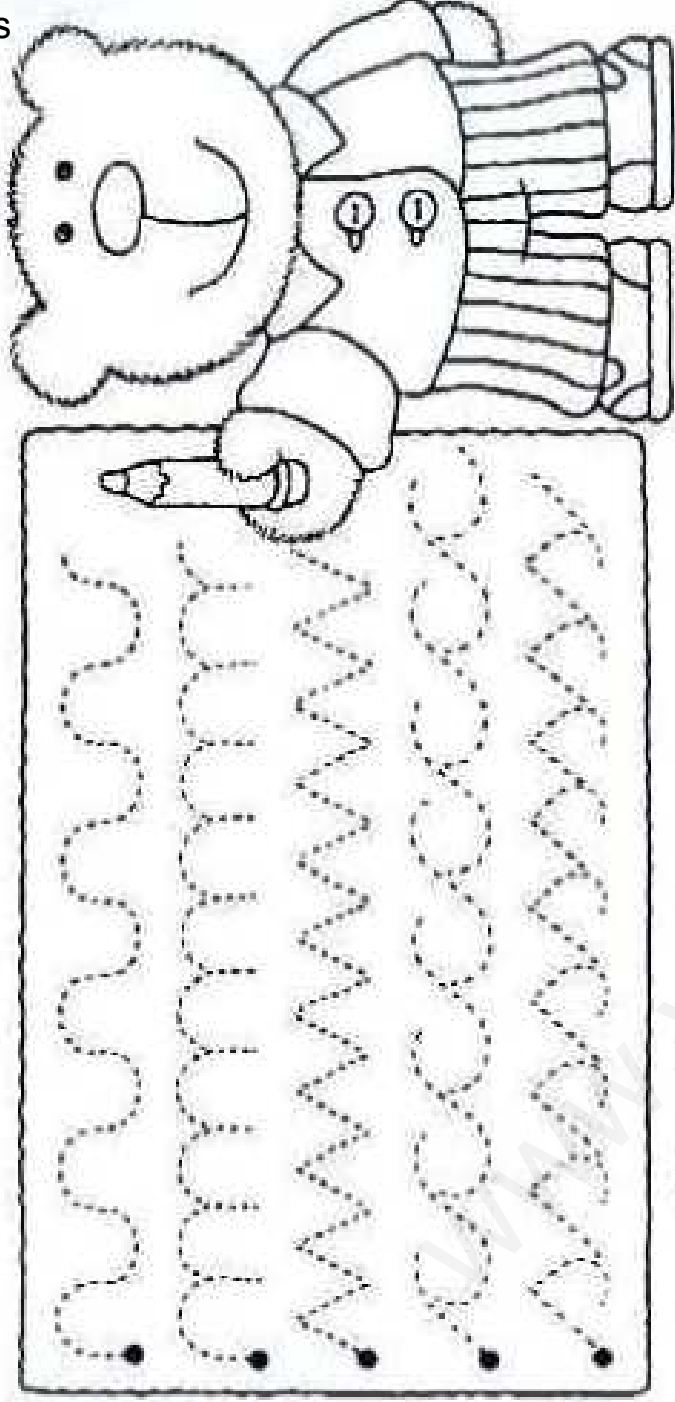

- DECORA CON GUARDAS LOS PÓNCOS Y LAS VINCHAS DE LOS INDIECITOS. UTILIZA DISTINTOS COLORES.
- COLÓREA EL INDIIO QUE MIRA HACIA LA DERECHA.

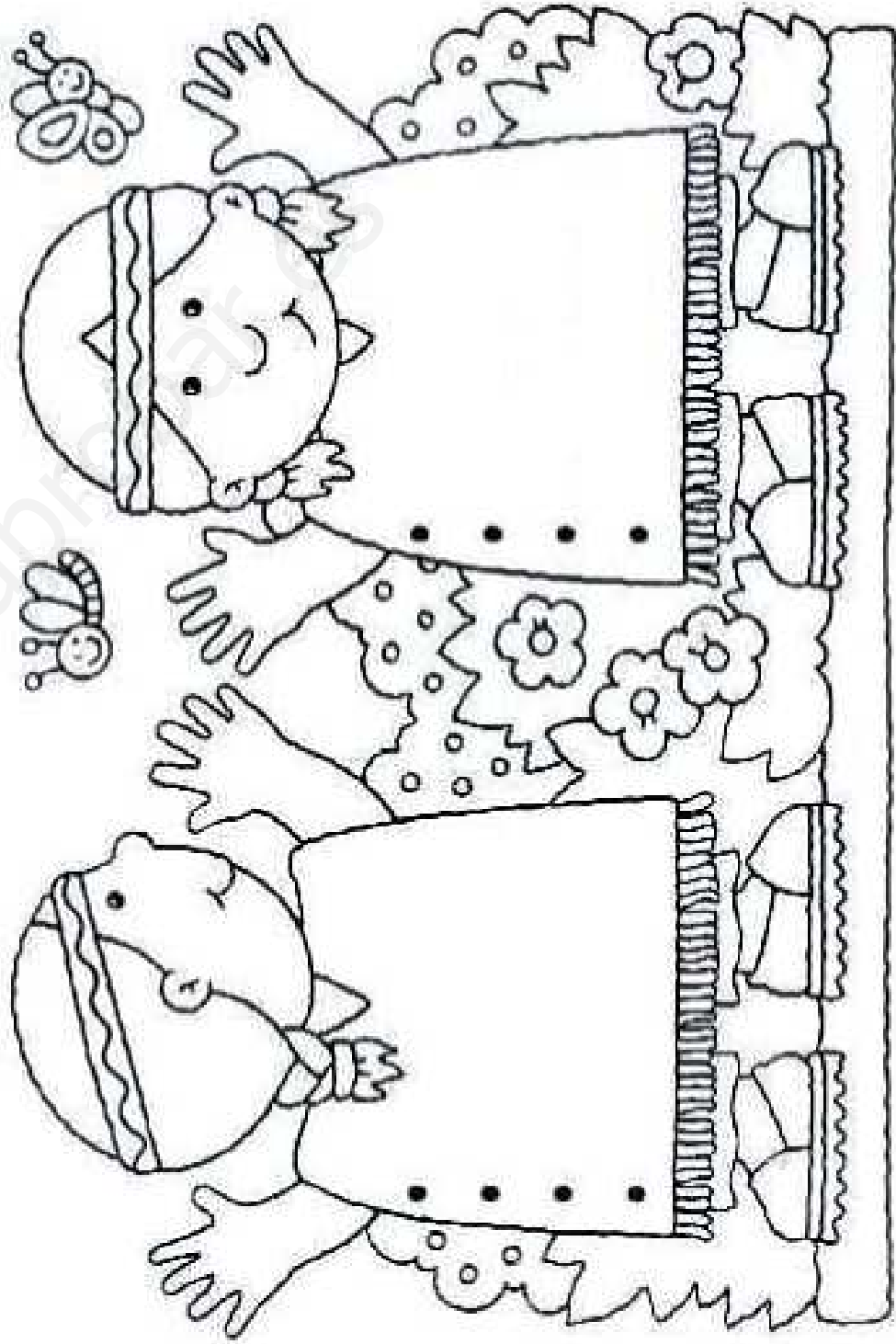
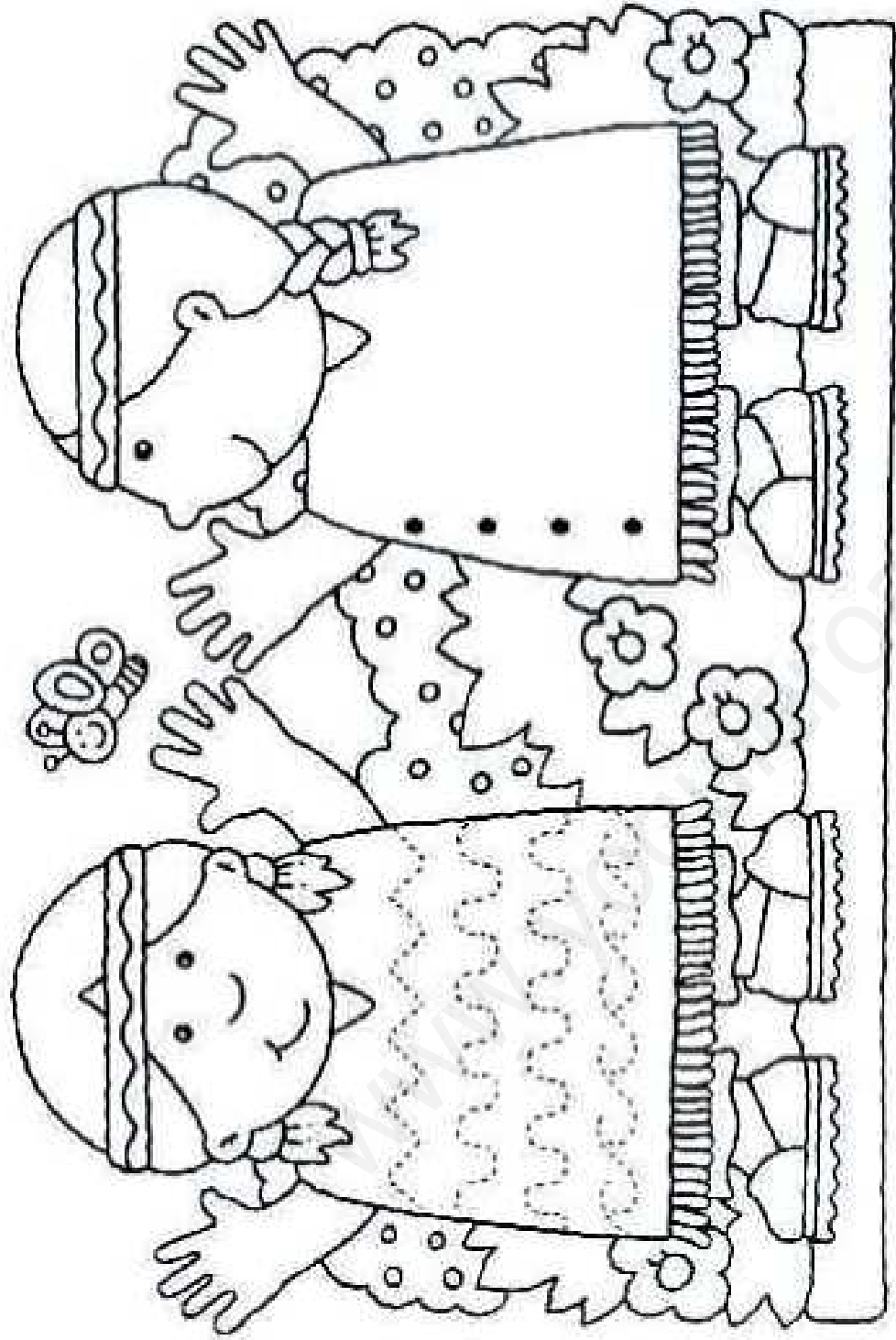

- DECORA LA ALFOMBRA MÁGICA CON GUARDAS COMO MÁS TE GUSTE
- COLOREA EL DIBUJO.

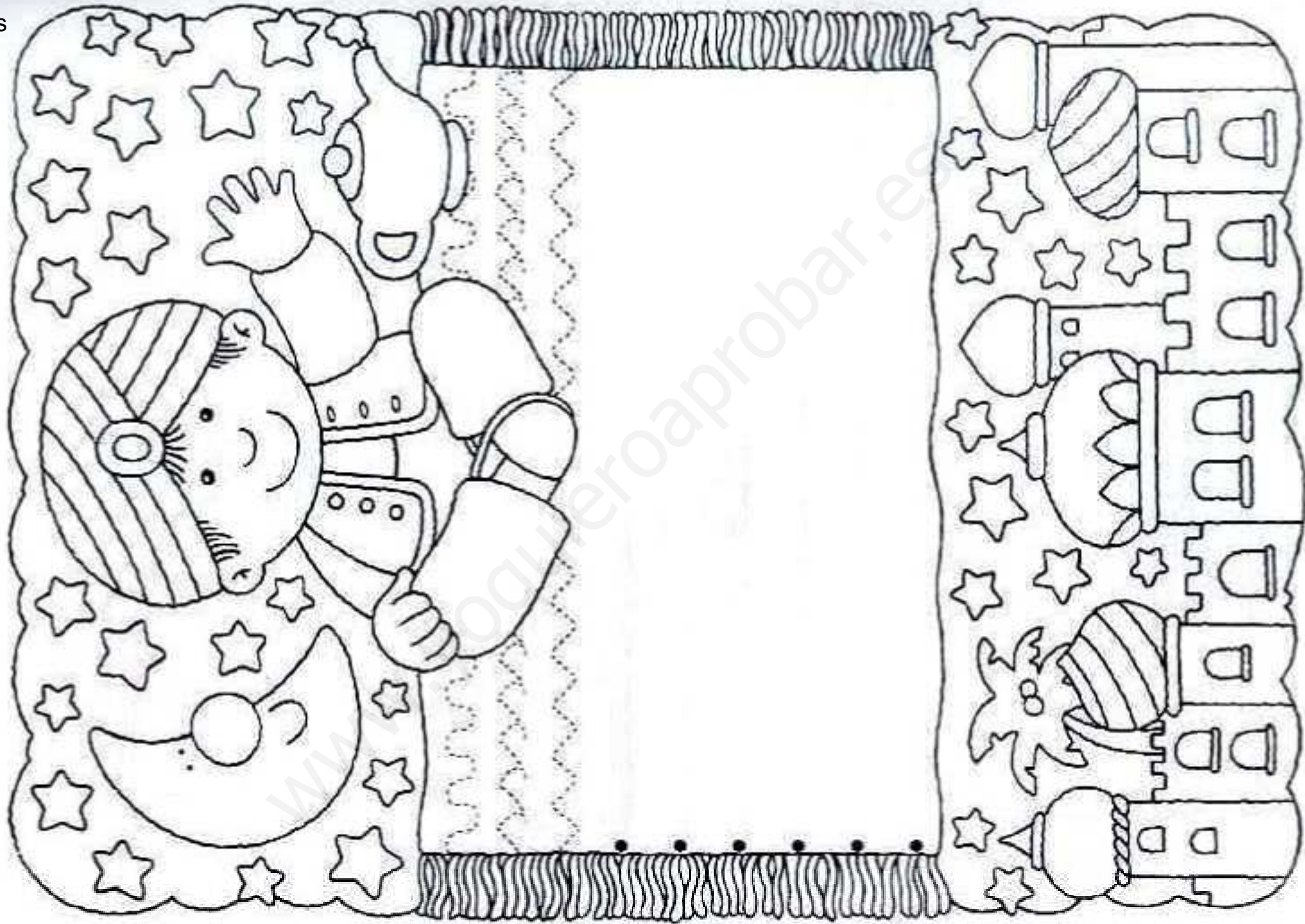

www.cooleroaprobar.es

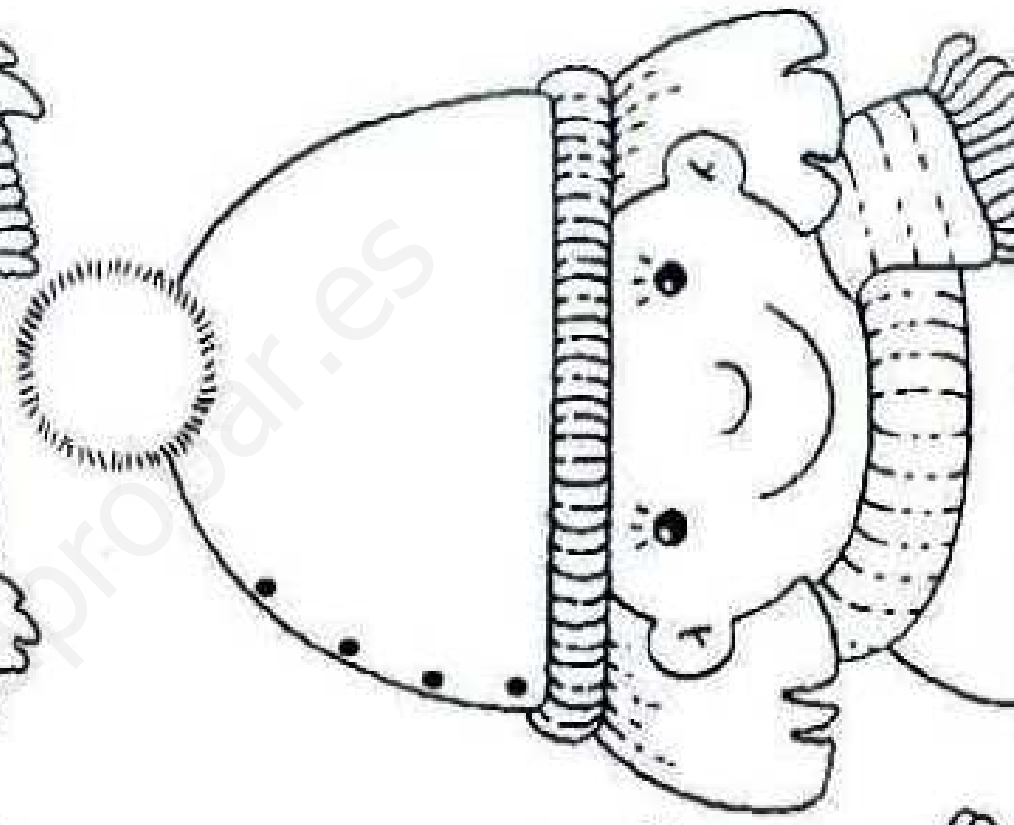
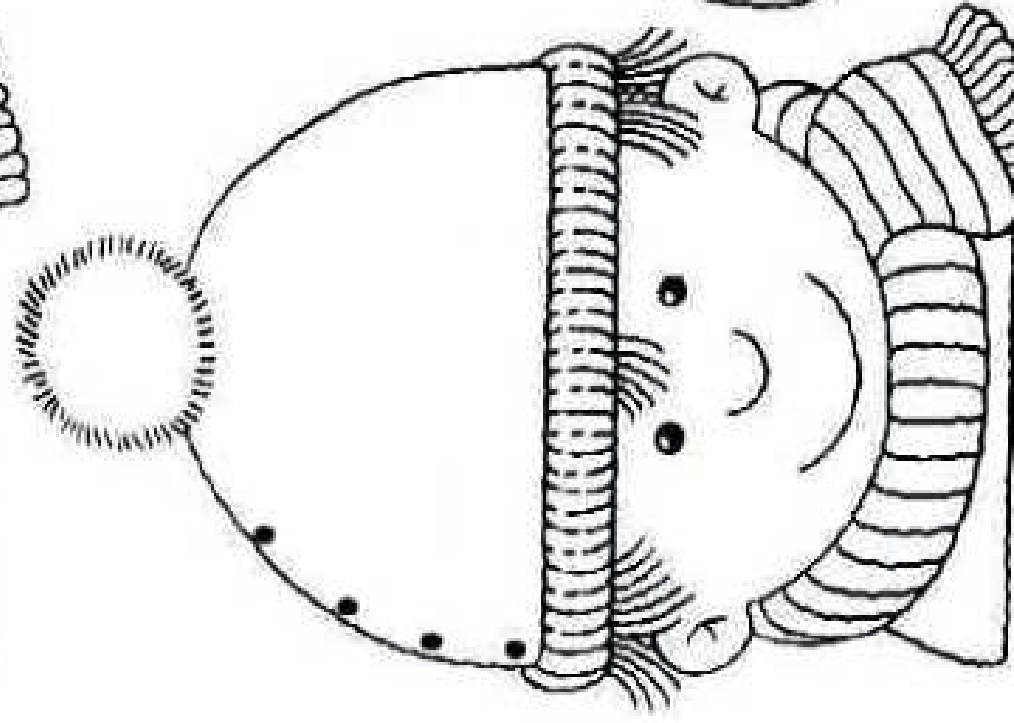
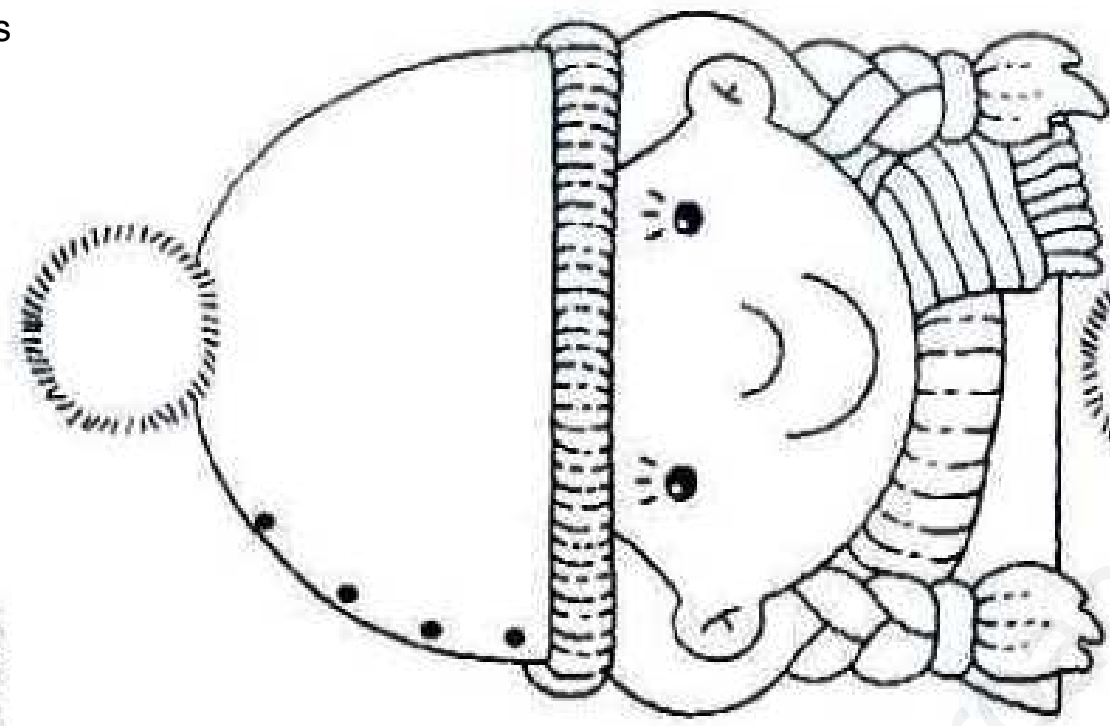
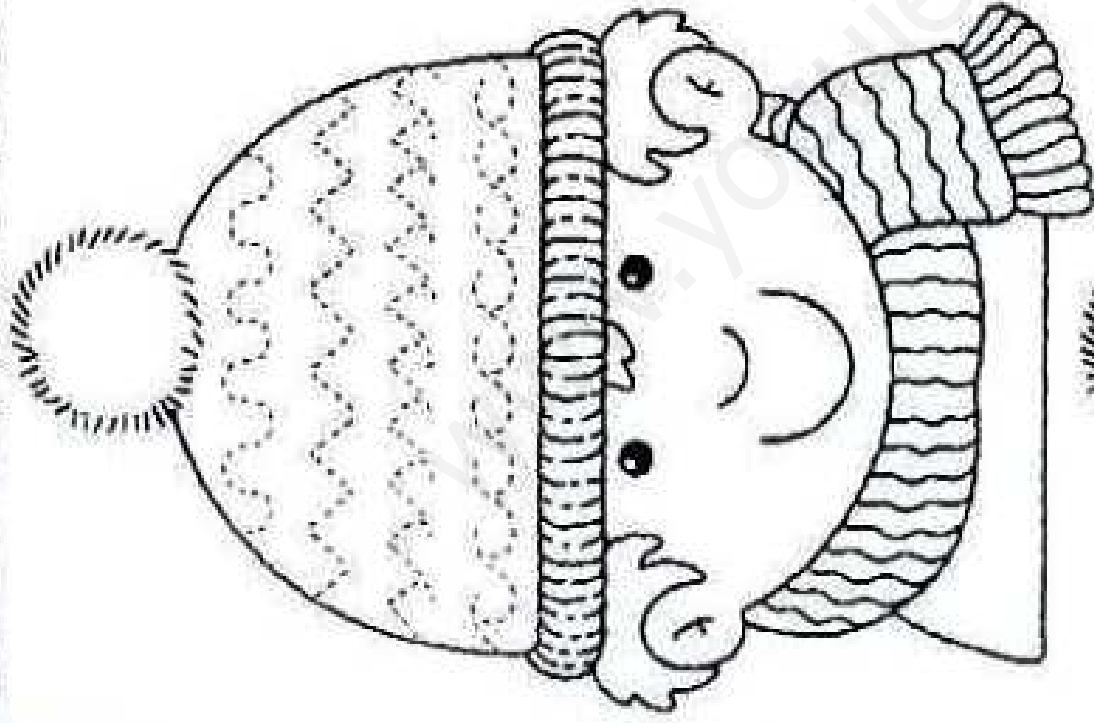

ESTE ES NUESTRO ABECEDARIO:
• DELINEA TODAS LAS LETRAS CON LINDOS COLORES.

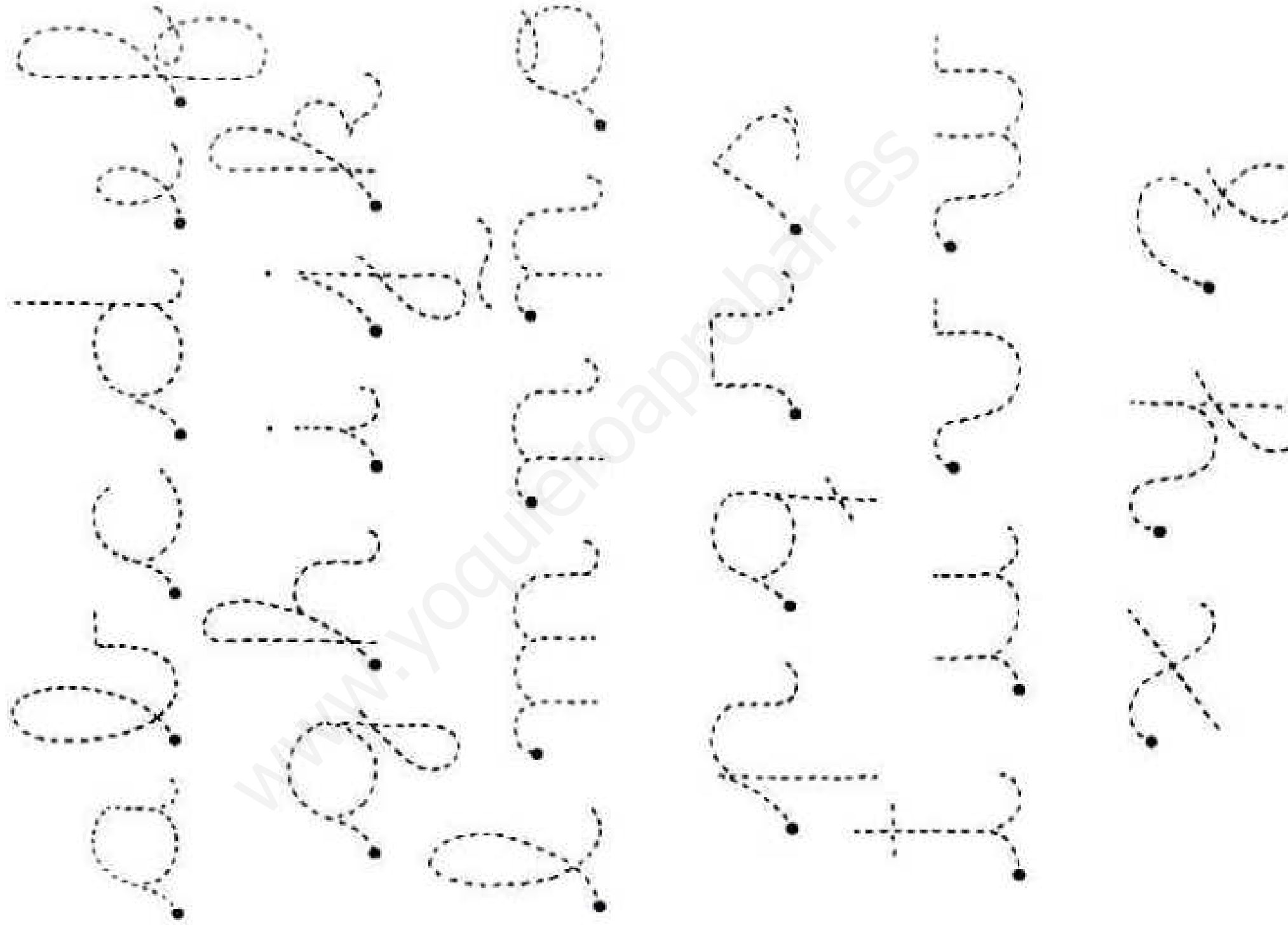

LETRAS ALTAS, LETRAS BAJAS, LETRAS QUE CUELGAN...

- DELINEA Y RODEA CON COLOR LAS LETRAS QUE **NO** SON ALTAS NI CUELGAN DEL RENGLÓN. OBSERVA LAS MANOS DEL TIGRE.

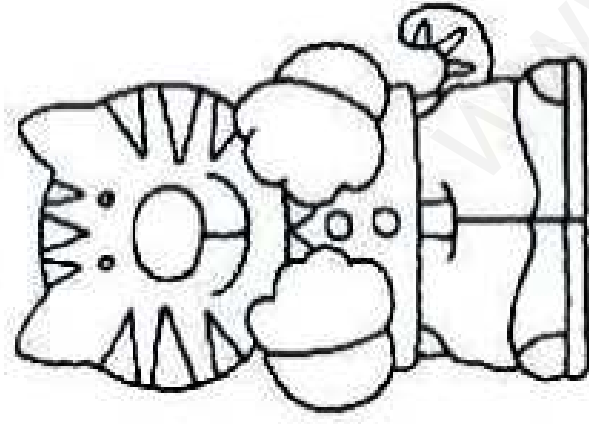

a b c d e f g h i j
k l m n ñ o p q
r s t u v w x y z

- DELINEA Y RODEA CON COLOR LAS LETRAS ALTAS. OBSERVA LA MANO DEL TIGRE.

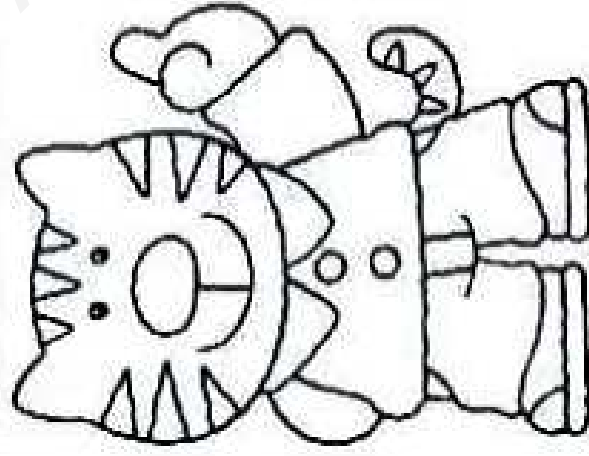

a b c d e f g h i j
k l m n ñ o p q
r s t u v w x y z

- DELINEA Y RODEA CON COLOR LAS LETRAS QUE CUELGAN DEL RENGLÓN. OBSERVA LA MANO DEL TIGRE.

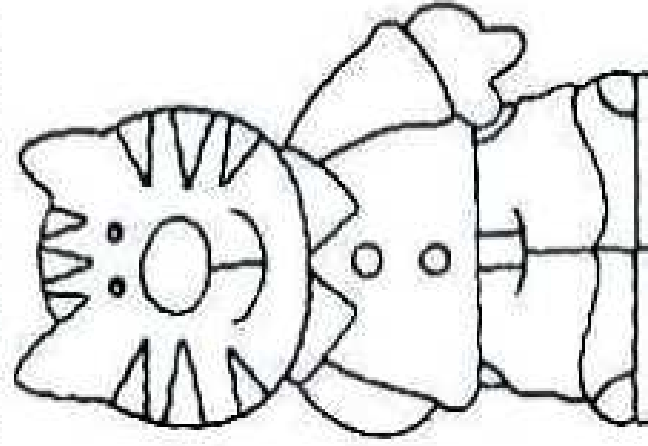

a b c d e f g h i j
k l m n ñ o p q
r s t u v w x y z

- RECORRE LAS LETRAS GRANDES CON TU DEDO ÍNDICE.
- DECÓRALAS COMO MÁS TE GUSTE.

a b c d e f g h i j k l m n ñ o p q r s t u v w x y z

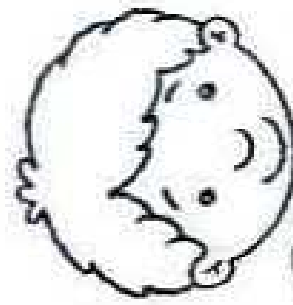
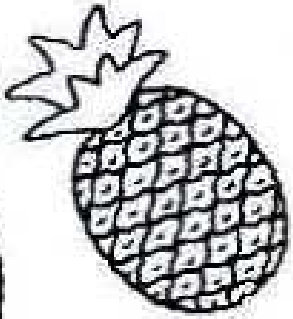
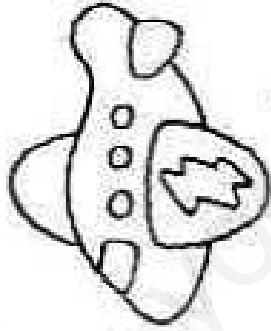
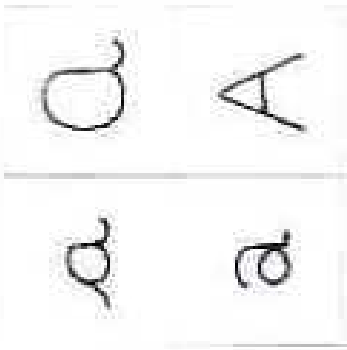
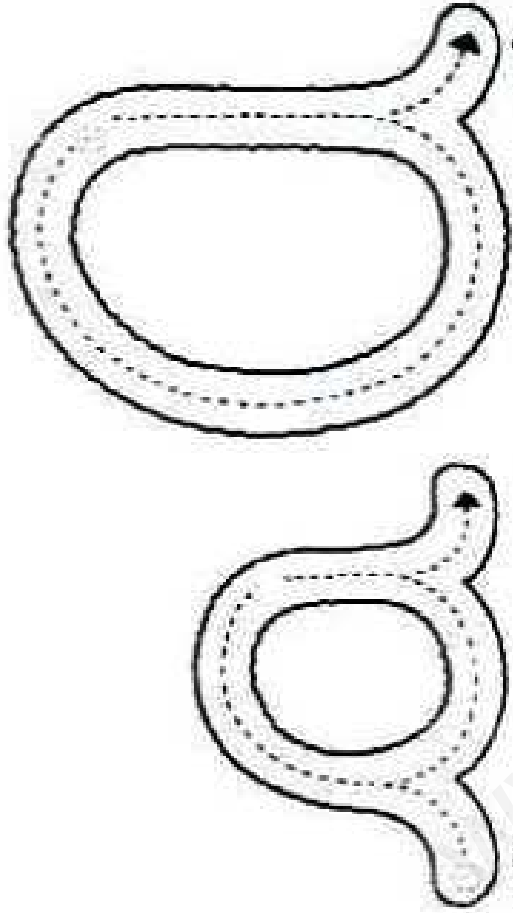

abeja avión amamá Andrés

- DELINEA Y COMPLETA CADA RENGLÓN.

a a a a a a a a a a

a

a

a

a

aa - aa

aaa - aaa



- DELINEA CON ROJITO TODAS LAS "A" DE LA FORMULA MAGICA.
- REPASA CON COLOR TODAS LAS VOCALES QUE SALEN DEL CALDERO.

- COLOREA LOS OBJETOS CUYOS NOMBRES COMIENZAN CON "A".
- ESCRIBE LA LETRA DEBAJO DE CADA UNO DE ELLOS.

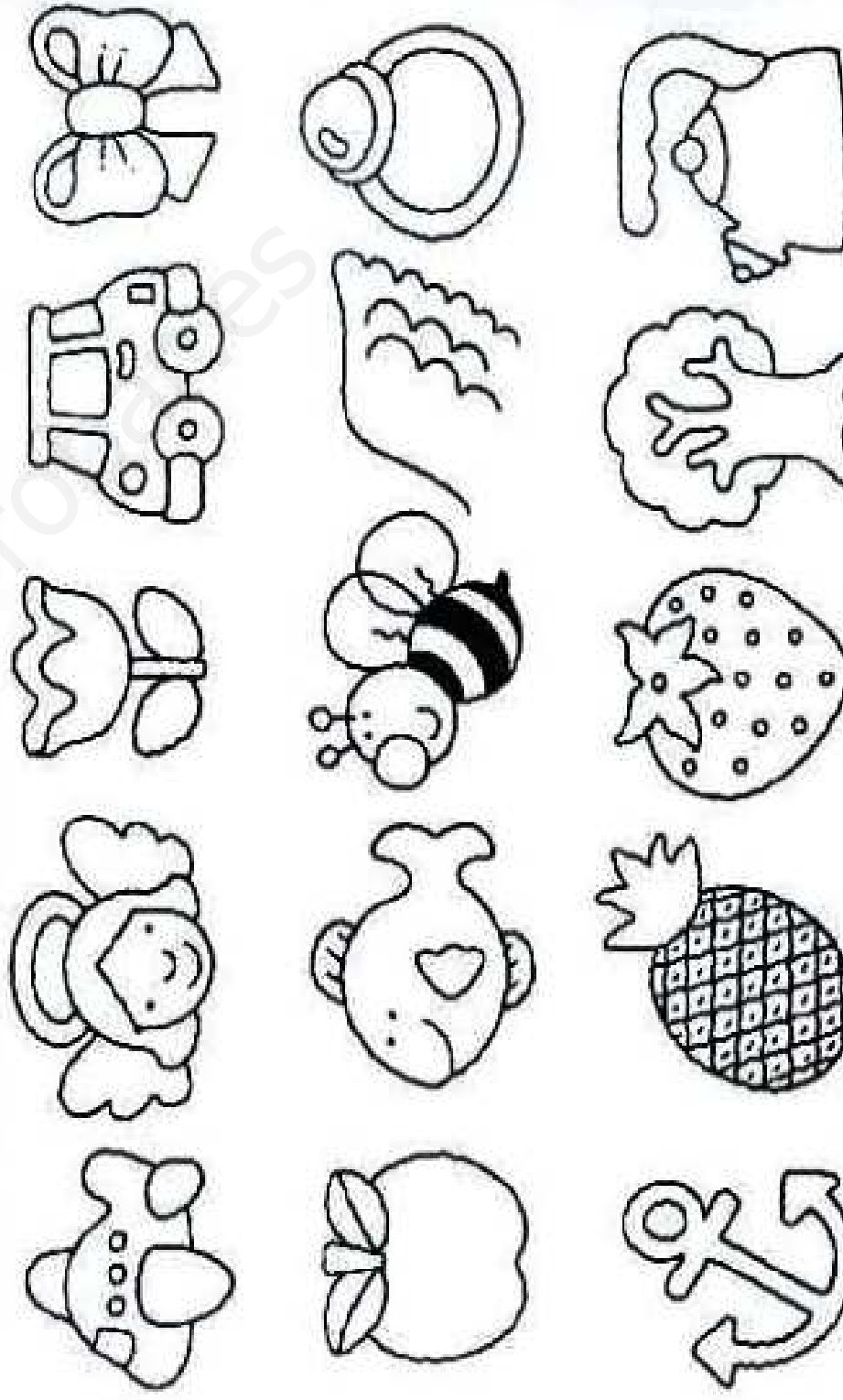

- ESCRIBE LA LETRA "E" EN CURSIVA DENTRO DE CADA ESTRELLA.
- MARCA CON UNA CRUZ LA OREJA DERECHA Y LA PATA IZQUIERDA DEL ELEFANTE.

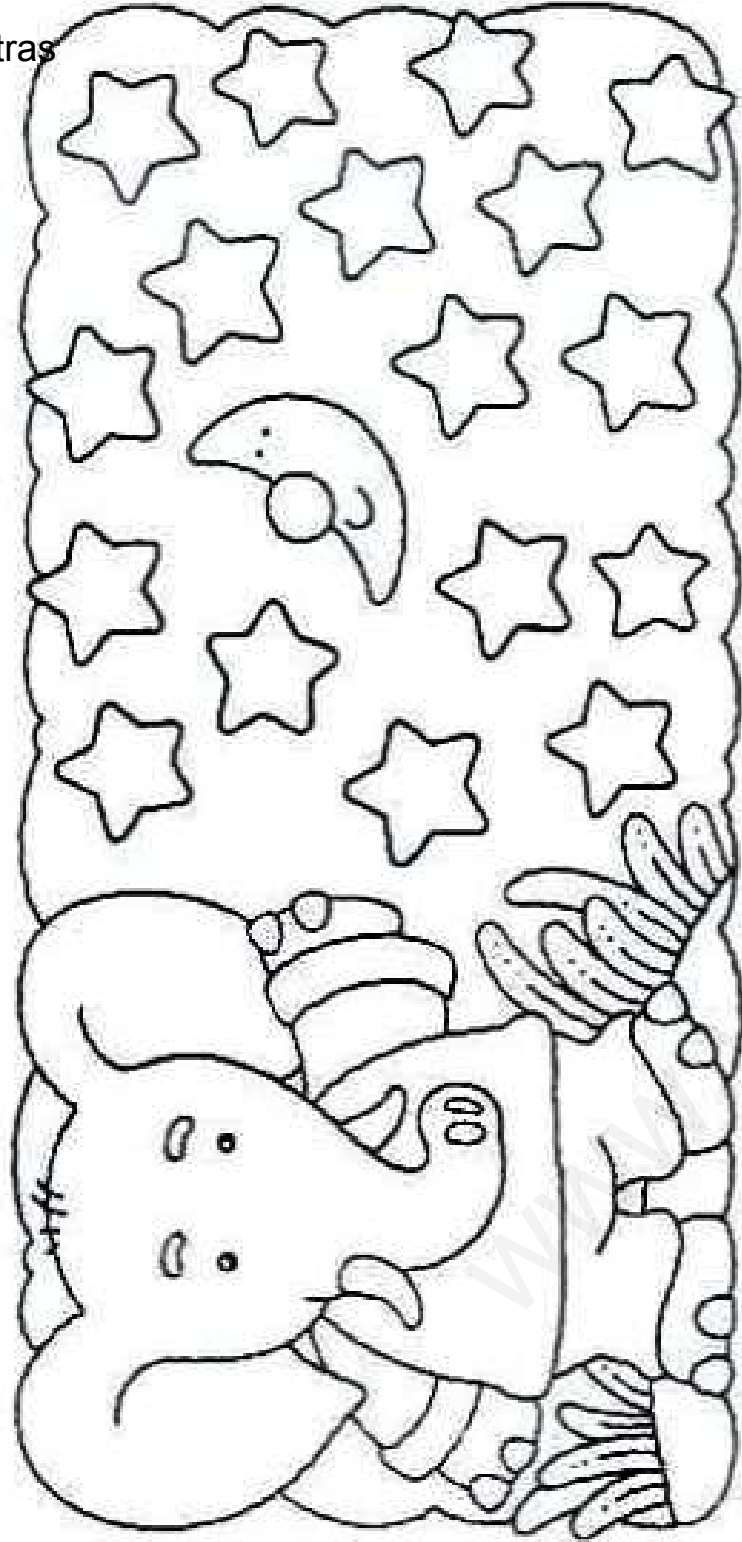

- DELINEA EL CAMINO DE ERNESTO EL ESCARABAJÓ.



- COMPLETA CON COLOR ROJO LAS LETRAS QUE FALTAN.
- DELINEA CADA PALABRA.

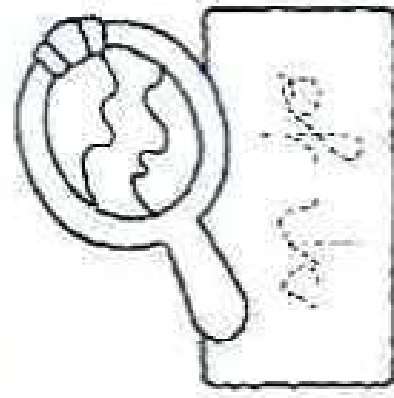
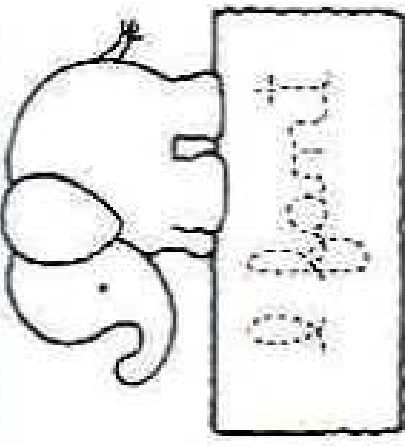
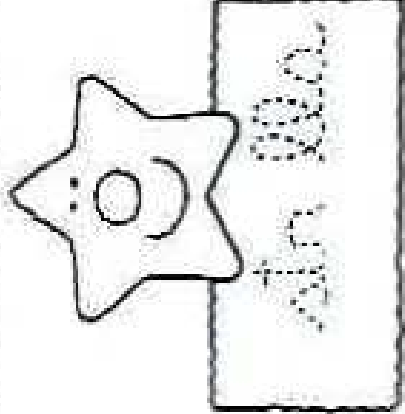
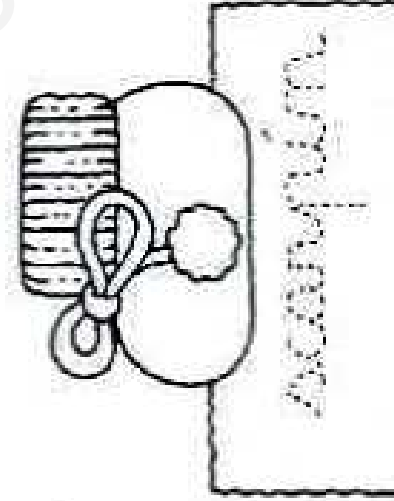
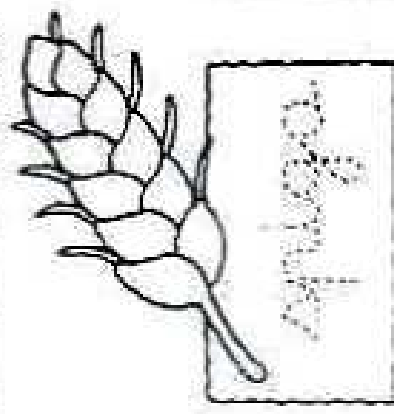

- RECORRE LAS LETRAS GRANDES CON TU DEDO ÍNDICE.
- DECÓRALAS CON PAPELITOS TROZADOS.

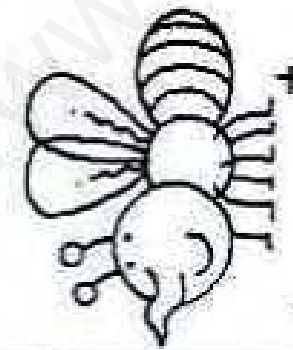
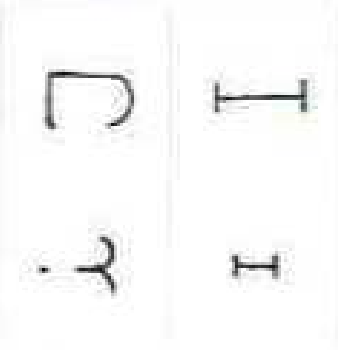
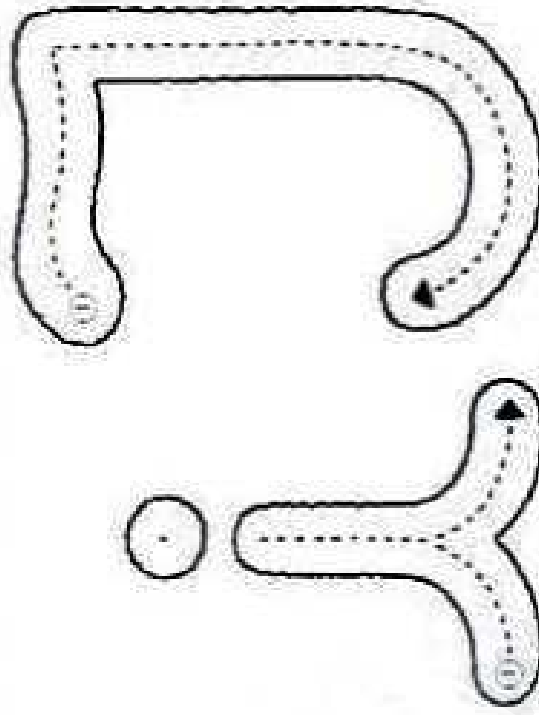

insectos imán

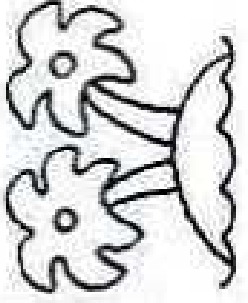

isla



Ignacio

- DELINEA Y COMPLETA CADA RENGLÓN.



i

i

i

ia-ia

ie-ie

iei-iei



- COLOREA DE ROJO LAS MANZANAS QUE CONTIENEN LA LETRA "I".
- MARCA CON UNA CRUZ EL PAJARITO Y EL GUSANO QUE ESTAN A LA IZQUIERDA DEL ÁRBOL.

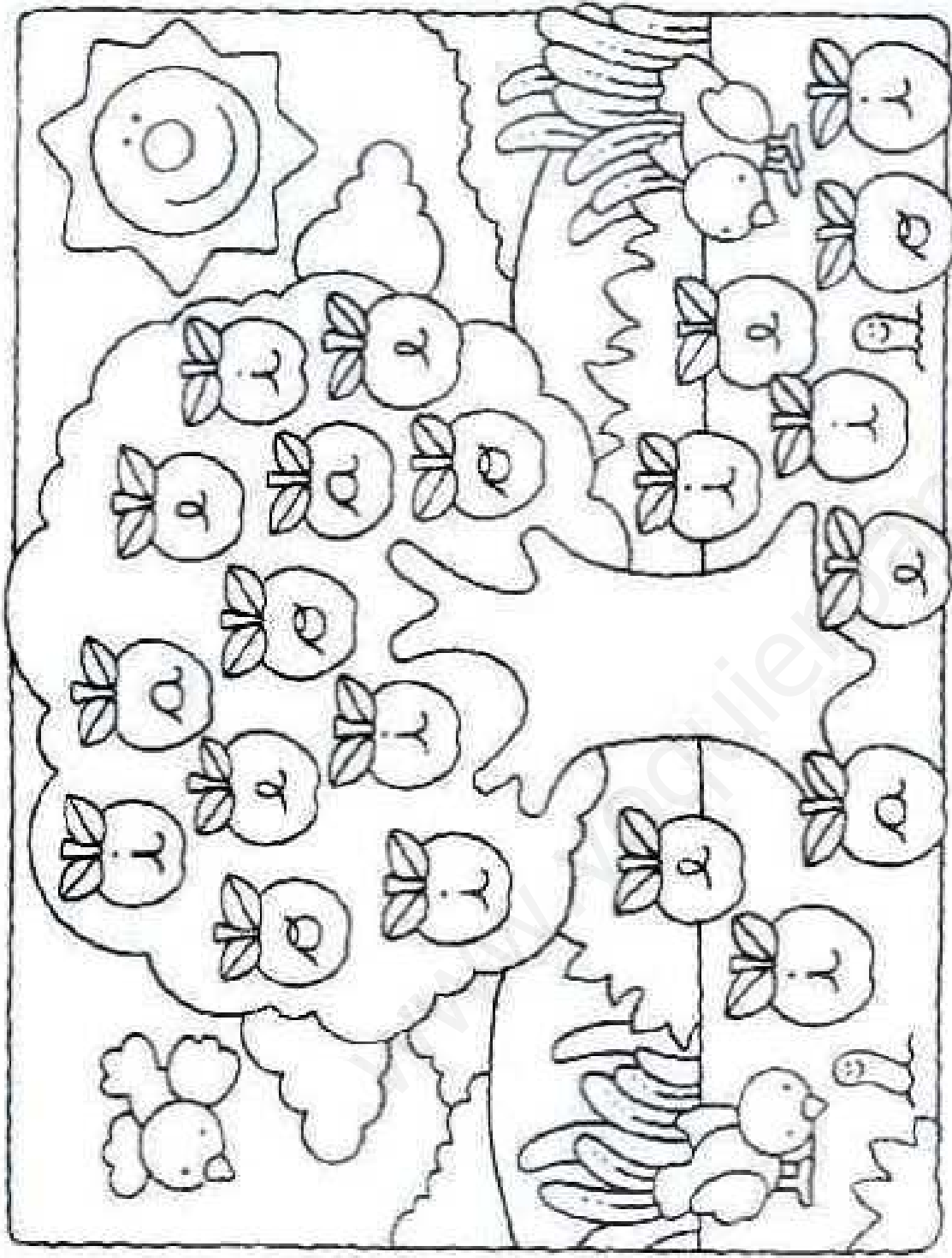

- DELINEA CON LAPIZ DE CÓLOR EL RECORRIDO DE LOS PAJARITOS.

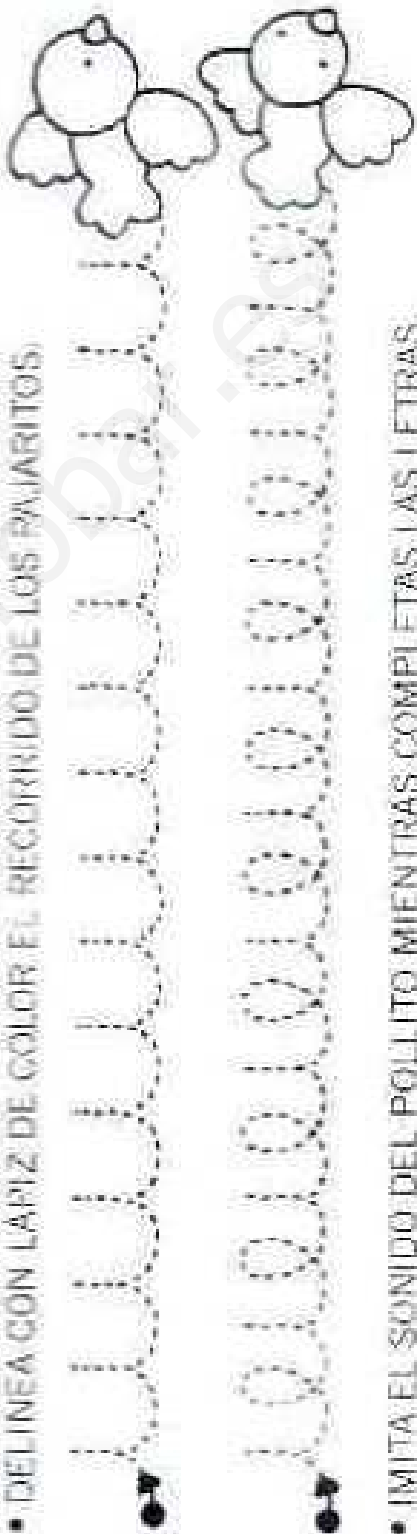

- IMITA EL SONIDO DEL POLLITO MIENTRAS COMPLETAS LAS LETRAS.

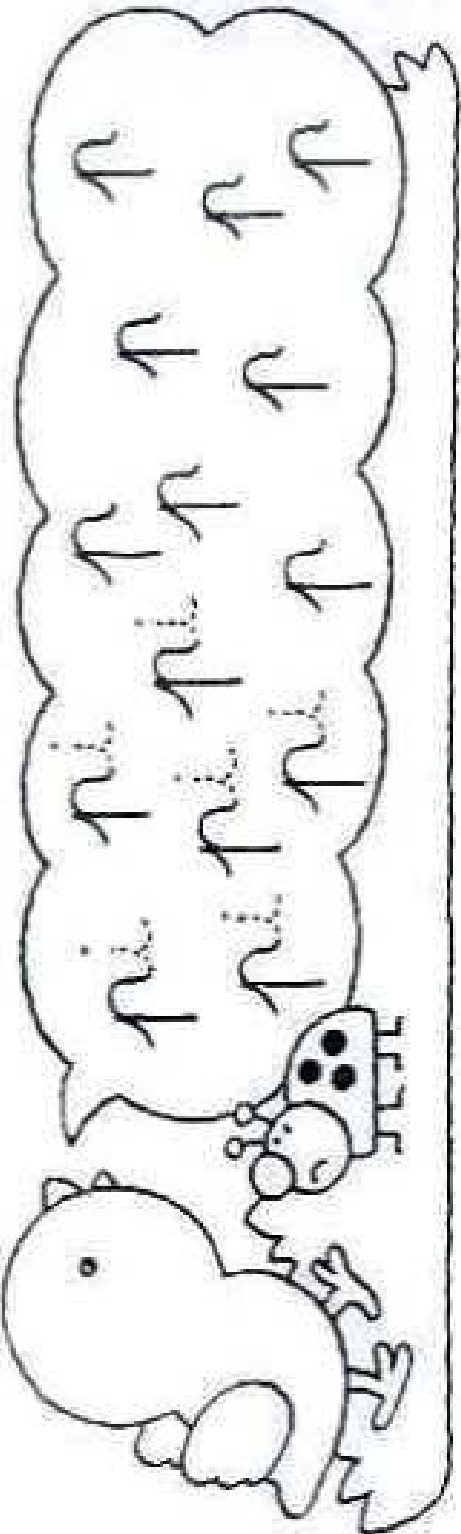

- RECORRE LAS LETRAS GRANDES CON TU DEDO ÍNDICE.
- DECÓRALAS CON PAPELITOS CORTADOS CON PUNZÓN.

a b c d e f g h i j k l m n ñ o p q r s t u v w x y z

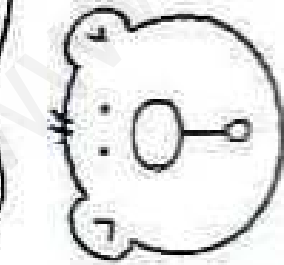
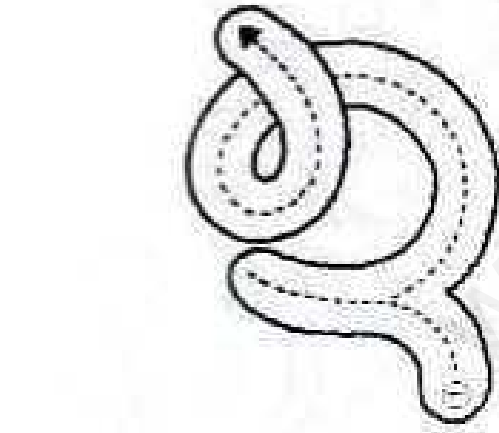

oso

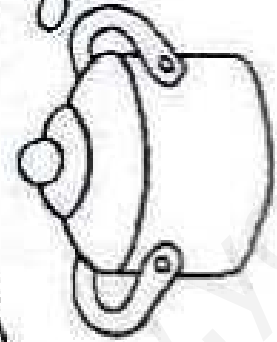

olla

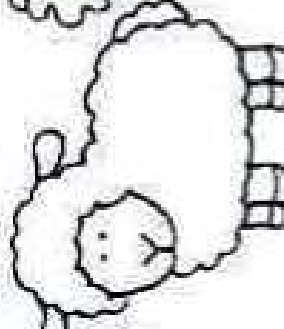

ovija

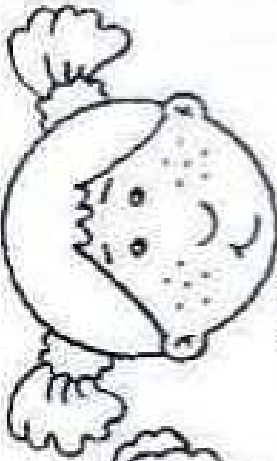

Olivia

- DELINEA Y COMPLETA CADA RENGLÓN.



• DELINEA LAS VOCALES CON COLOR Y CÓPIALAS A LA DERECHA DE LA LÍNEA.

Letras
18

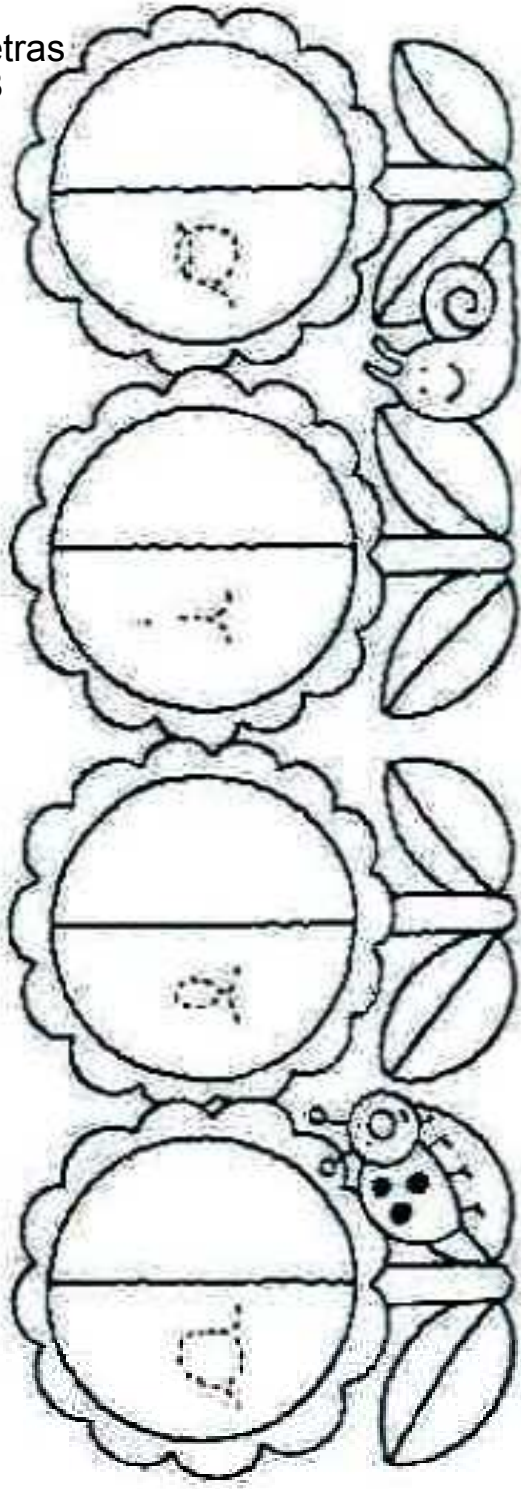

• DE LÍNEA FORTES PALABRAS.

• SUBRAYA TODAS LAS LETRAS "O" QUE CONTIENEN

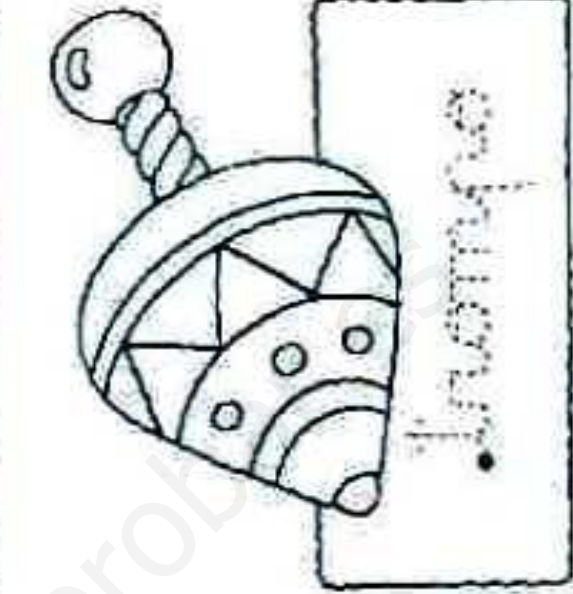
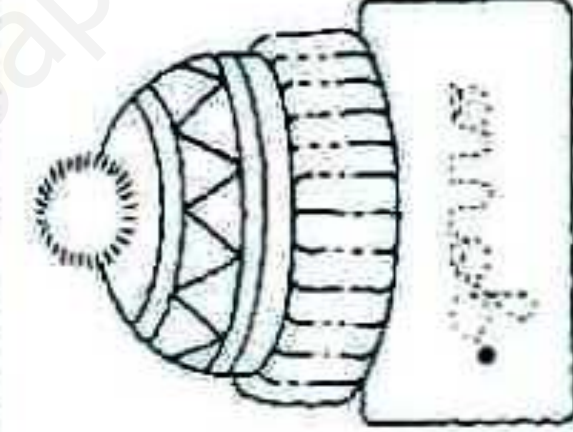
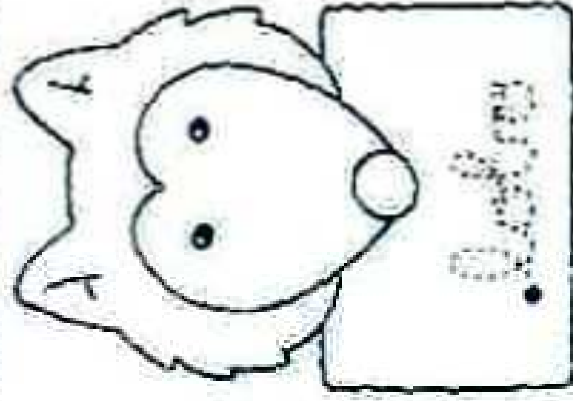
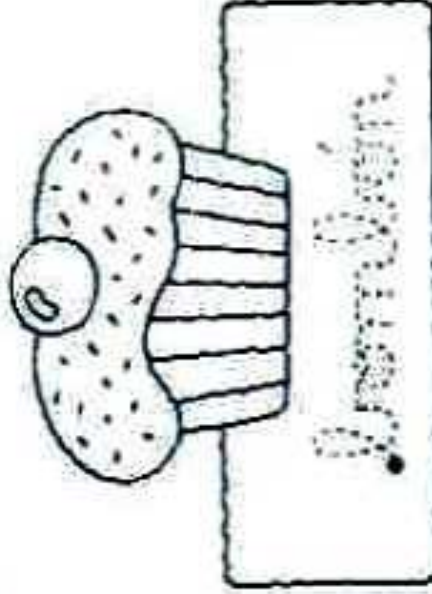
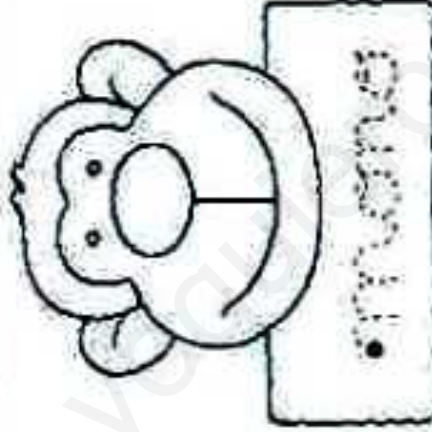
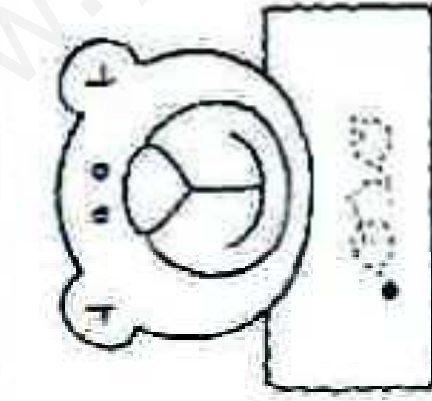

• DE LÍNEA Y COMPLETA CADA RELACION.

oso - o - oso - o - oso

oso



- RECORRE LAS LETRAS GRANDES CON TU DEDO ÍNDICE.
- DECORALAS CON PINTITAS DE DISTINTOS COLORES.

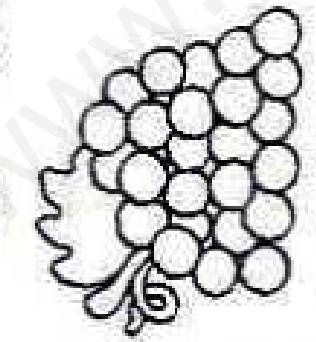
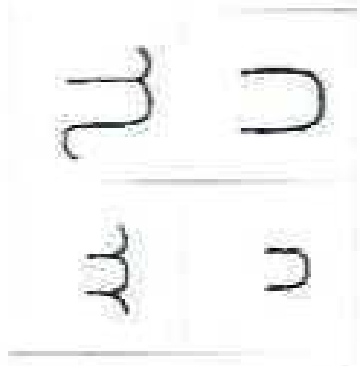
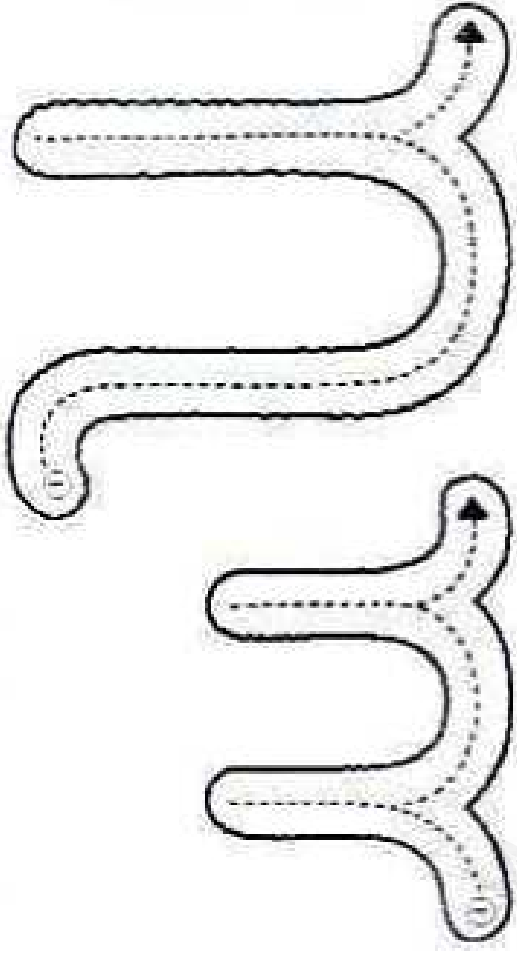

uvas

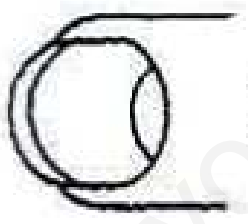

uñas

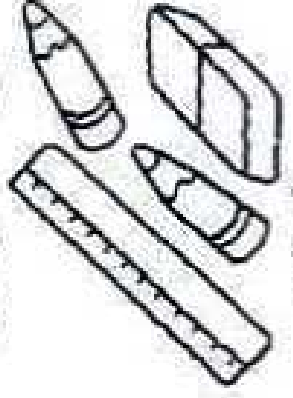

útiles

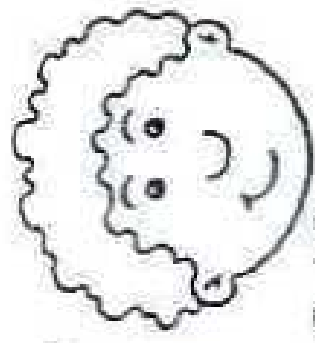

Ulises

• DELINEA Y COMPLETA CADA RENGLÓN.



Copyright © Probar.es

- COLOREA LAS VOCALES SIGUIENDO LA DIRECCIÓN CORRECTA.
- UNE CON UNA LÍNEA DE COLOR CADA OBJETO CON LA LETRA INICIAL CORRESPONDIENTE.

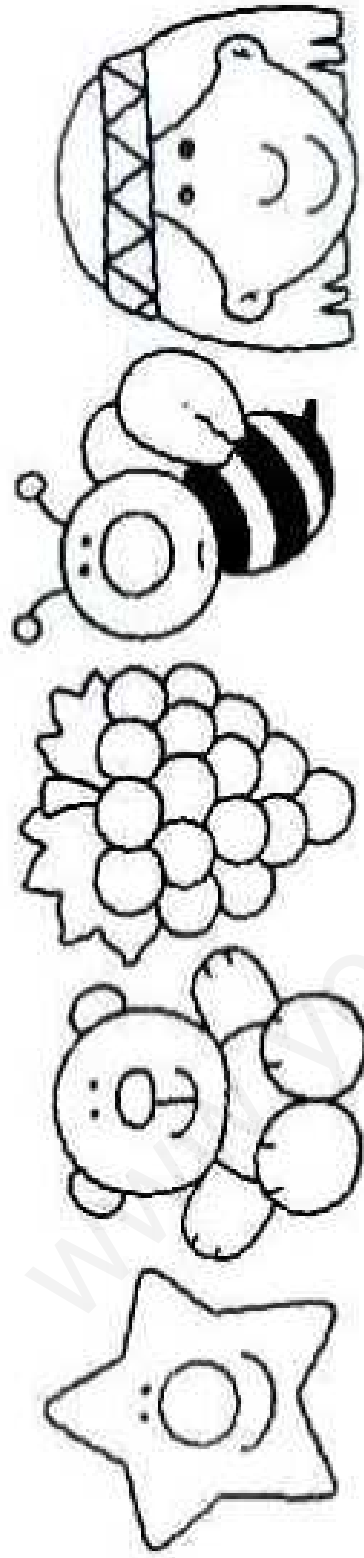
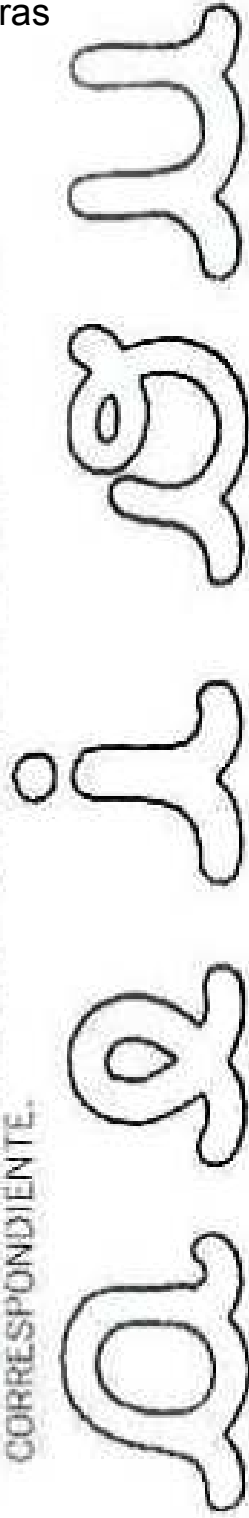

- DELINEA LAS LETRAS DEL ABECEDARIO. ESCRIBE CON COLOR LAS VOCALES QUE FALTAN.

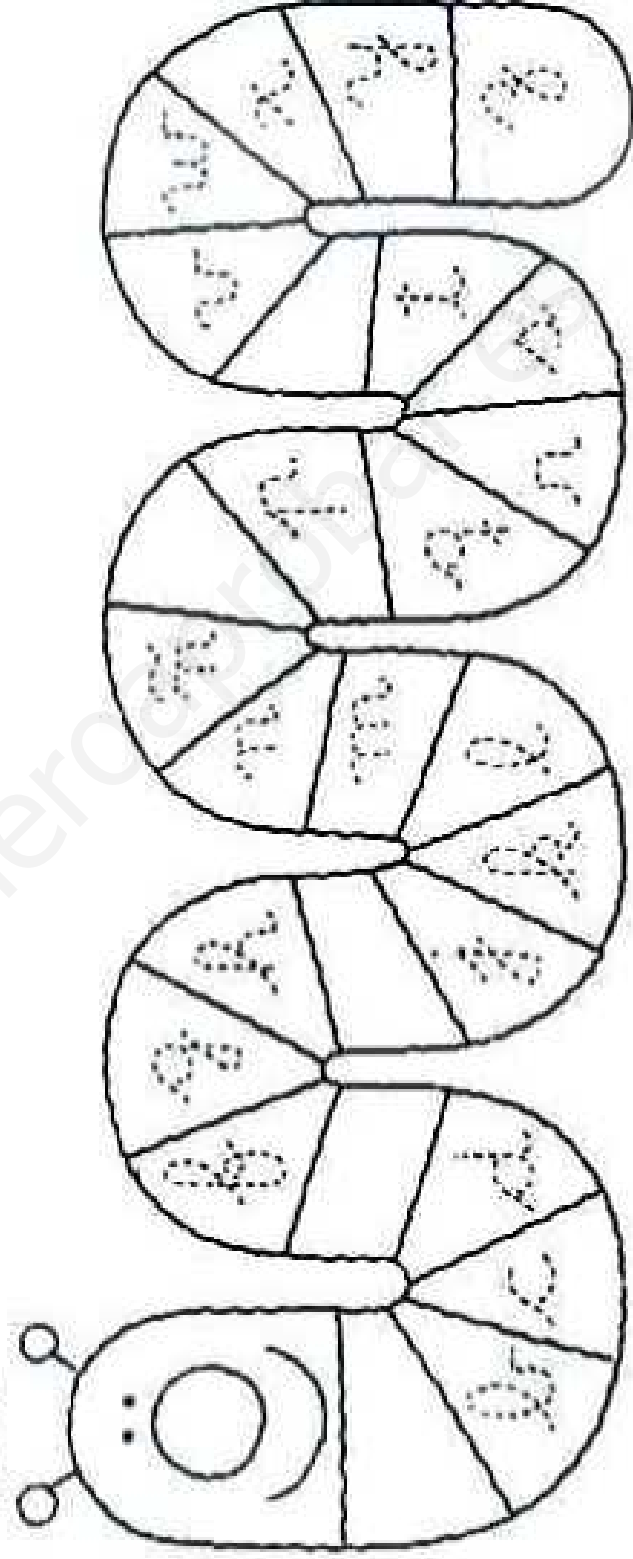

- DELINEA Y CÓMPLETA CADA RENGLÓN MIENTRAS VOCALIZAS LOS SONIDOS.

a i e u a i e u a i e u a i e u a i e u

a i e u

a i e u

- RECORRE LAS LETRAS GRANDES CON TU DEDO ÍNDICE.
- DECÓRALAS COMO MÁS TE GUSTE.

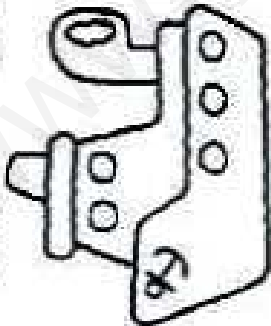
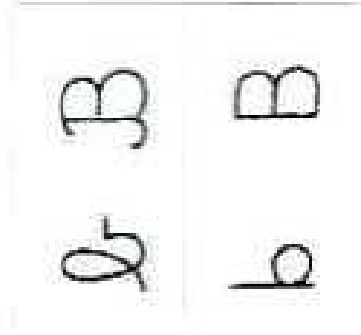
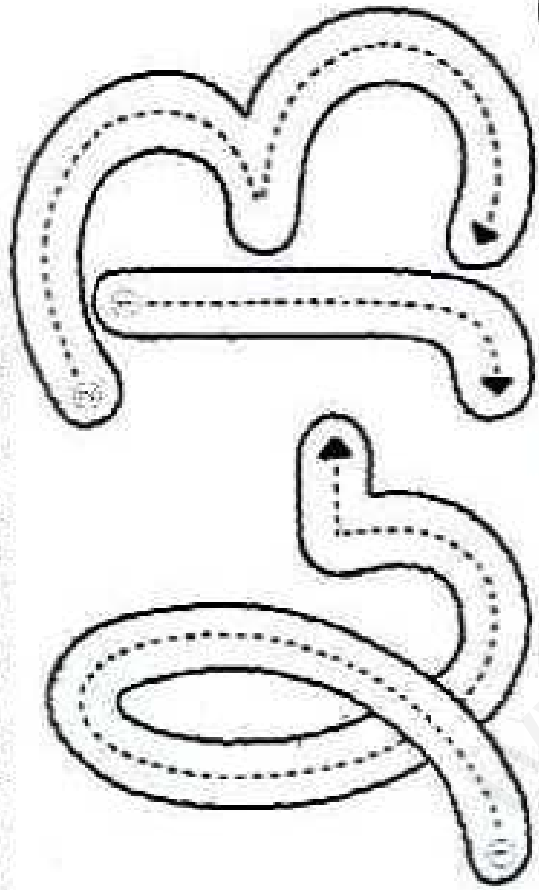

barco

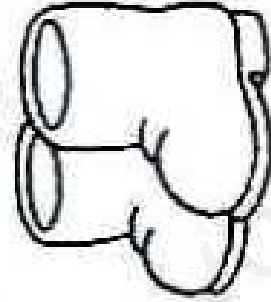

botas

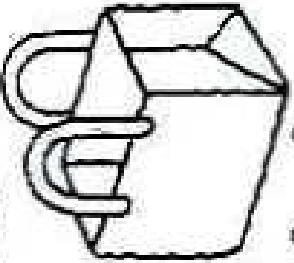

bolsa

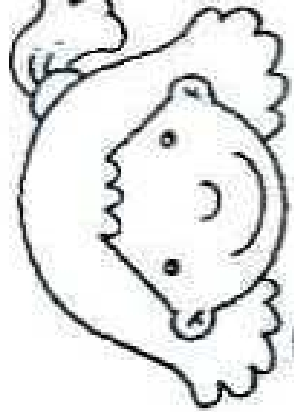

Beatriz

DELINEA Y COMPLETA CADA RENGLÓN.

b b ba be bi bo bu

b b b b b b b b b b

a b c d e f g h i j k l m n ñ o p q r s t u v w x y z

Probar.es

- REPITE EN VOZ ALTA EL NOMBRE DE CADA OBJETO.
- COLOREA LOS OBJETOS QUE COMIENZAN CON "B".
- ESCRIBE LA LETRA "B" DEBAJO DE CADA UNO DE ELLOS.

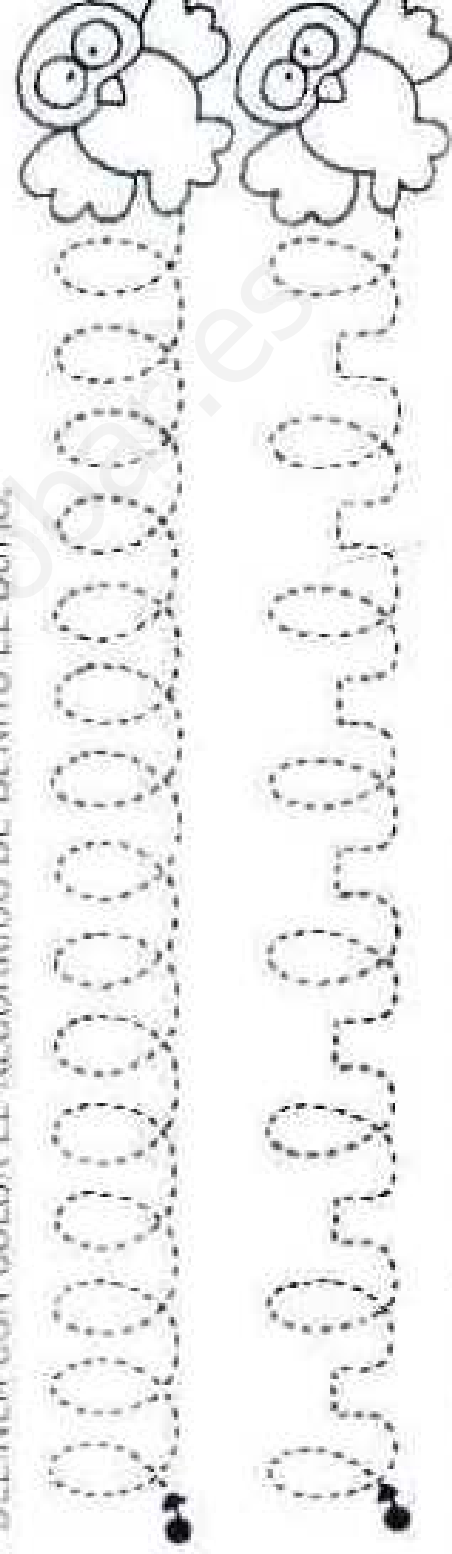
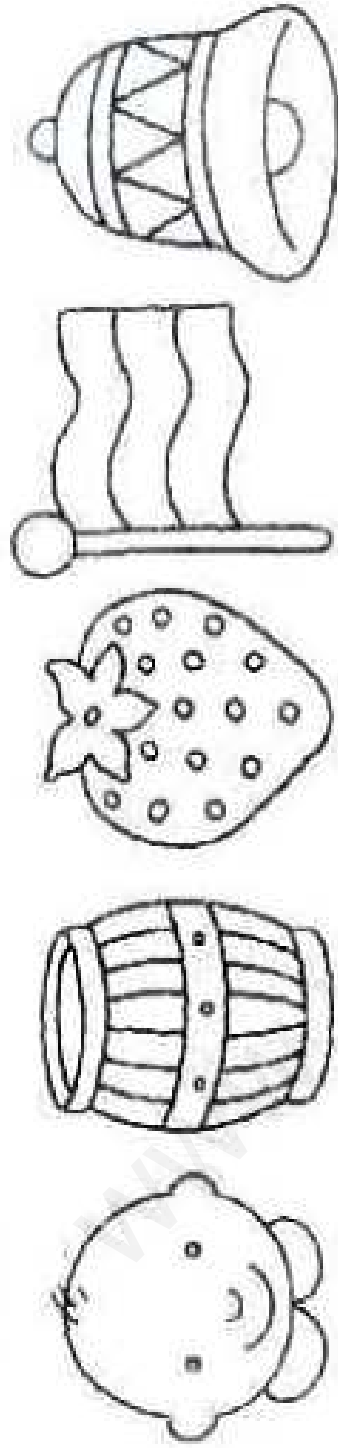

- DELINEA CON COLOR EL RECORRIDO DE BENITO EL BUHO.

- ESCRIBE LA SÍLABA INICIAL DE CADA OBJETO EN LETRA CURSIVA.

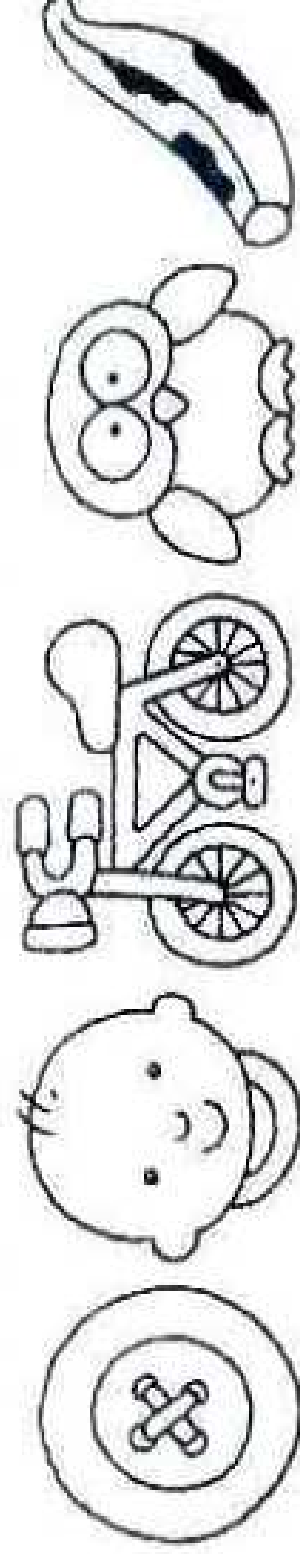

- RECORRE LAS LETRAS GRANDES CON TU DEDO ÍNDICE
- DECÓRALAS CON LUNARES ROJOS Y AMARILLOS.

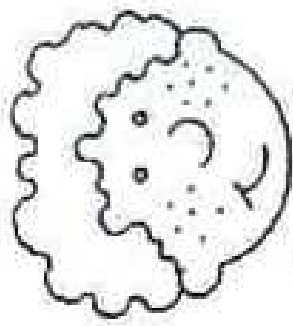
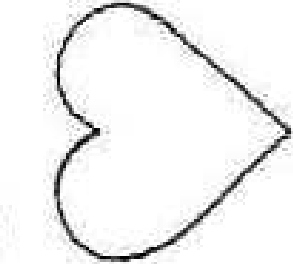
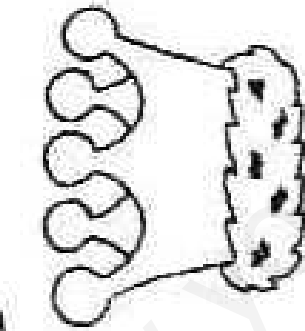
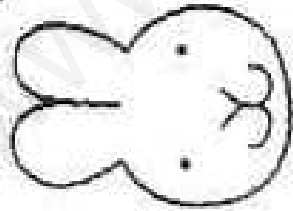
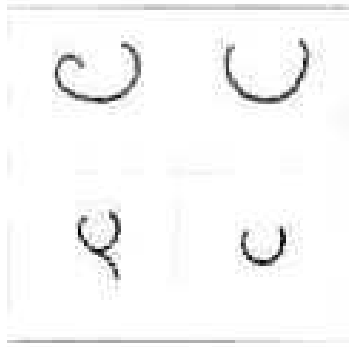
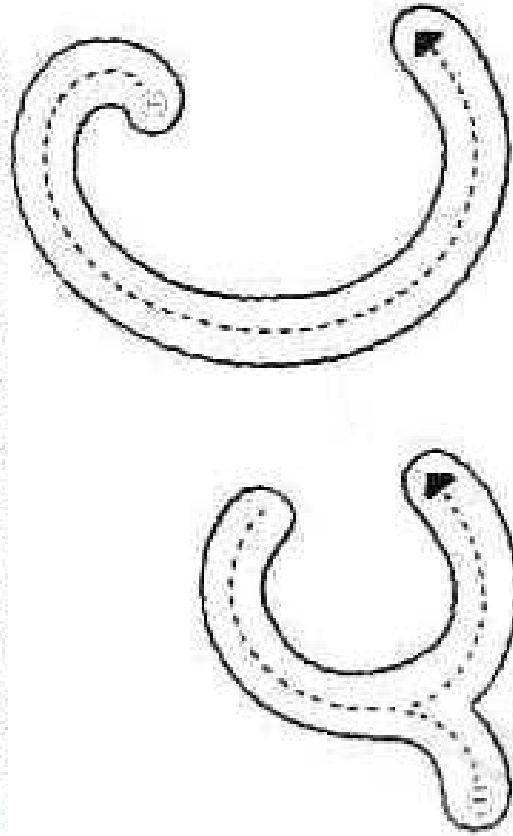

conejo corona corazón Carlos

- DELINEA Y COMPLETA CADA RENGLÓN

c

c

ca

ca

cu

ce

ci

a b c d e f g h i j k l m n ñ o p q r s t u v w x y z

www.dinor.com.co



• COLOREA LAS LETRAS EN LA DIRECCIÓN CORRECTA.

• LUEGO COLOREA EN CADA RENGLÓN LOS OBJETOS CUYOS NOMBRES COMIENZAN CON LA LETRA CORRESPONDIENTE.

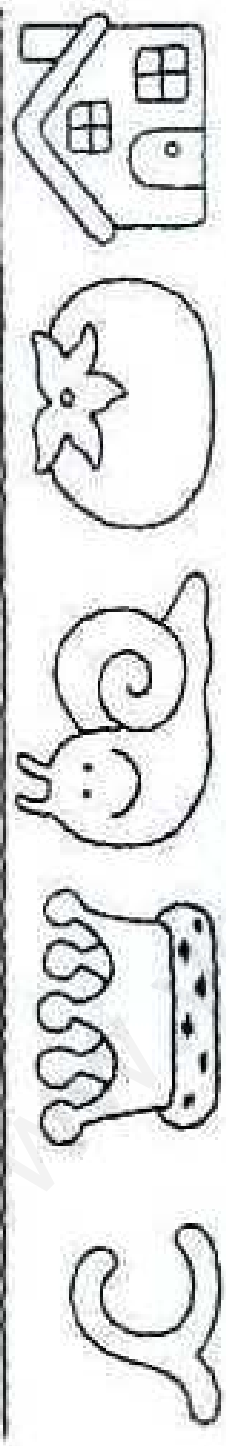
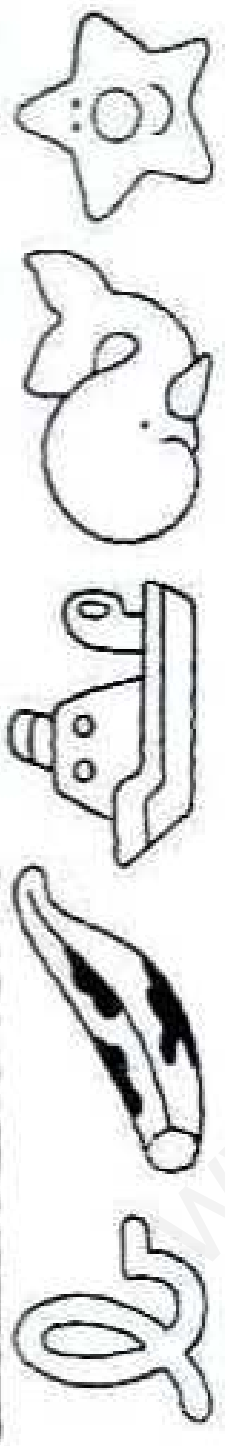
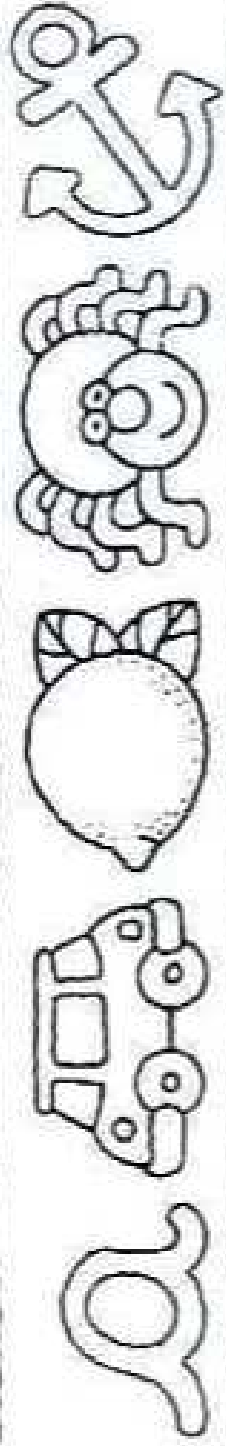

• DELINEA EL RECORRIDO DE CARLITOS EL CARACOL.

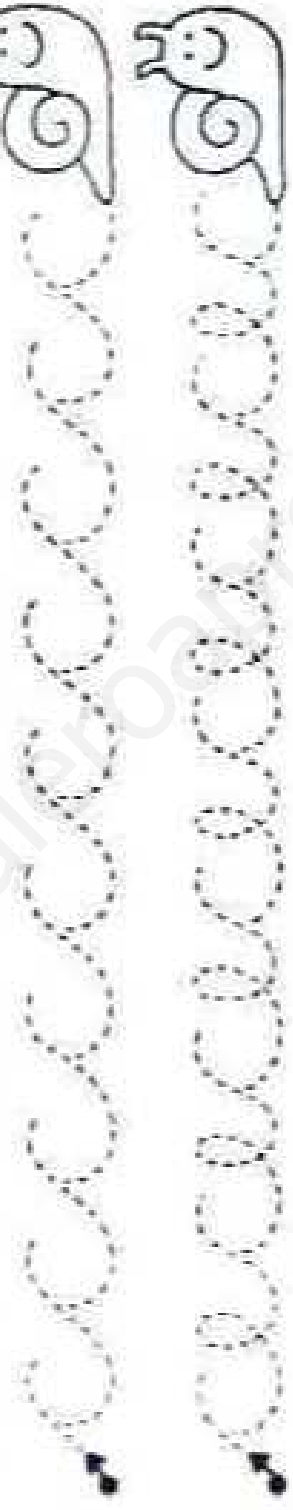

• DELINEA CADA PALABRA MIENTRAS LA LEES EN VOZ ALTA.

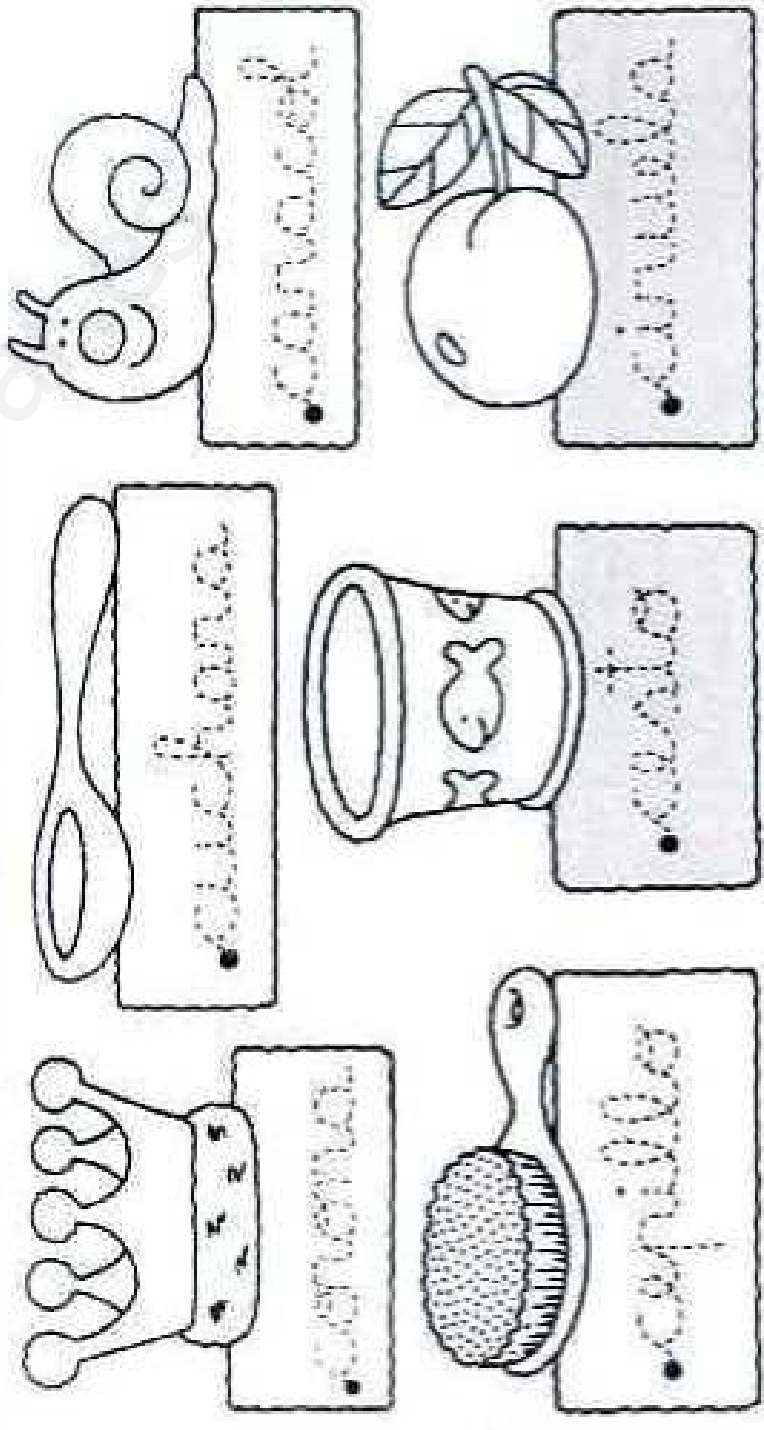

- RECORRE LAS LETRAS GRANDES CON TU DEDO ÍNDICE.
- DECÓRALAS COMO MÁS TE GUSTE.

a b c d e f g h i j k l m n ñ o p q r s t u v w x y z

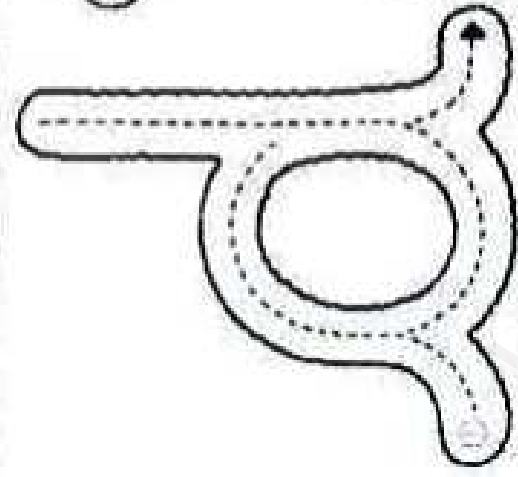

dulce

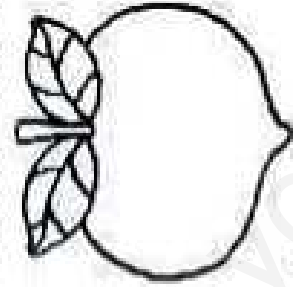

durazno

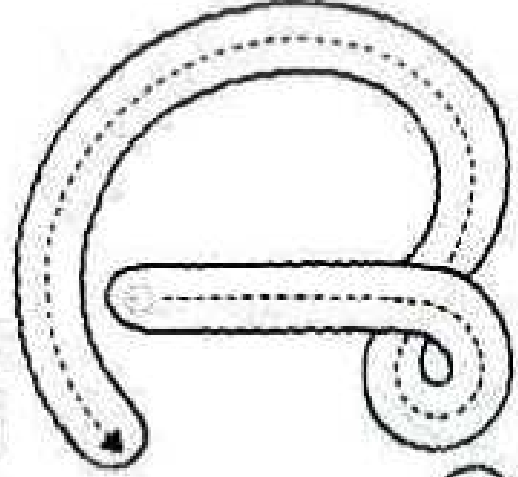

dado



Diego

d

D

d

D

• DELINEA Y COMPLETA CADA RENGLÓN.

d

da

de

di

do

du

d d d d d d d d d d d d d d d d

PapProbar.es

• SILOREA CADA LETRA SIGUIENDO LA DIRECCIÓN CORRECTA.
• RAZA UN RECORRIDO DESDE LAS LETRAS AL OBJETO CORRESPONDIENTE.

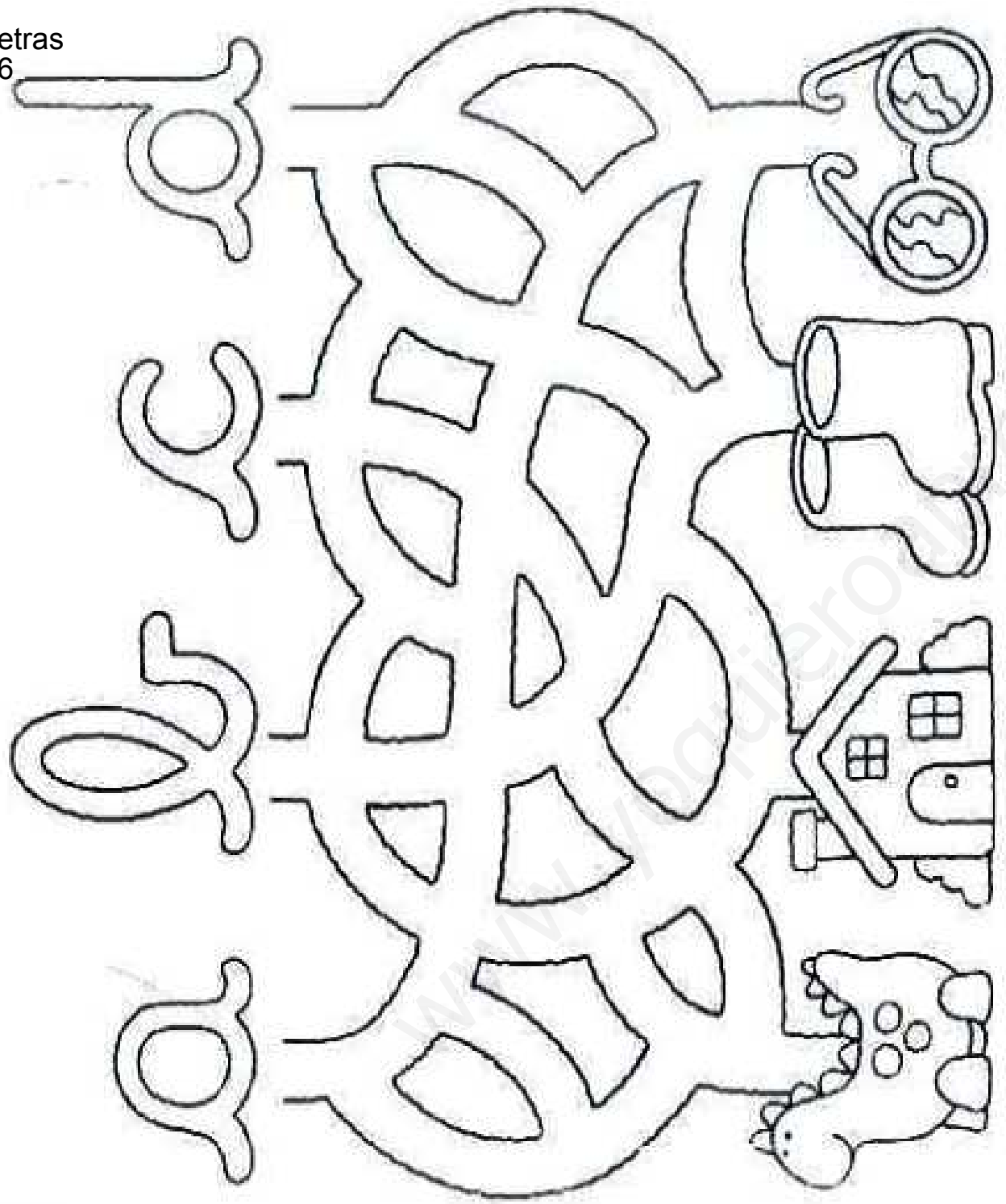

• DELINEA CADA PALABRA MIENTRAS LA DELETREAS EN VOZ ALTA.

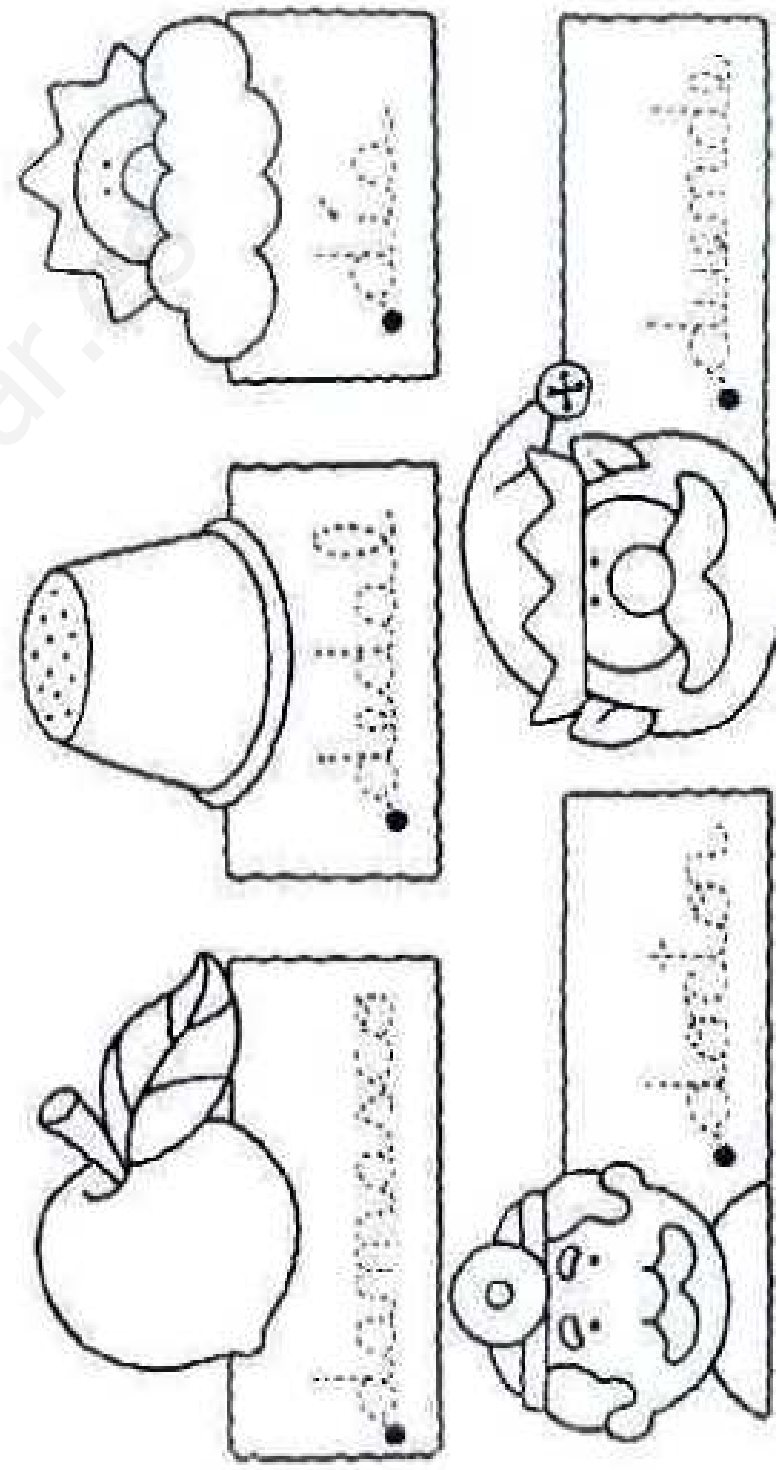

- RECORRE LAS LETRAS GRANDES CON TU DEDO INDICE.
- DECÓRALAS CON LANA.

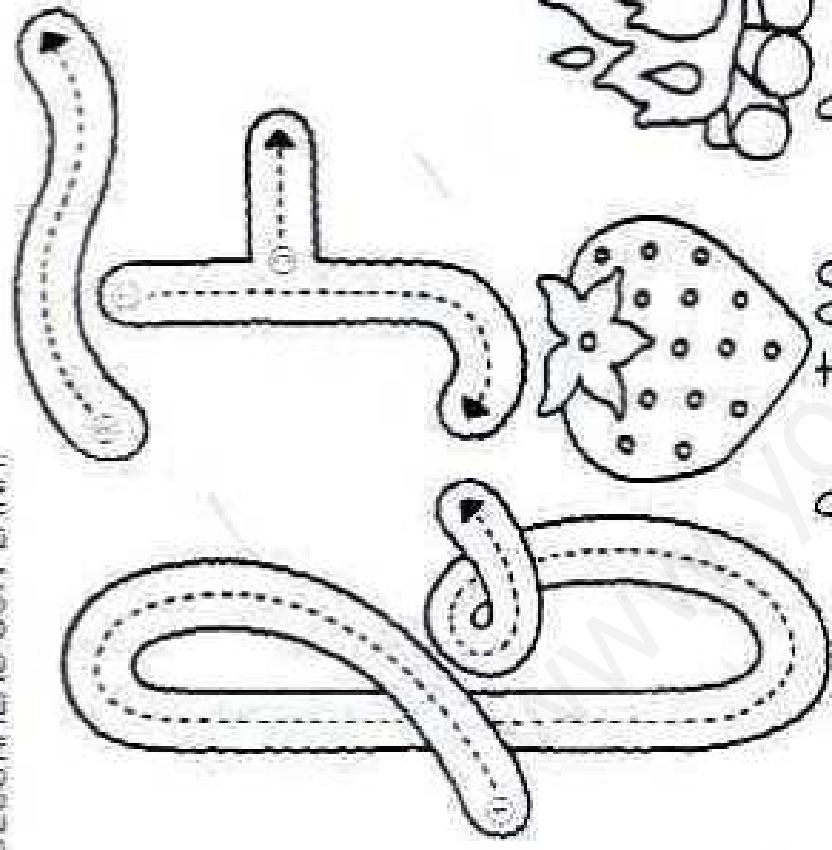

f F
F F

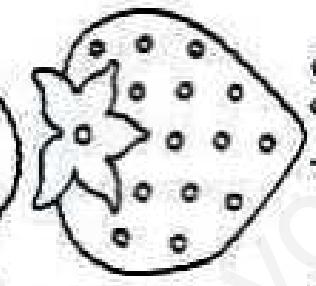

frutilla

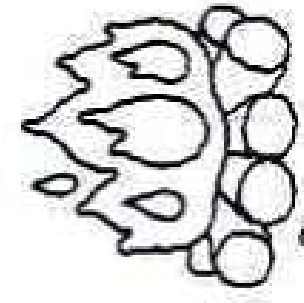

fuego

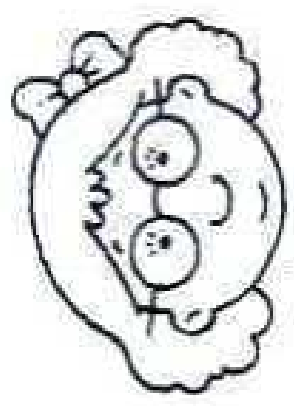

Flavia

- DELINEA Y COMPLETA CADA RENGLÓN.

f fa fe fi fo fu



a b c d e f g h i j k l m n ñ o p q r s t u v w x y z

• COMPLETA LOS CASILLEROS CON LA LETRA INICIAL DE CADA OBJETO. USA ESTAS LETRAS PARA FORMAR LA ÚLTIMA PALABRA.

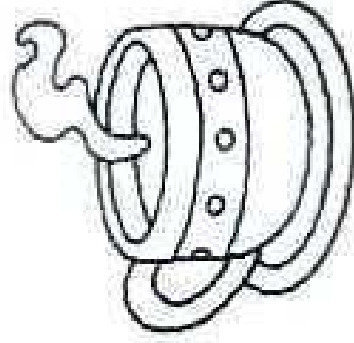
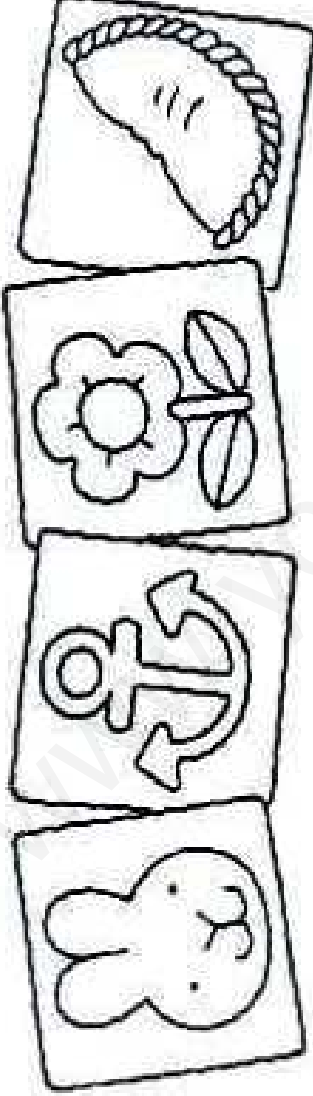
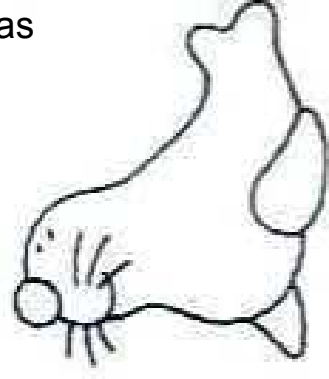
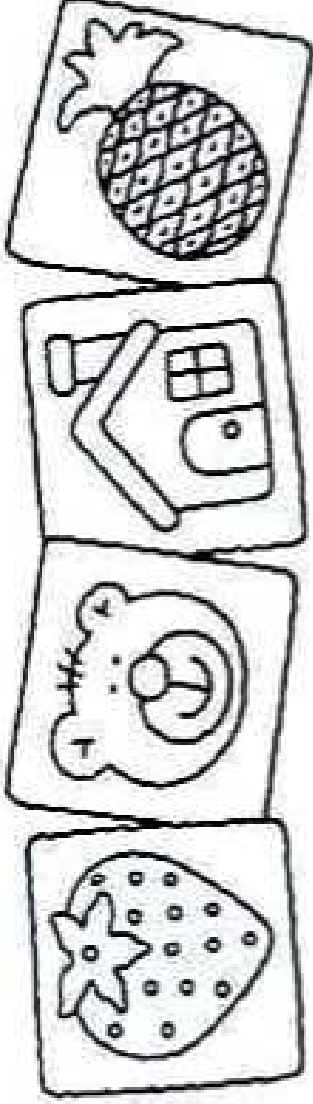

• DELINEA LAS SILABAS IGUALES CON EL MISMO COLOR.

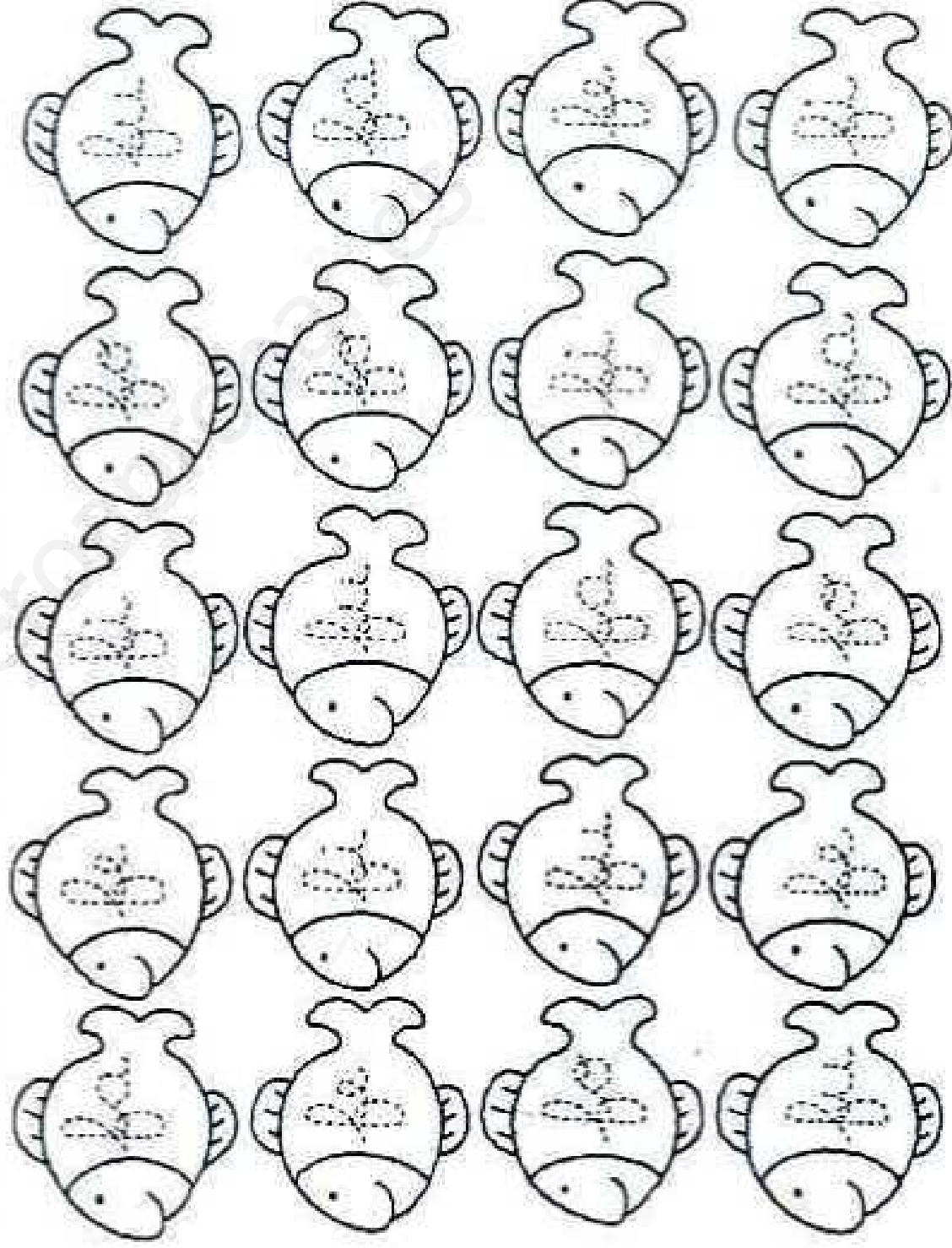

- RECORRE LAS LETRAS GRANDES CON TU DEDO INDICE.
- DECÓRALAS CON CÍRCULOS DE COLORES ALTERNADOS.

a b c d e f g h i j k l m n ñ o p q r s t u v w x y z

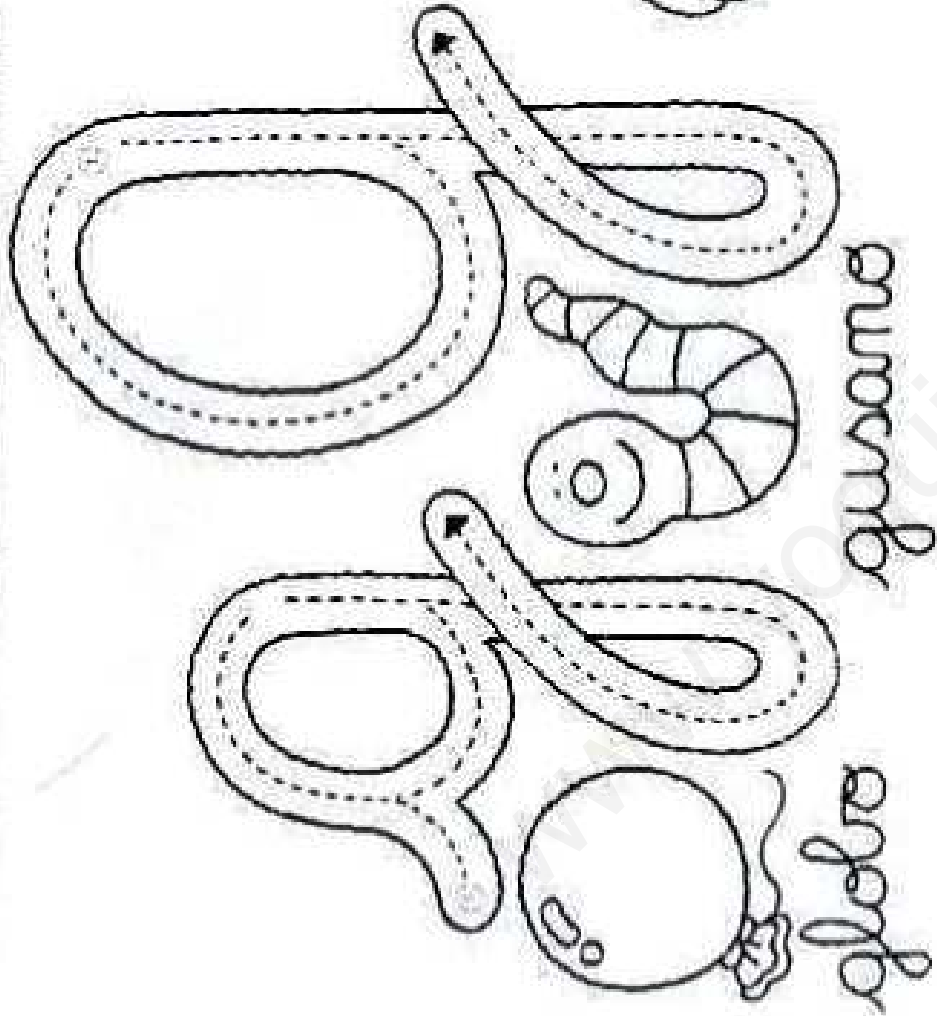

g G

g G

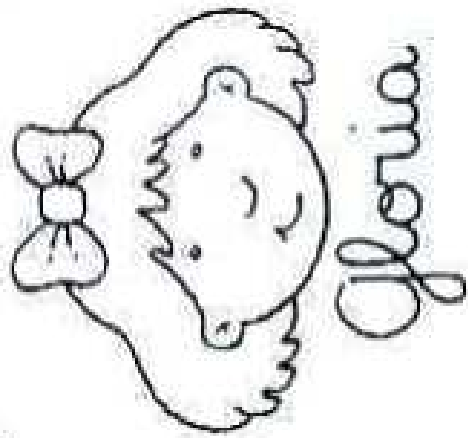

Gloria

• DELINEA Y COMPLETA CADA RENGLÓN.

g g ga go gu ge gi

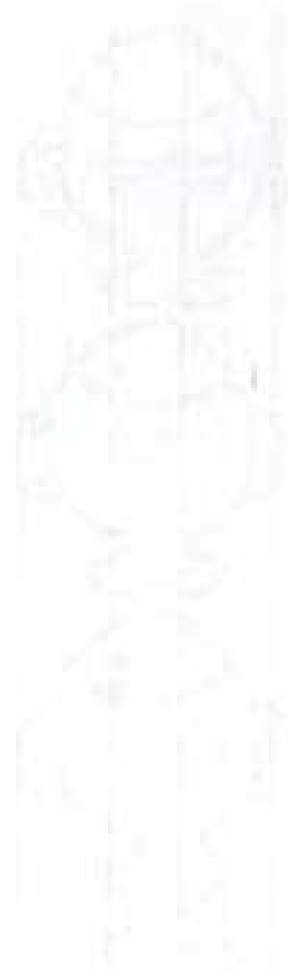

- DELINEA LAS LETRAS DE CADA FICHA.
- UNE CON UNA LÍNEA SEGÚN CORRESPONDE.

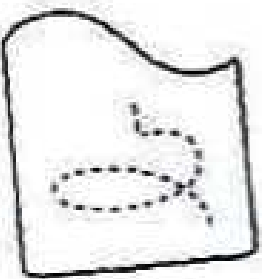
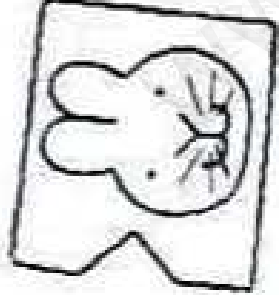
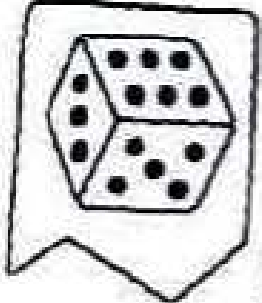
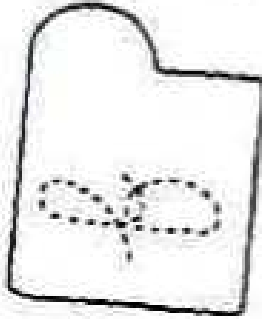
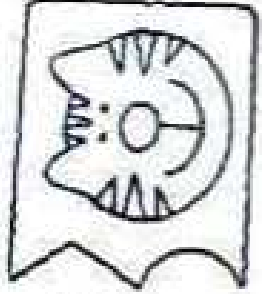
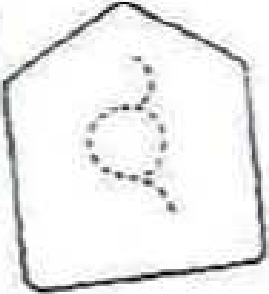
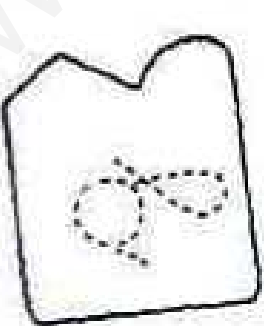
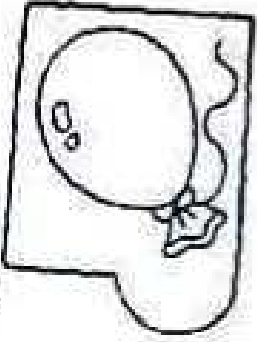
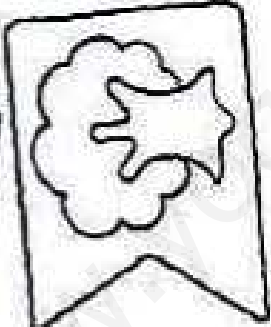
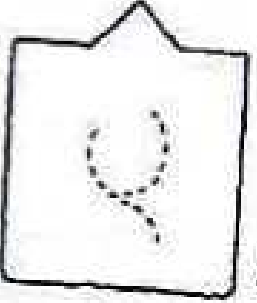
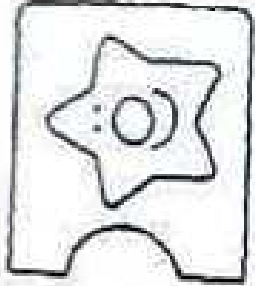
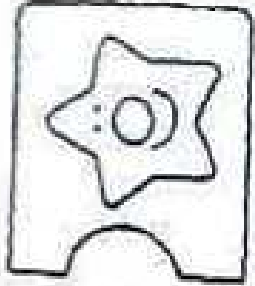
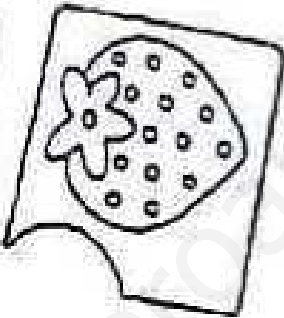
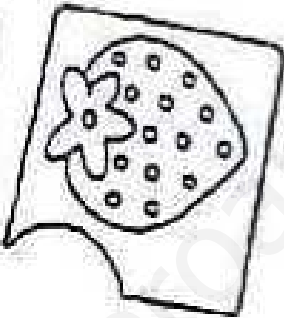
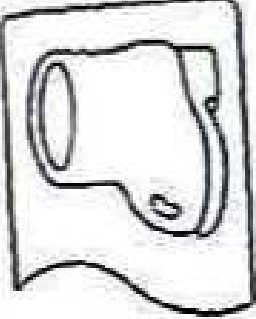
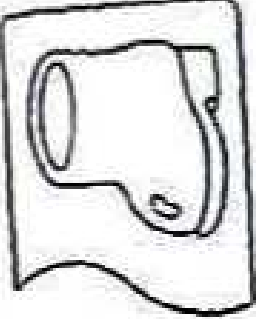
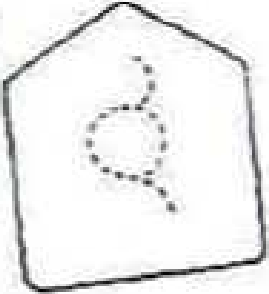
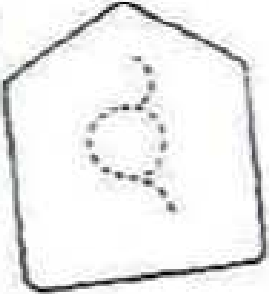
- DELINEA CON COLOR CADA PALABRA MIENTRAS LA LEES EN VOZ ALTA.

					
					
					
					
					
					
					
					
					
					
					
					
					
					
					
					
					
					
					
					
					
					
					
					
					
					
					
					
					
					
					
					
					
					
					
					
					
					
					
					
					
					
					
					
					
					
					
					
					
					
					
					
					
					
					
					
				 </	

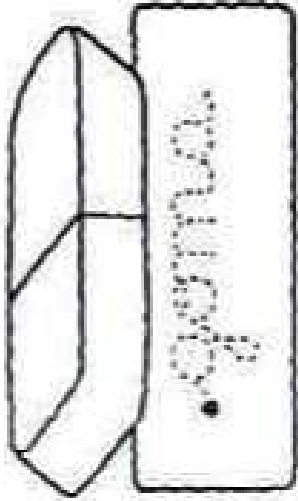
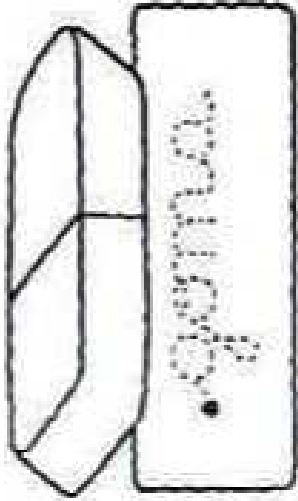
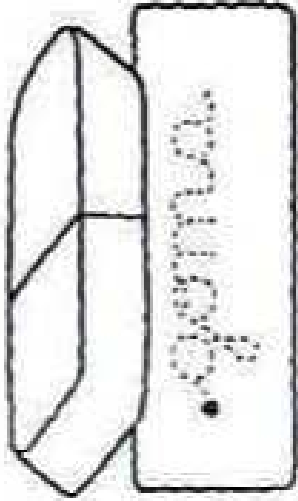
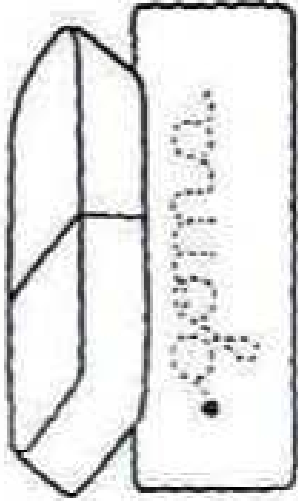
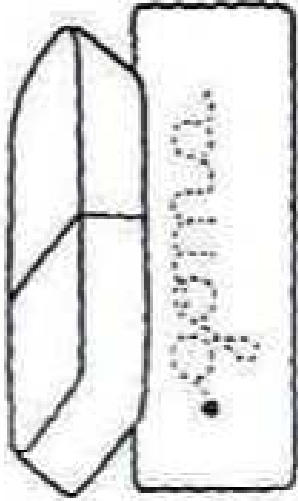
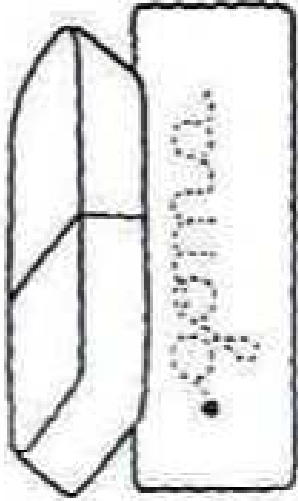
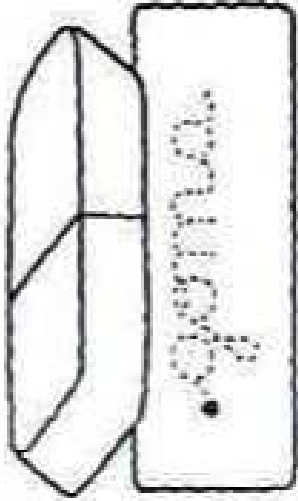
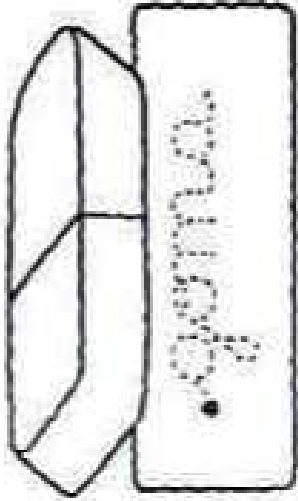
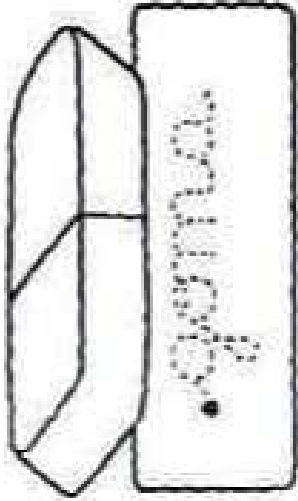
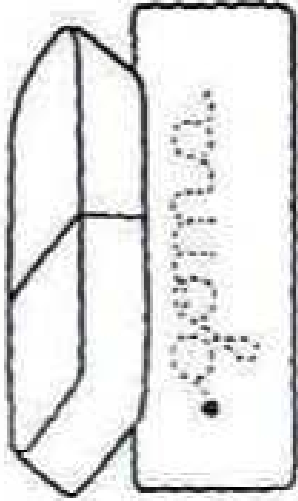
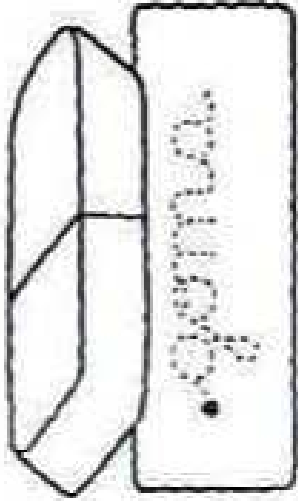
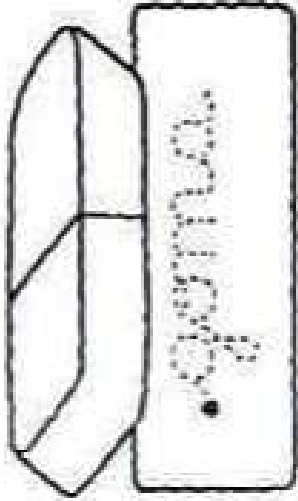
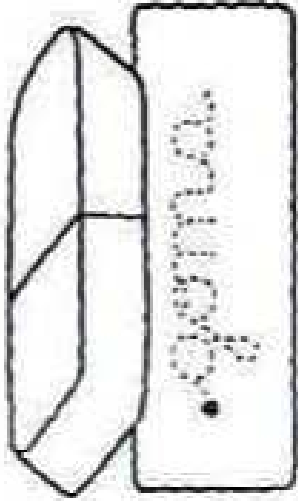
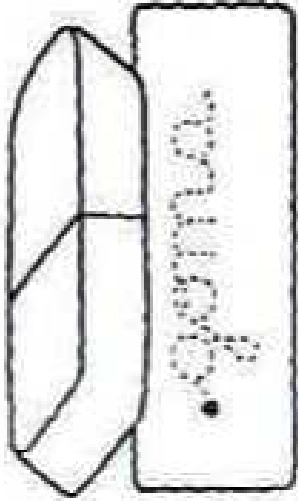
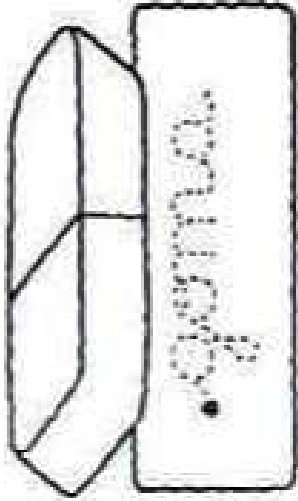
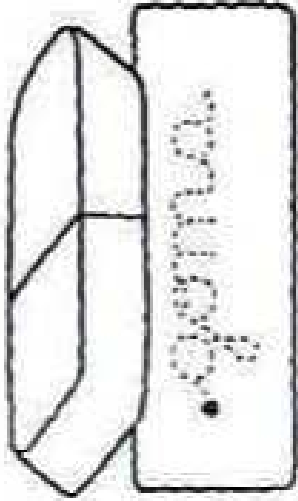
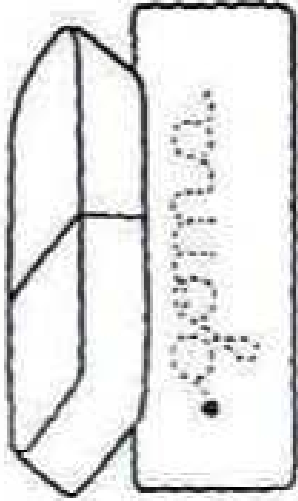
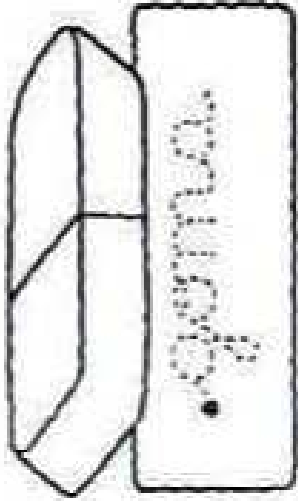
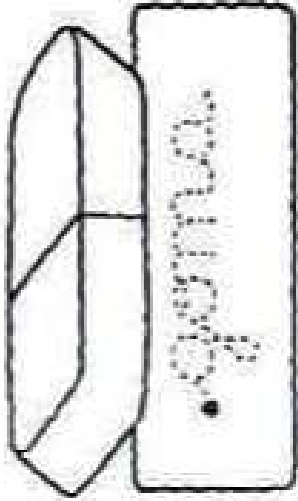
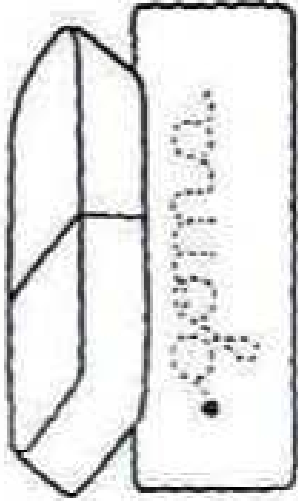
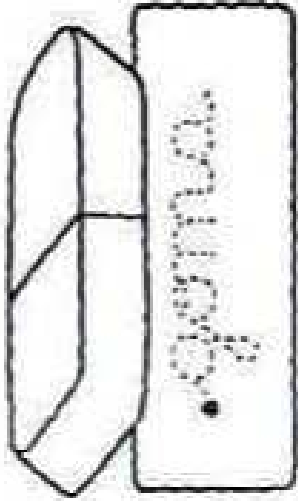
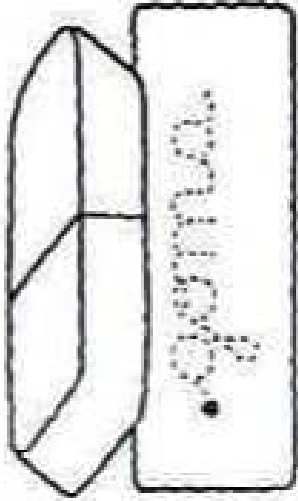
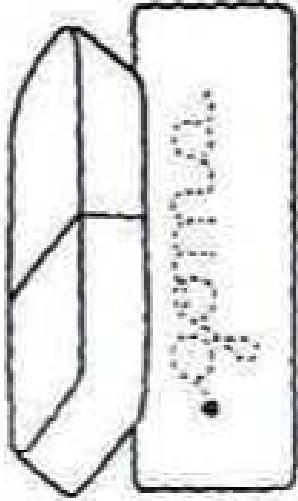
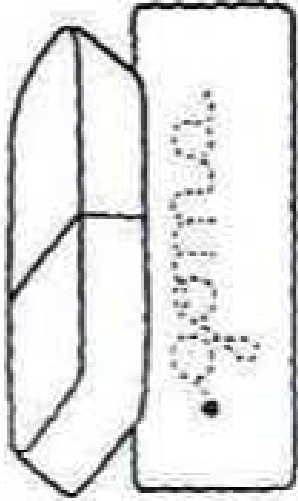
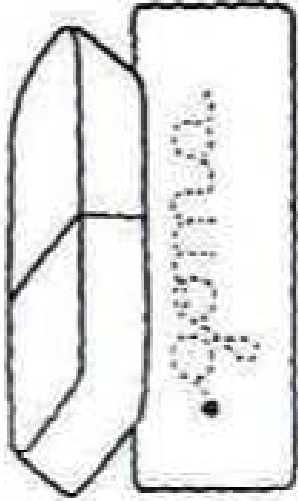
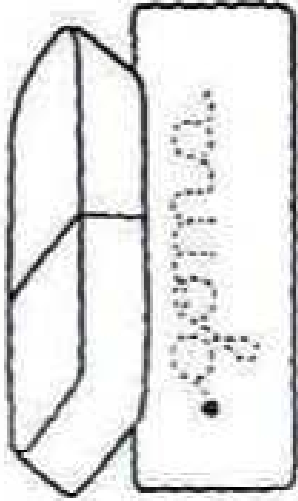
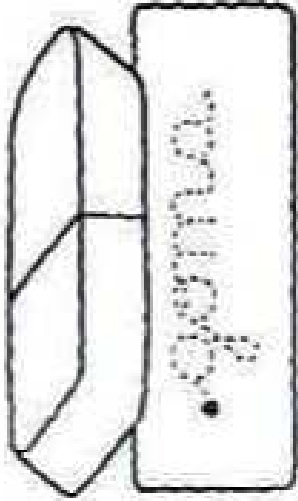
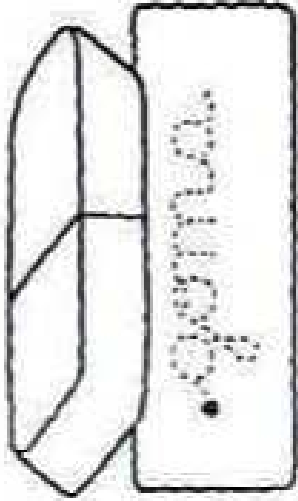
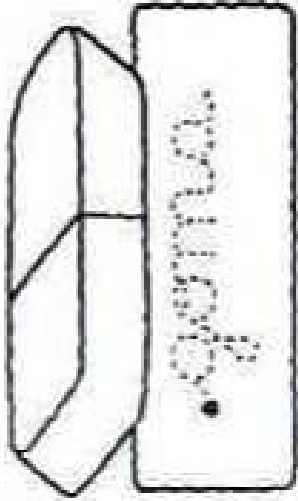
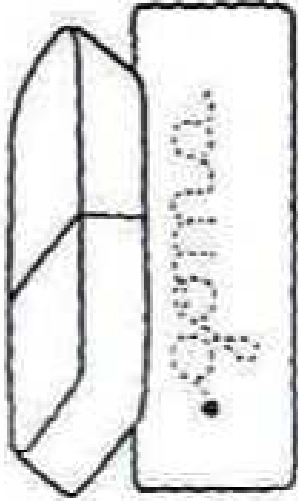
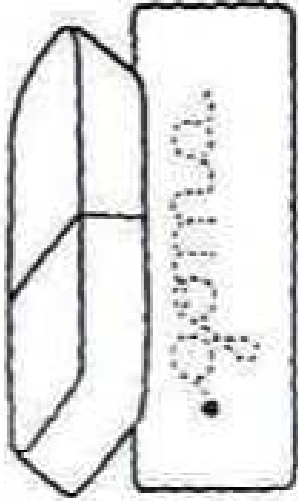
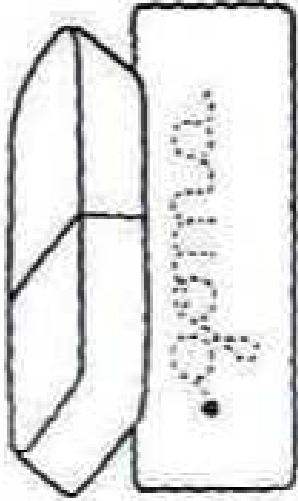
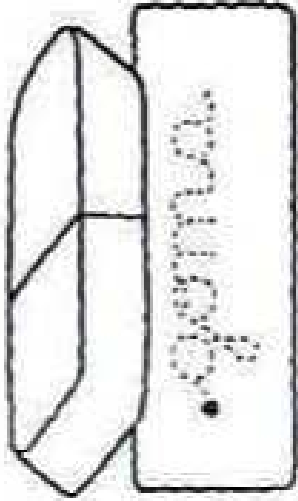
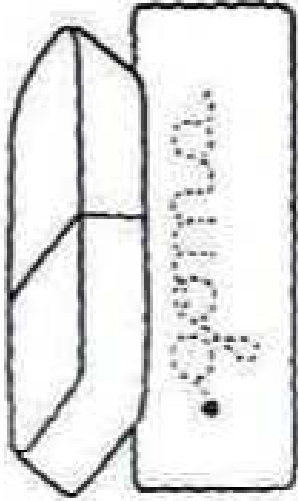
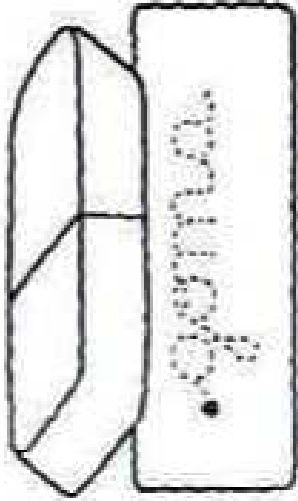
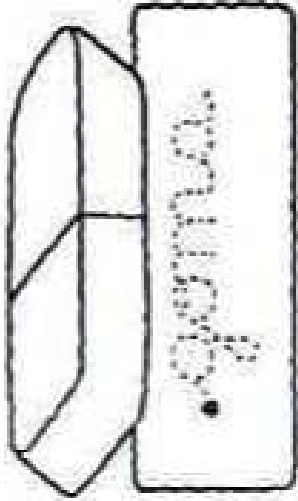
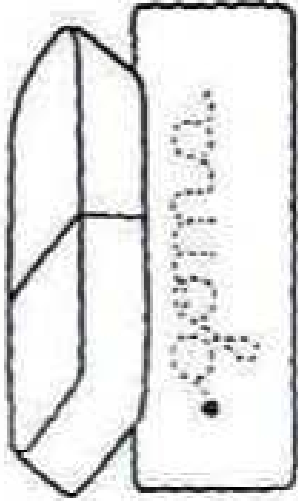
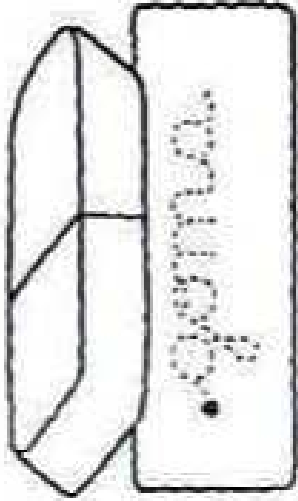
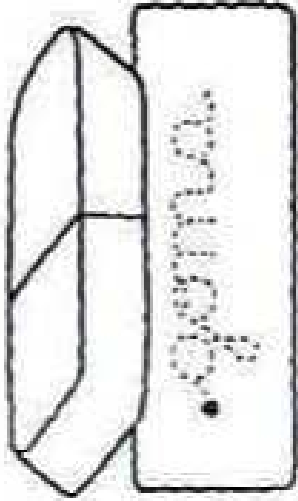
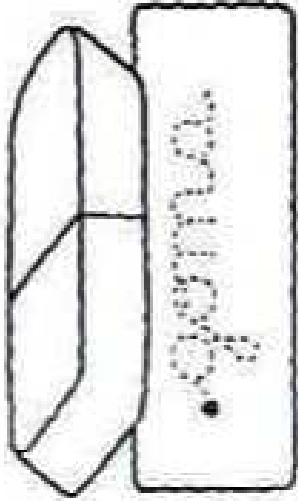
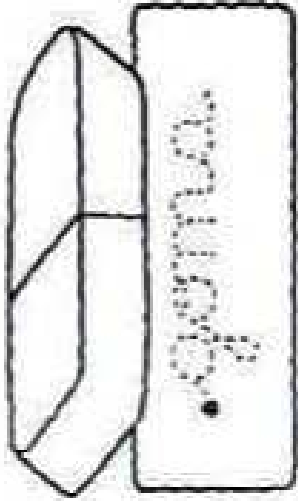
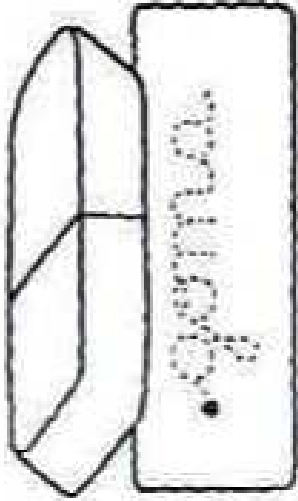
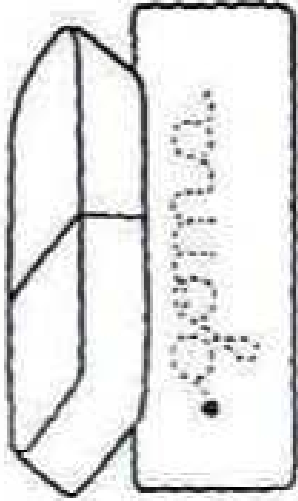
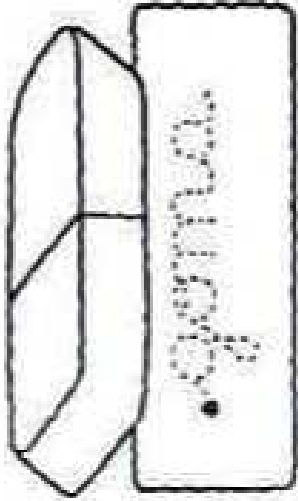
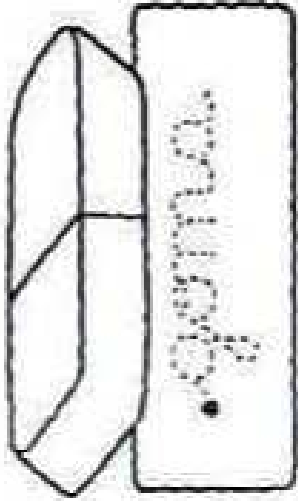
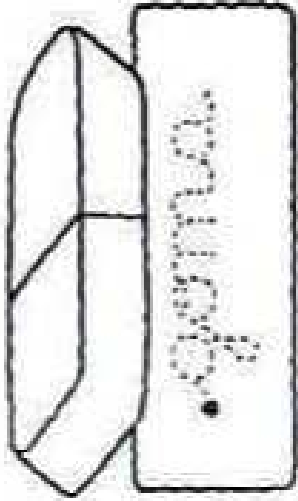
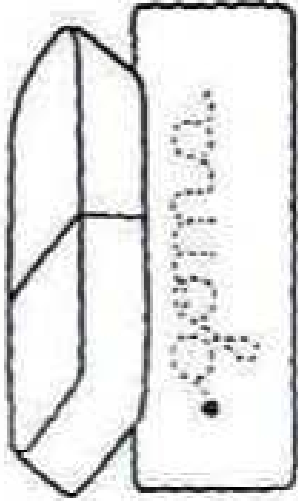
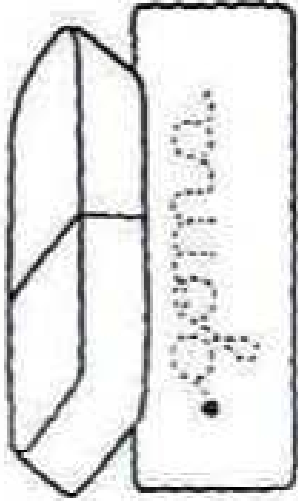
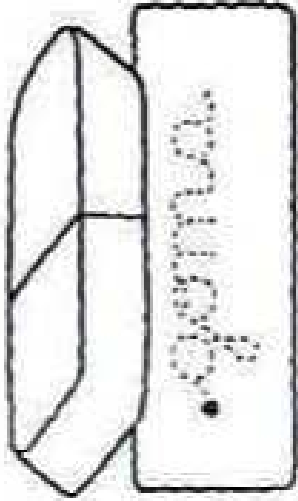
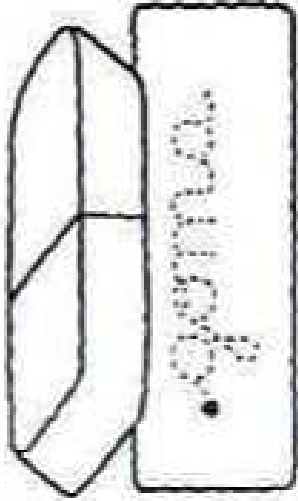
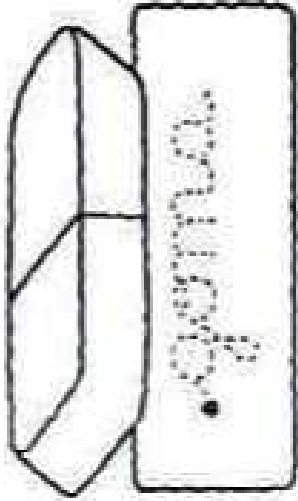
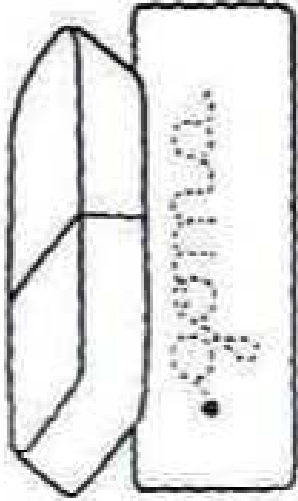
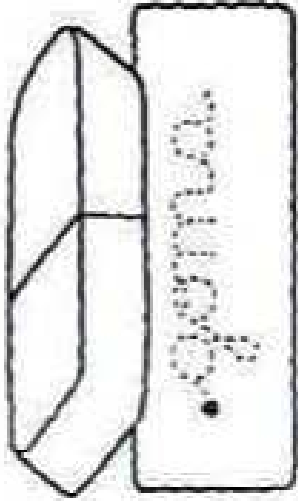
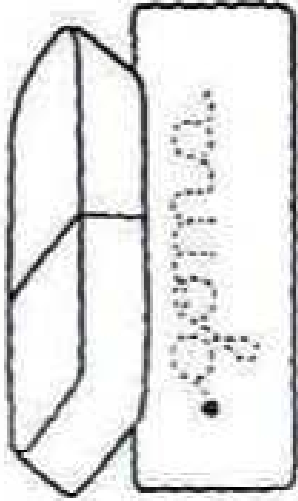
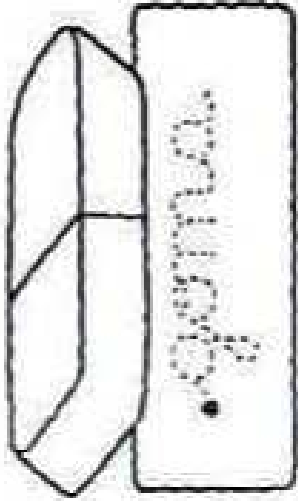
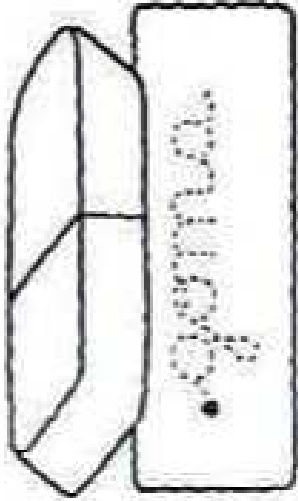
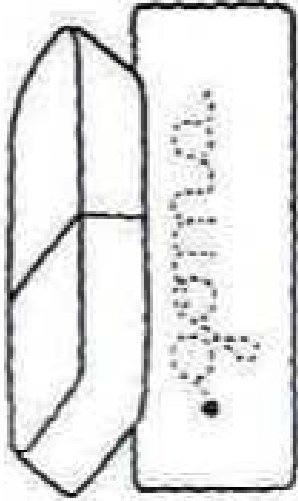
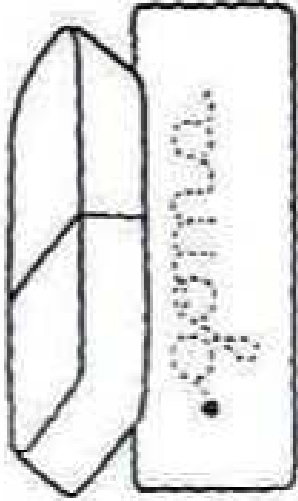
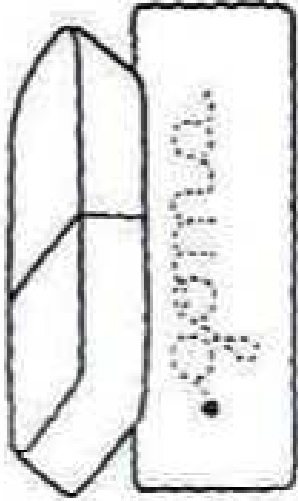
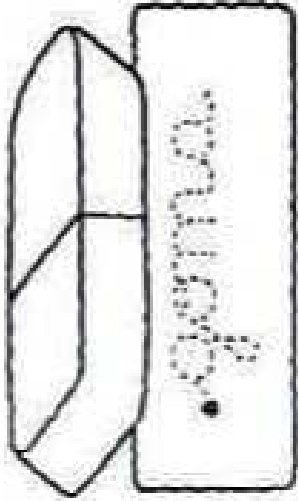
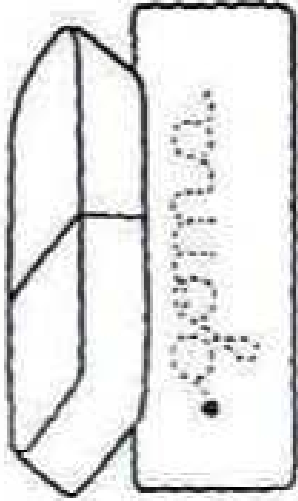
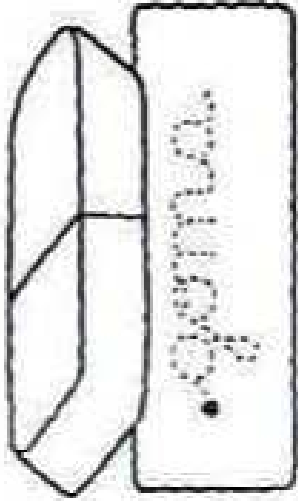
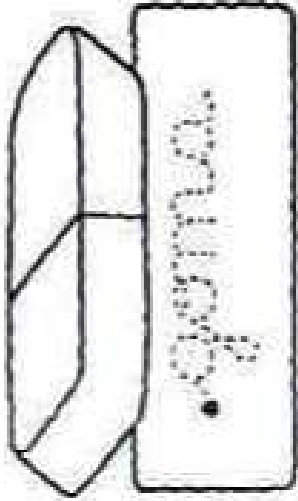
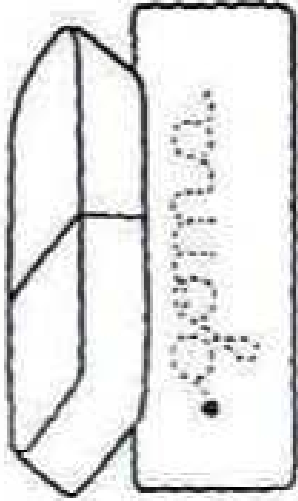
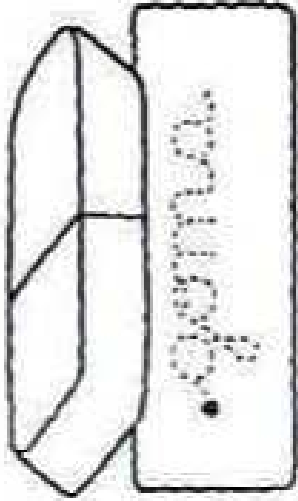
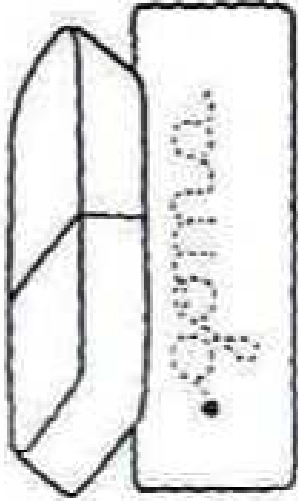
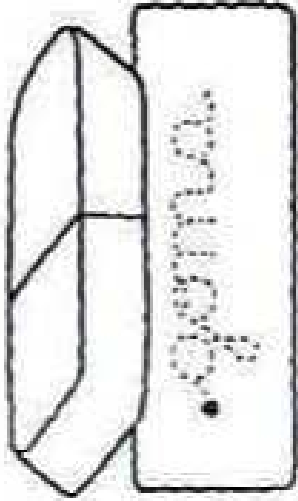
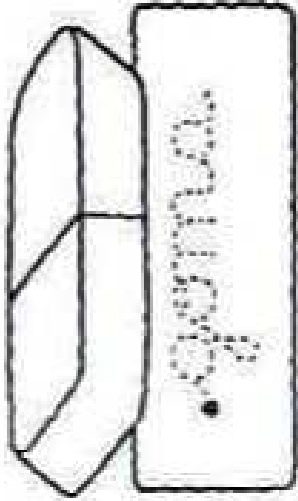
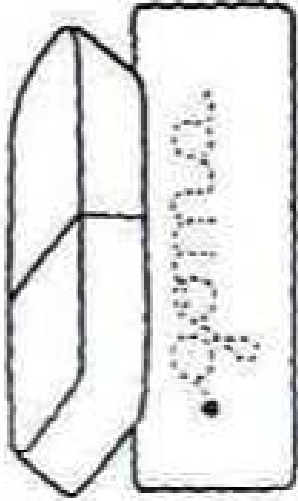
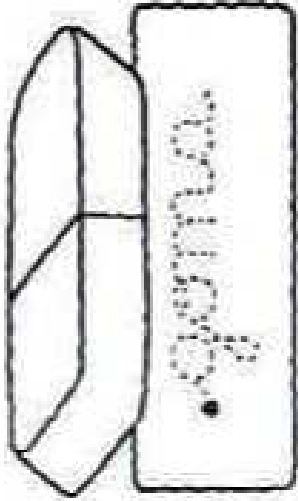
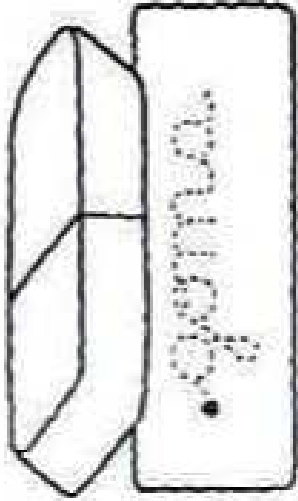
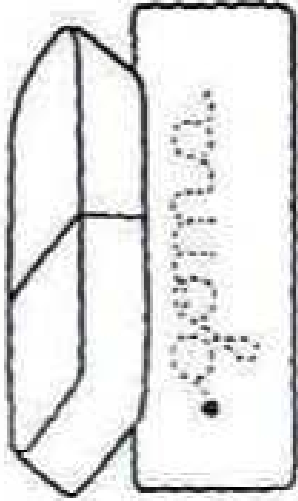
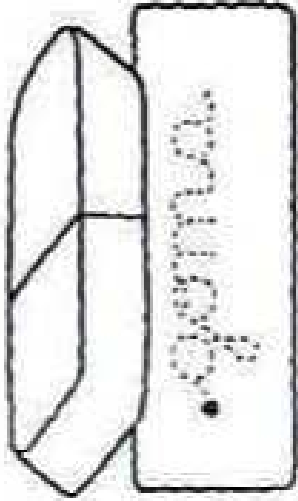
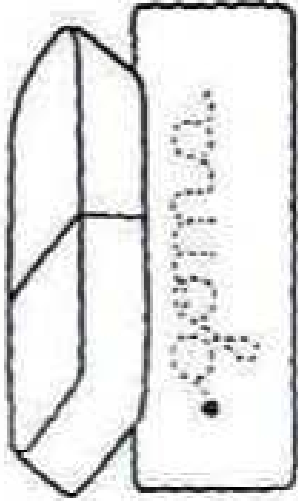
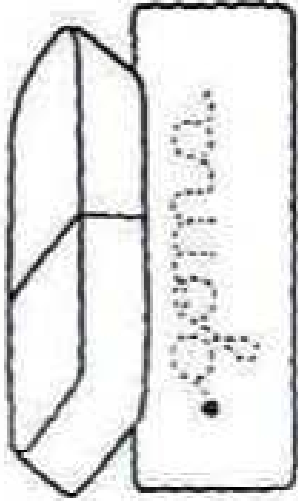
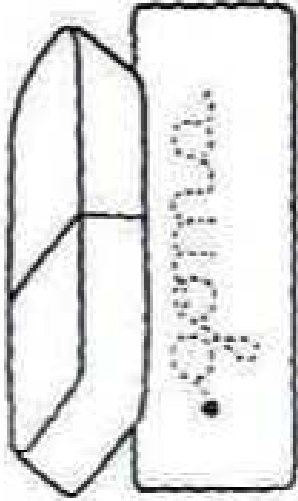
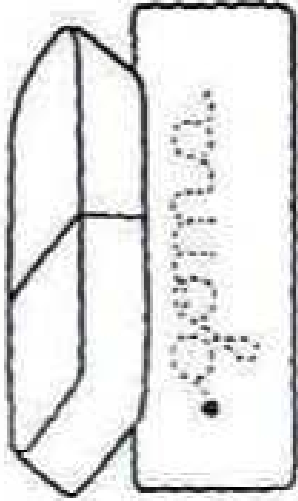
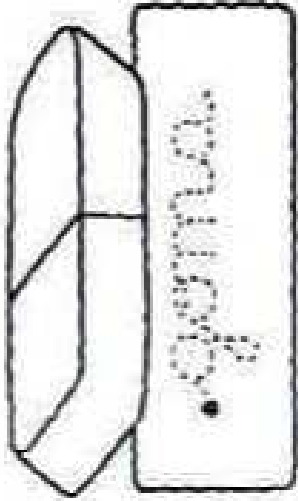
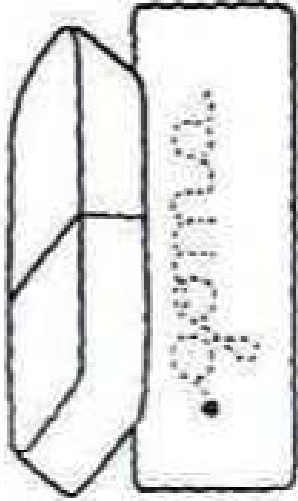
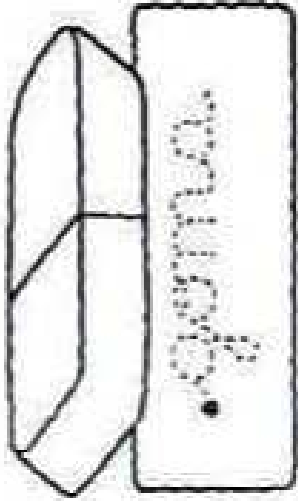
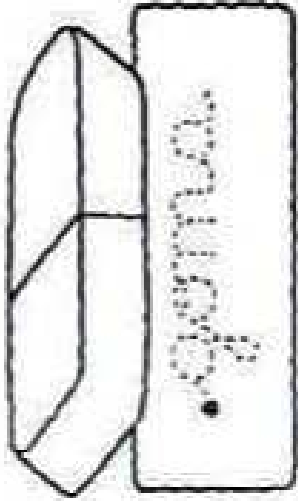
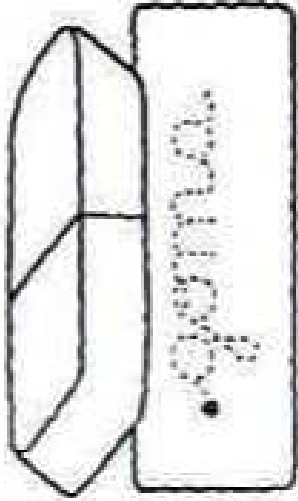
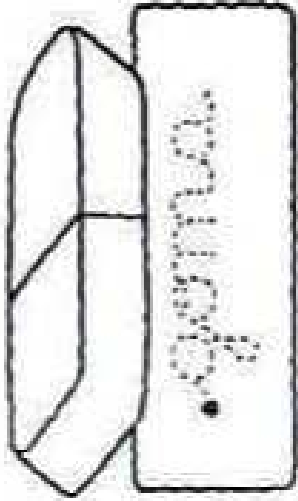
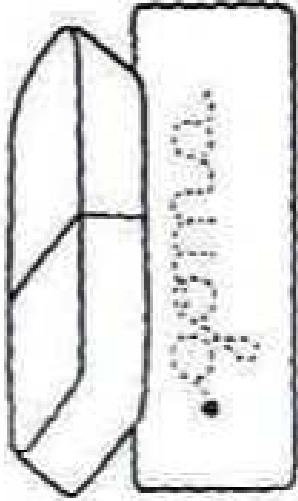
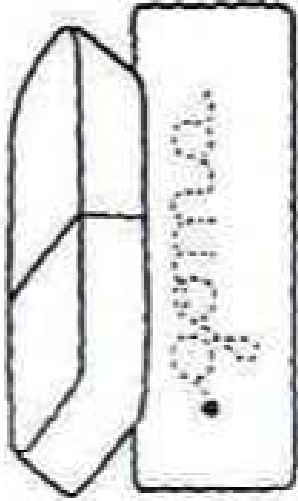
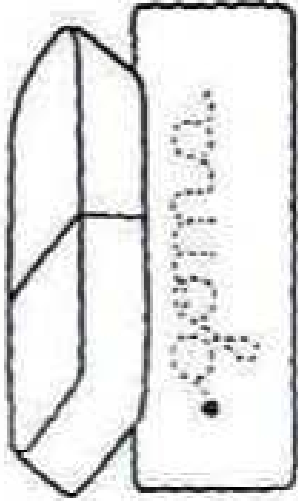
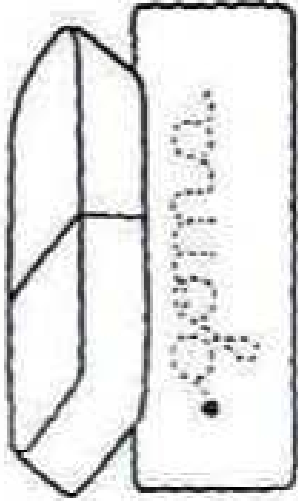
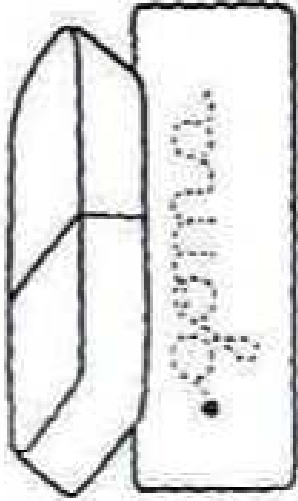
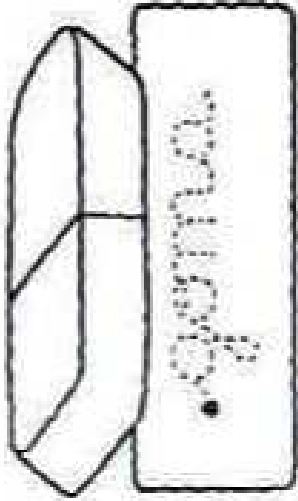
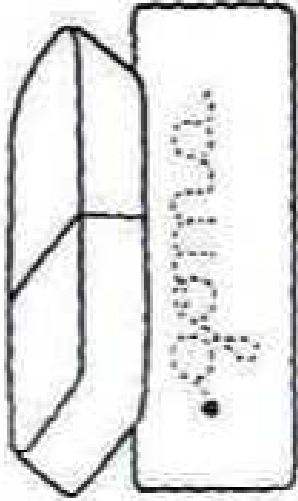
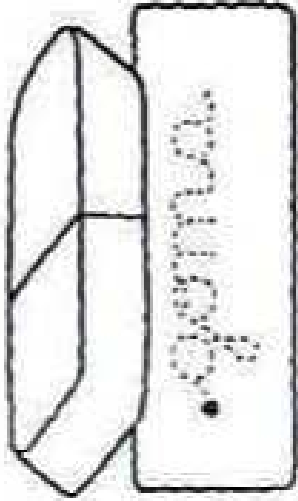
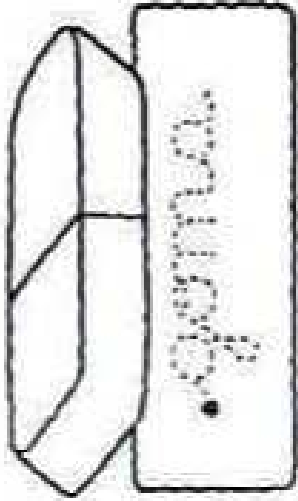
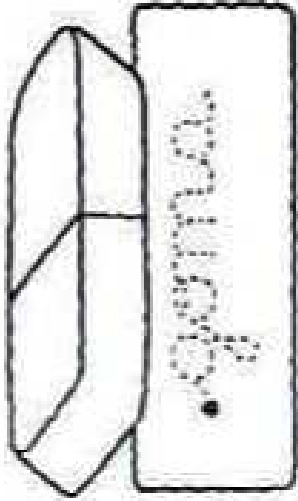
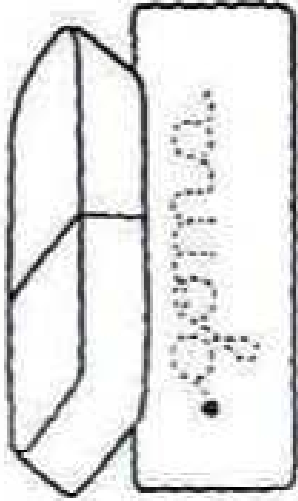
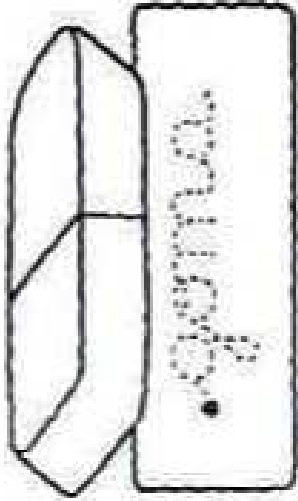
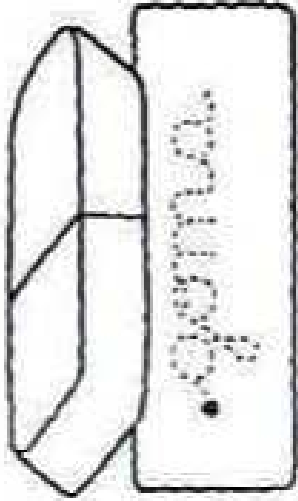
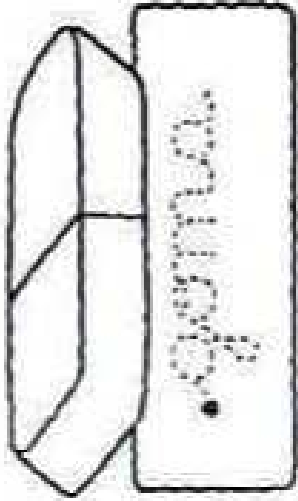
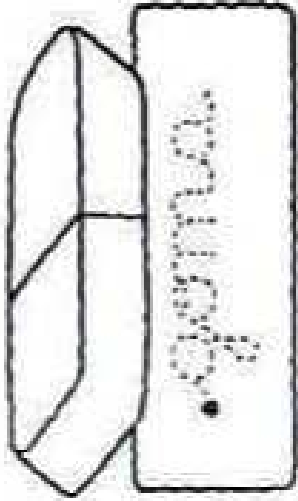
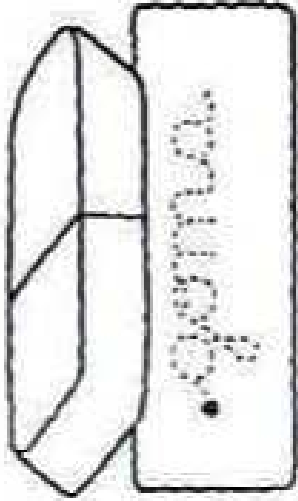
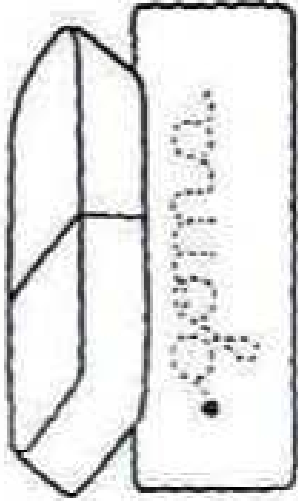
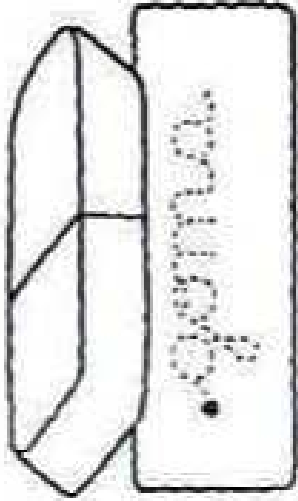
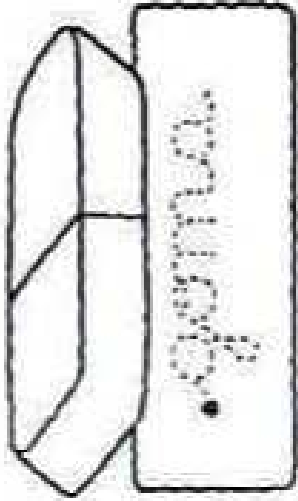
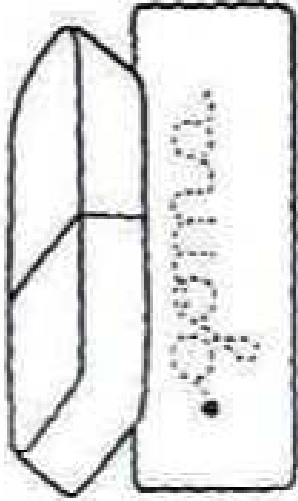
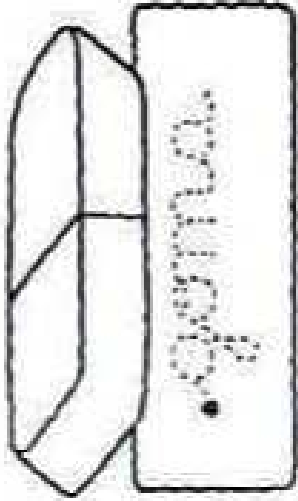
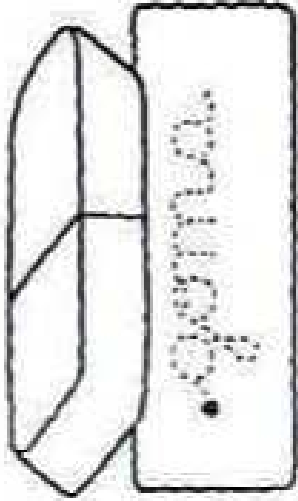
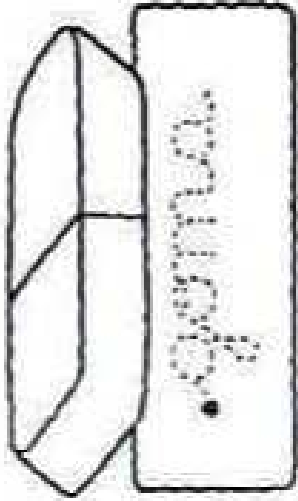
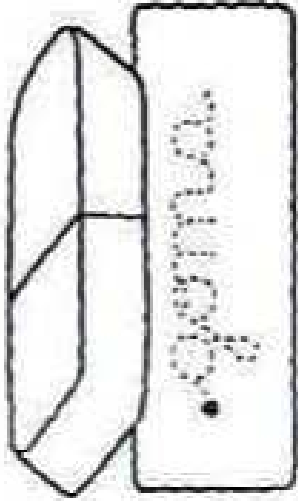
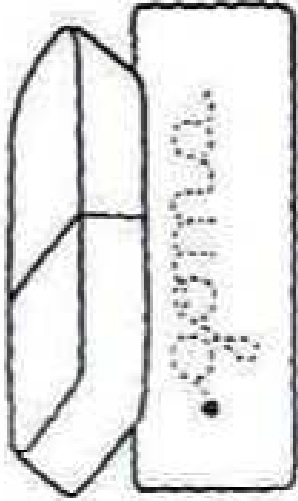
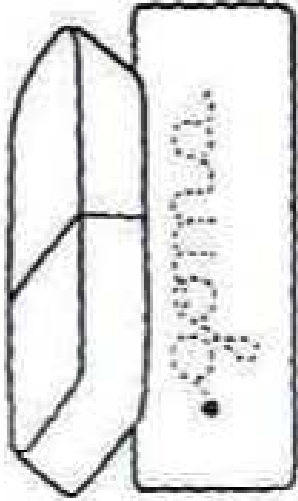
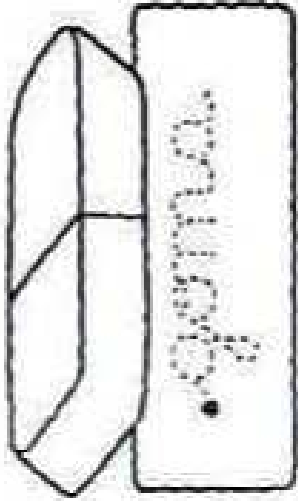
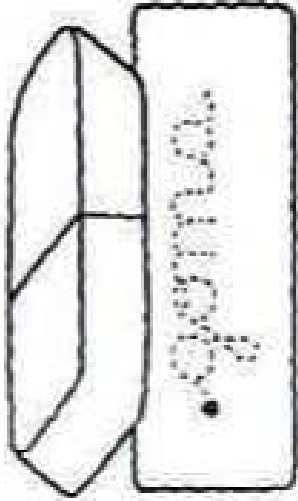
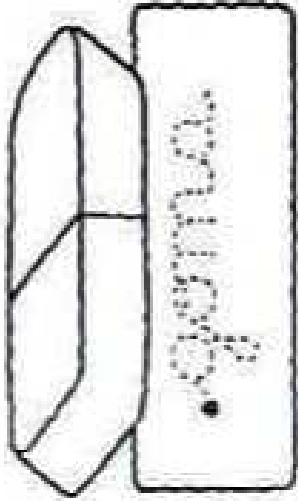
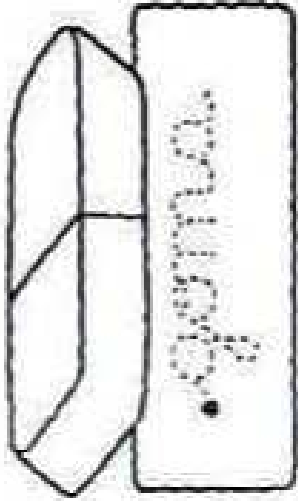
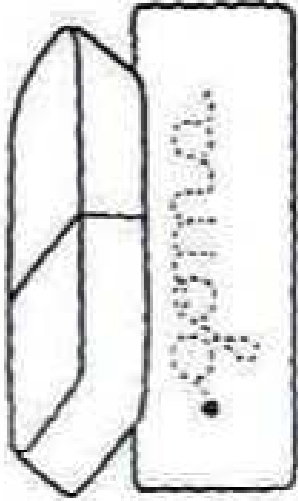
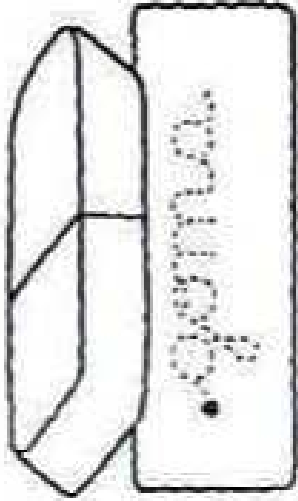
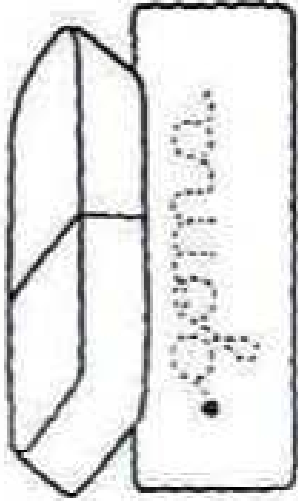
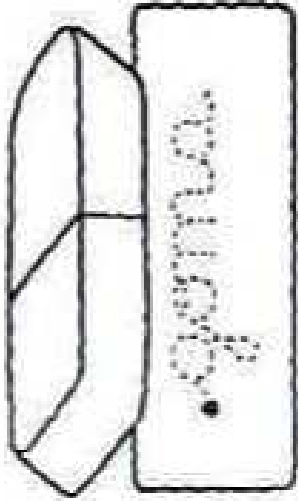
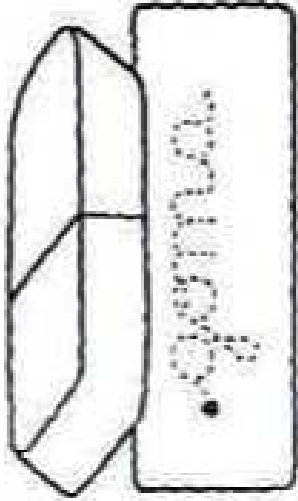
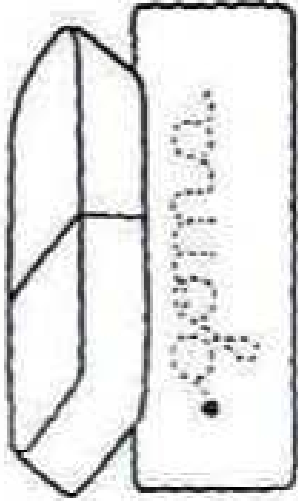
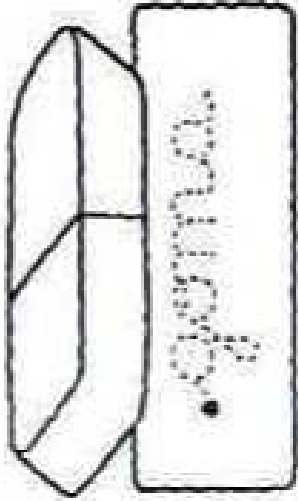
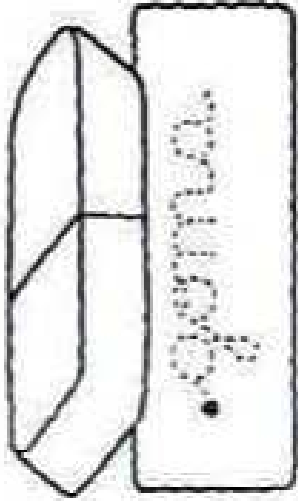
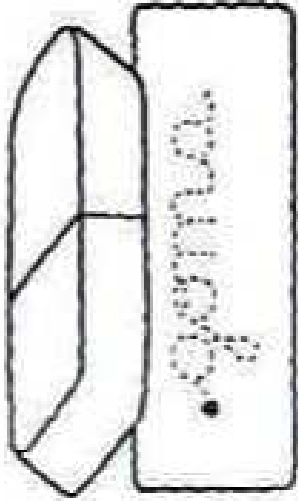
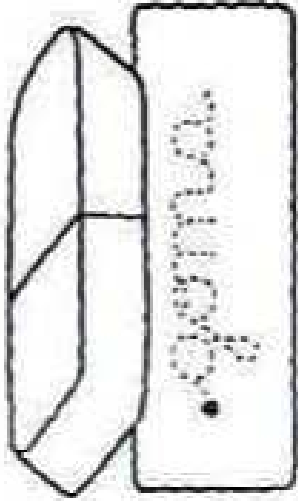
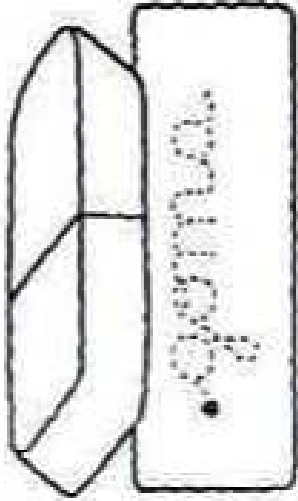
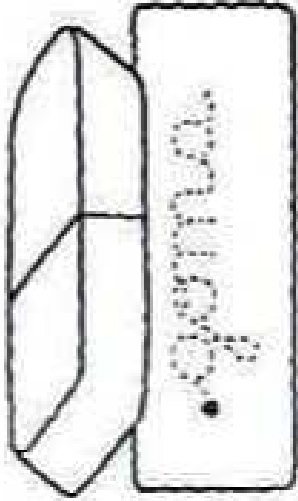
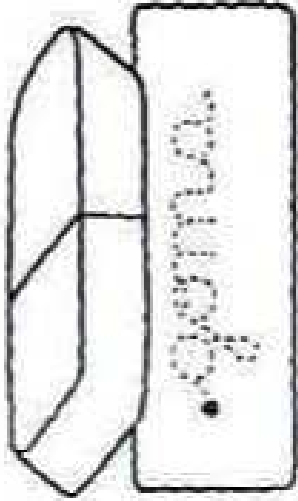
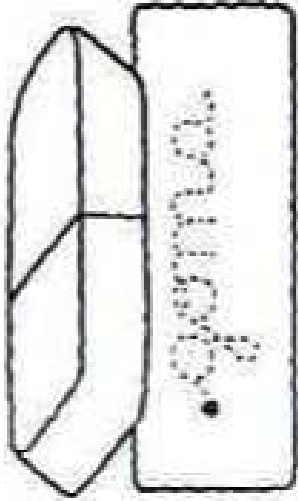
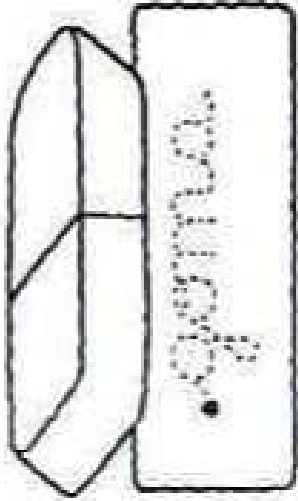
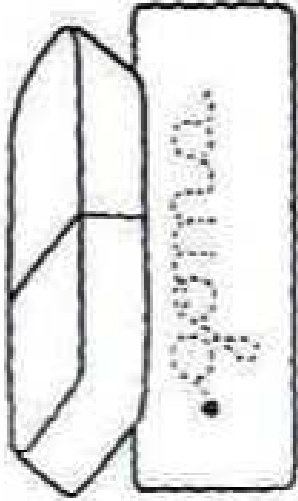
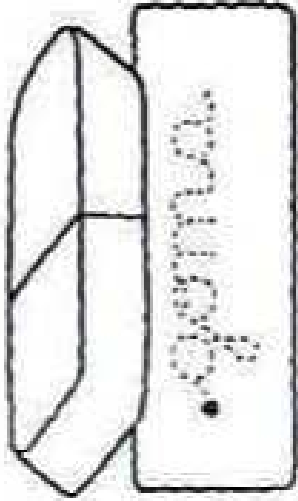
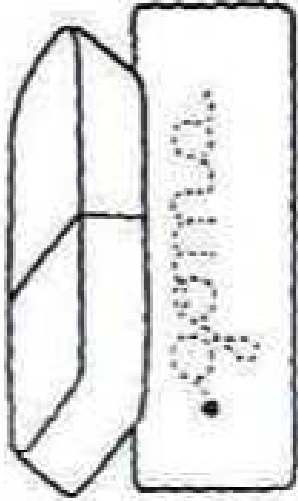
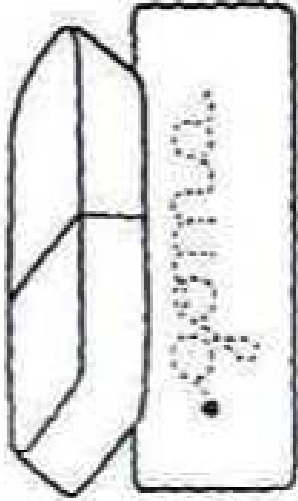
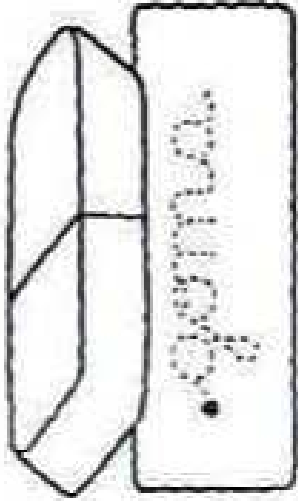
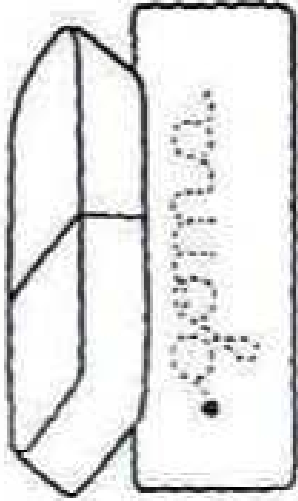
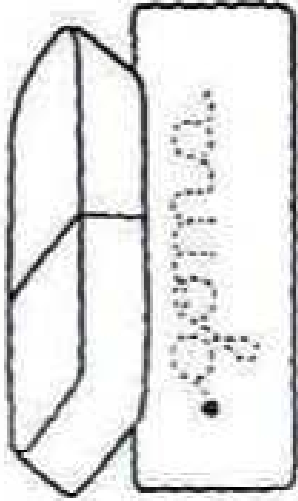
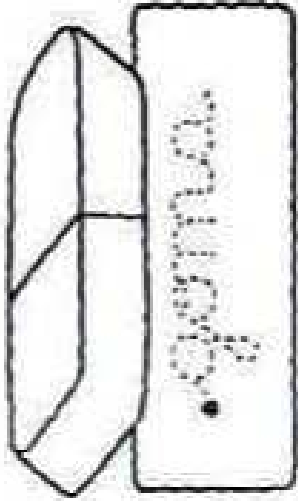
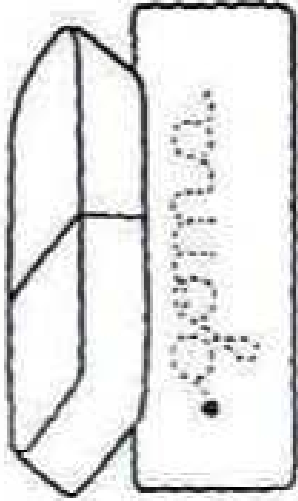
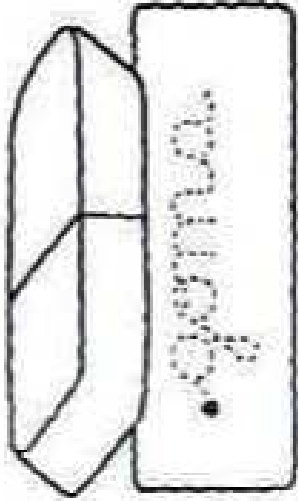
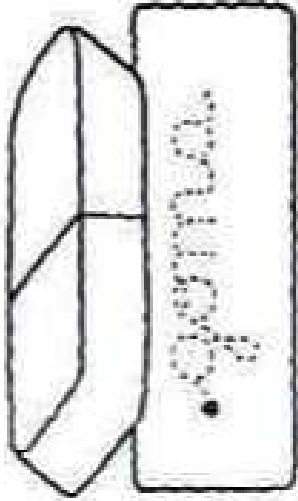
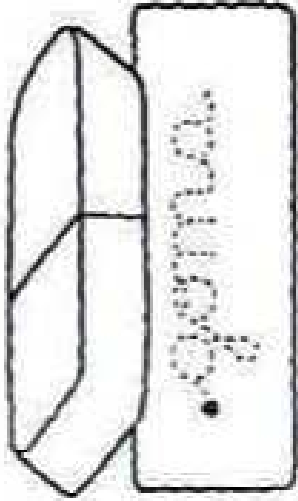
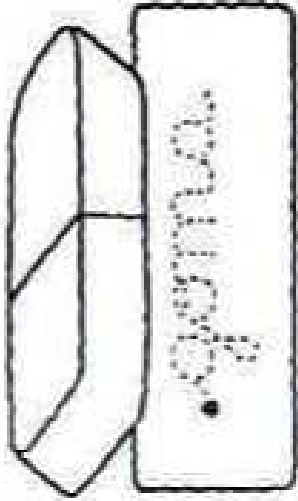
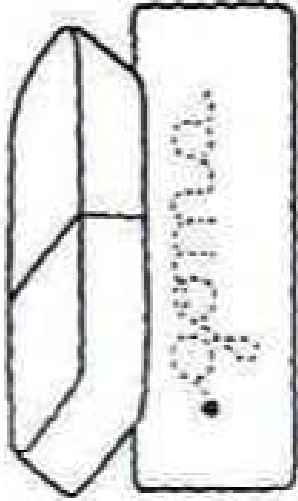
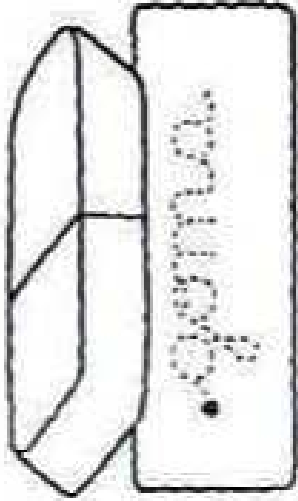
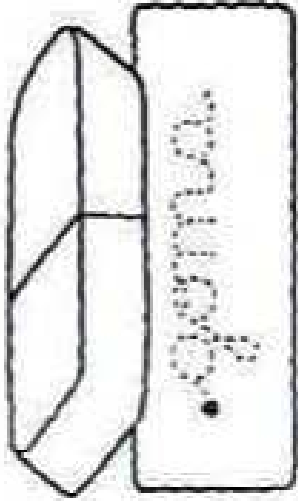
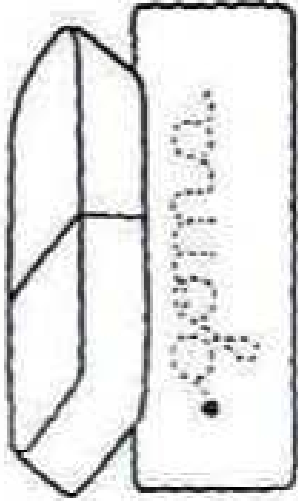
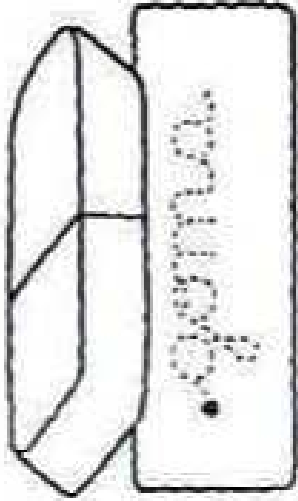
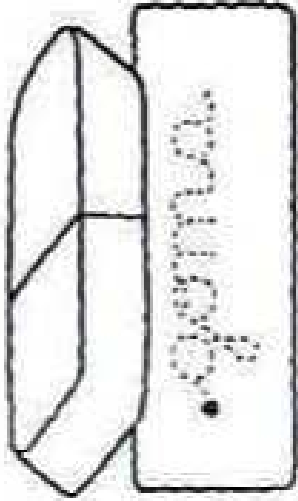
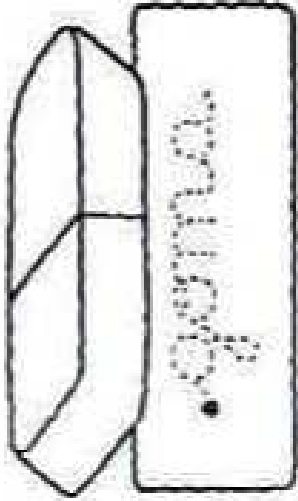
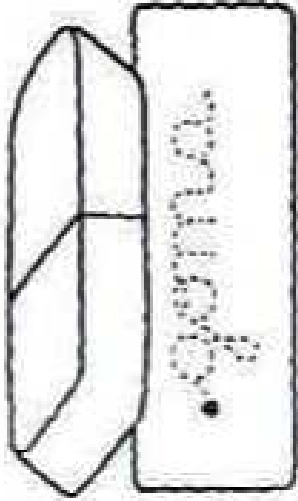
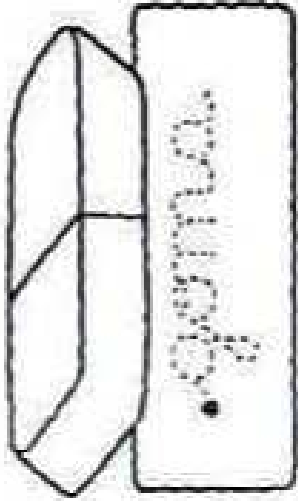
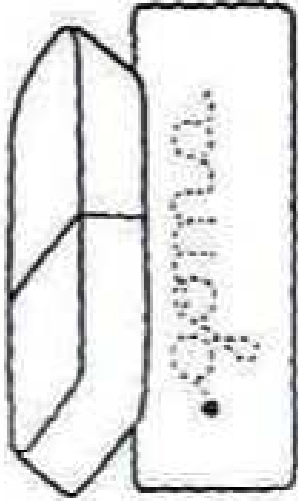
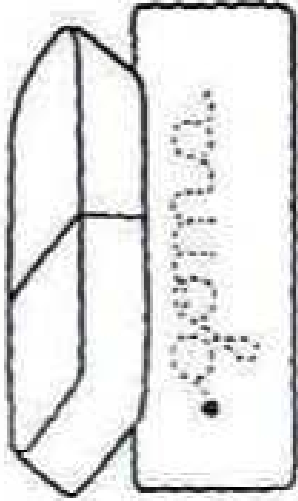
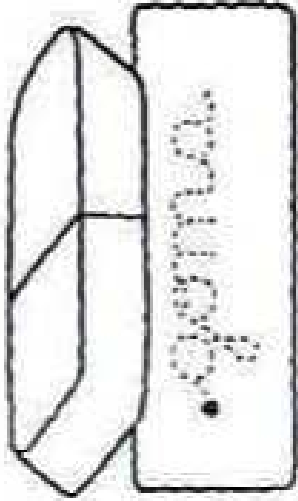
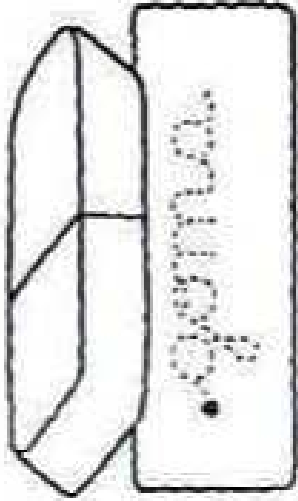
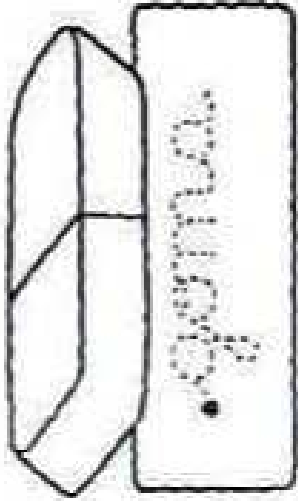
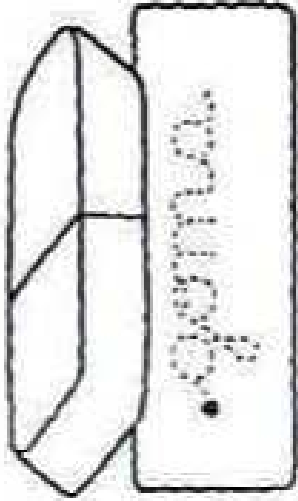
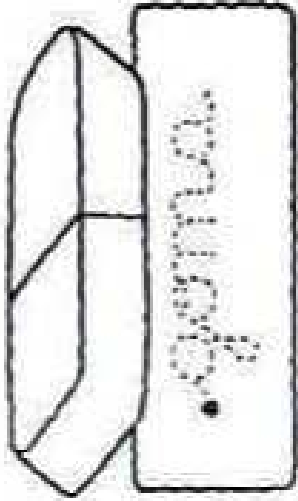
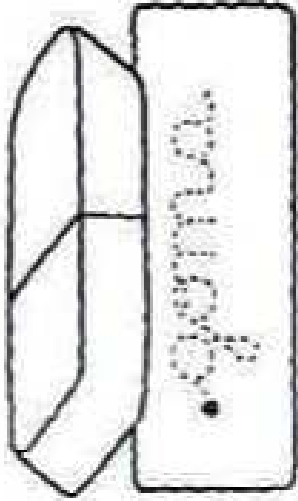
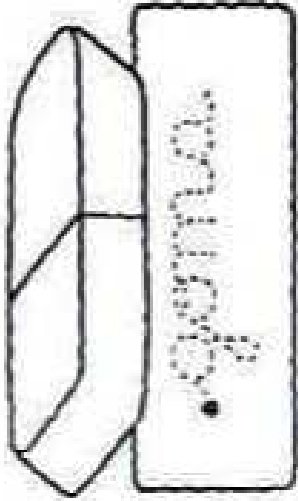
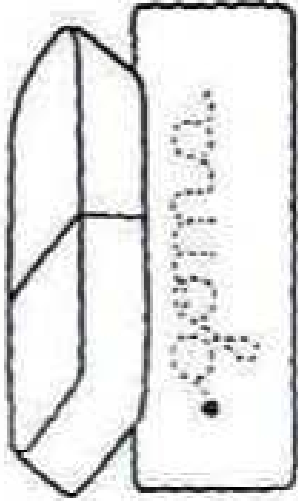
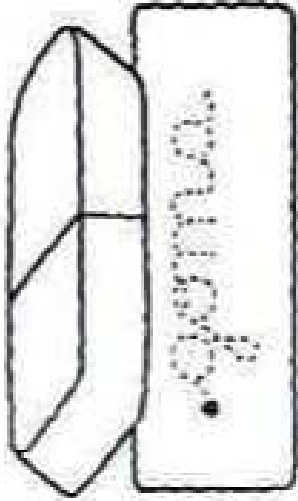
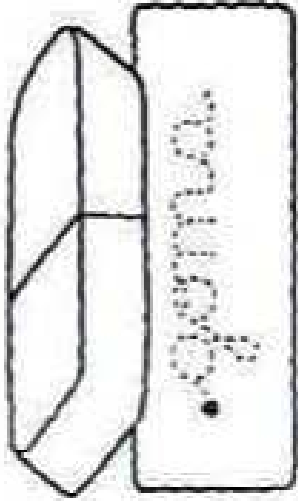
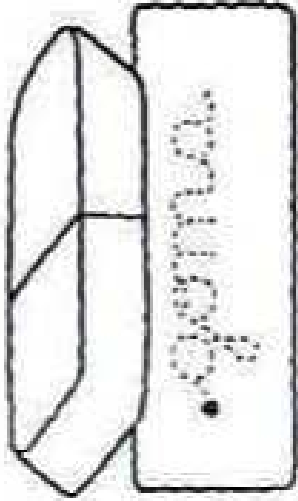
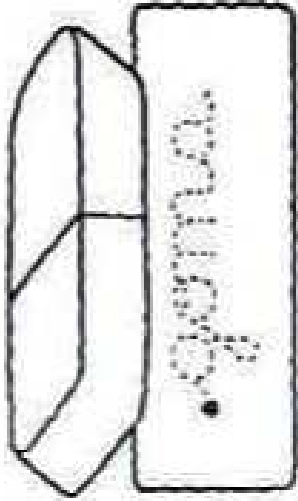
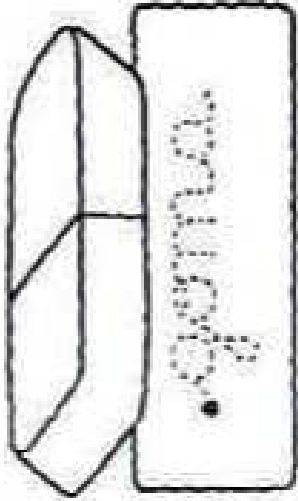
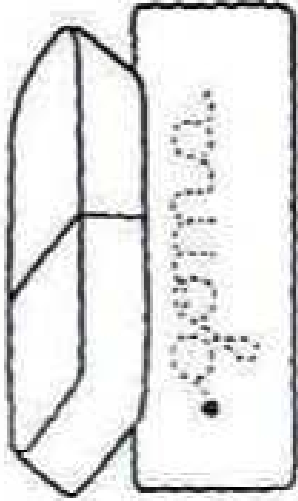
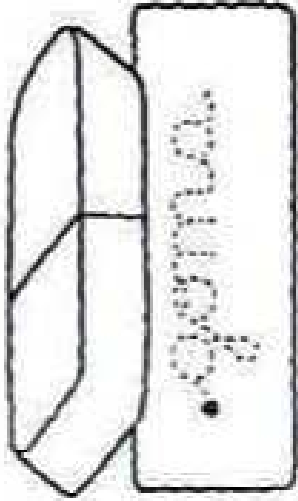
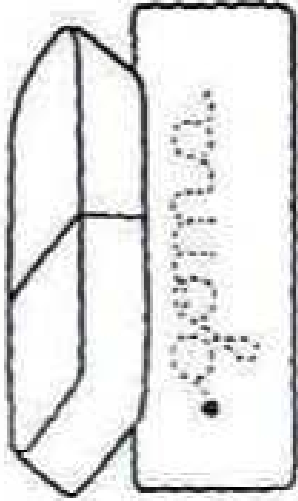
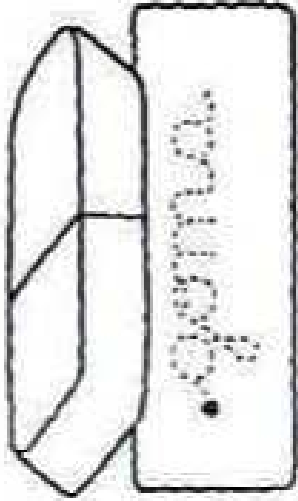
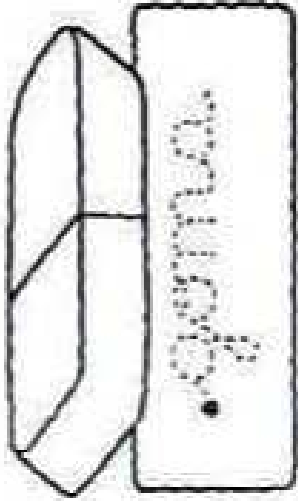
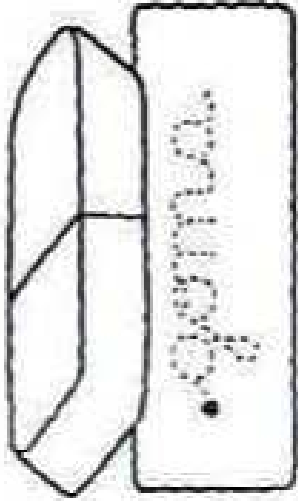
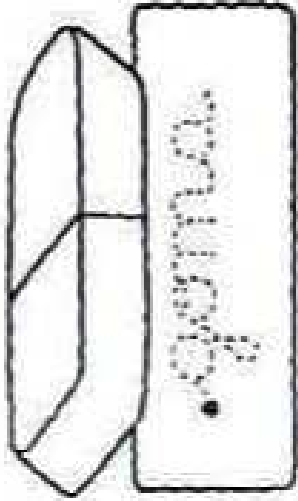
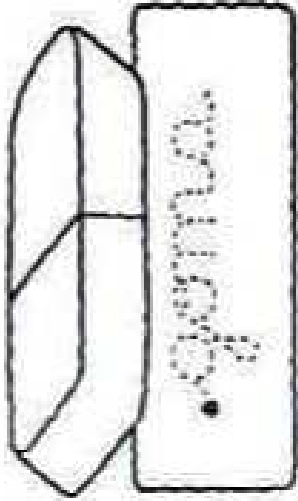
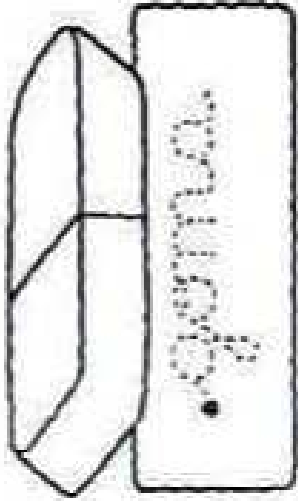
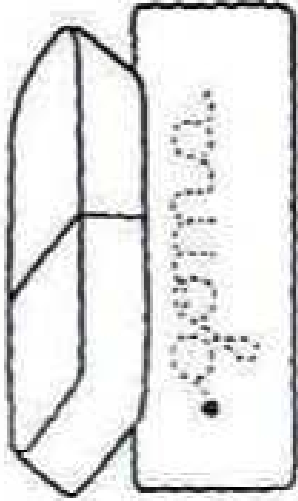
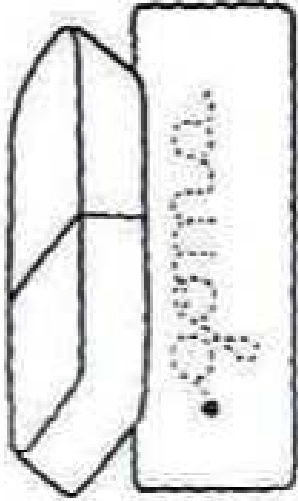
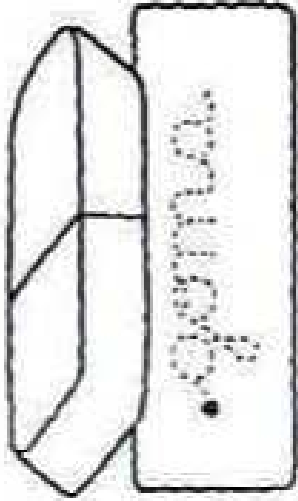
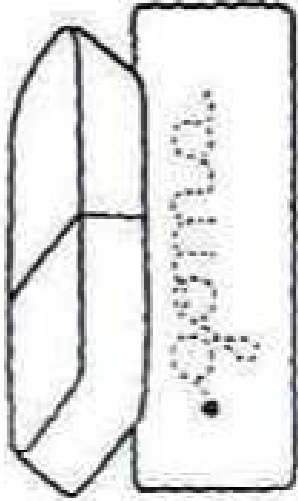
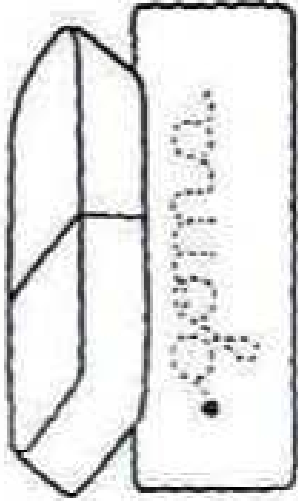
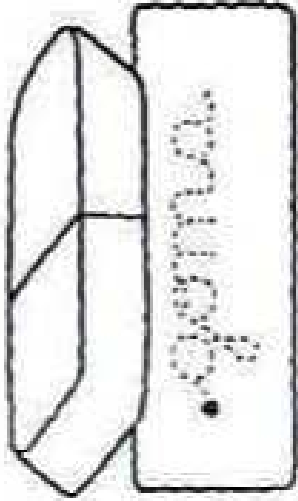
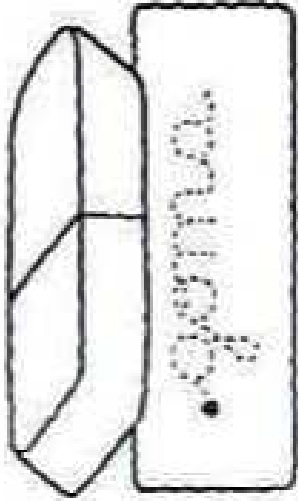
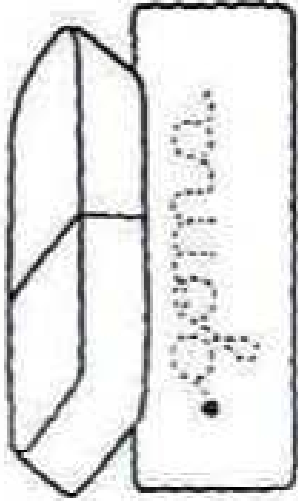
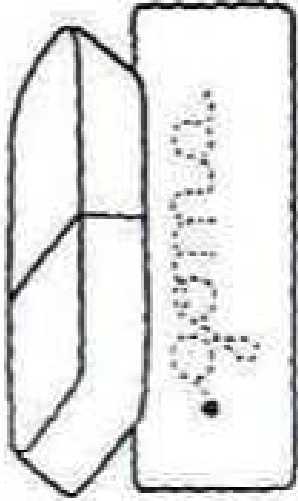
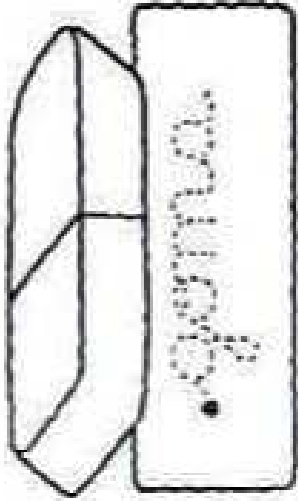
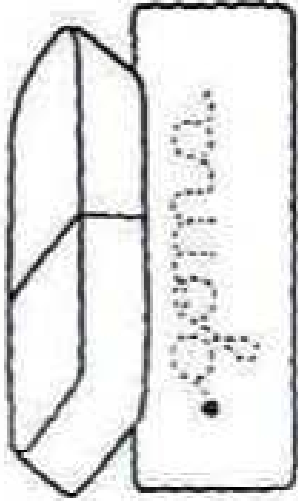
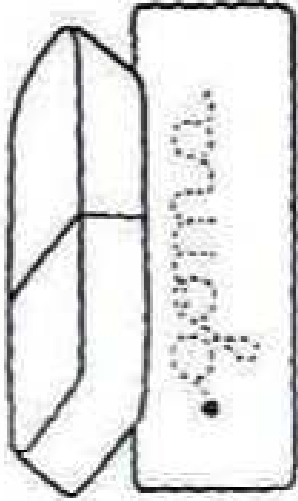
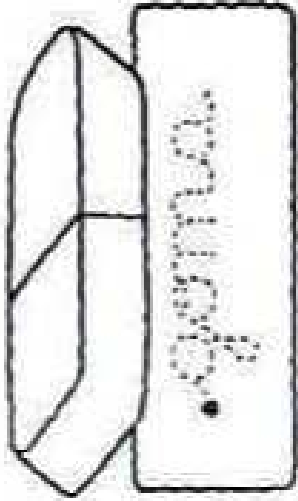
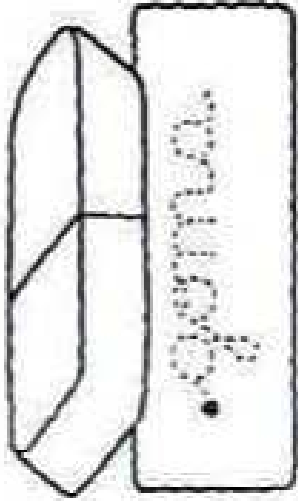
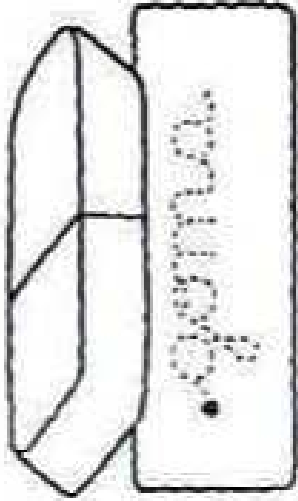
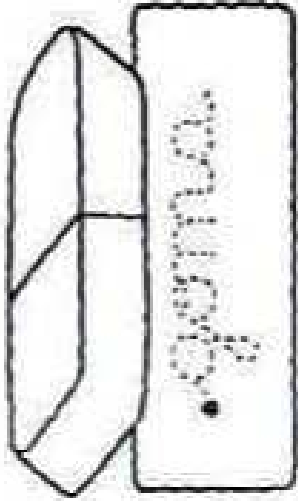
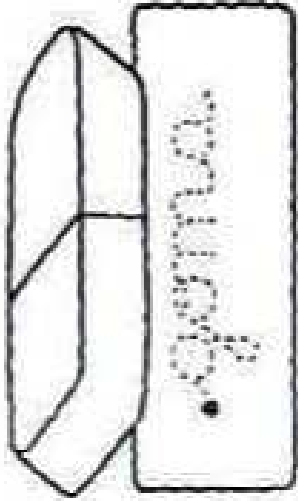
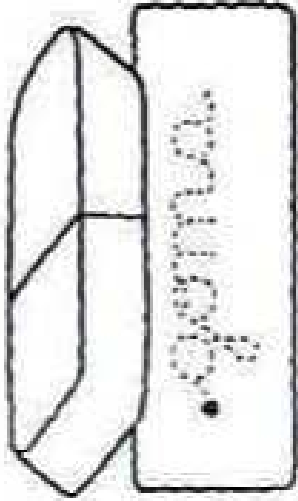
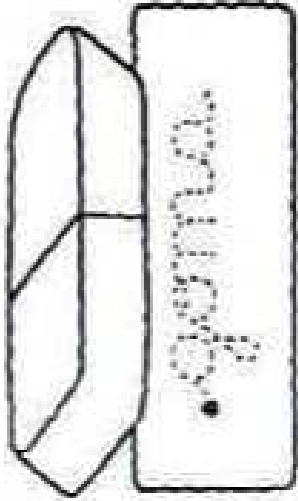
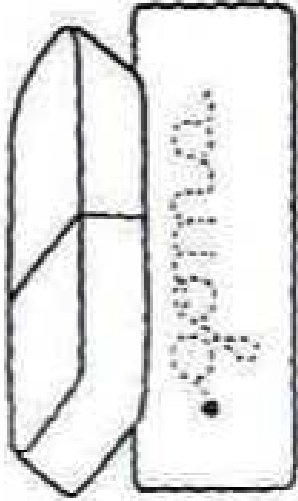
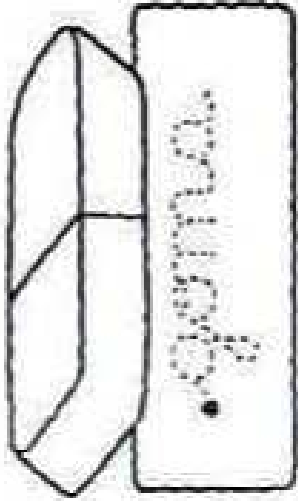
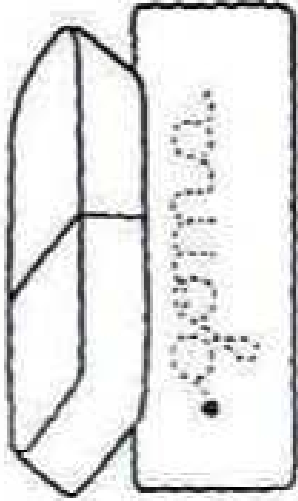
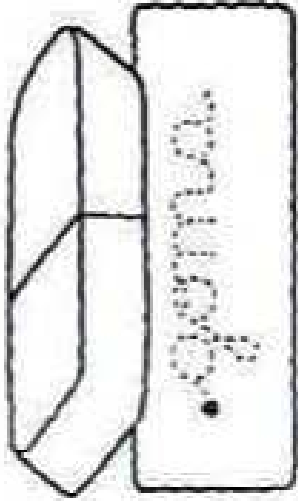
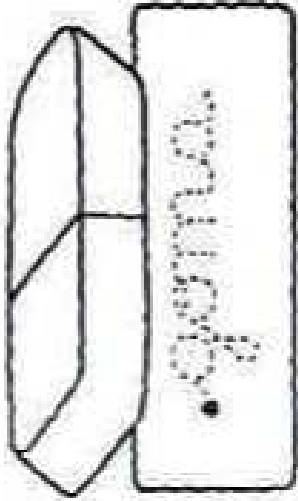
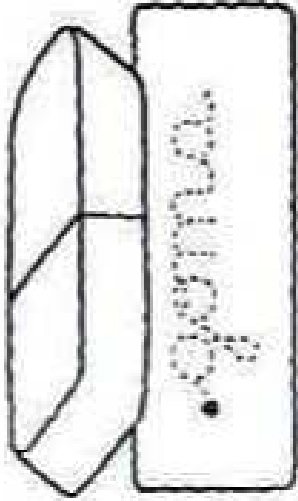
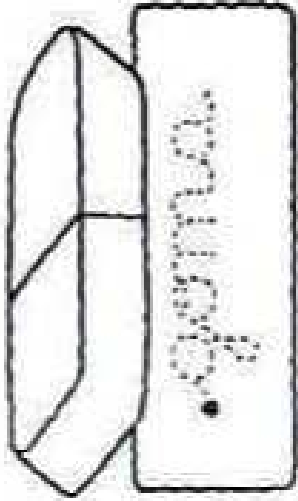
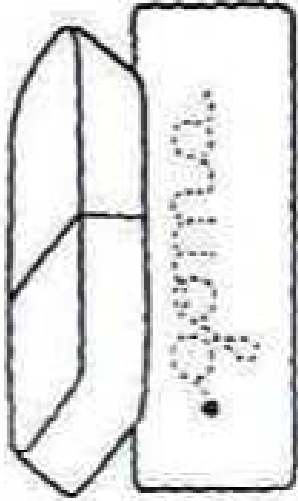
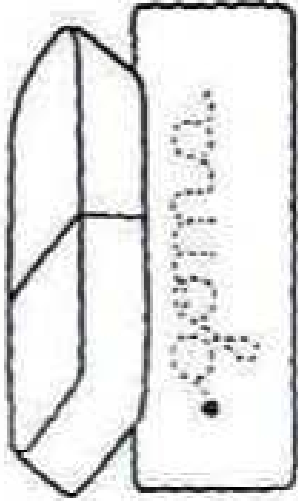
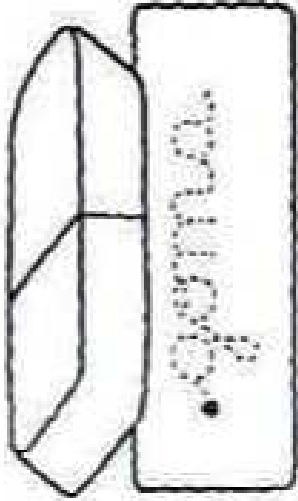
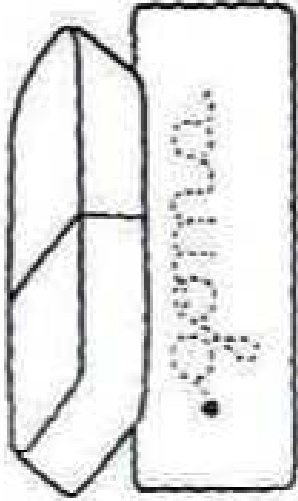
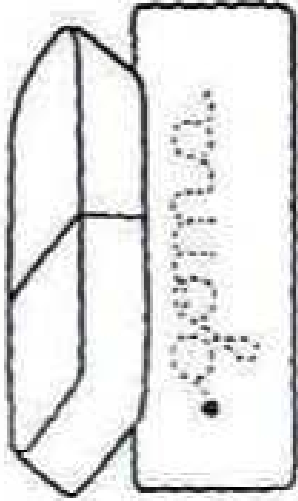
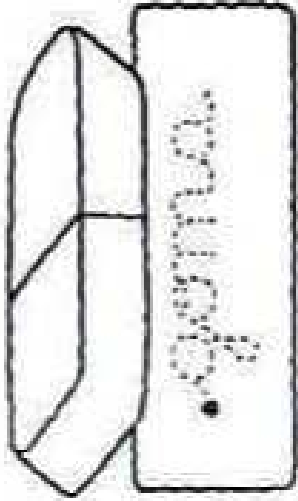
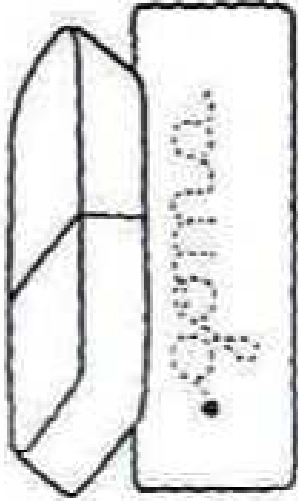
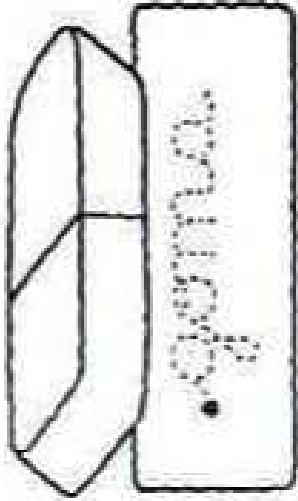
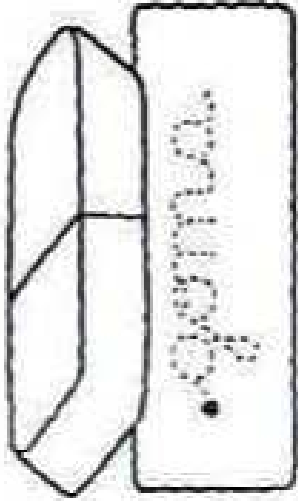
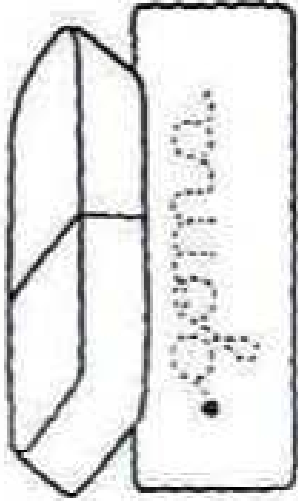
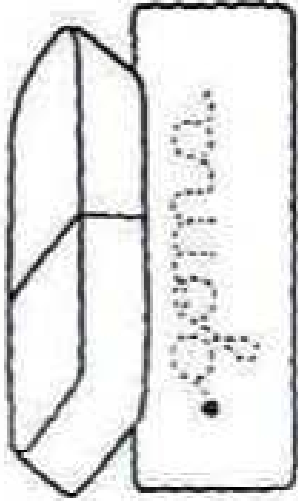
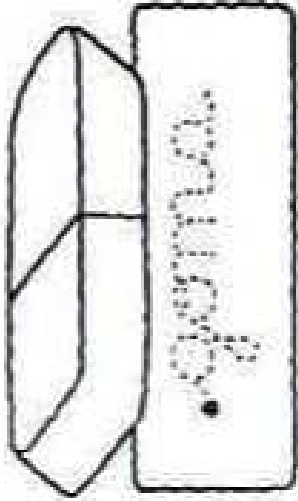
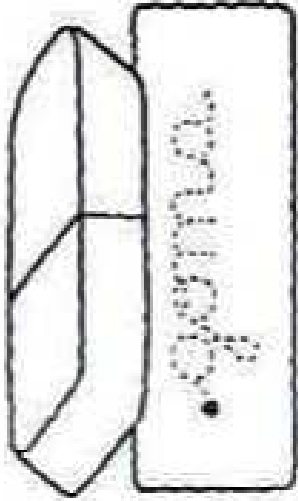
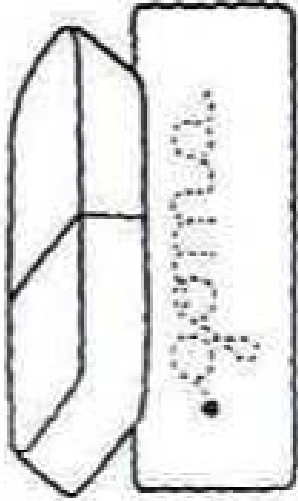
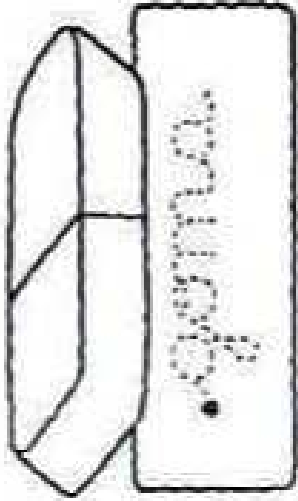
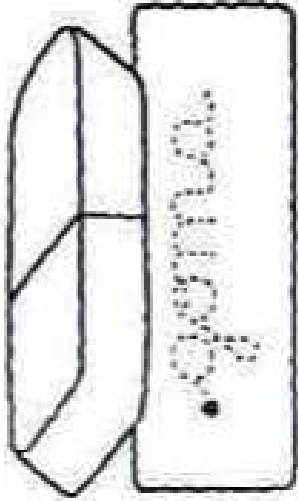
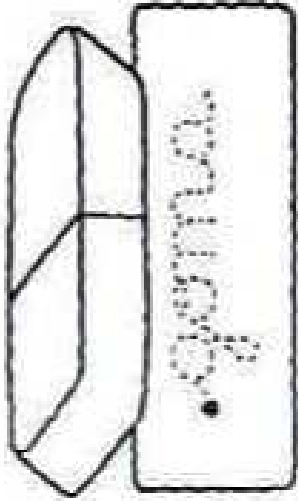
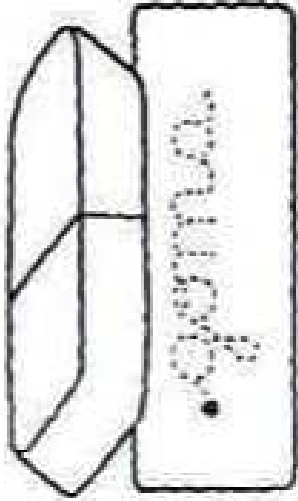
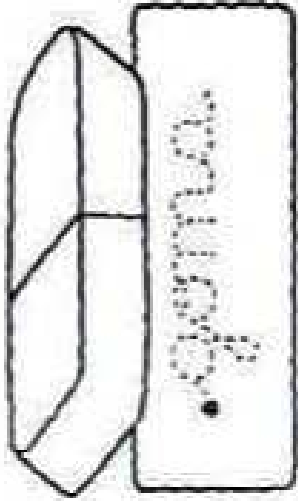
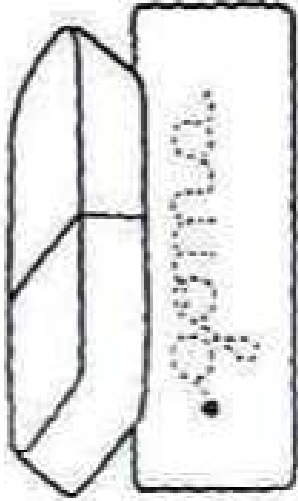
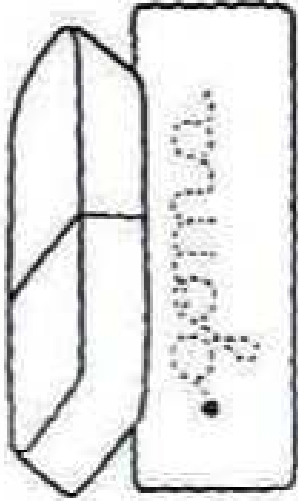
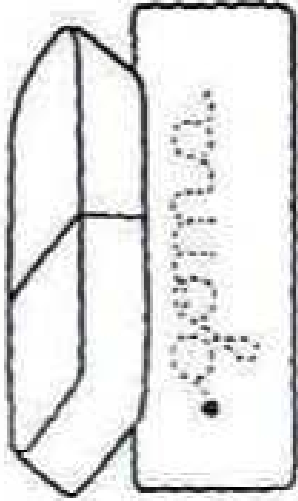
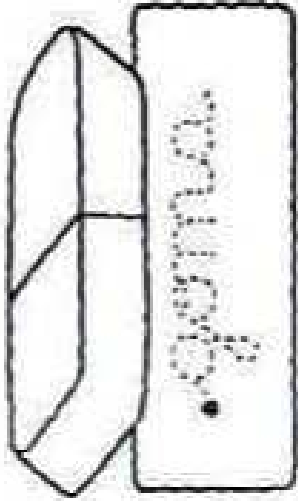
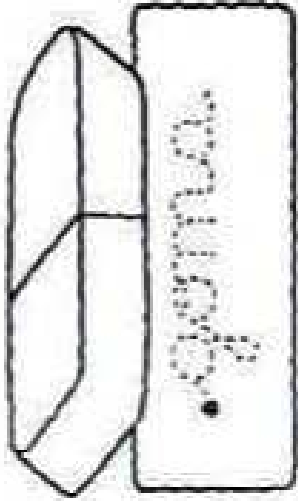
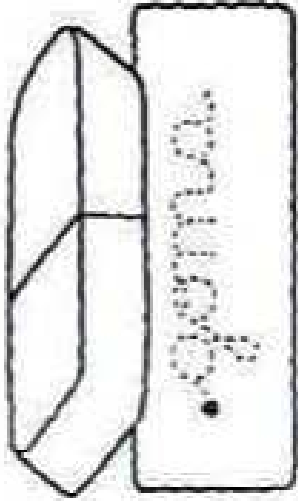
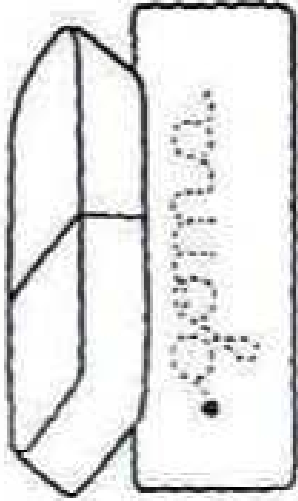
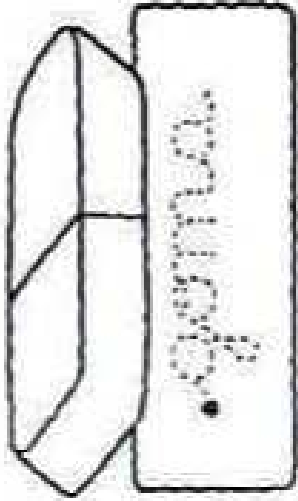
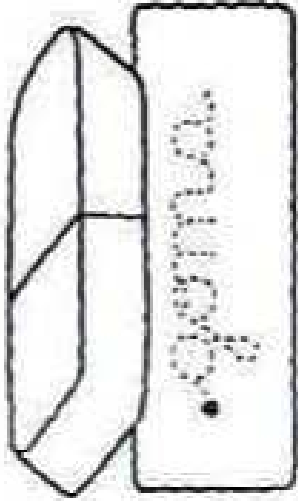
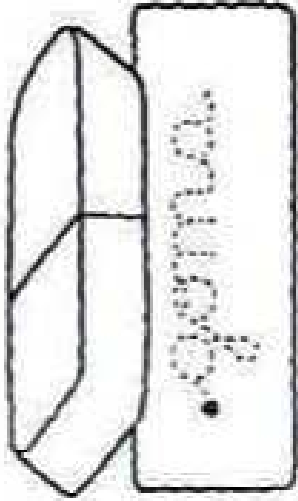
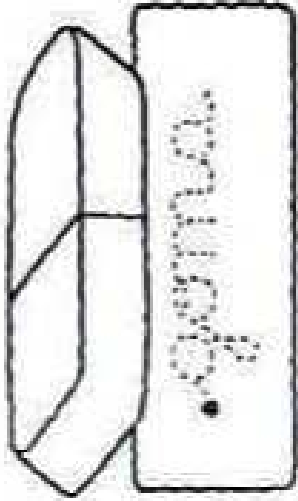
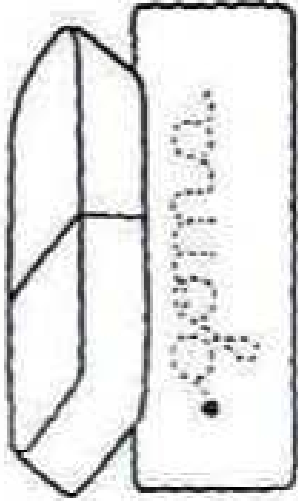
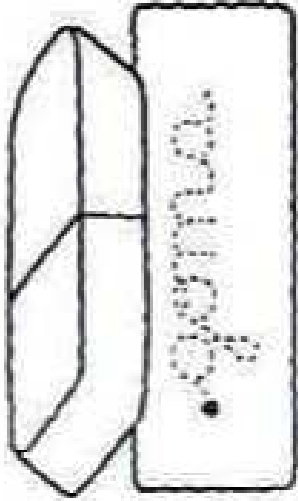
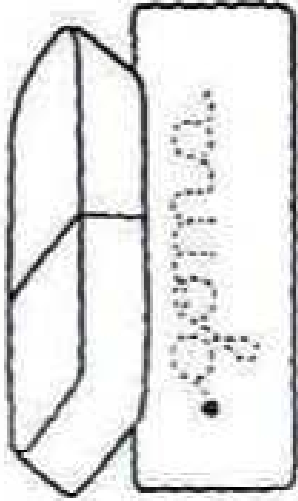
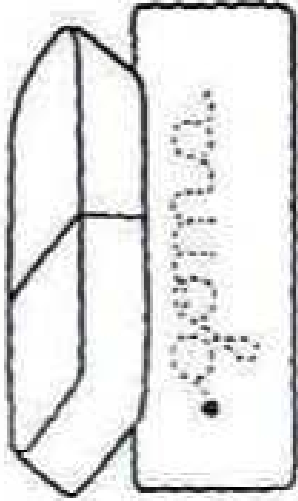
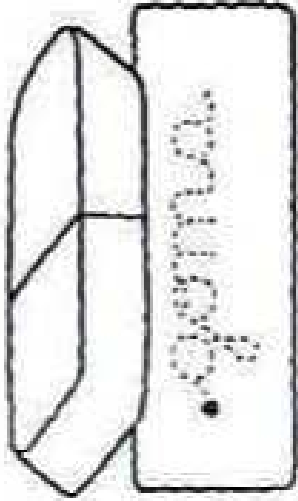
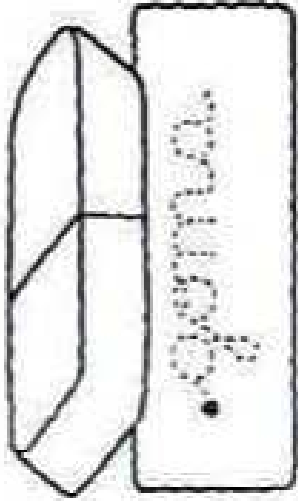
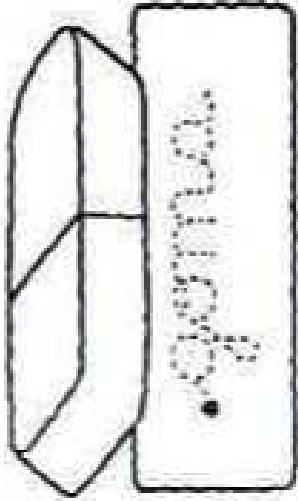
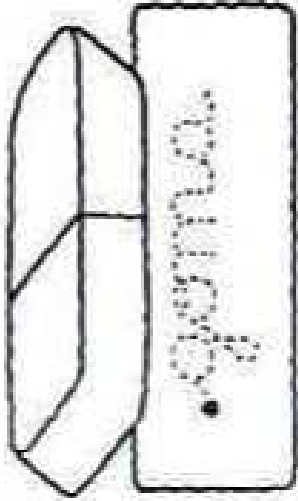
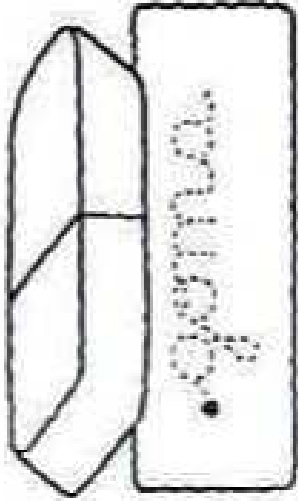
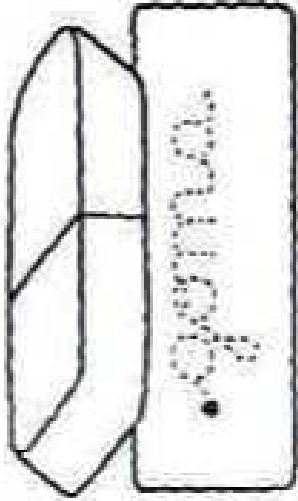
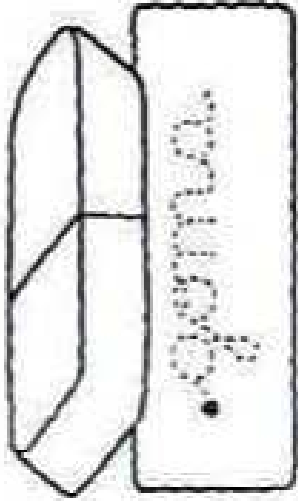
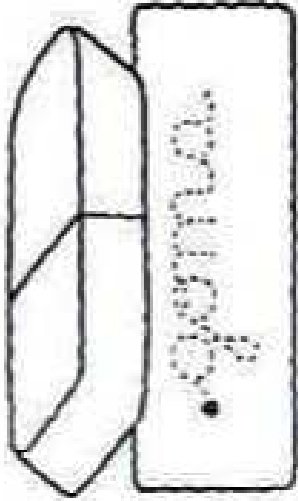
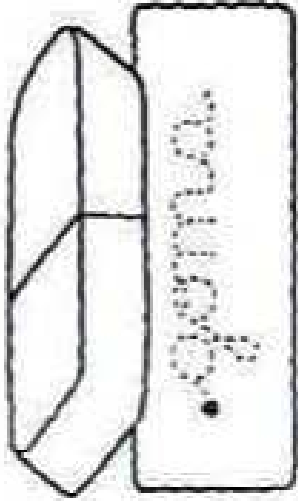
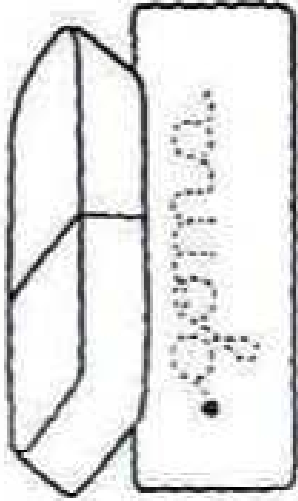
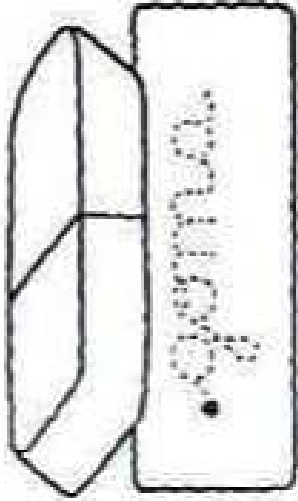
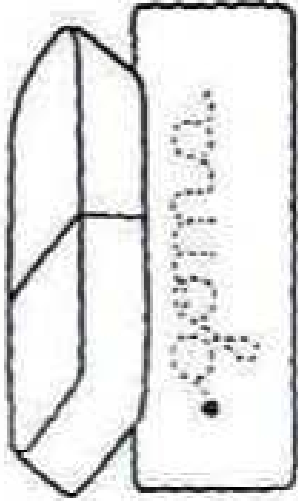
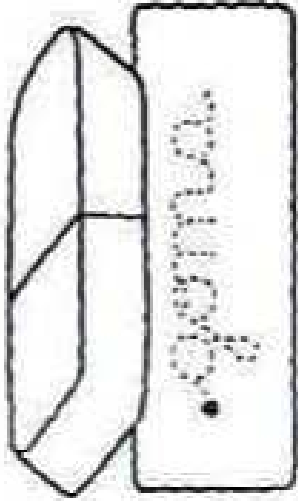
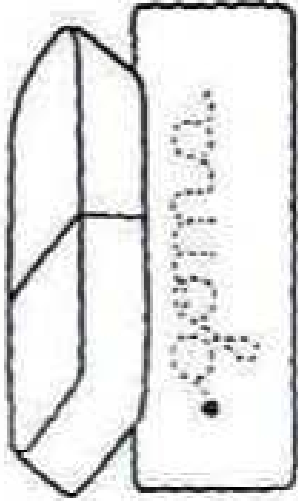
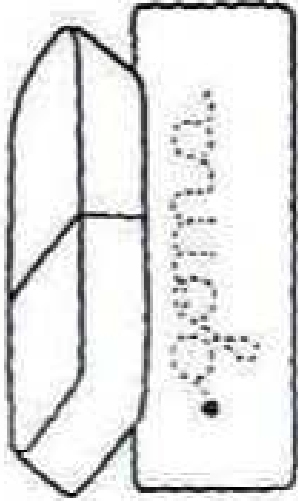
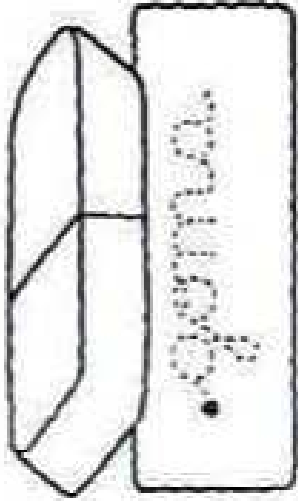
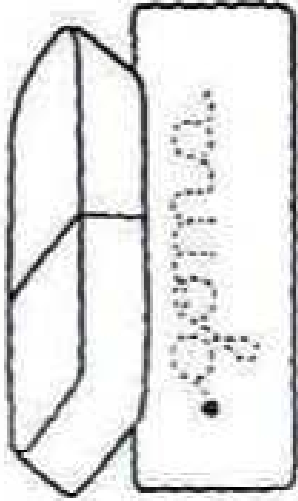
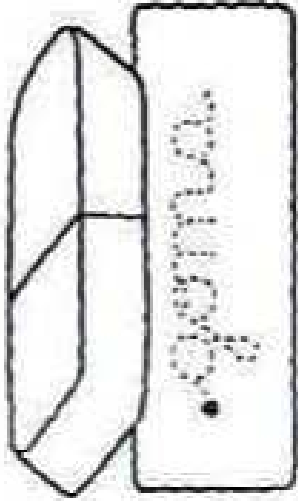
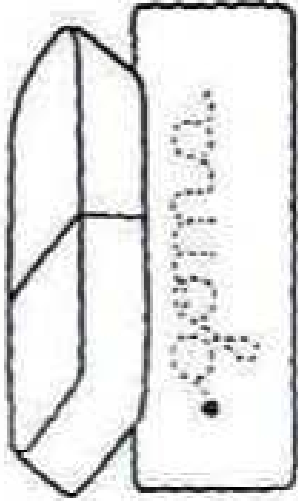
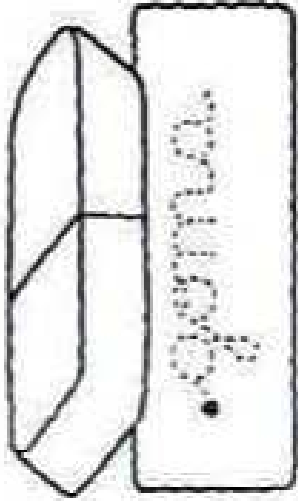
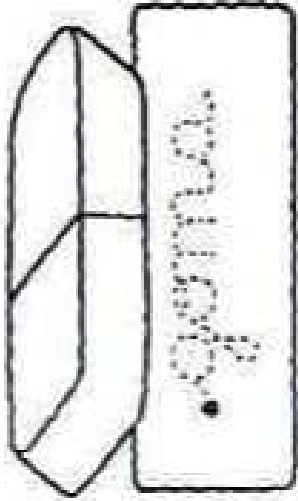
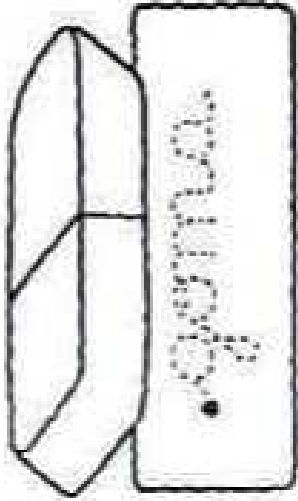
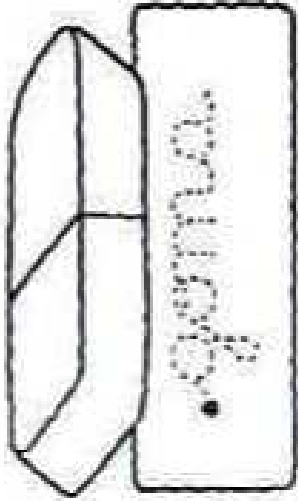
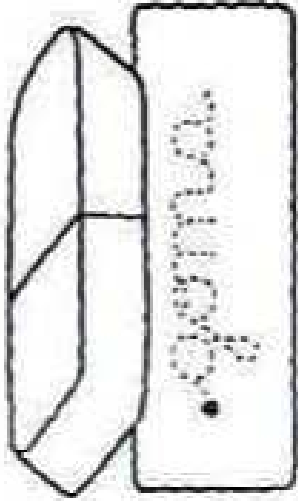
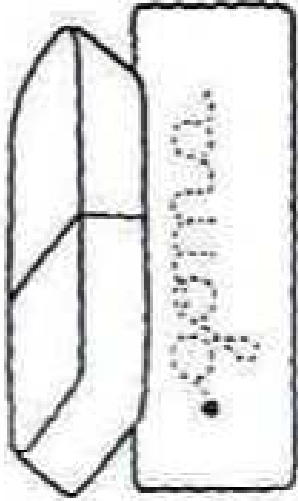
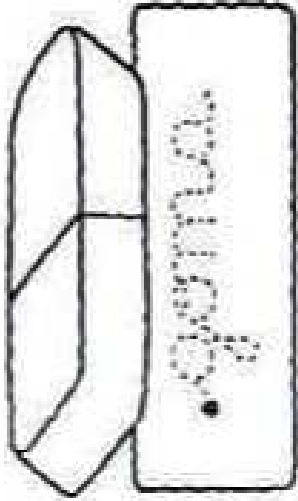
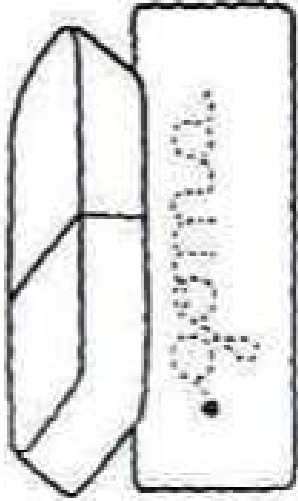
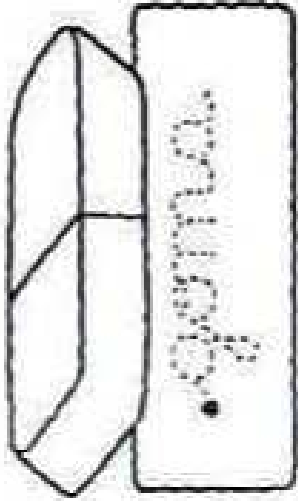
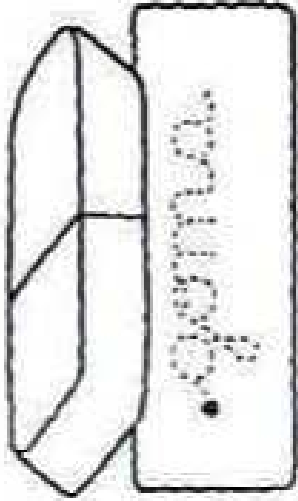
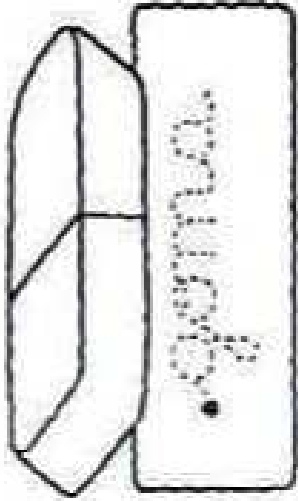
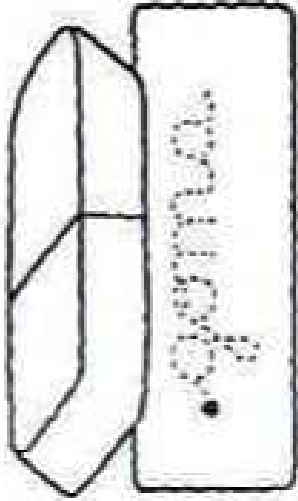
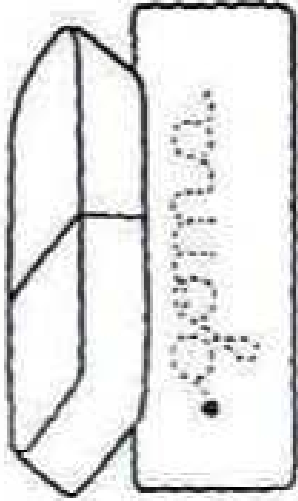
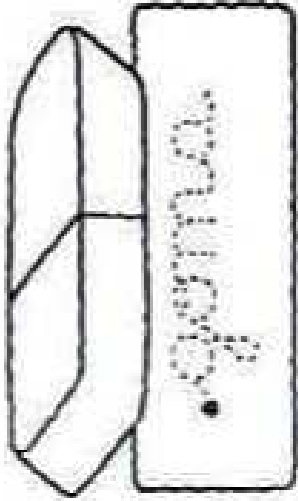
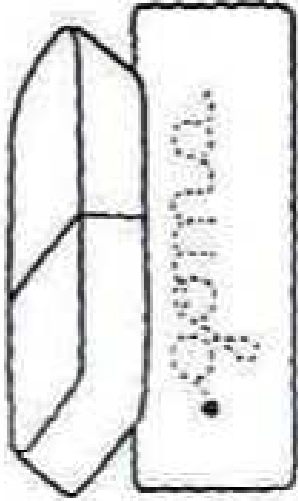
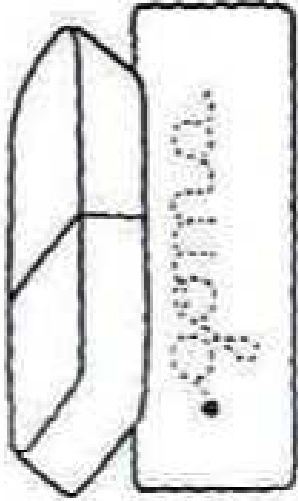
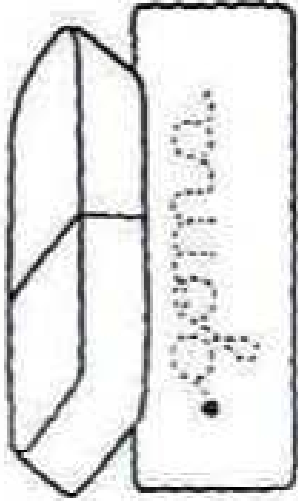
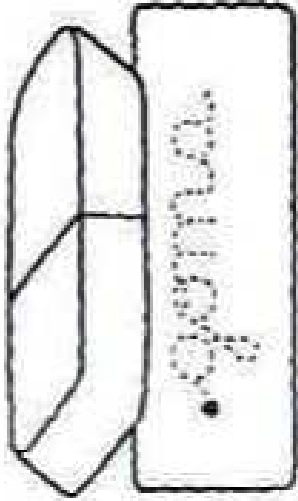
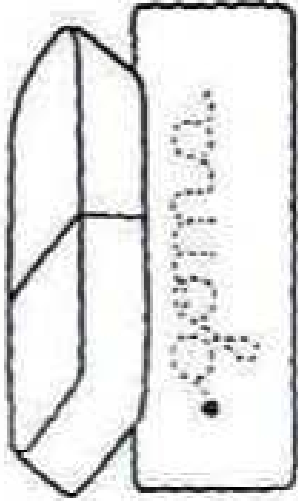
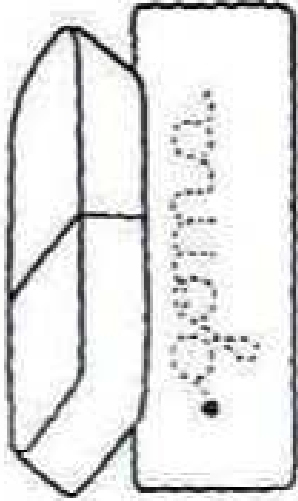
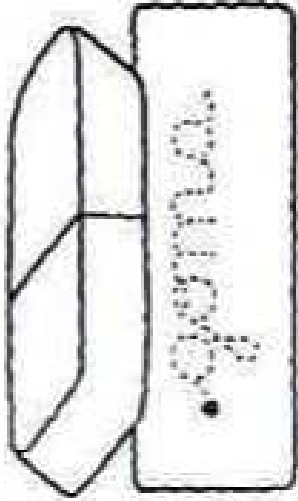
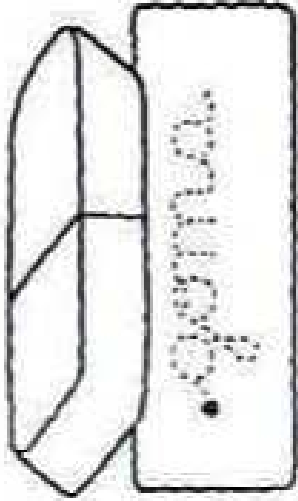
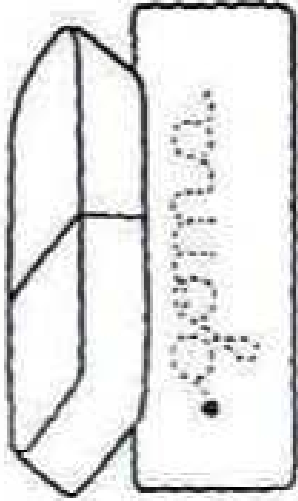
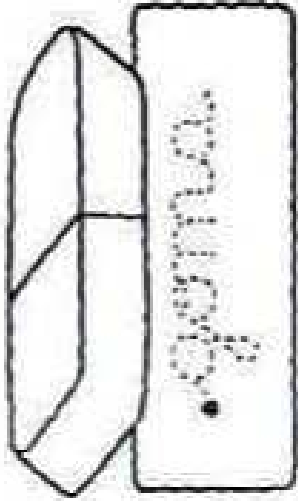
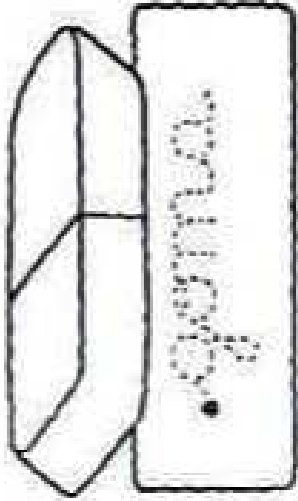
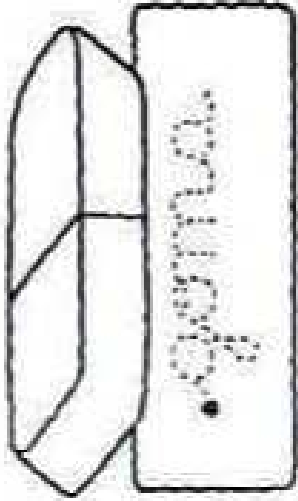
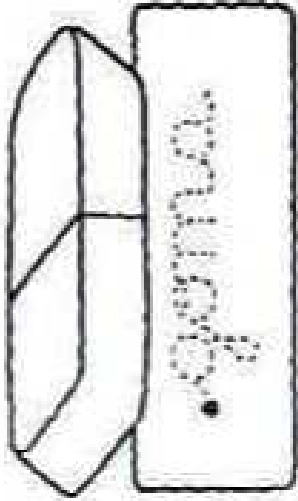
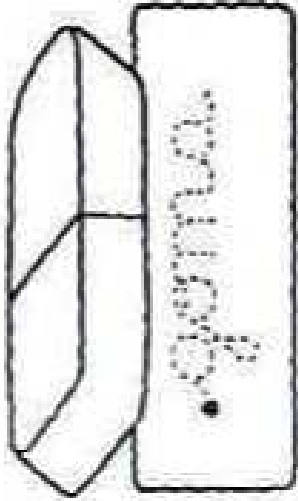
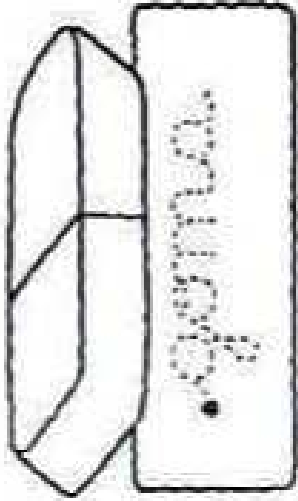
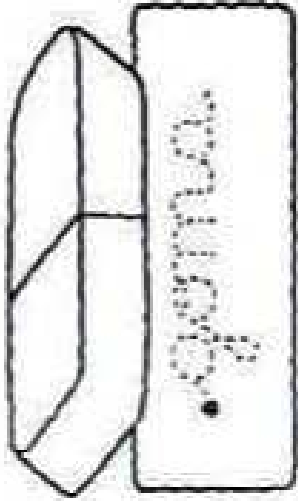
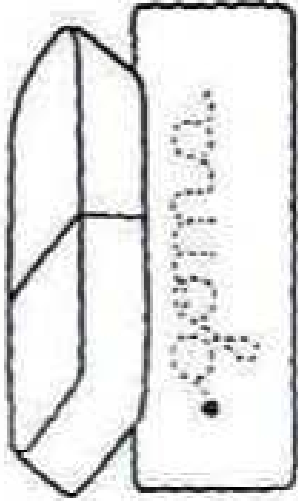
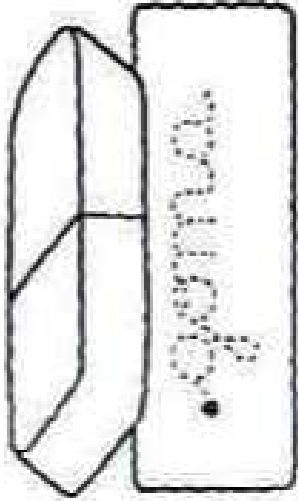
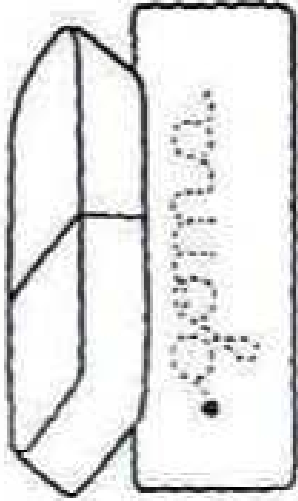
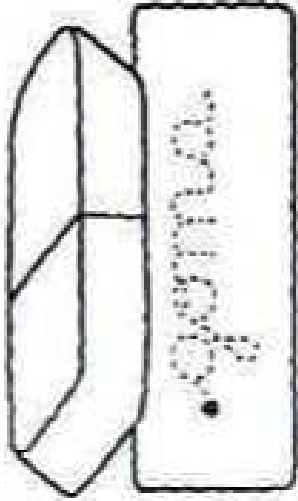
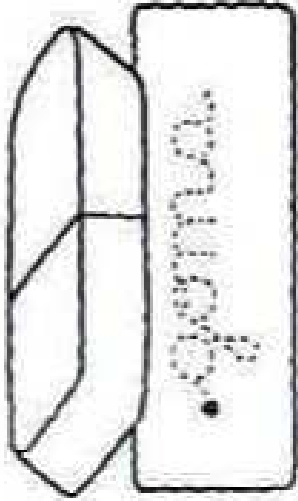
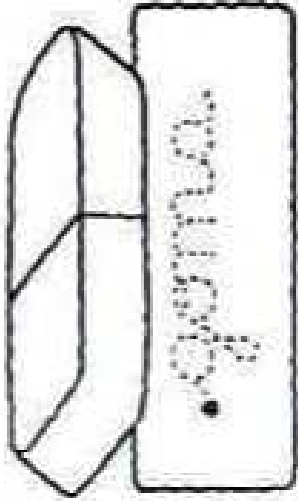
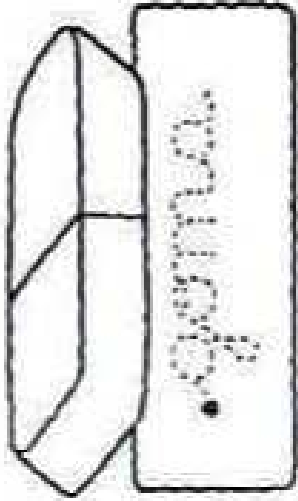
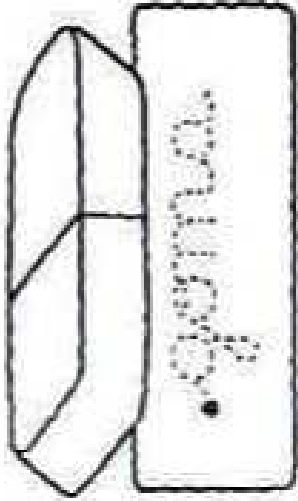
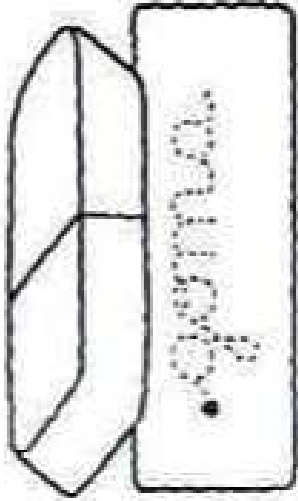
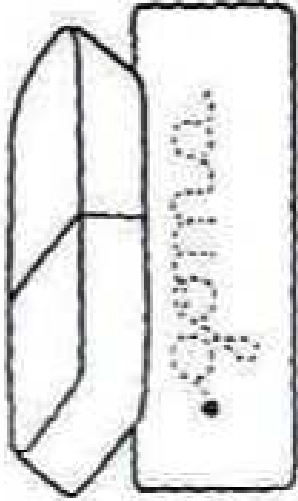
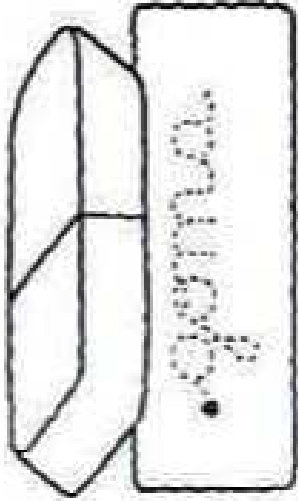
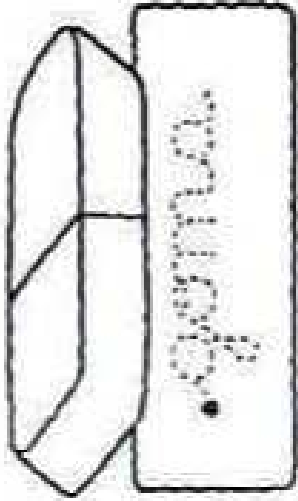
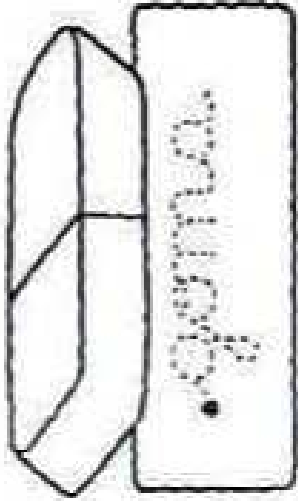
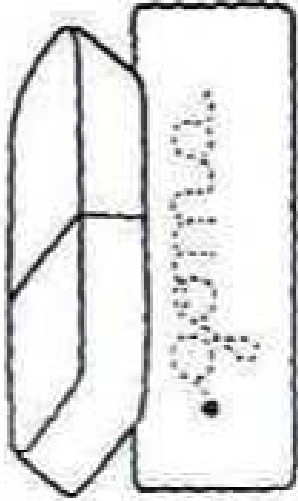
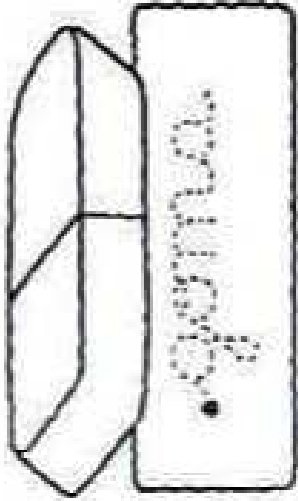
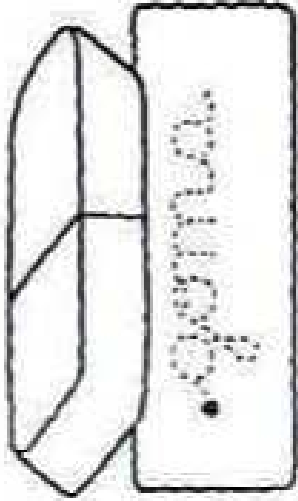
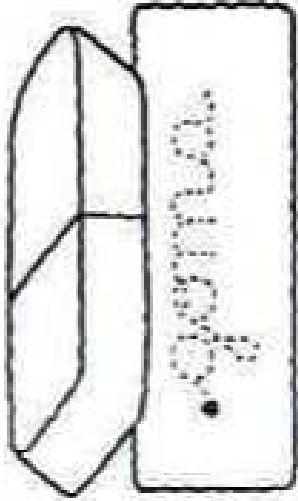
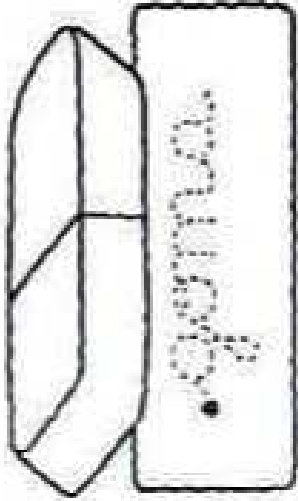
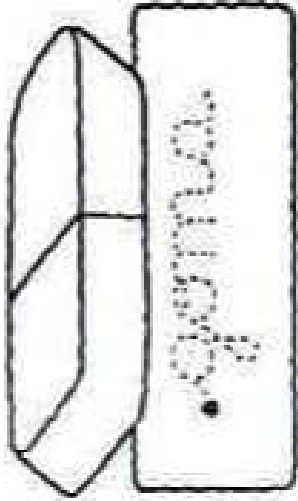
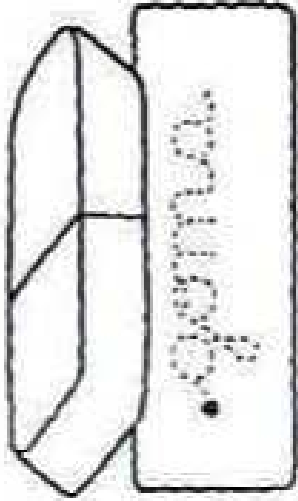
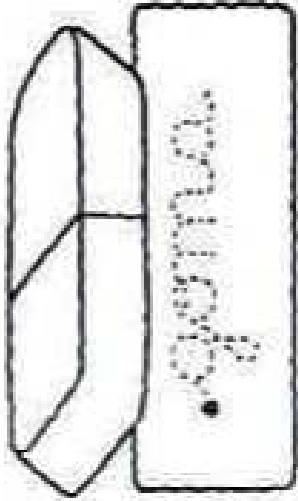
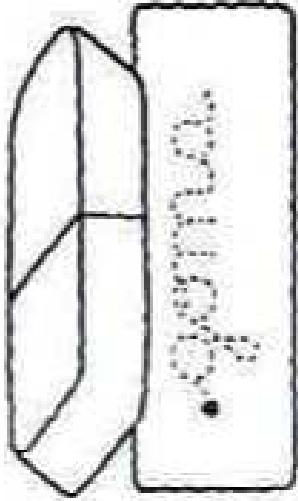
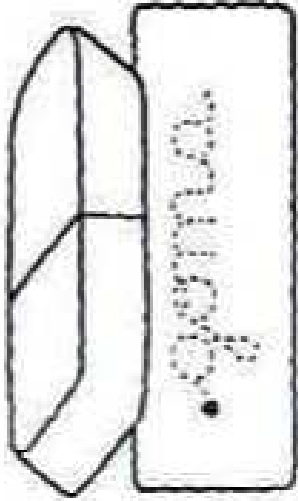
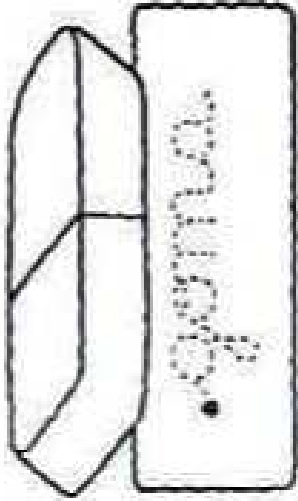
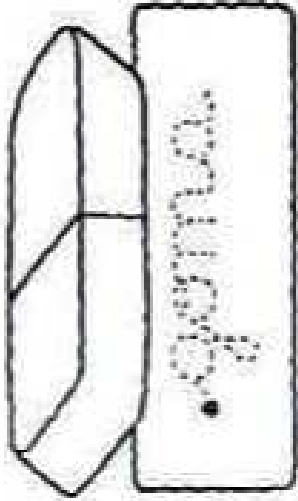
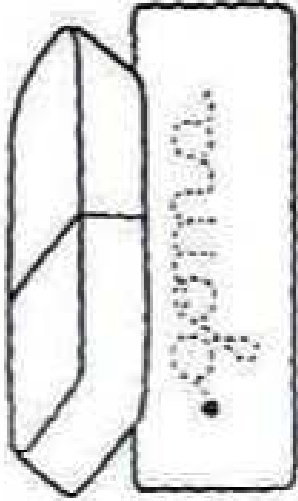
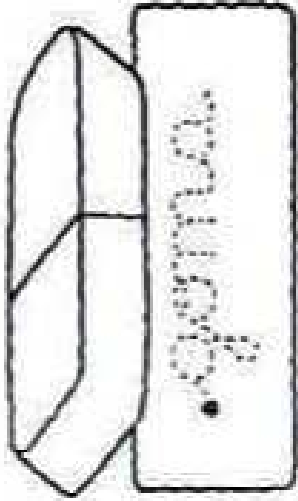
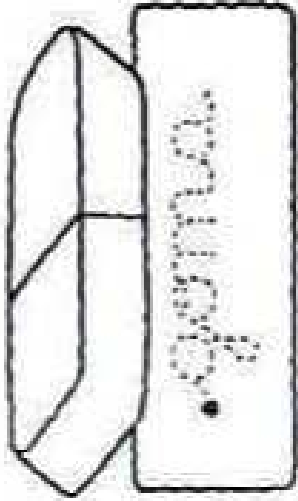
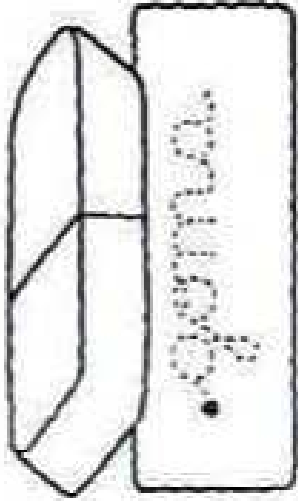
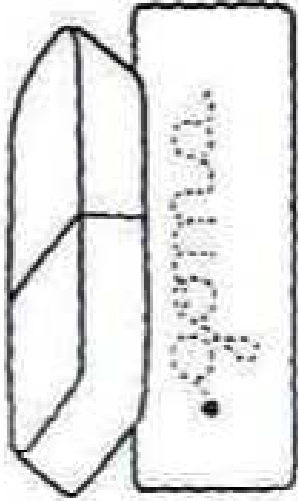
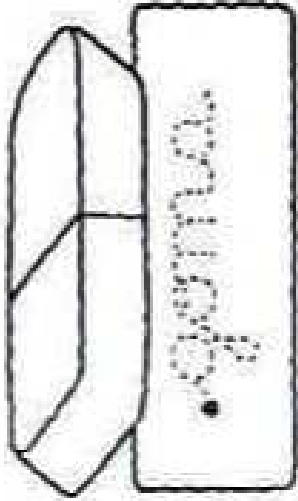
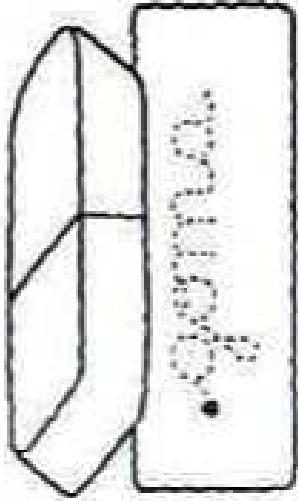
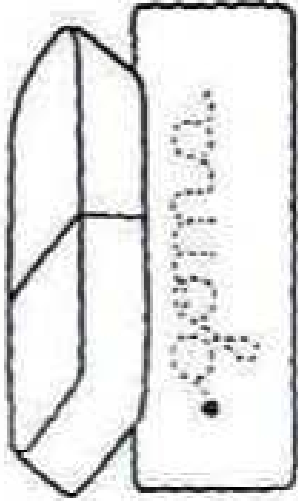
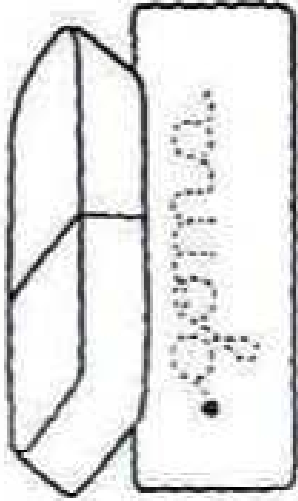
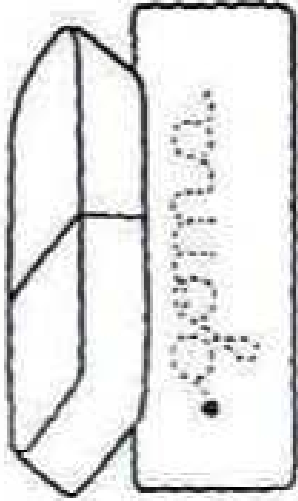
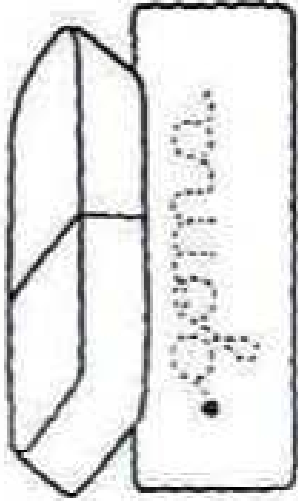
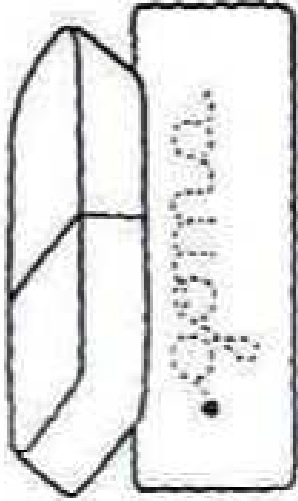
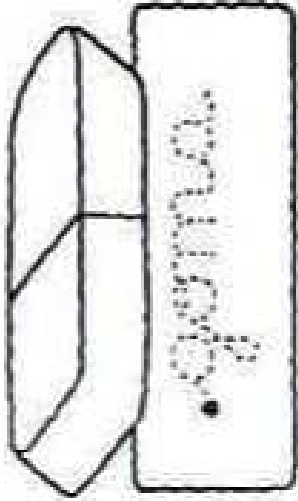
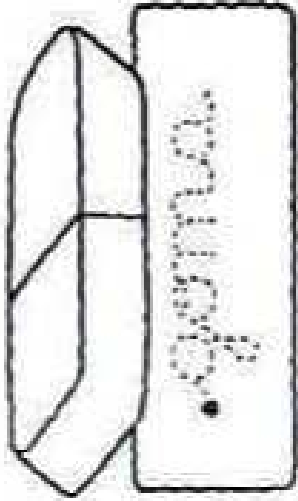
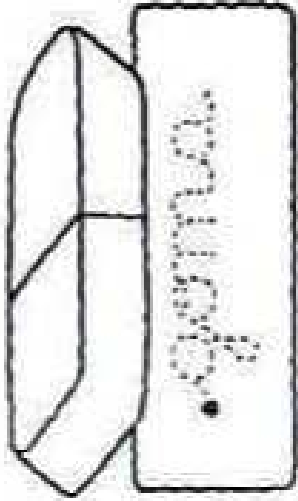
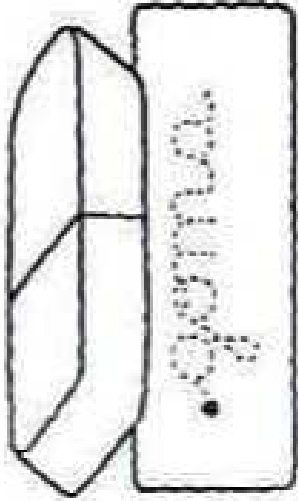
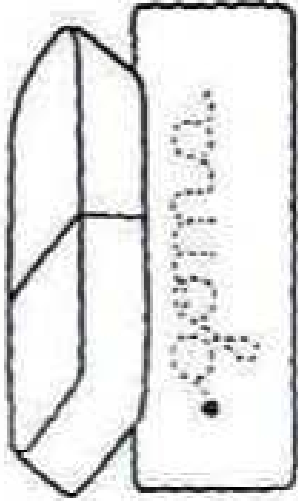
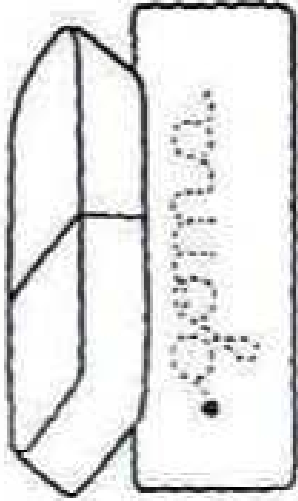
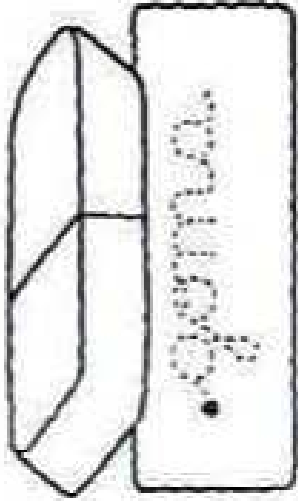
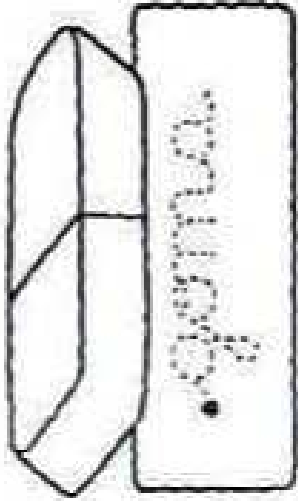
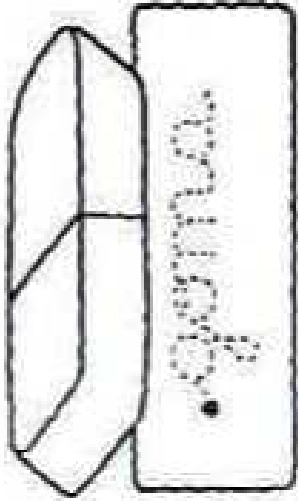
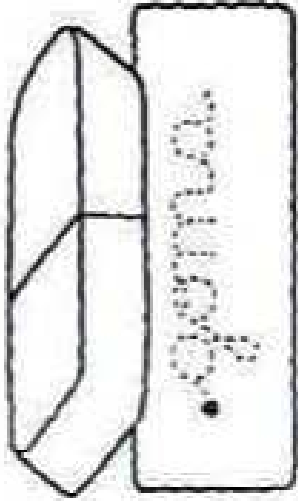
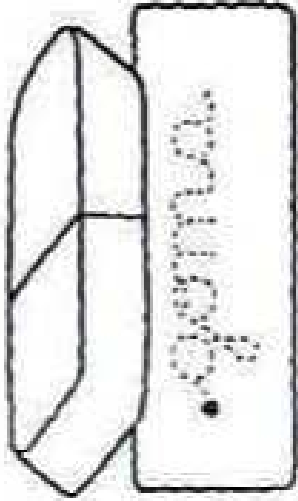
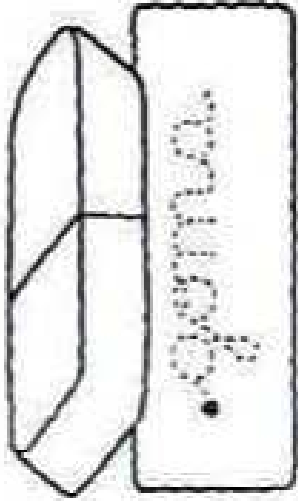
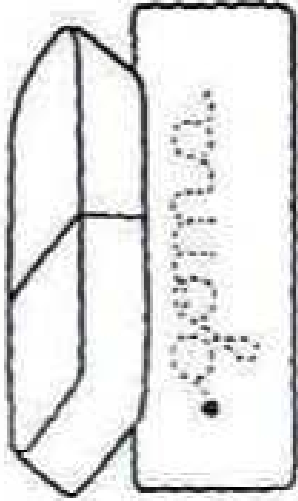
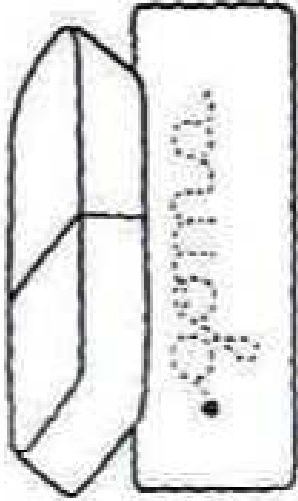
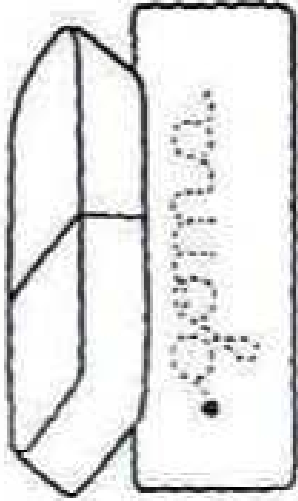
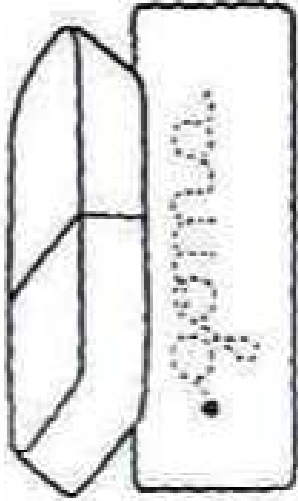
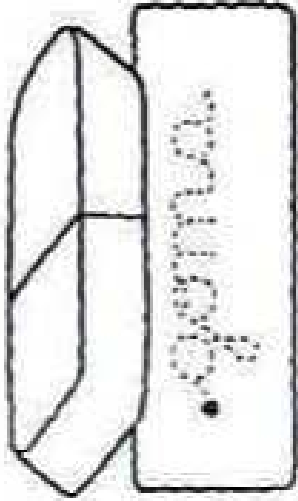
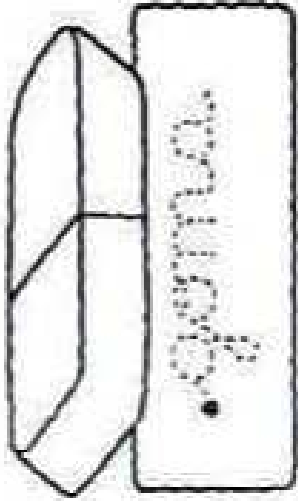
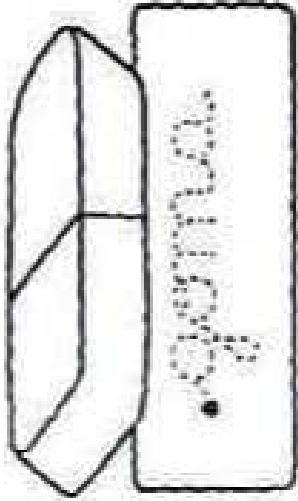
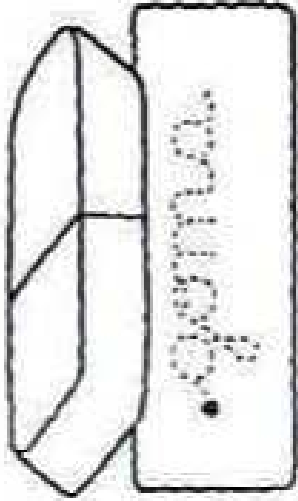
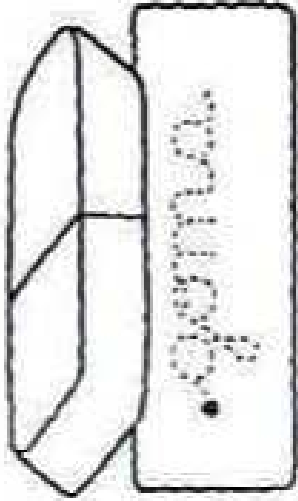
- RECORRE LAS LETRAS GRANDES CON TU DEDO ÍNDICE.
- DECÓRALAS COMO MÁS TE GUSTE.

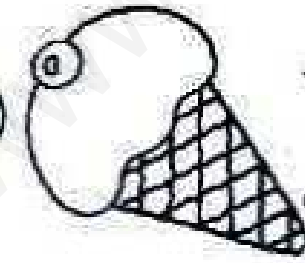
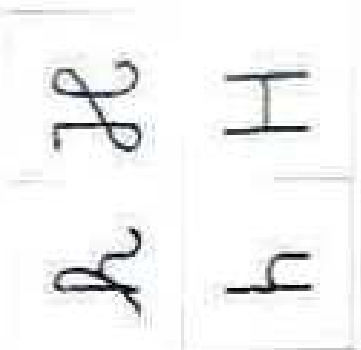
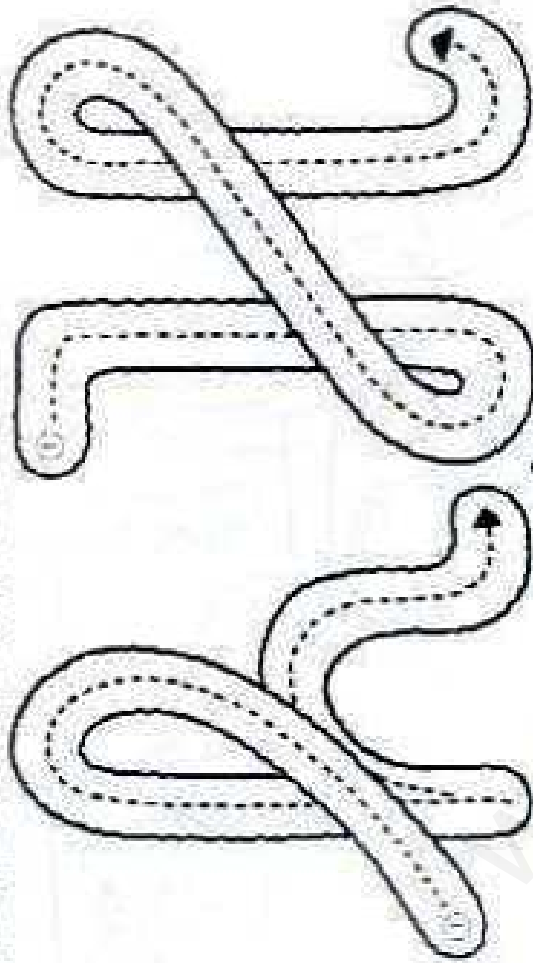

helado

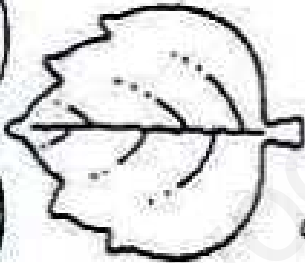

hoja

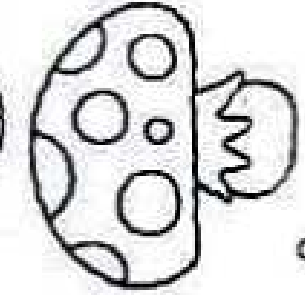

hongo

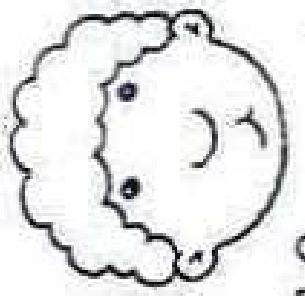

Horacio

- DELINEA Y COMPLETA CADA RENGLÓN.



h

ha

he

hi

ho

hu



- COLOREA LAS LETRAS EN LA DIRECCIÓN CORRECTA.
- UNE CADA OBJETO CON LA LETRA INICIAL CORRESPONDIENTE.

a b c d e f g h

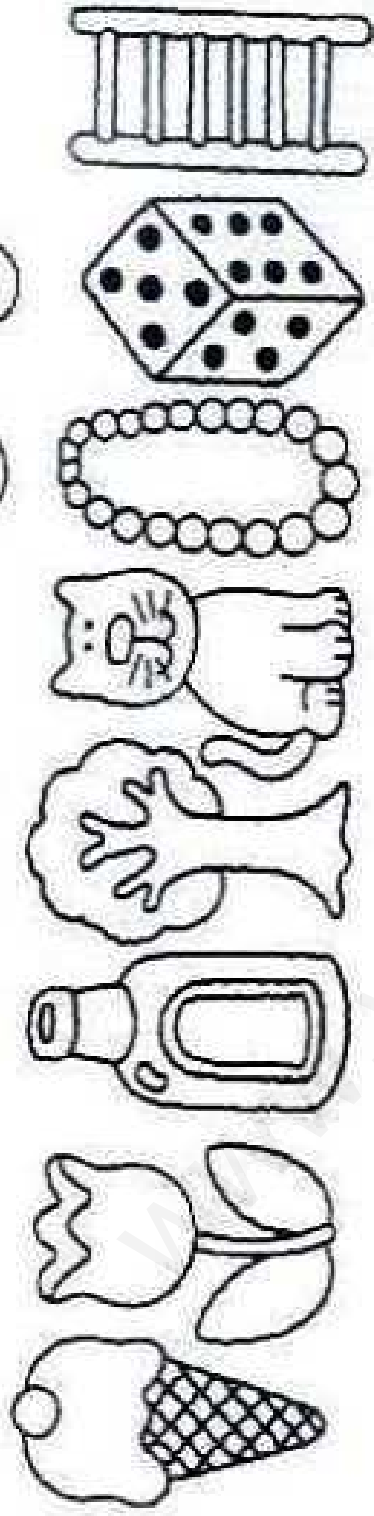

- DELINEA LAS PALABRAS Y CÓPIALAS DEBAJO.

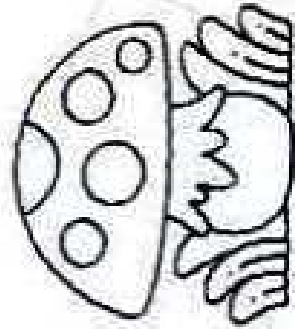

Mariposa

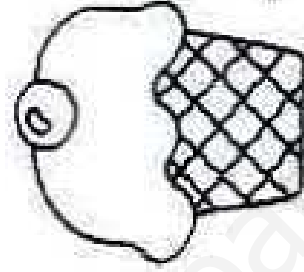

Balasto

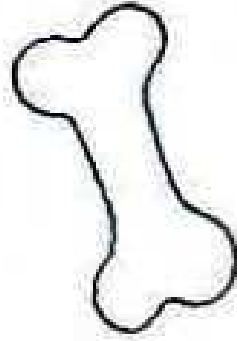

Hueso

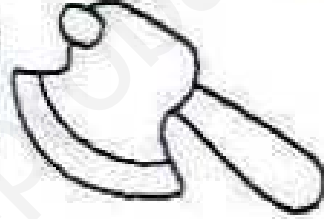

Martillo

- DELINEA LAS SÍLABAS Y CÓPIALAS DEBAJO.

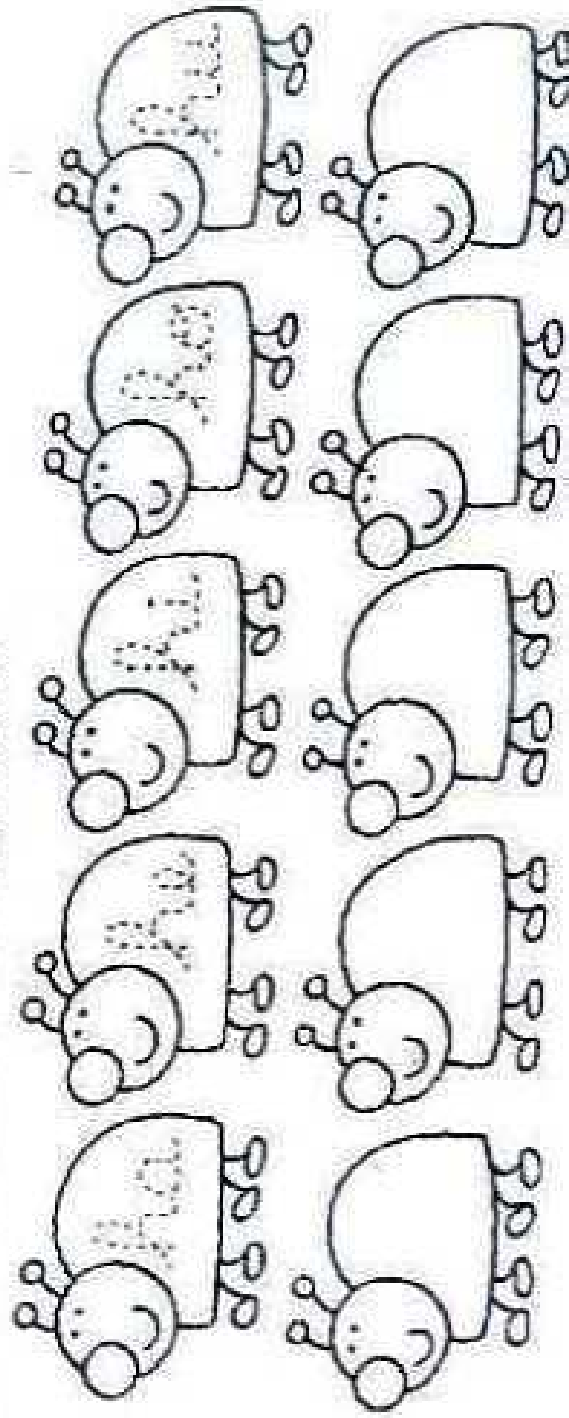

- RECORRE LAS LETRAS GRANDES CON TU DEDO ÍNDICE.
- DECÓRALAS CON PAPEL TROZADO CON TIJERA.

a b c d e f g h i j k l m n ñ o p q r s t u v w x y z

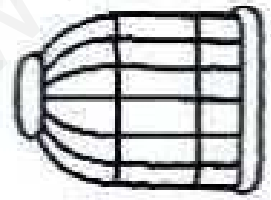
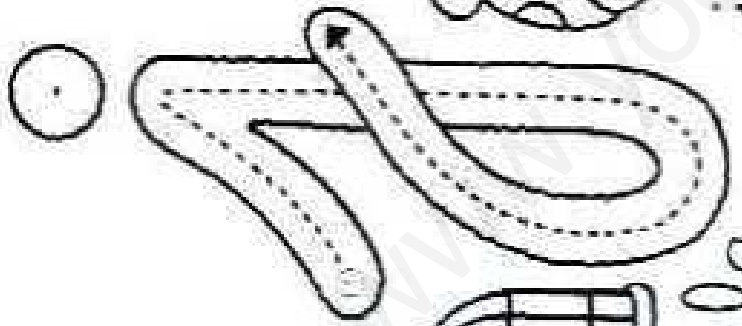
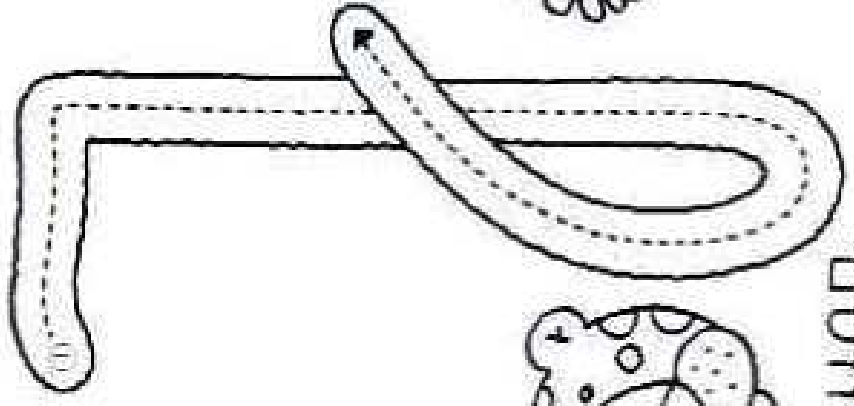

jaula

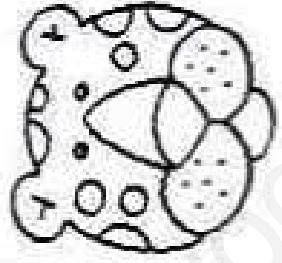

jaguar

j	J
i	I

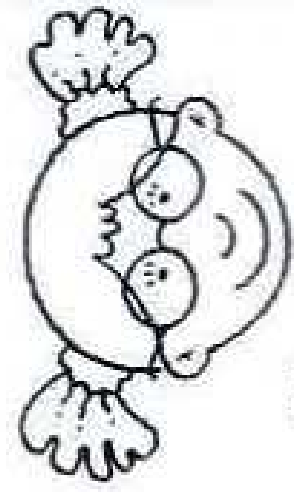

Juana









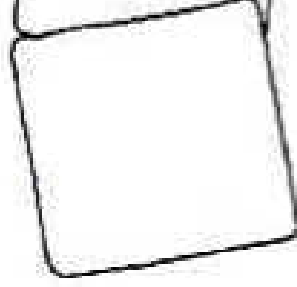

• DELINEA Y COMPLETA CADA RENGLÓN.

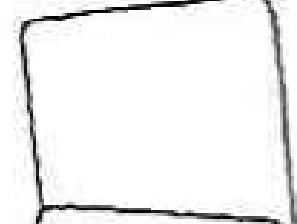
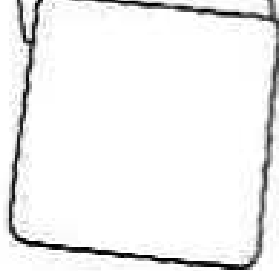
j i ja je ji jo ju

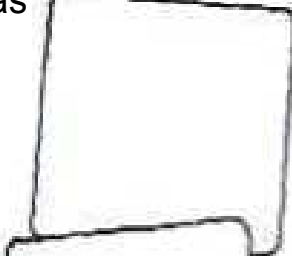
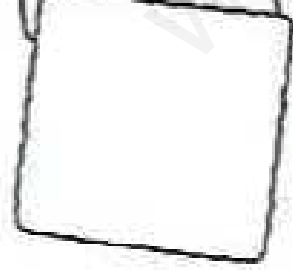

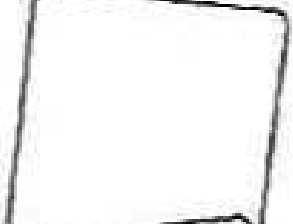
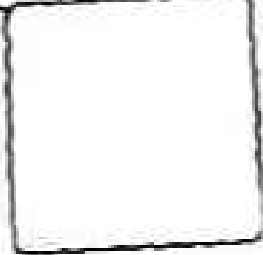
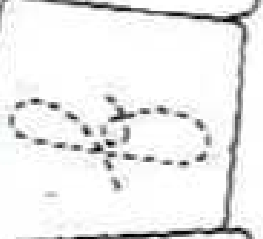
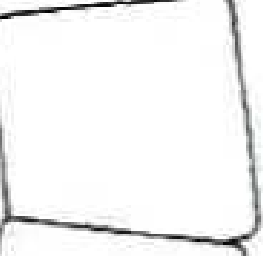
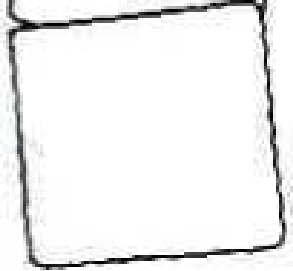
www.Odiprobar.es

- ESCRIBE LA LETRA ANTERIOR A LA IZQUIERDA Y LA POSTERIOR A LA DERECHA.
- DELINEA CON ROJO LA LETRA DEL MEDIO.

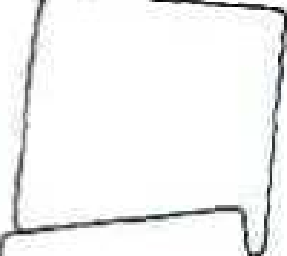
- DELINEA Y COPIA CADA PALABRA MIENTRAS LA LEES EN VOZ ALTA.
- COLOREA LOS OBJETOS.

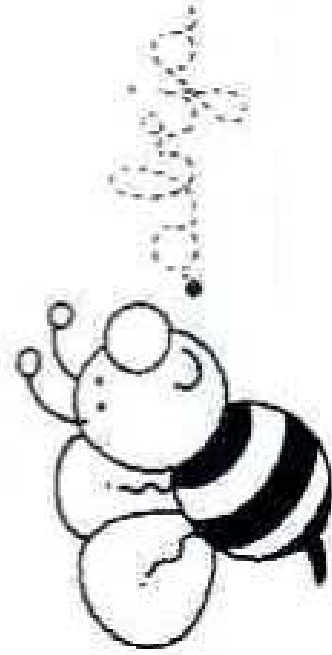
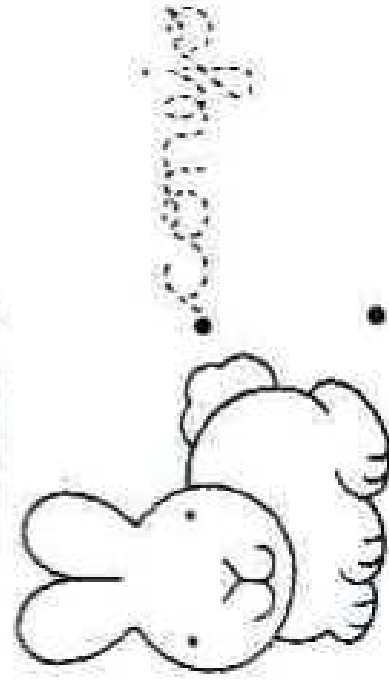
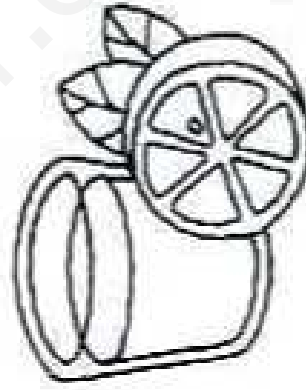
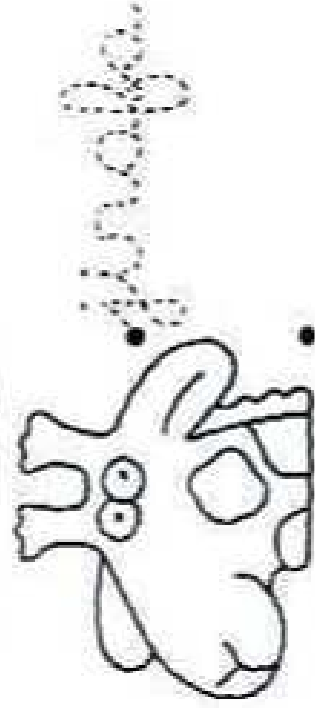

- UNE LAS LETRAS EN ORDEN ALFABÉTICO PARA FORMAR EL DIBUJO.
- COLOREA EL FONDO DEL MAR.

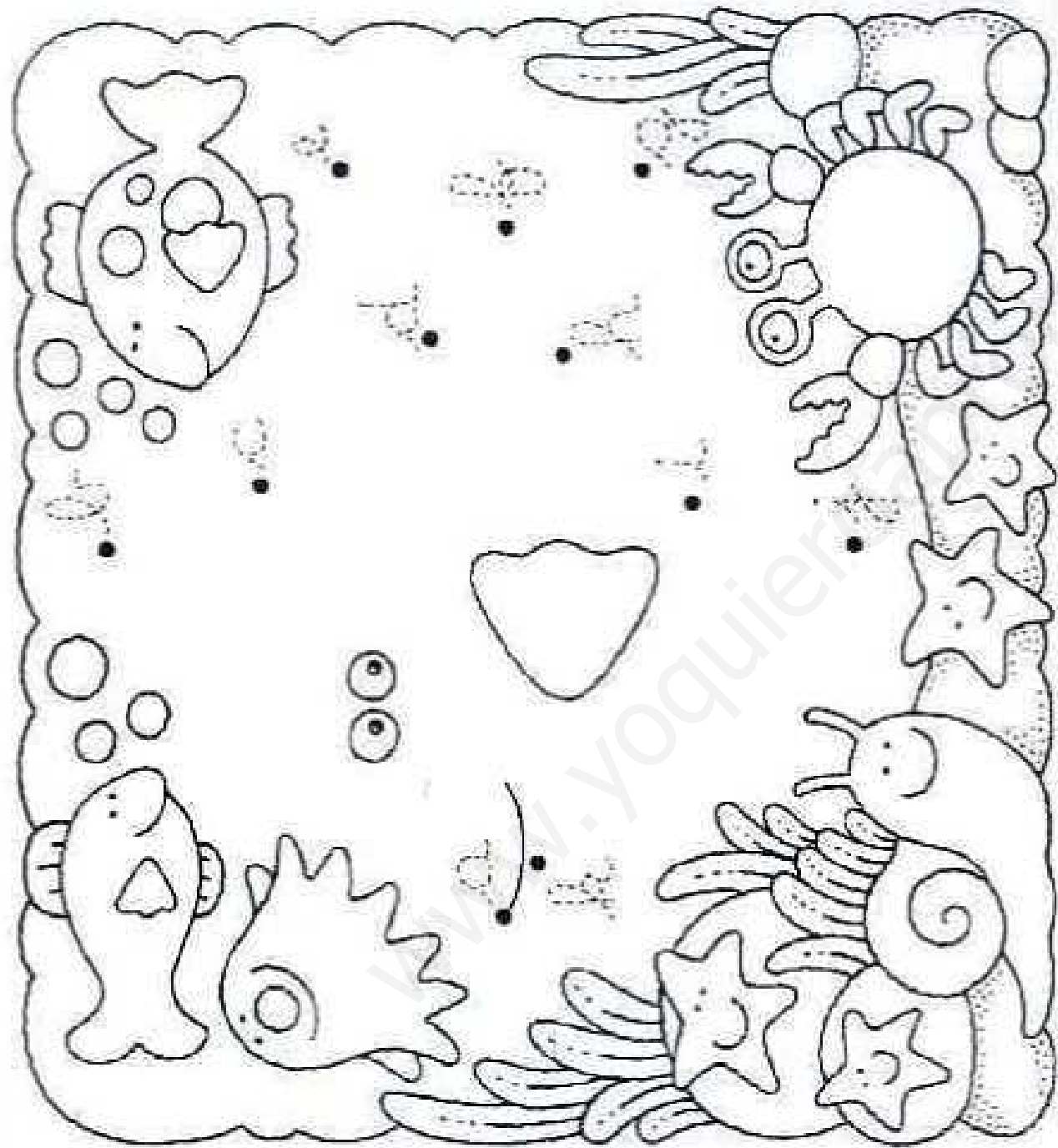

- DELINEA CADA PALABRA MIENTRAS LA LEES EN VOZ ALTA. LUEGO CÓPIALA.



Arriba

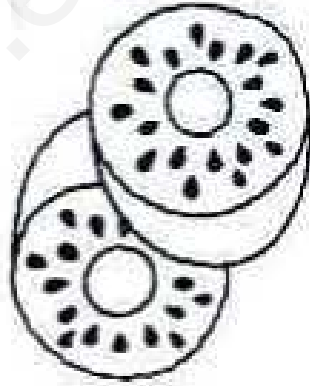

Arriba

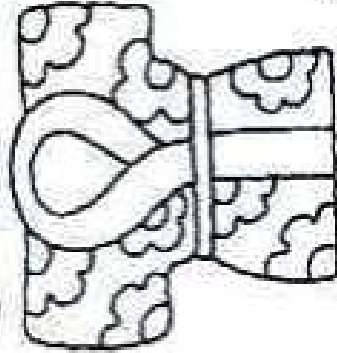

Arriba

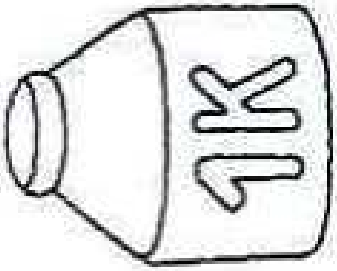

Arriba

- RECORRE LAS LETRAS GRANDES CON TU DEDO ÍNDICE.
- DECÓRALAS COMO MÁS TE GUSTE.

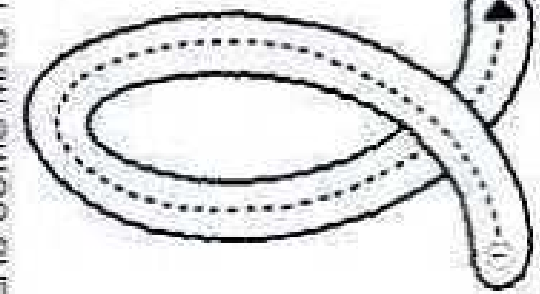

lápiz

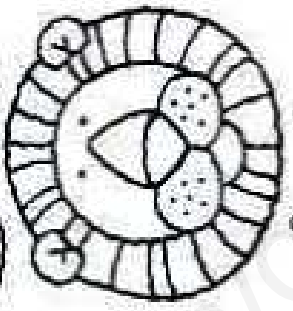
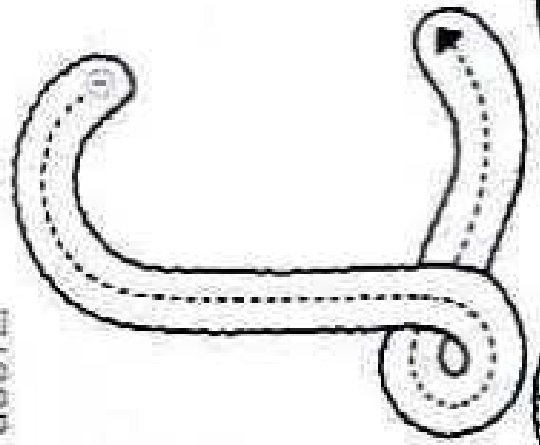

león

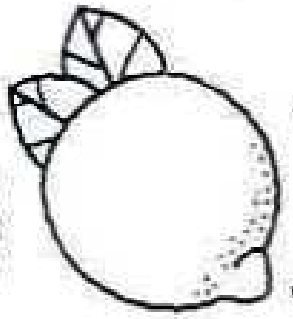

limón



lola

l	l
	L

- DELINEA Y COMPLETA CADA RENGLÓN.

l la le li lo lu



- COLOREA LOS DIBUJOS QUE COMIENZAN CON "L".
- ESCRIBE LA LETRA A LA IZQUIERDA DE CADA UNO DE ELLOS.

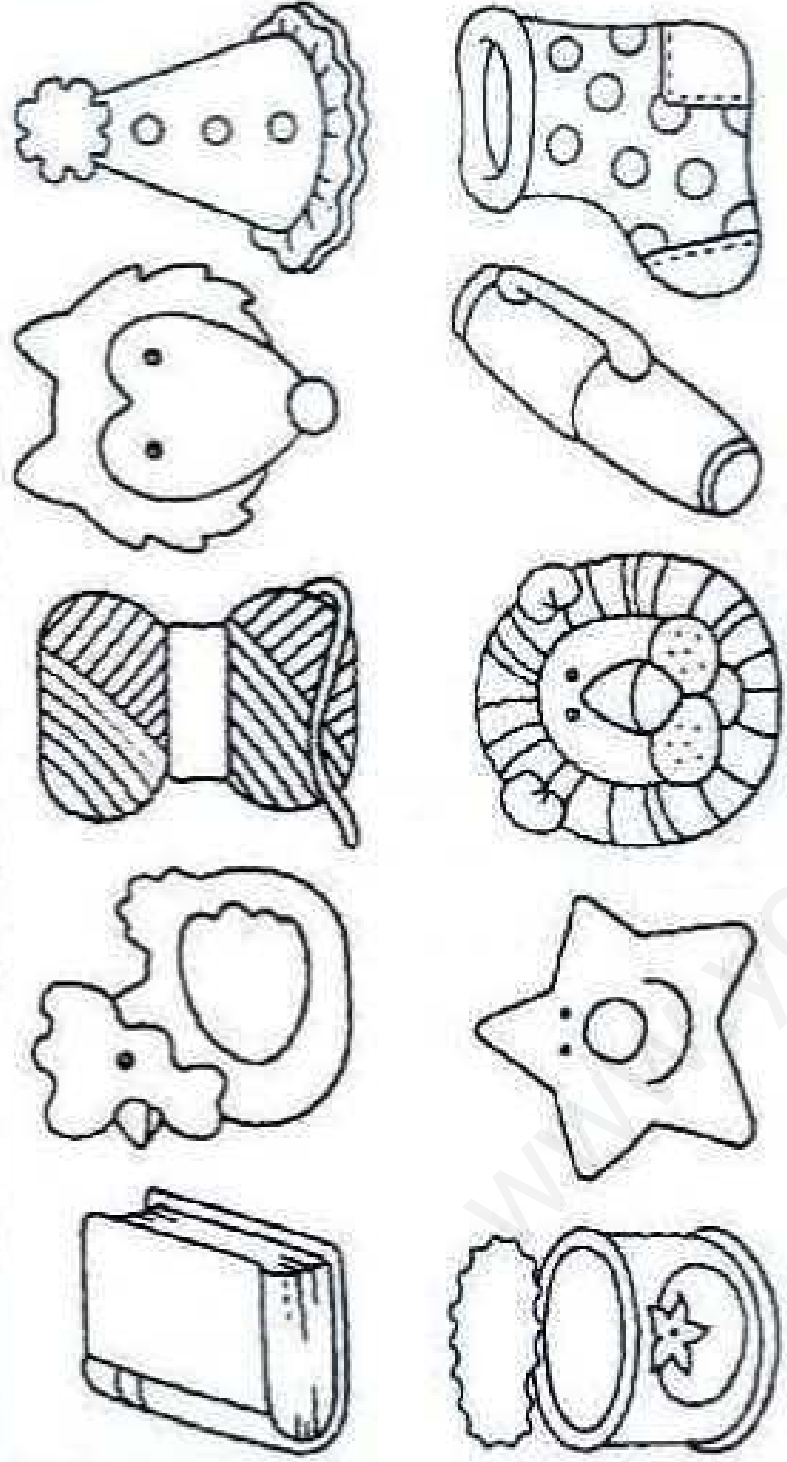

- DELINEA EL RECORRIDO DE LOLA, LA MARIQUITA.

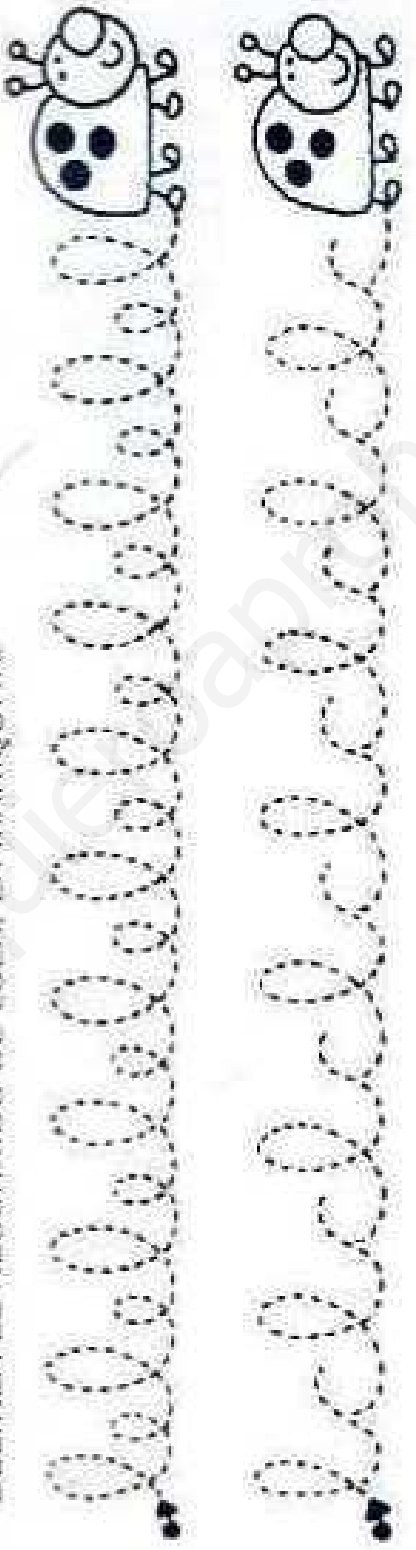

- DELINEA Y COPIA LAS PALABRAS MIENTRAS LAS DELETREAS EN VOZ ALTA.

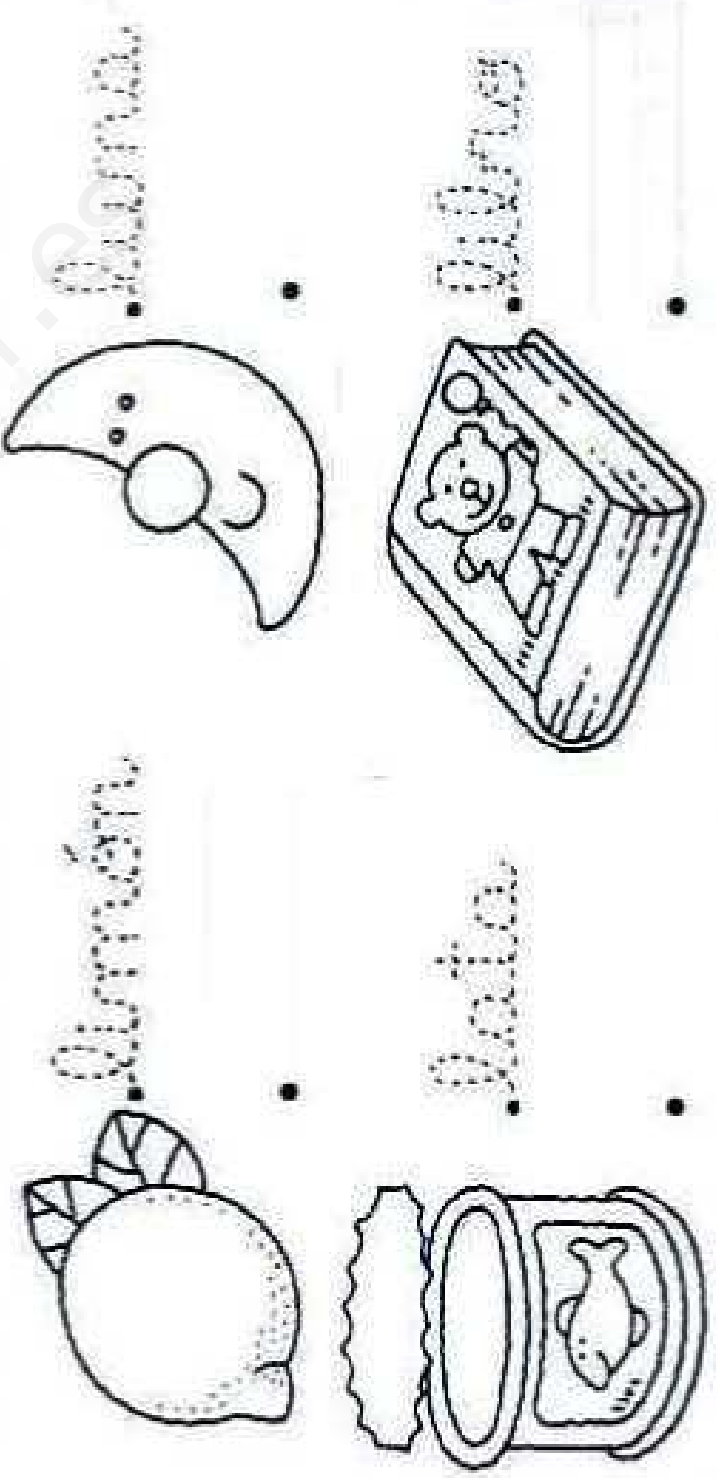

- RECORRE LAS LETRAS GRANDES CON TU DEDO INDICE.
- DECÓRALAS COMO MÁS TE GUSTE.

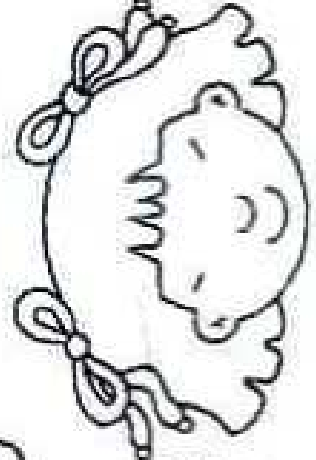
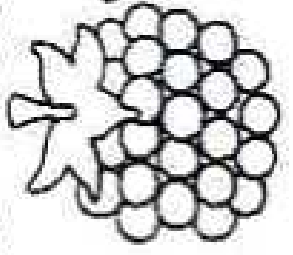
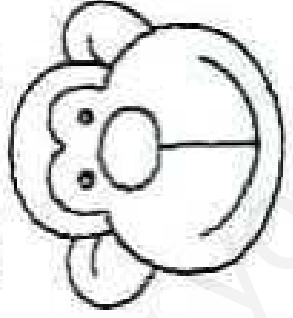
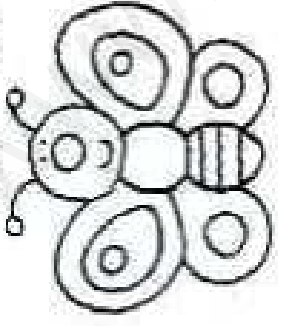
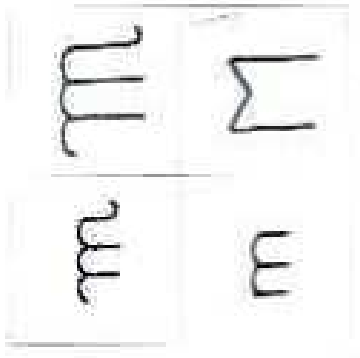
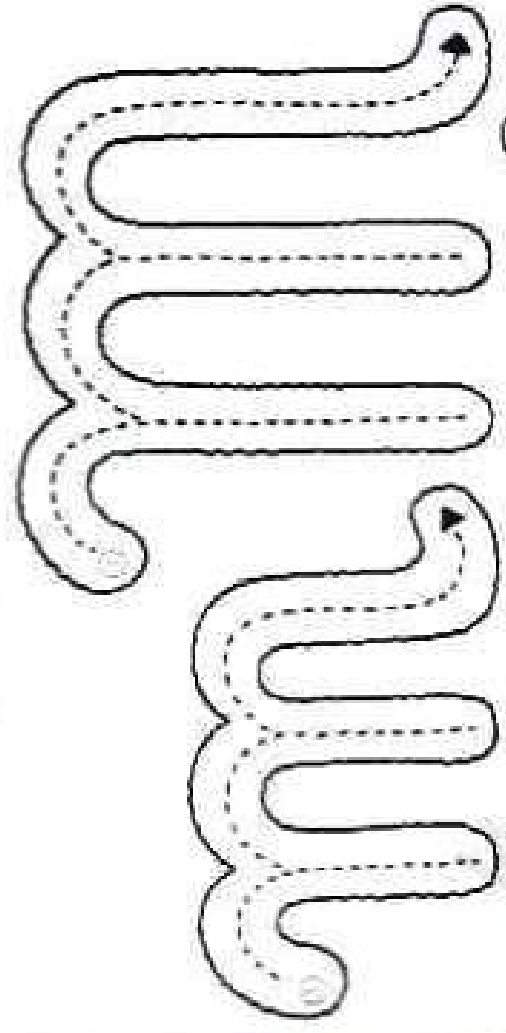

mariposa

mono

uvas

Maria

- DELINEA Y COMPLETA CADA RENGLÓN.

m

m

ma

me

mi

mo

mu

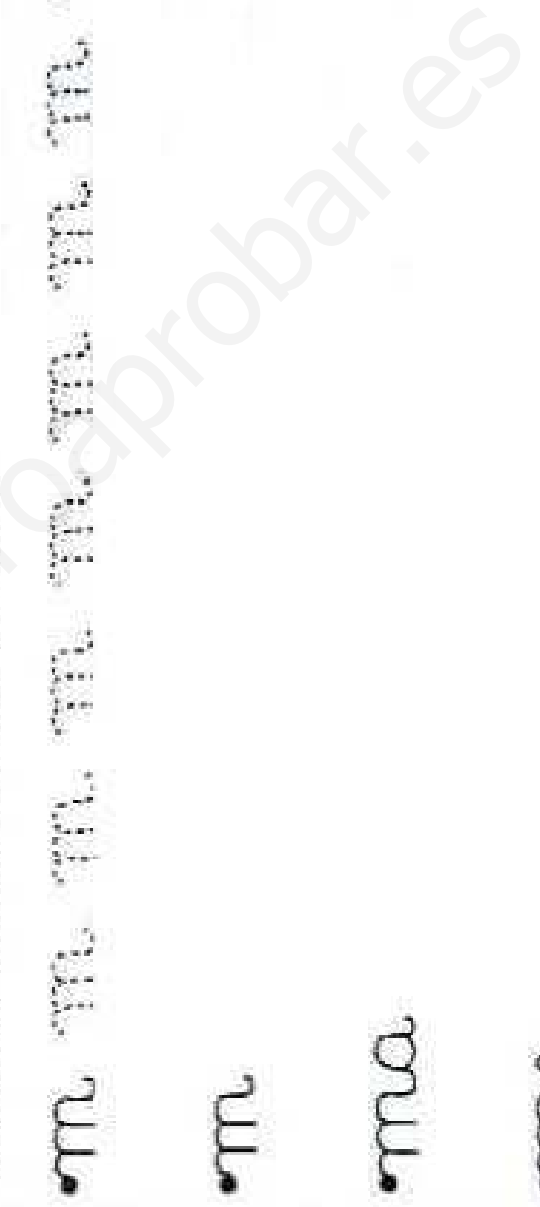

- DELINEA LAS SILABAS CON DISTINTOS COLORES Y REPITELAS EN VOZ ALTA.
- UNIENDO DOS O MÁS SILABAS PUEDES FORMAR PALABRAS. ESCRIBELAS DEBAJO.

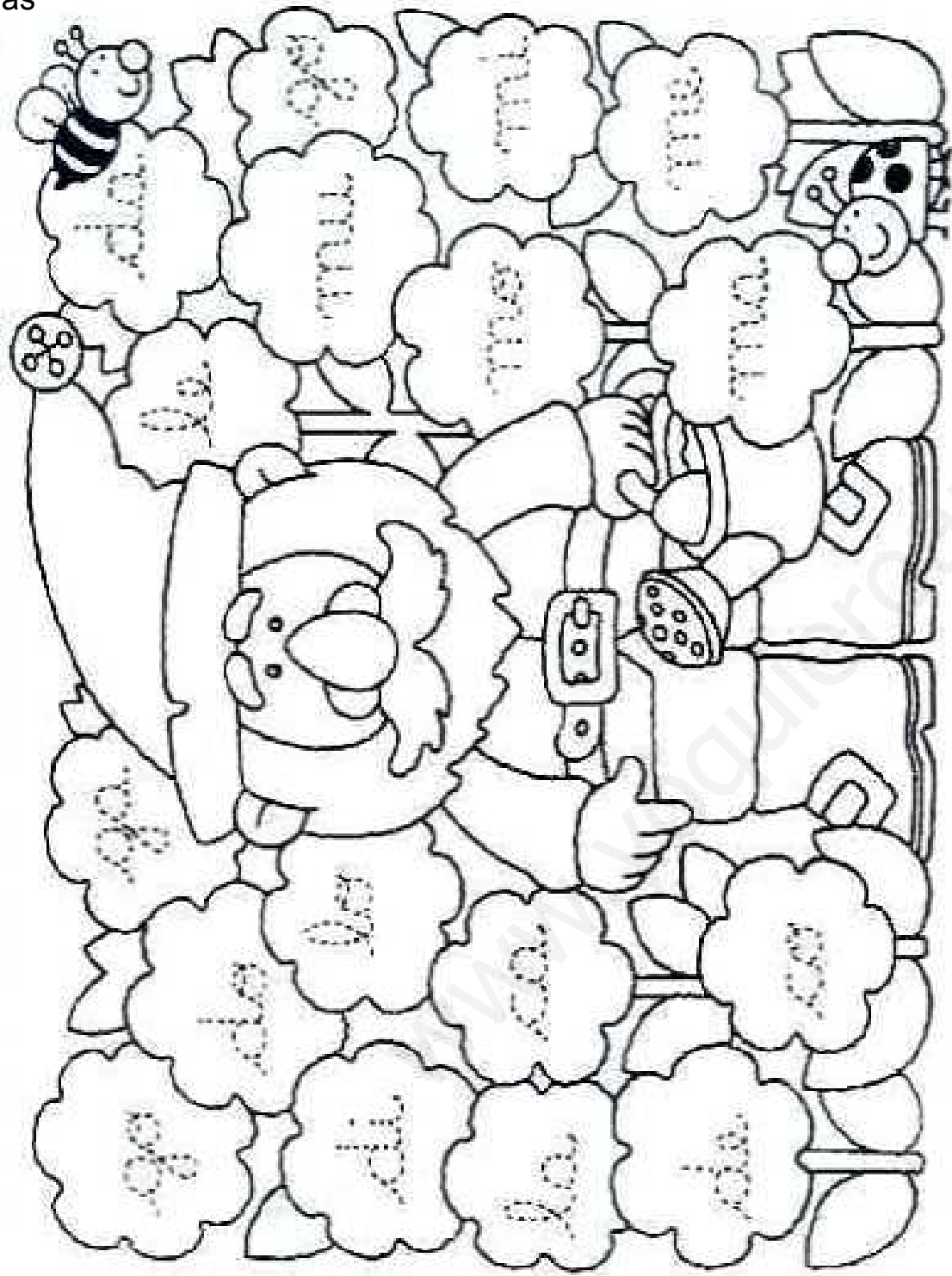

- DELINEA Y COPIA CON LAPIZ ESTAS PALABRAS.

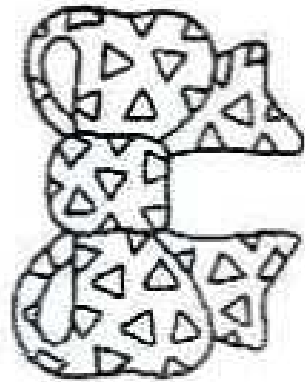

tigre

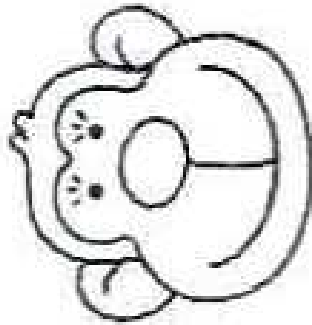

mono

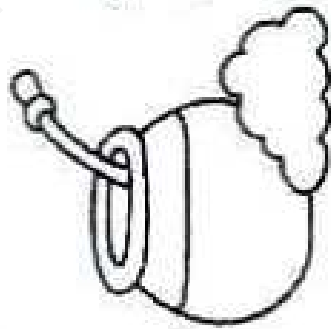

globo

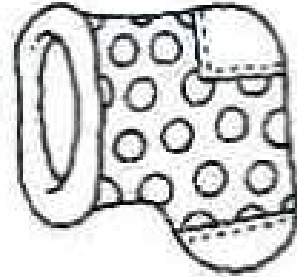

zapatos

- RECORRE LAS LETRAS GRANDES CON TU DEDO ÍNDICE.
- DECORALAS CON CRUCECITAS DE COLORES.

a b c d e f g h i j k l m n ñ o p q r s t u v w x y z

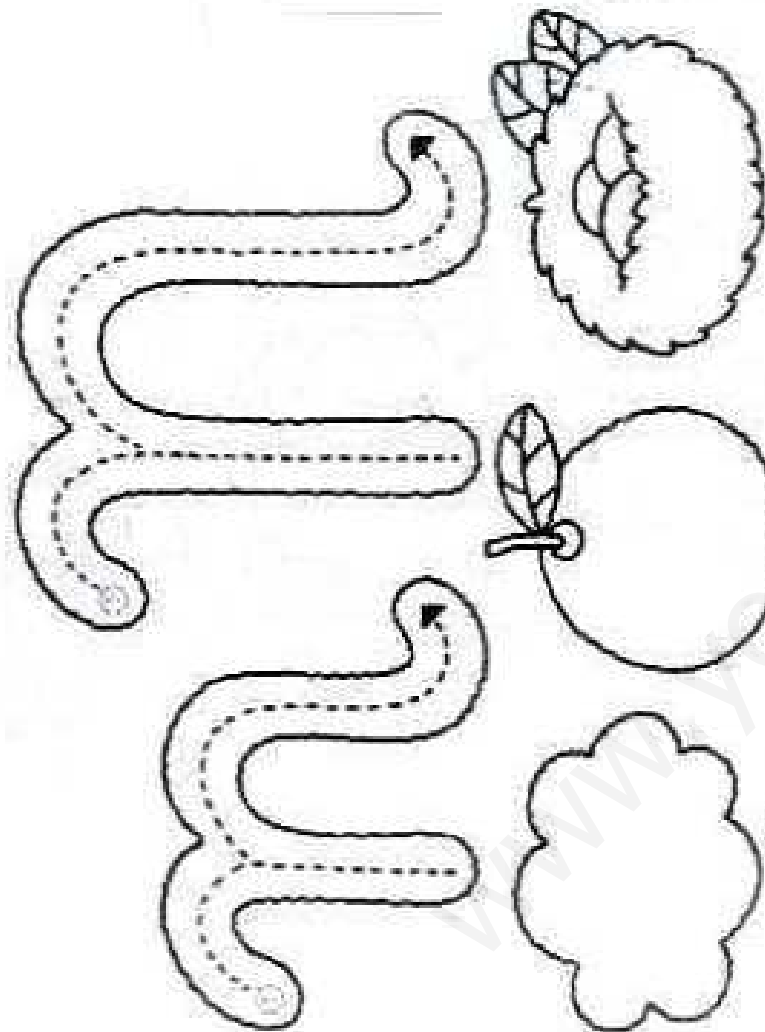

n N



Nahuel

nube naranaja nido

- DELINEA Y COMPLETA CADA RENGLÓN.

n N n N n N n N n N n

n

na

ne

ni

no

nu

WUOLAPROBAR.ES

• COMPLETA LOS ESPACIOS CON LA LETRA INICIAL DE CADA OBJETO. USA ESAS LETRAS PARA FORMAR LA ÚLTIMA PALABRA.

Letras
42

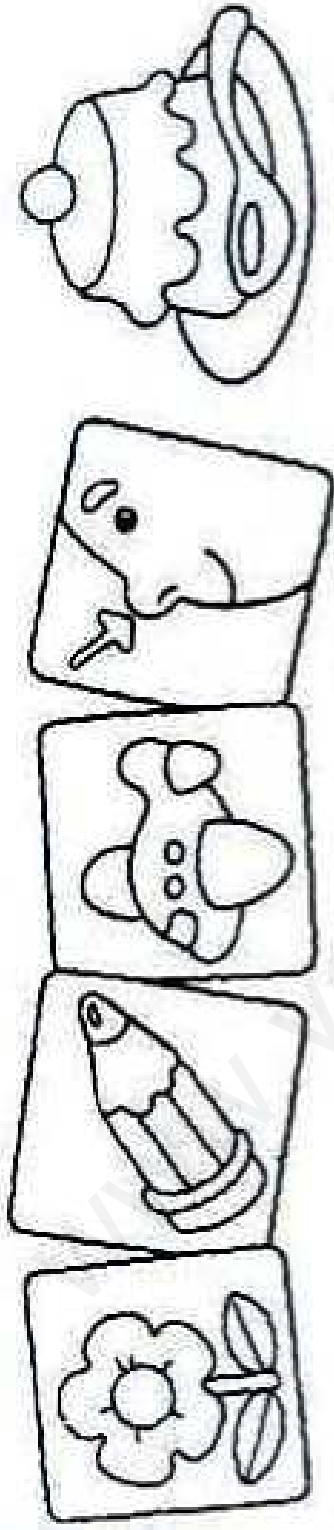
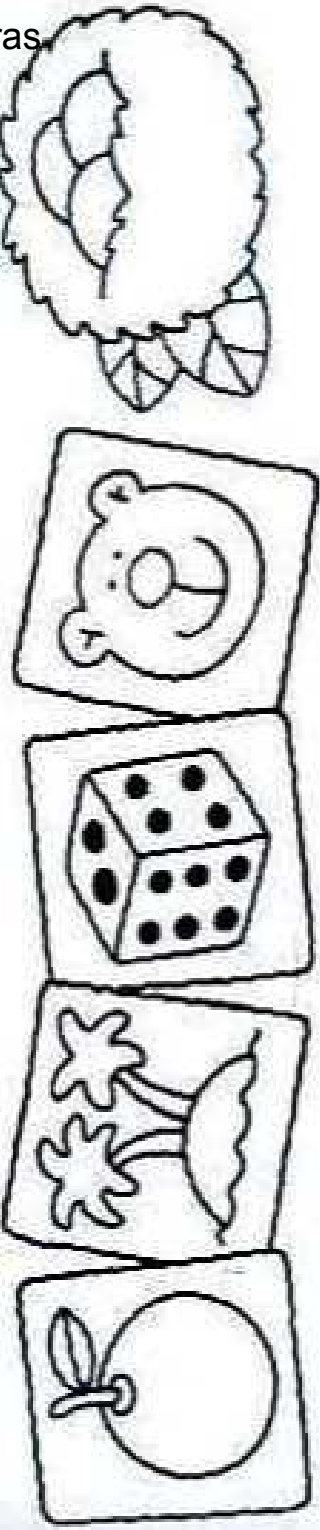

• DELINEA EL RECORRIDO DE LAS ABEJAS.

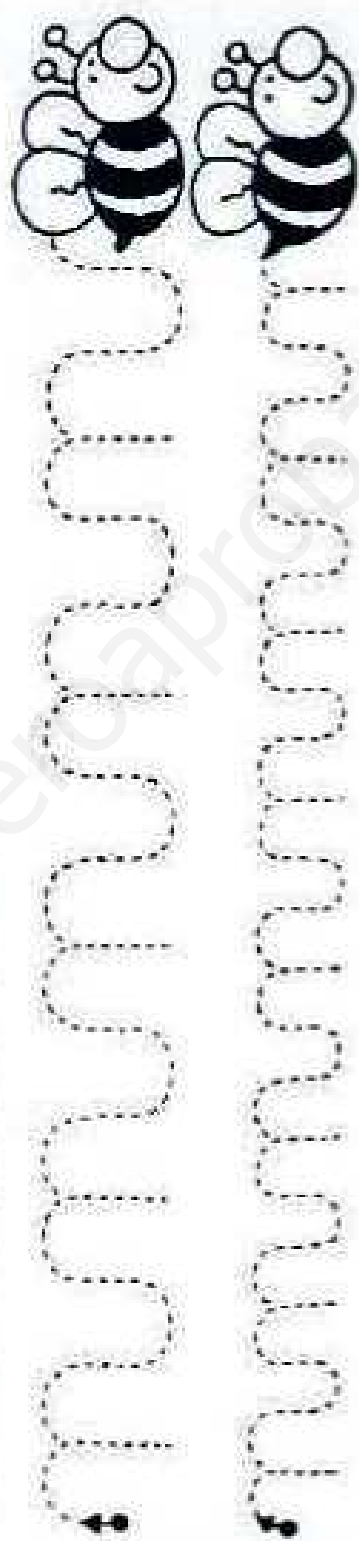

• DELINEA ESTAS PALABRAS Y UNELAS CON LAS FRUTAS CORRESPONDIENTES.
• SUBRAYA LAS PALABRAS QUE CONTENGAN LA "N".

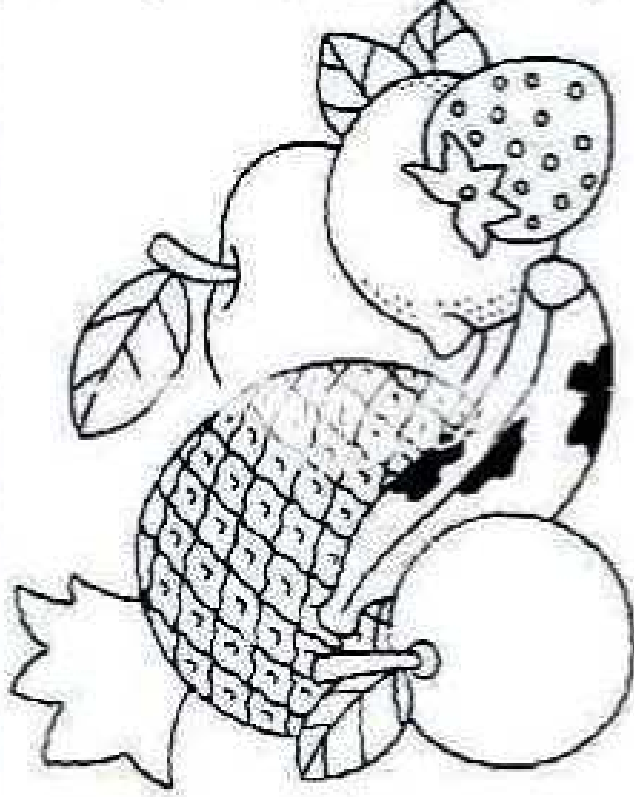

manzana
naranja
mandarina
naranja
naranja

- DELINEA Y COMPLETA CADA PALABRA CON LA LETRA QUE FALTA.
- COLOREA LOS DIBUJOS.

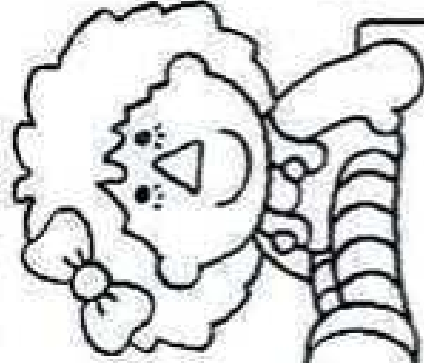

mulera

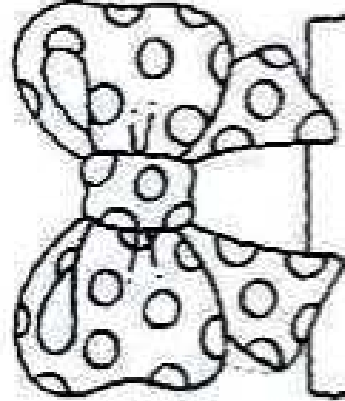

mulo

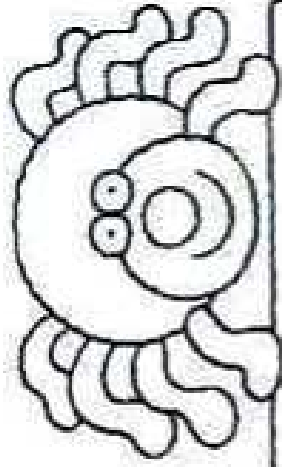

mulo

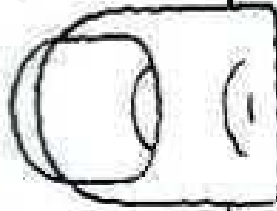

mul

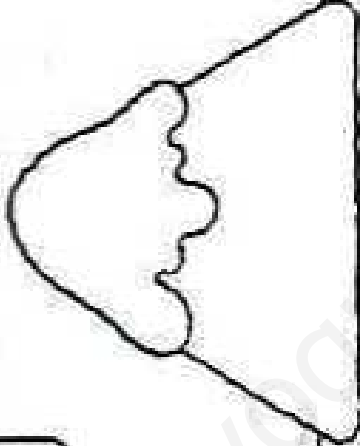

mulo

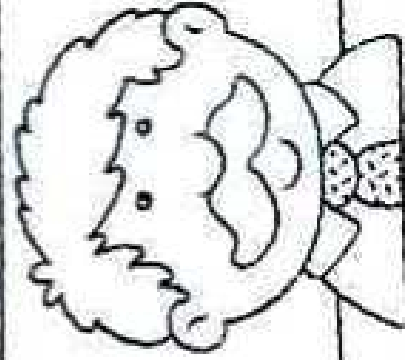

mulo

- DELINEA EL RECORRIDO DE CADA LOMBRIZI

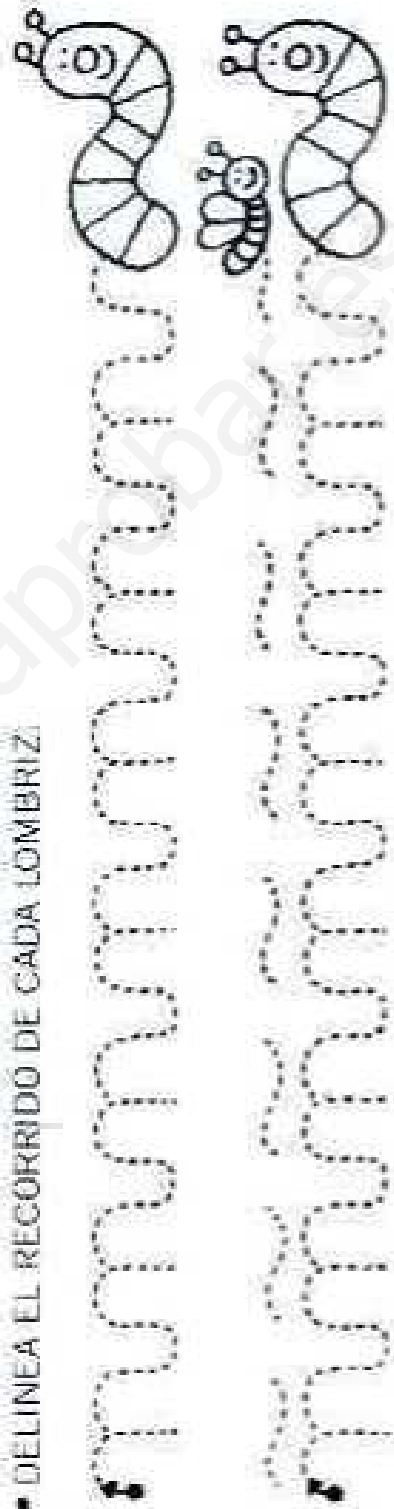

- RODEA CON COLOR LAS LETRAS IGUALES AL MODELO.

m m w n m n m n

n m n ñ u n w ñ n

ñ ñ n ñ m w u ñ n

- RECORRE LAS LETRAS GRANDES CON TU DEDO INDICE.
- DECÓRALAS CON LUNARES DE COLORES.

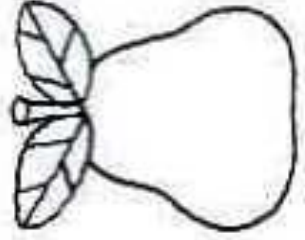
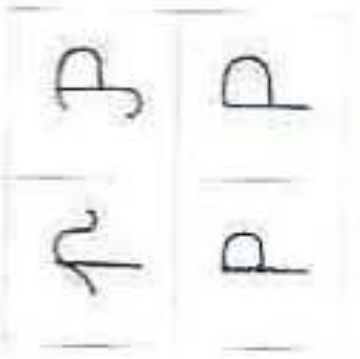
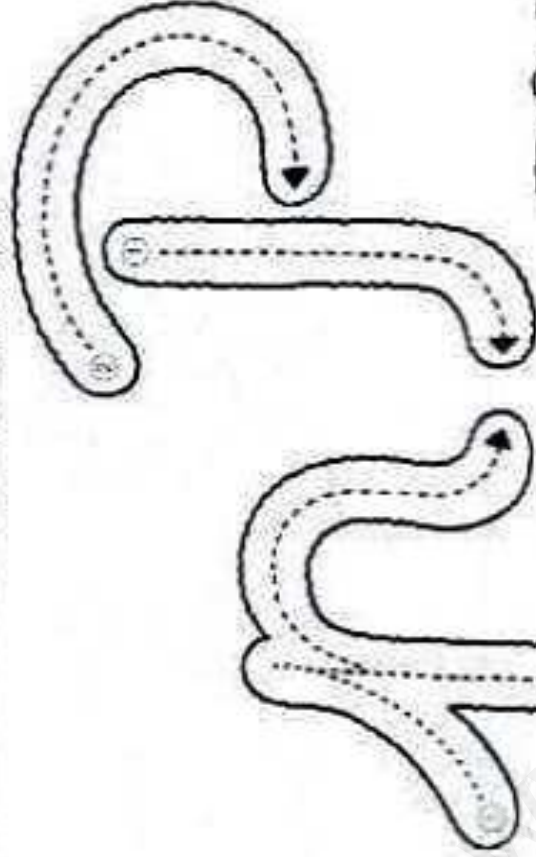

pera

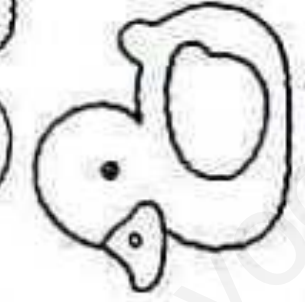

pato



pluma



Pedro

• DELINEA Y COMPLETA CADA RENGLÓN.



P p pa pe pi po pu



• DELINEA LAS LETRAS.
• ESCRIBE DEBAJO LA PALABRA QUE PUEDES FORMAR CON ESAS LETRAS.

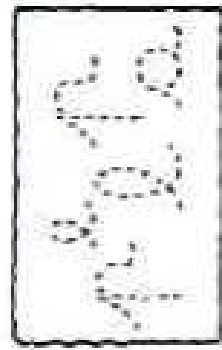
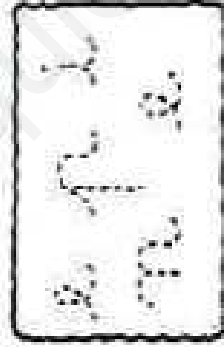
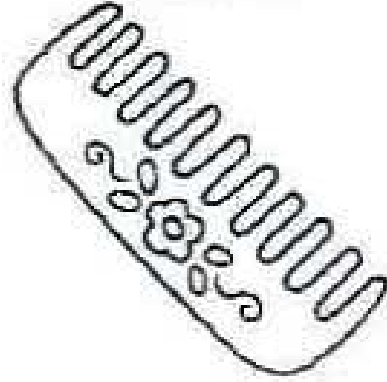
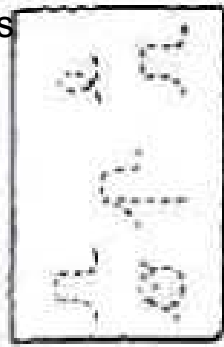
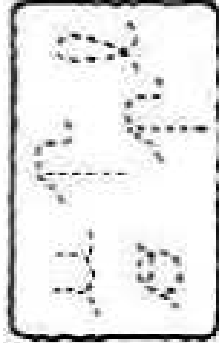
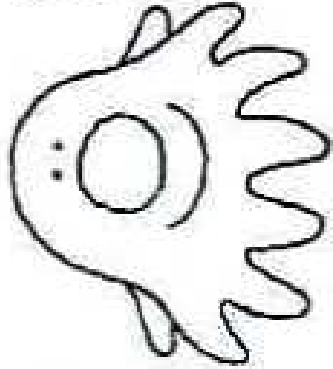

• COLOREA, DELINEA Y UNE LOS OBJETOS CON LA SILABA INICIAL CORRESPONDIENTE.

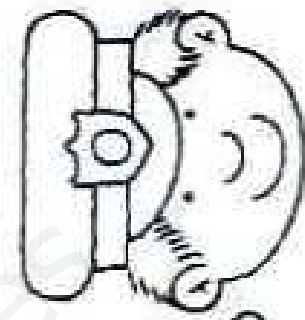
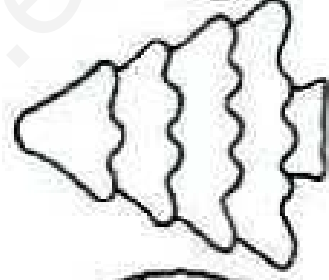
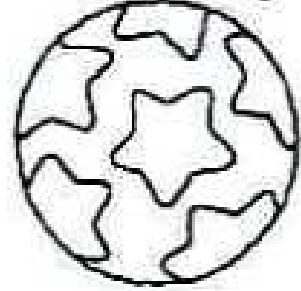
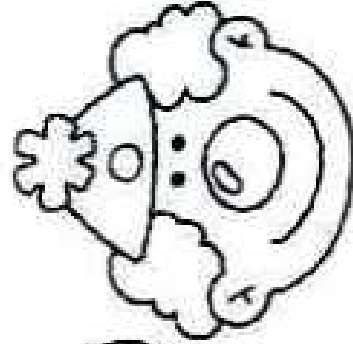
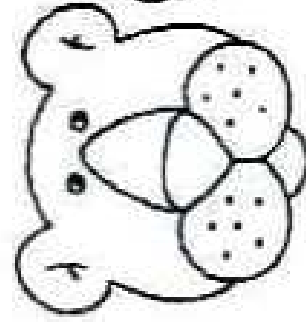

na ne ni no nu
pa pe pi po pu

- RECORRE LAS LETRAS GRANDES CON TU DEDO INDICE.
- DECÓRALAS COMO MÁS TE GUSTE.

a b c d e f g h i j k l m n ñ o p q r s t u v w x y z

q Q

q Q



Quique

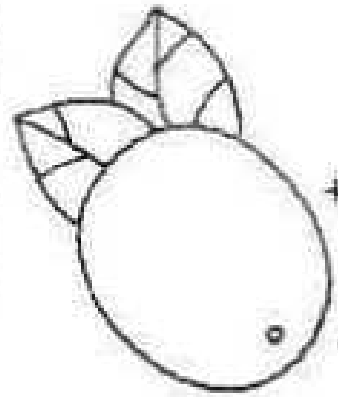
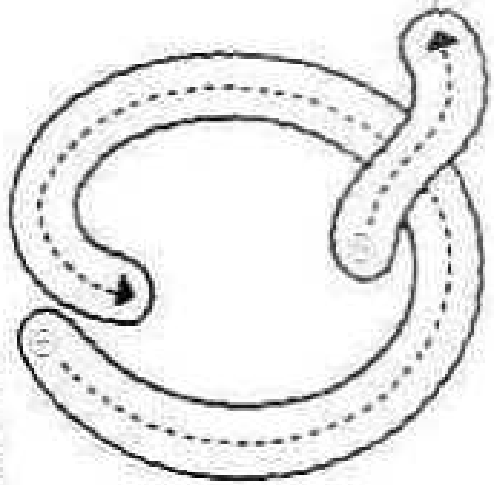

quimote

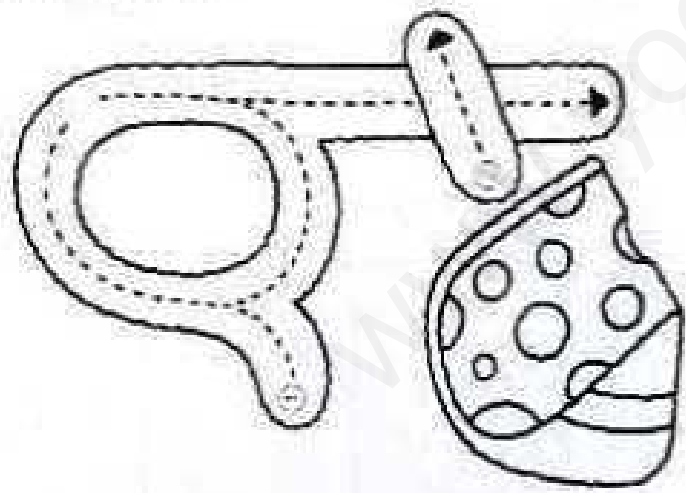

queso

- DELINEA Y COMPLETA CADA RENGLÓN.

q q q q q q q q q q

que - que

que - que

qui - qui

qui - qui

WATERPROOF PAPERBAR.ES

- RECORRE LAS LETRAS GRANDES CON TU DEDO INDICE.
- DECÓRALAS COMO MÁS TE GUSTE.

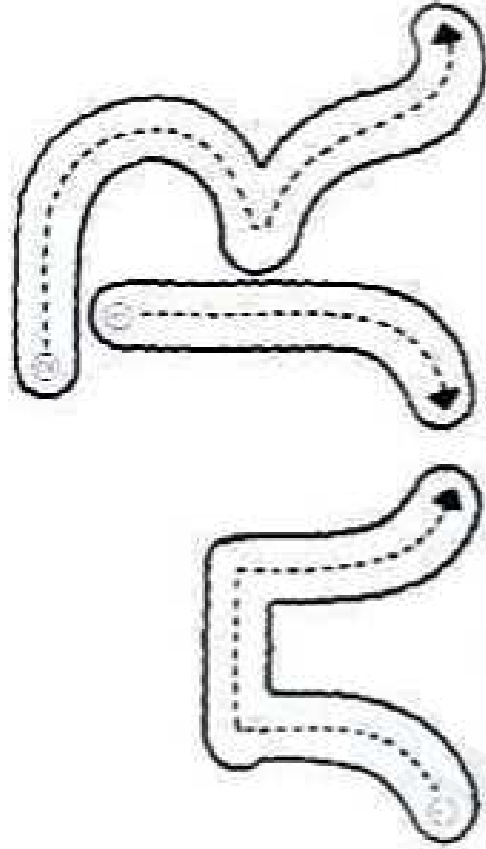

r	R
r	R

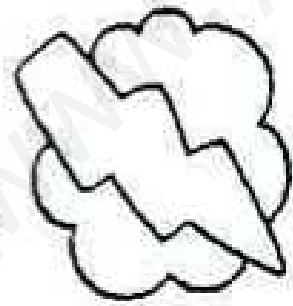

pintor pintor

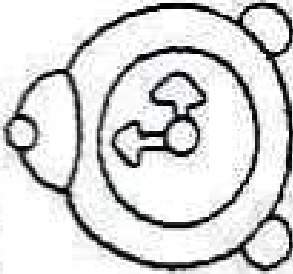

reloj reloj

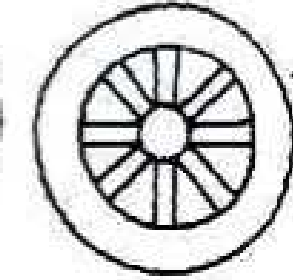

rueda rueda



Rita Rita

- DELINEA Y COMPLETA CADA RENGLÓN.

r r r r r r r r r r r r r r r r

r

ra

re

ri

ro

ru



- ESCRIBE CON ROJO LA LETRA INICIAL EN EL ESPACIO CORRESPONDIENTE.
- DELINEA CADA PALABRA.

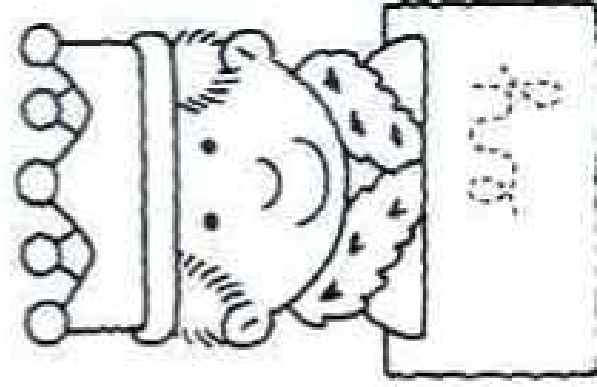
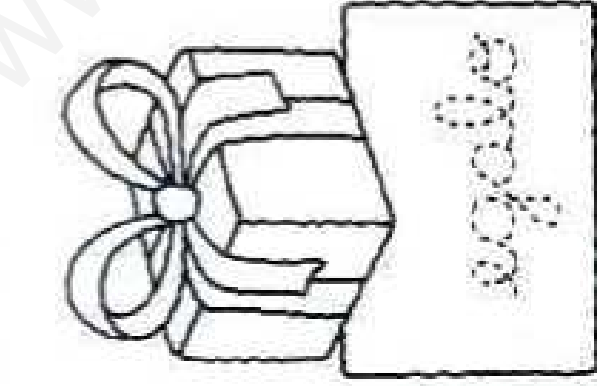
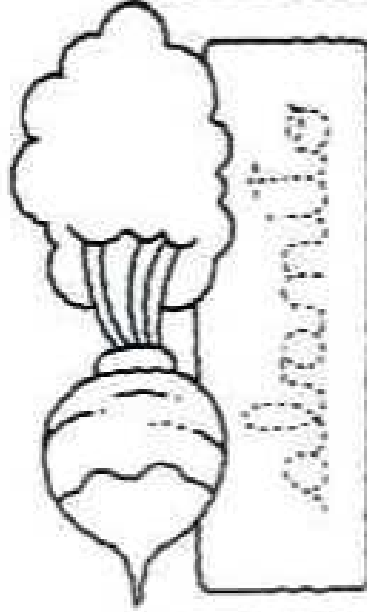
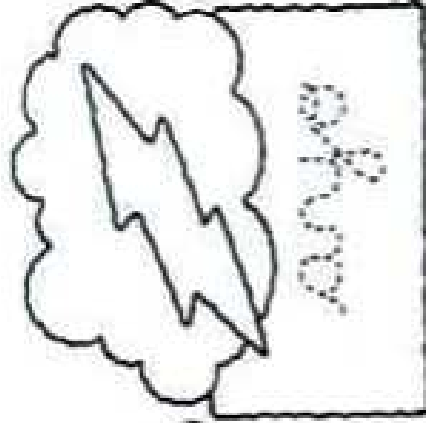
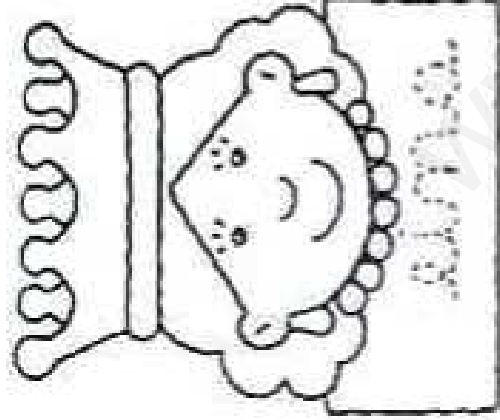

- TRANSCRIBE CADA PALABRA A LETRA CURSIVA.

REINO

RAZÓN

RUEDA

- RECORRE LAS LETRAS GRANDES CON TU DEDO ÍNDICE.
- DECÓRALAS COMO MÁS TE GUSTE.

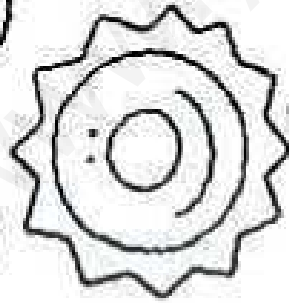
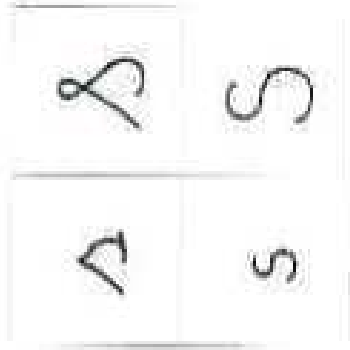
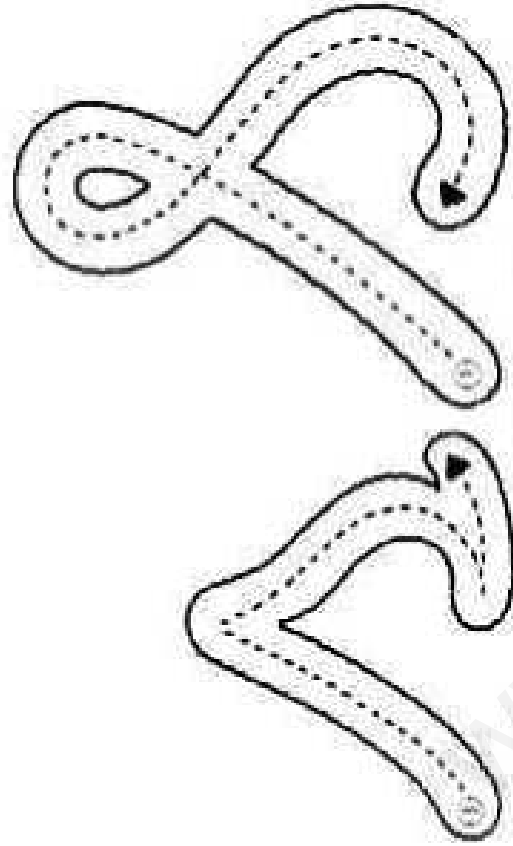

sol

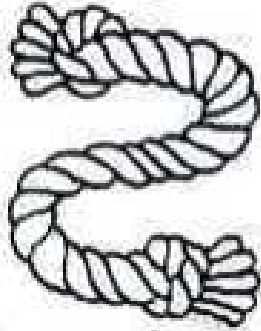

soga

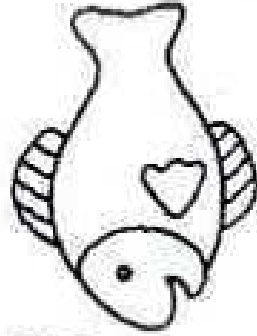

salmón

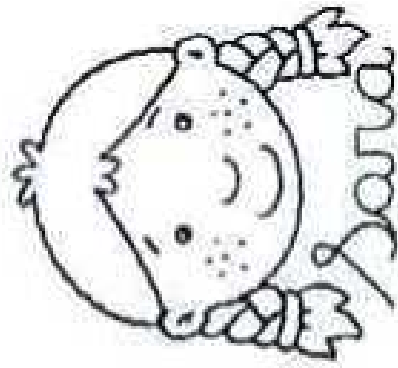

Sara

- DELINEA Y COMPLETA CADA RENGLÓN.



Copyright © Probar.es

- ESCRIBE EN CURSIVA LAS LETRAS QUE FALTAN.
- DELINEA CADA PALABRA MIENTRAS LA LEES EN VOZ ALTA.
- COLOREA LOS OBJETOS CUYOS NOMBRES TIENEN TRES SILABAS.

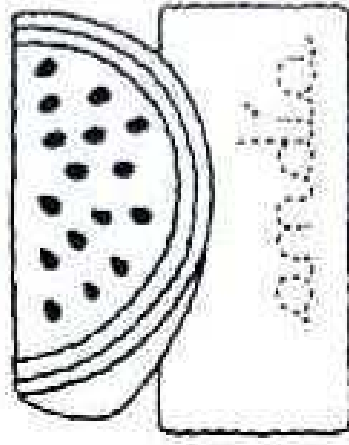
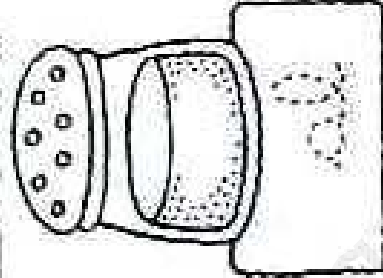
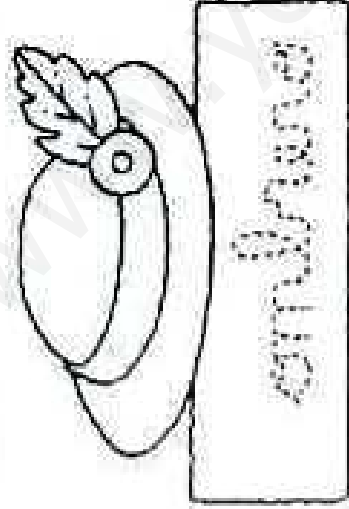
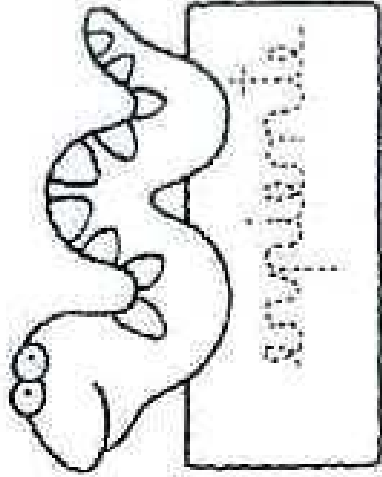
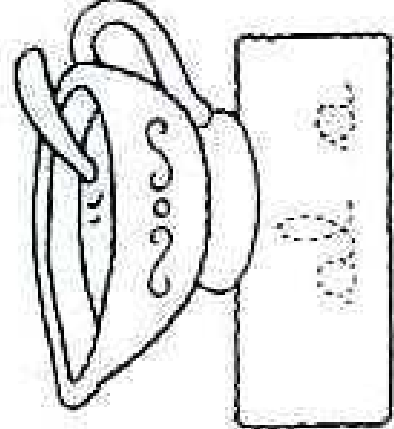
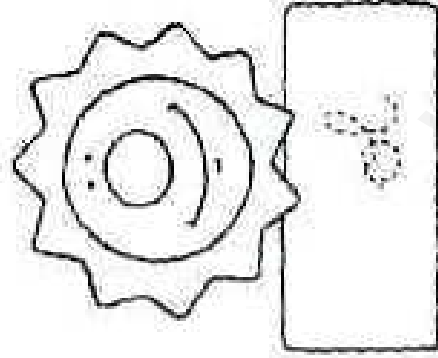

• TRAZA LOS SALTOS DEL SALMÓN.

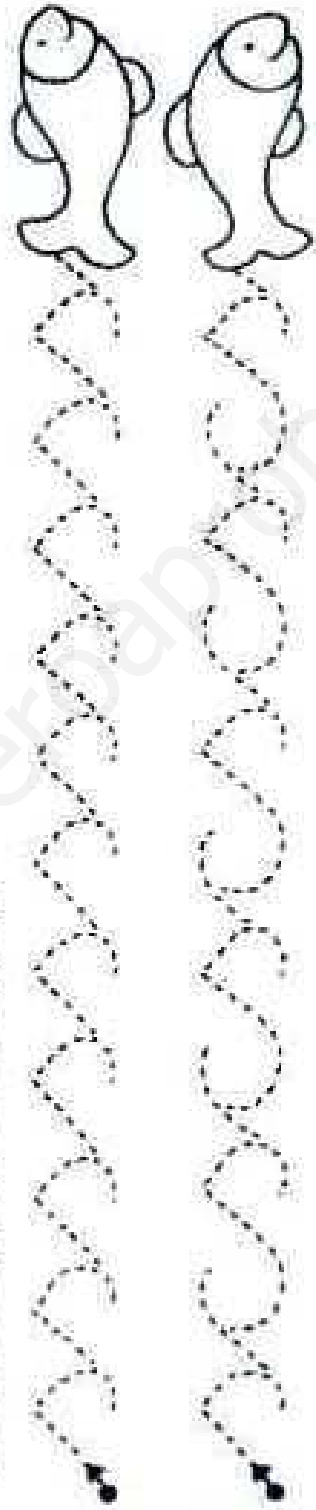

• AGREGA LA "S" SEGUN CORRESPONDA.

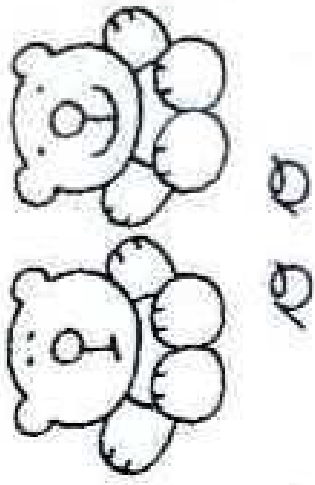
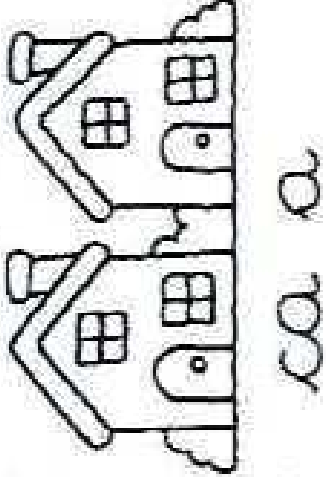
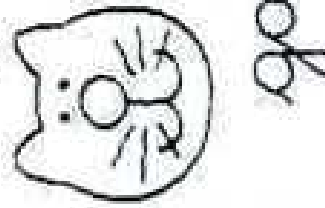
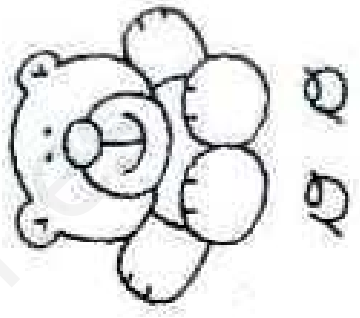
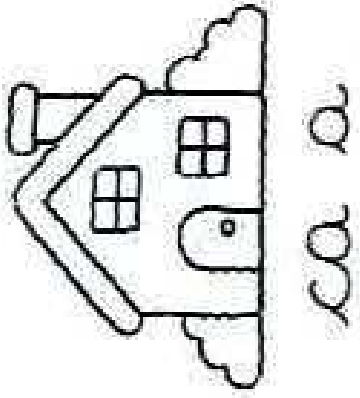
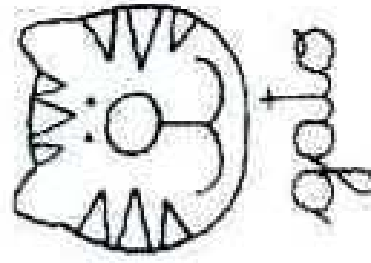

- RECORRE LAS LETRAS GRANDES CON TU DEDO (ÍNDICE).
- DECÓRALAS COMO MÁS TE GUSTE.

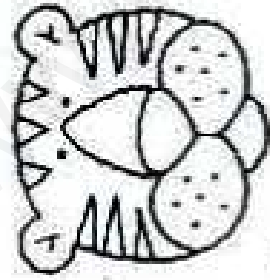
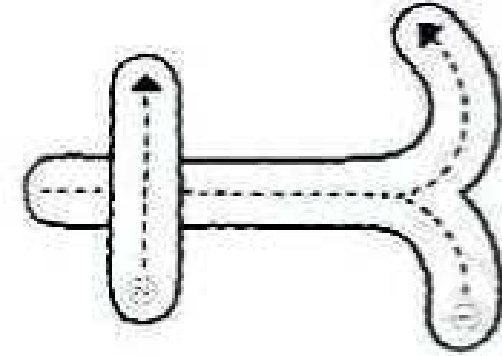

tigre

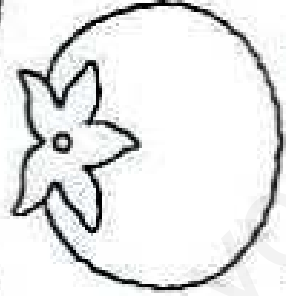
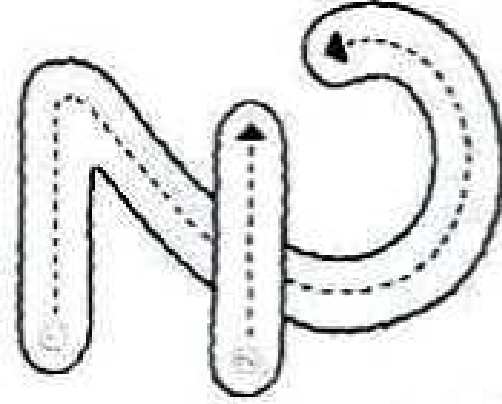

tomate

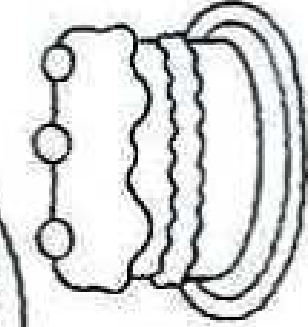

torta

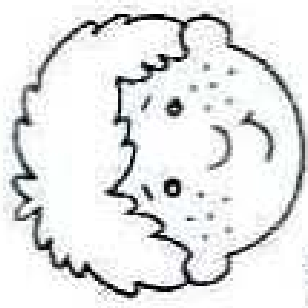

zomáis

t

t

z

T

- DELINEA Y COMPLETA CADA RENGLÓN.

t

t

ta

te

ti

to

tu

t t

z z

a b c d e f g h i j k l m n ñ o p q r s t u v w x y z

• COLOREA LOS OBJETOS QUE COMIENZAN CON LA LETRA "T" SIGUIENDO EL RECÓRRIDO DEL TREN HASTA LA LLEGADA.

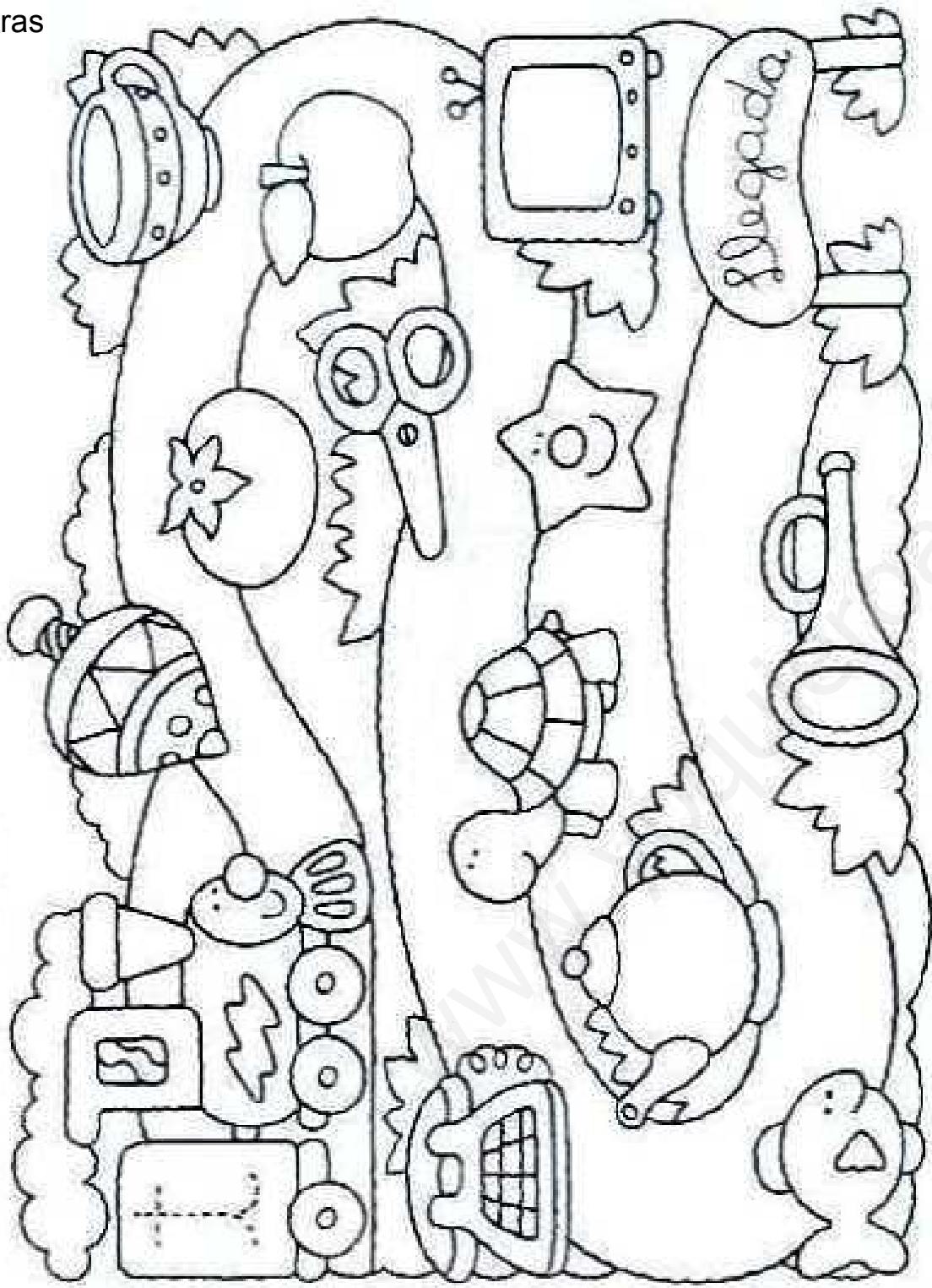

• ¿QUIÉN CONDUCE EL TREN? ES UN ANIMAL QUE COMIENZA CON "T". COLORÉALO.

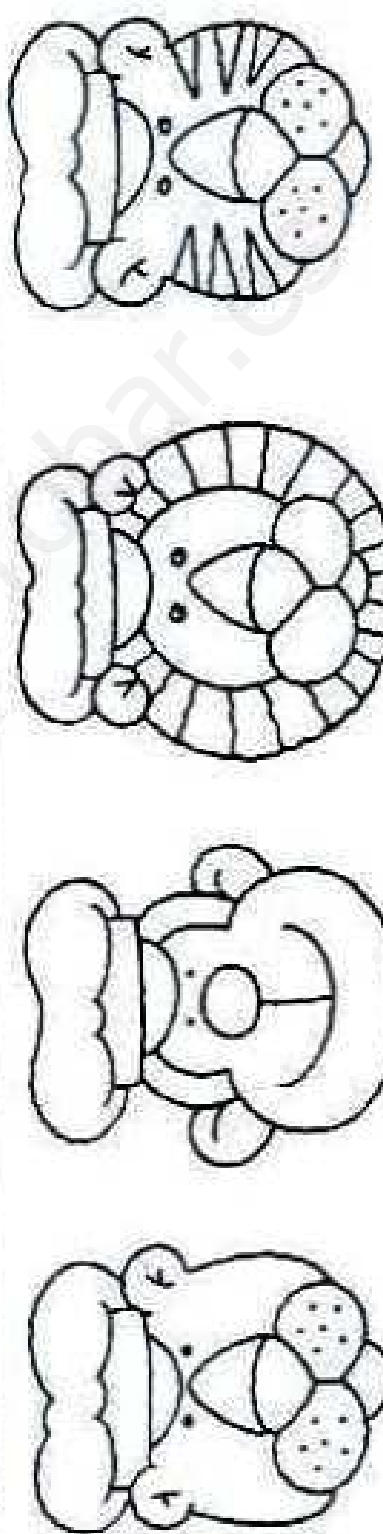

• DIBUJA EN LA LÍNEA LAS PALABRAS QUE COMIENZAN CON "T":

• DELINEA Y COPIA ESTAS PALABRAS:

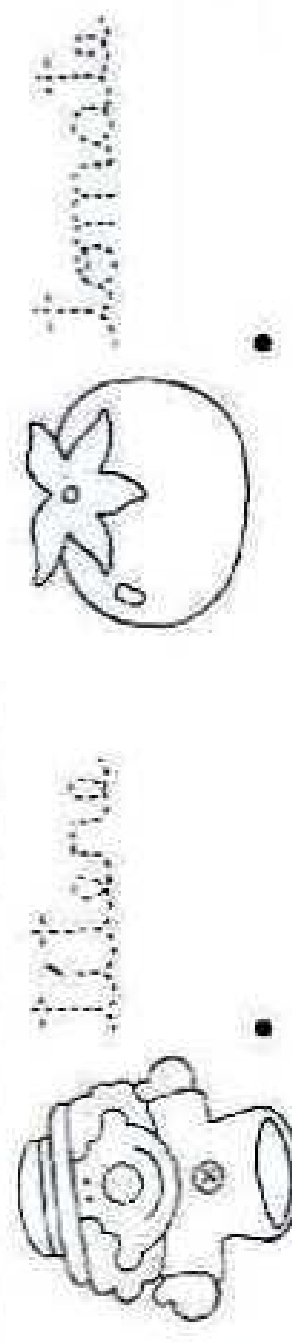

- RECORRE LAS LETRAS GRANDES CON TU DEDO INDICE.
- DECORALAS COMO MAS TE GUSTE.

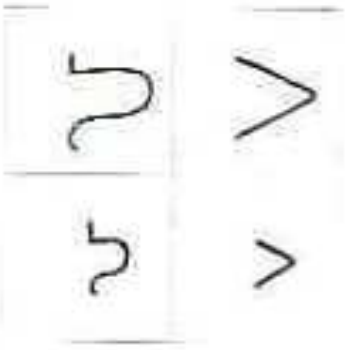
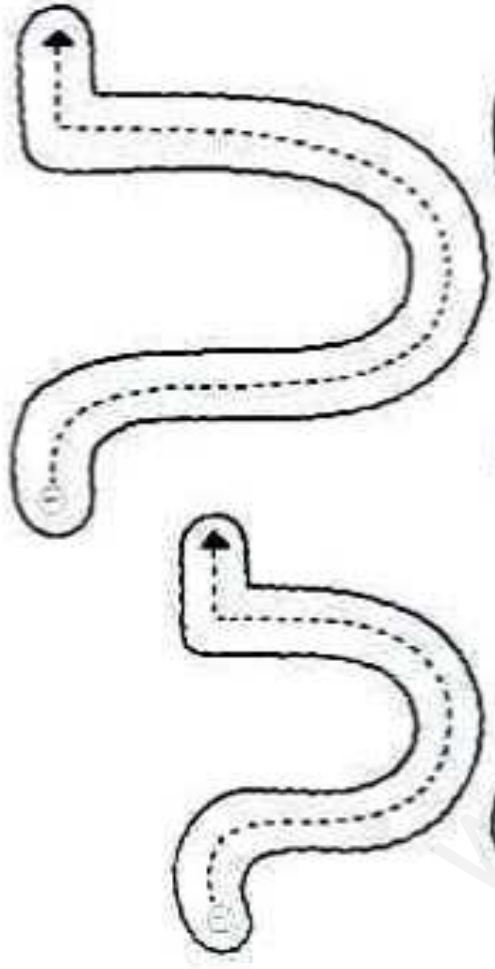

vela

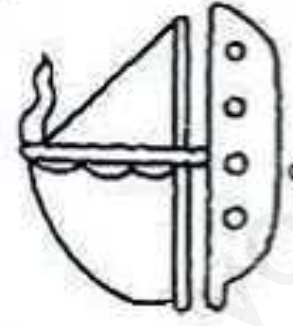

vclero

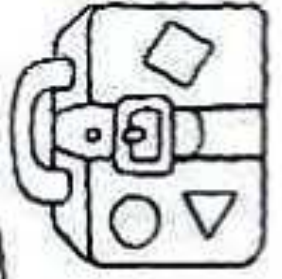

valija



Vera

- DELINEA Y COMPLETA CADA RENGLÓN.



v

va

ve

vi

vo

vu



Www.Papaprobar.es

• SI ESCRIBES LA LETRA INICIAL DE CADA OBJETO TE QUEDARÁN FORMADAS DOS PALABRAS QUE COMIENZAN CON "V".

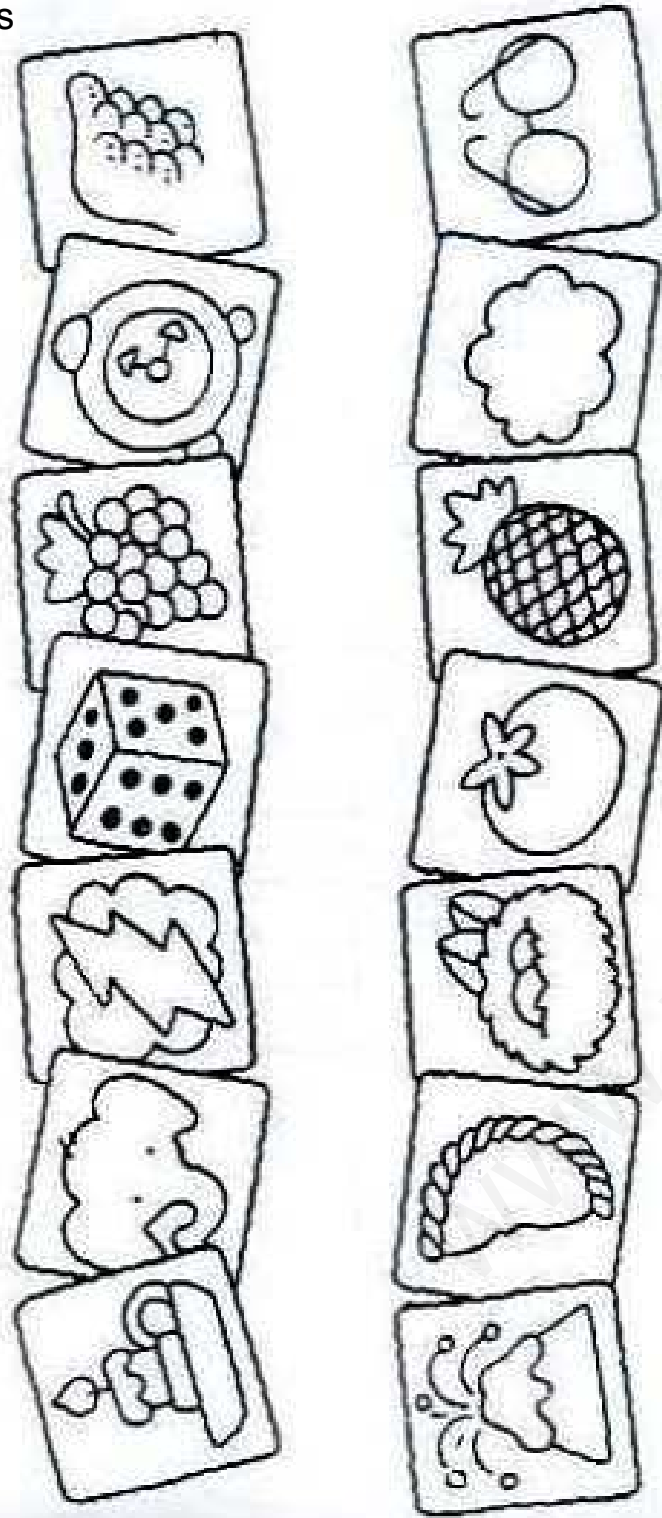

• TRAZA CON LÁPIZ DE COLOR EL VUELO DE LA MARIQUITA.

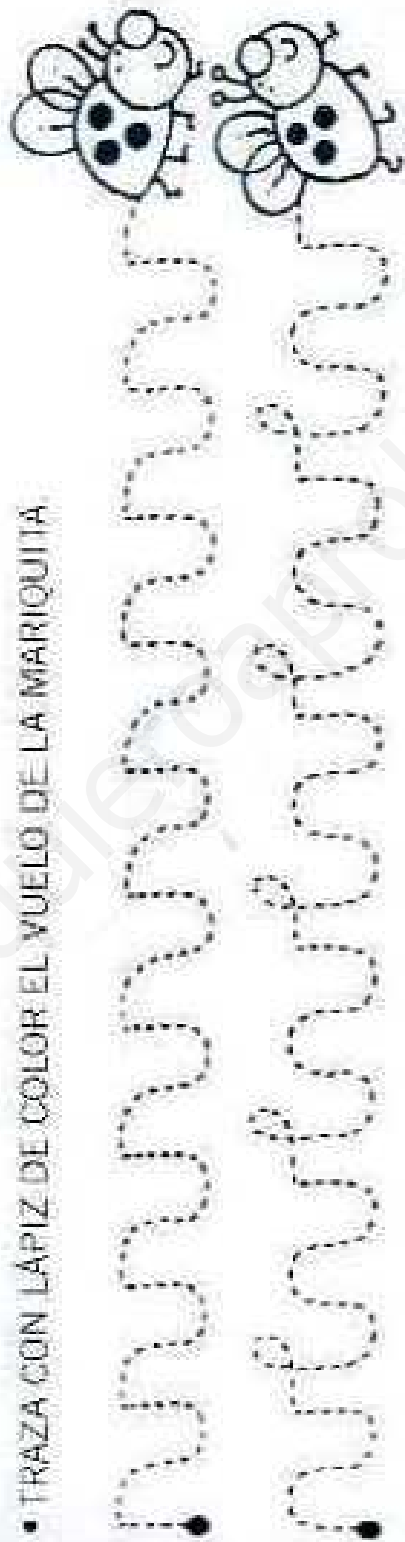

• DELINEA Y COPIA ESTAS PALABRAS MIENTRAS LAS LEES EN VOZ ALTA.

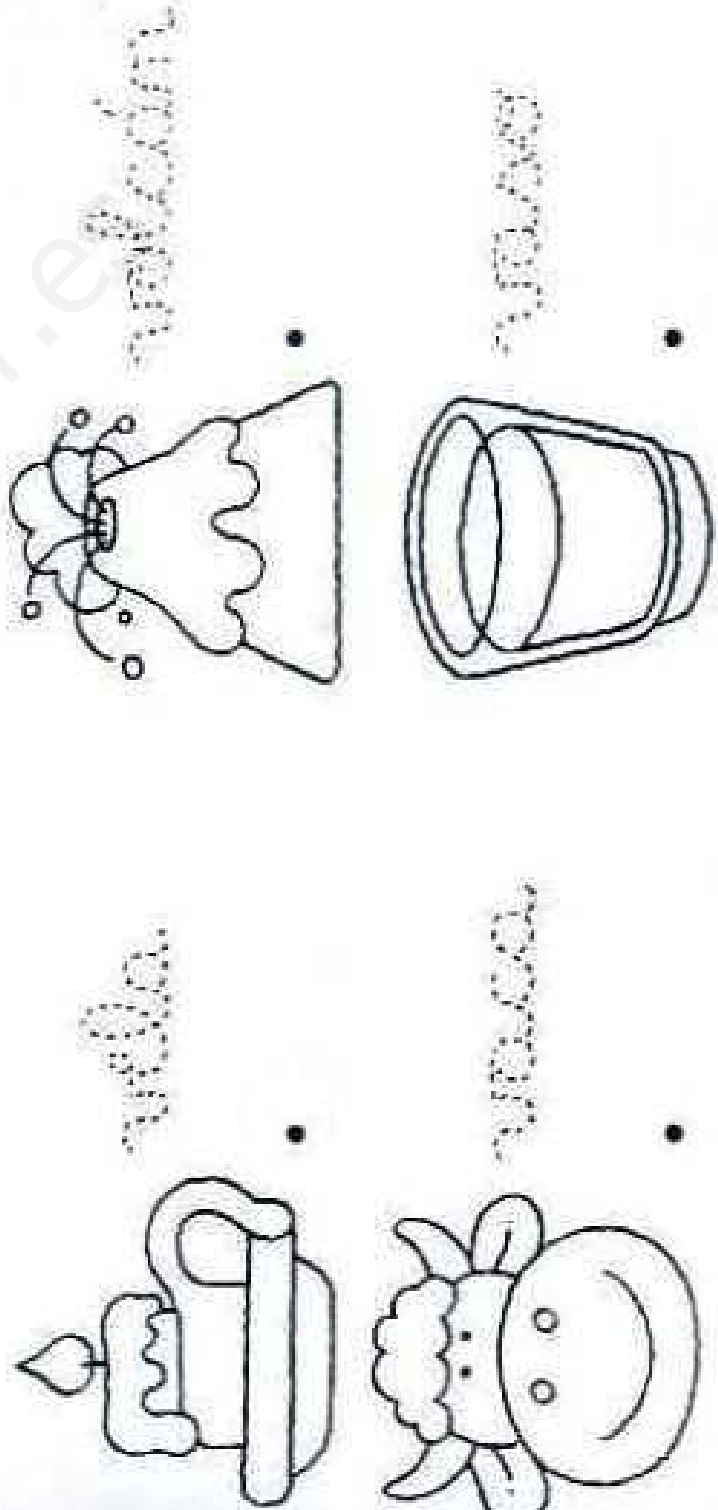

- EN ESTA BOLSA GIGANTE DESCUBRE Y DELINEA CON COLOR CADA LETRA DEL ABECEDARIO EN ORDEN ALFABÉTICO.
- ¡JUEGO CÓPIA EN LOS RENGONES DE ABAJO!

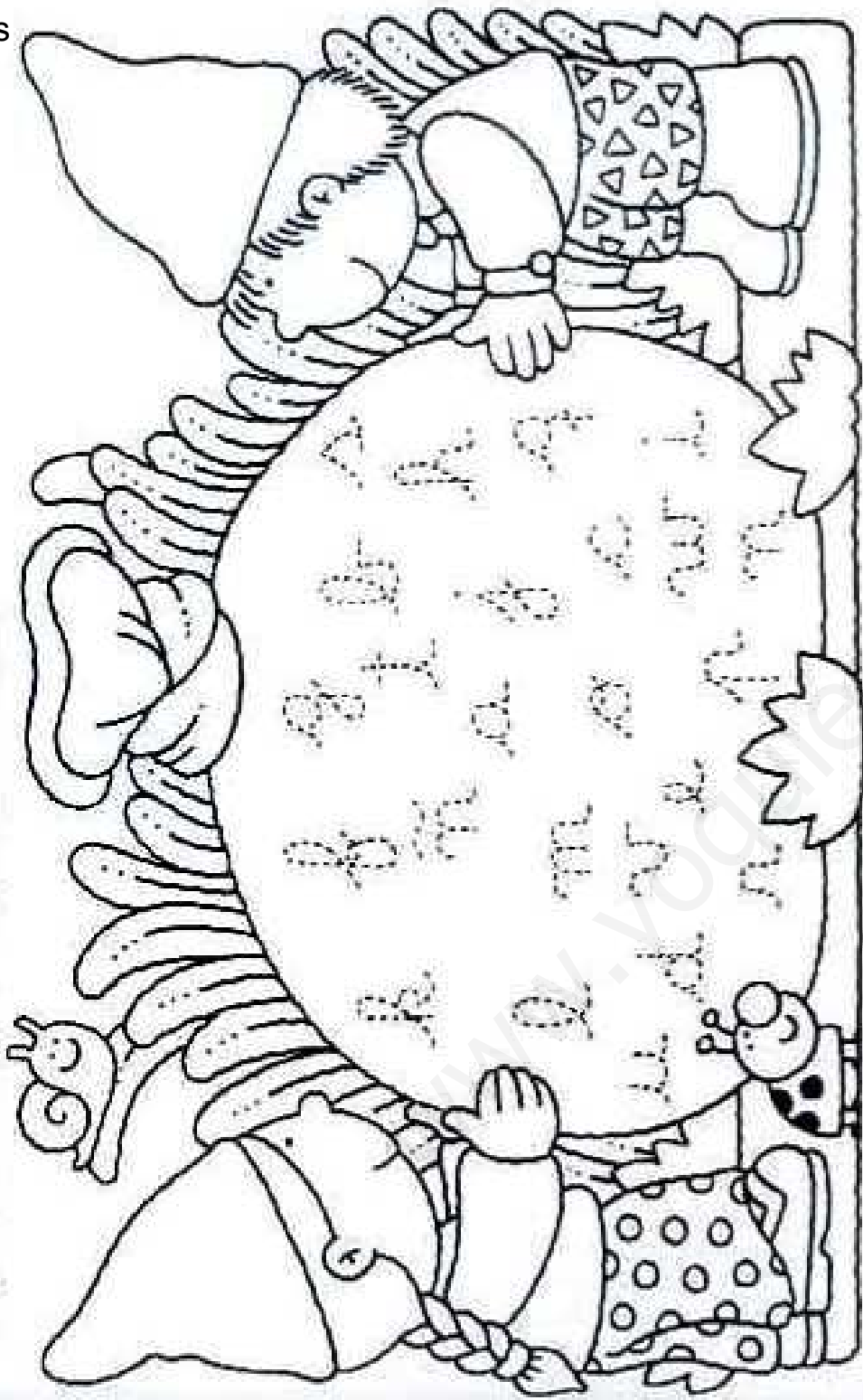

z k x

- COLOREA LAS REGIONES QUE TIENEN LA LETRA "w" EN SU INTERIOR.

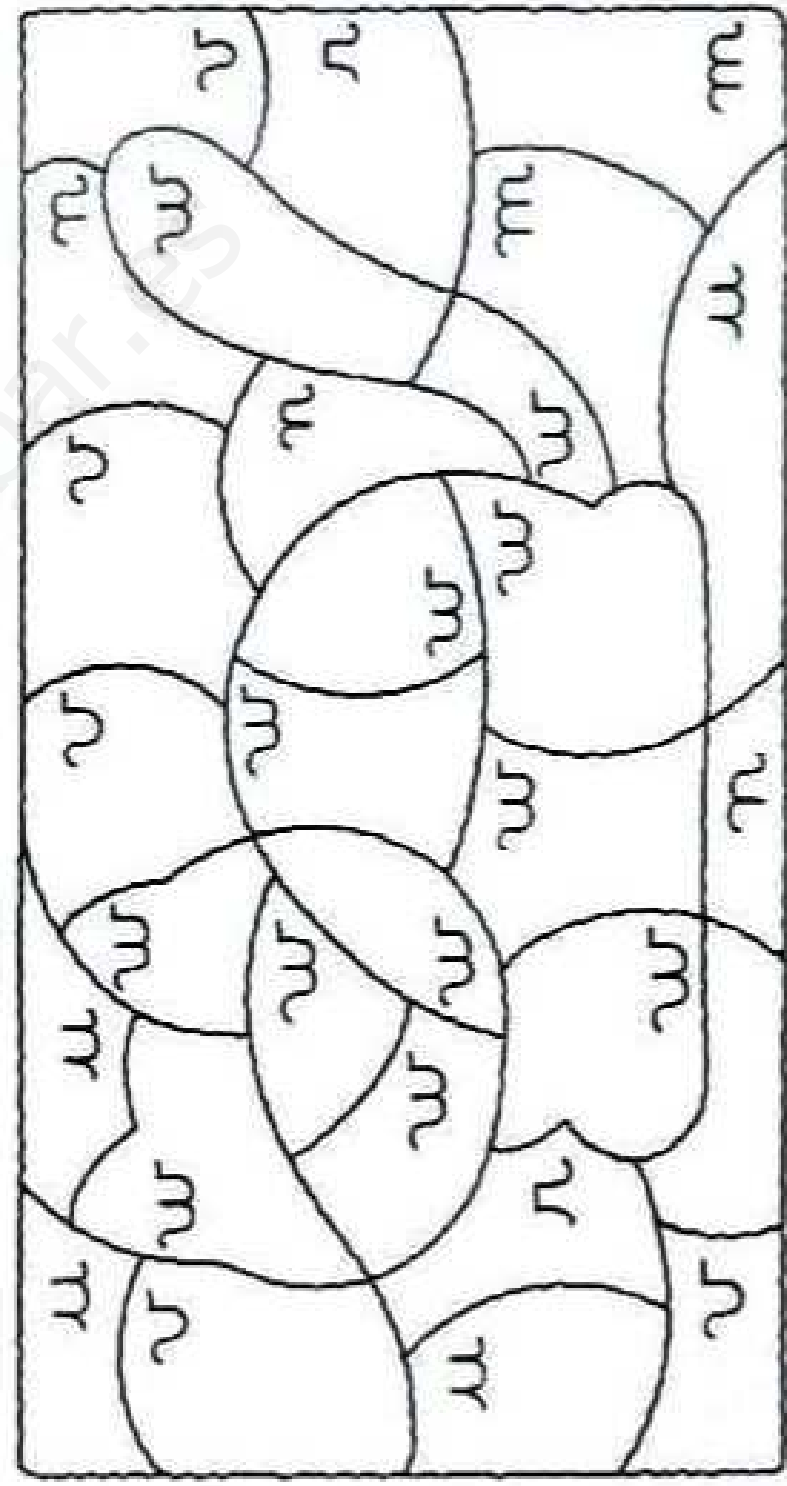

- RECORRE LAS LETRAS GRANDES CON TU DEDO ÍNDICE.
- DECÓRALAS COMO MÁS TE GUSTE.

a b c d e f g h i j k l m n ñ o p q r s t u v w x y z

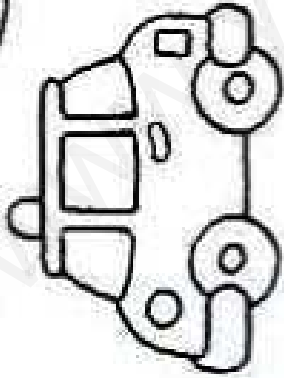
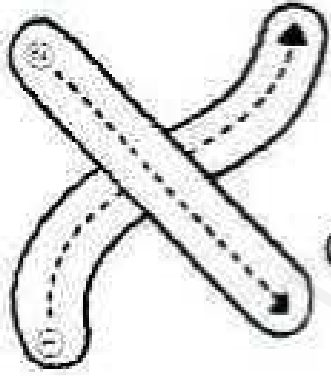

taxi

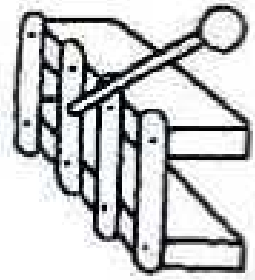
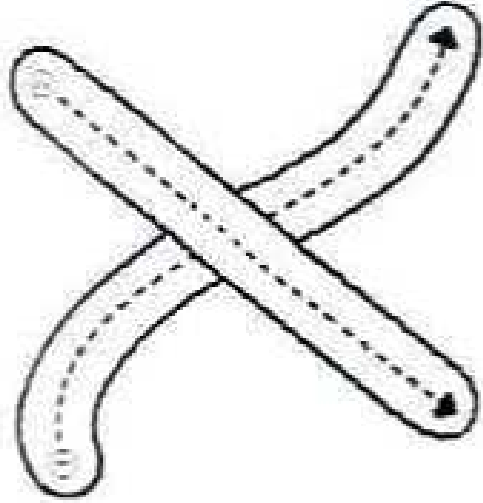

xilofón saxos

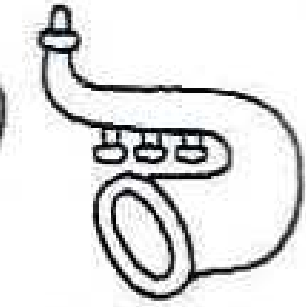

Xavier

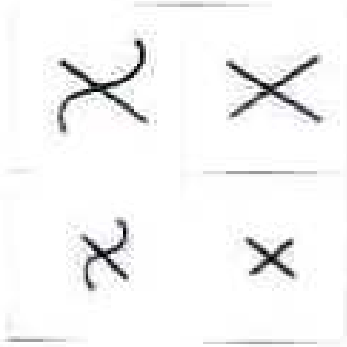

- DELINEA Y COMPLETA CADA RENGLÓN.

x

x

xa

xe

xi

xe

mx



Copyright © Aprobar.es

• UNE CON UNA LÍNEA LAS DOS PARTES DEL PERRO QUE CORRESPONDEN PARA

FORMAR PALABRAS CON "X".

• LEE EN VOZ ALTA CADA PALABRA Y REPASA LAS "X" CON ROJO.

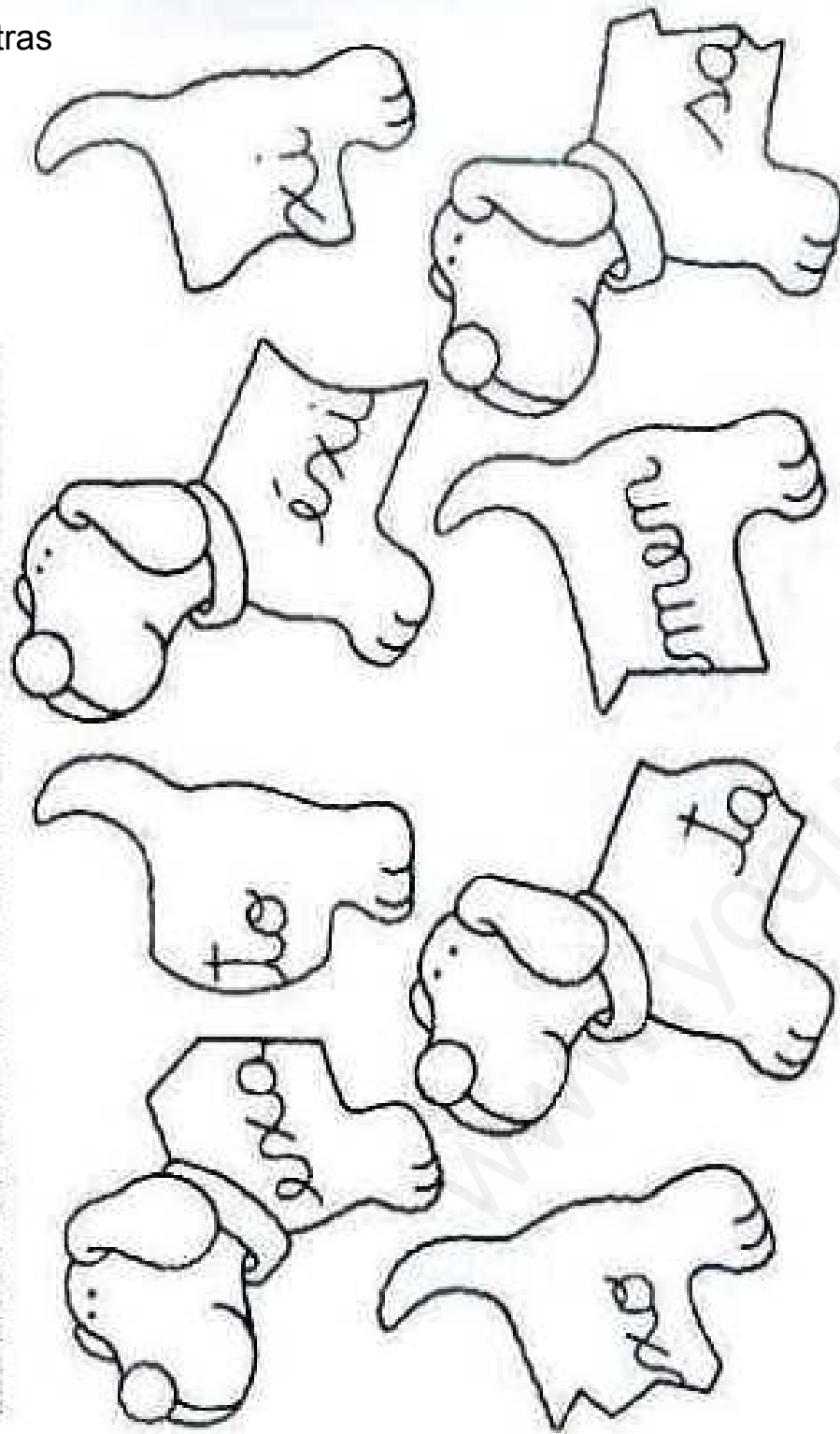

• COLOCA UNA LETRA EN CADA ABEJITA SIGUIENDO EL ORDEN DEL ABECEDARIO.

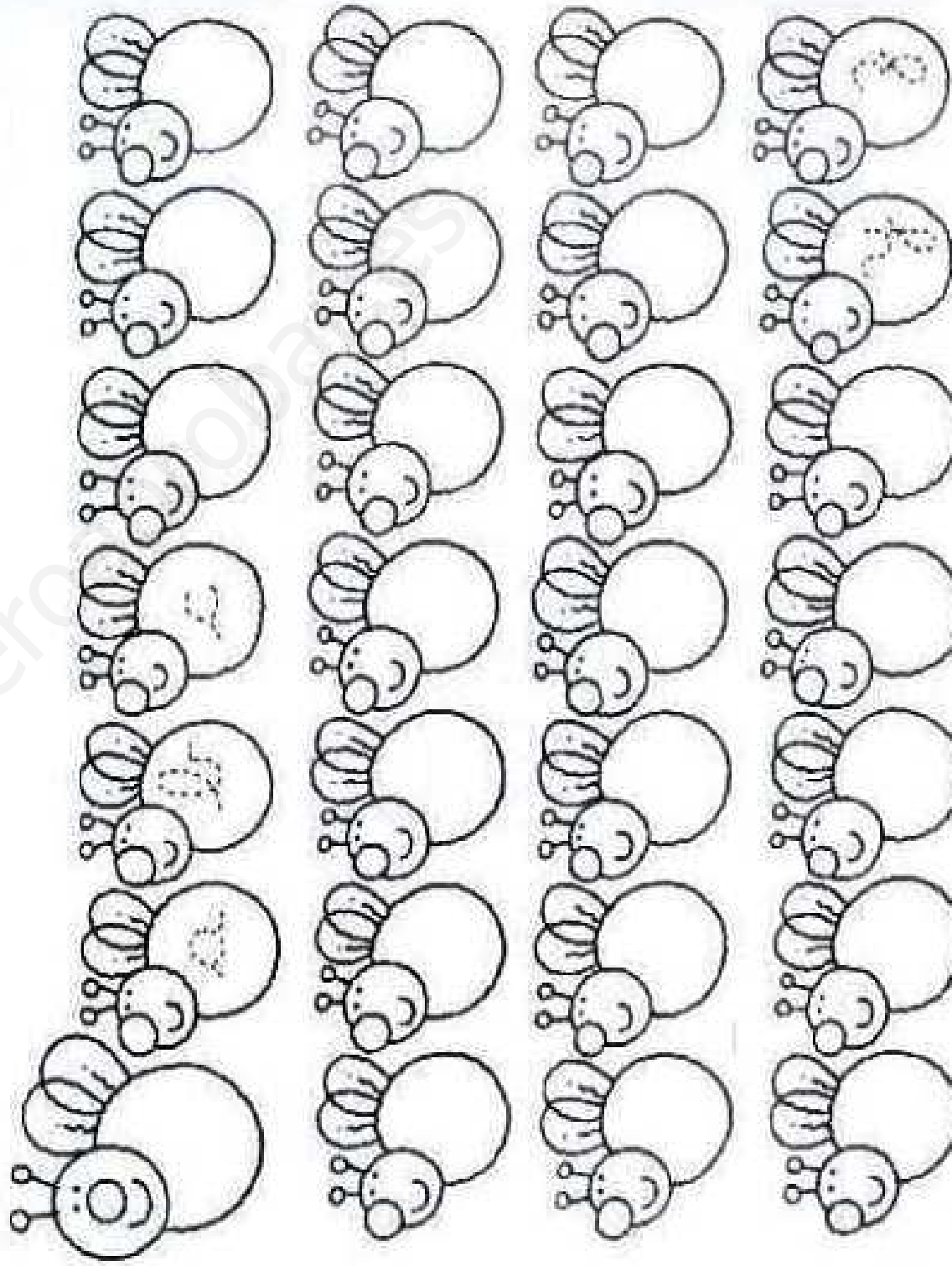

- REPASA CON LÁPIZ ROJO EL RECORRIDO CORRECTO QUE DEBE SEGUIR EL MONO PARA LLEGAR AL YOYÓ SIGUIENDO EL ORDEN DEL ABECEDARIO.
- DELINEA LAS DEMÁS LETRAS CON LÁPIZ VERDE.

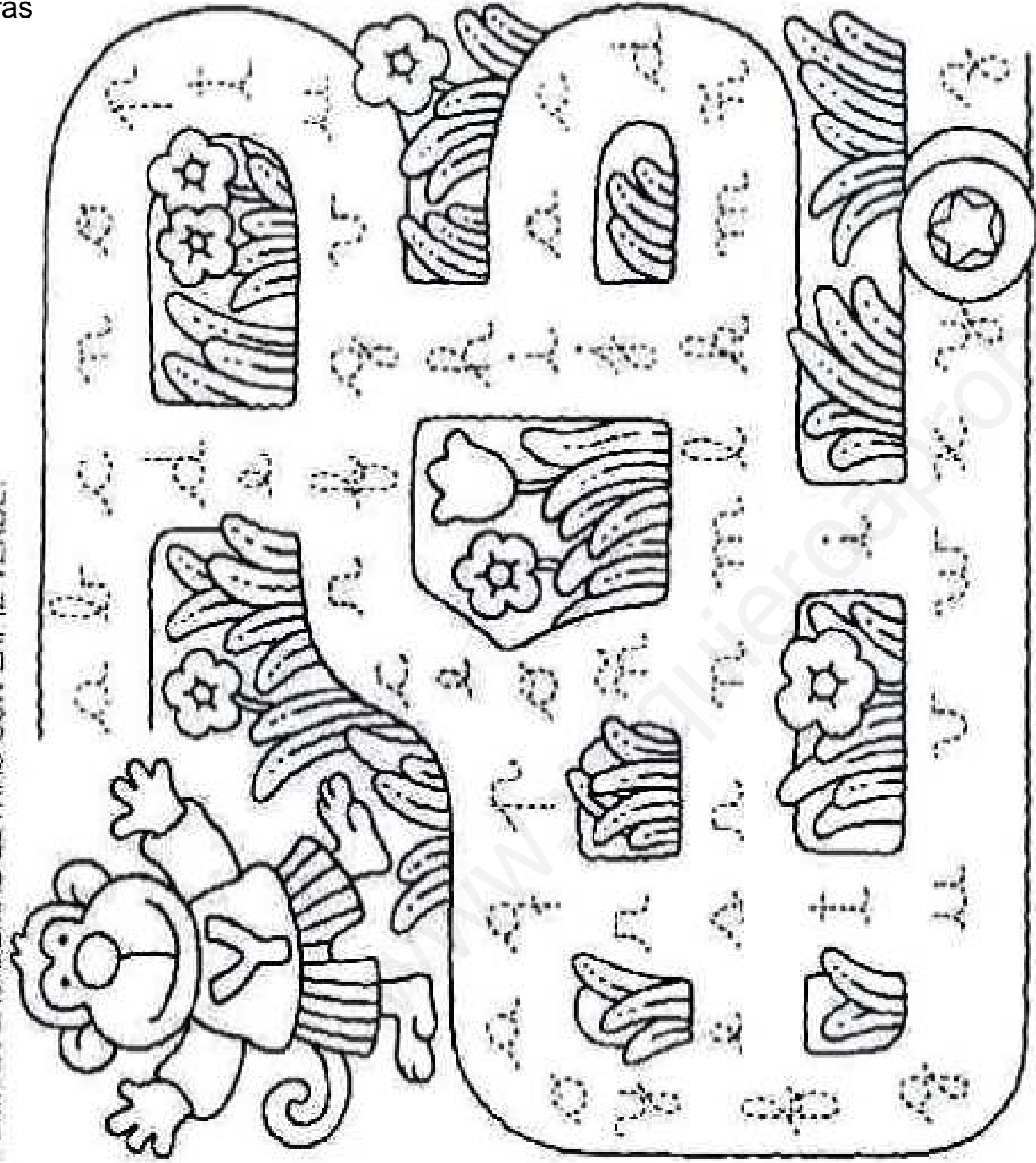

- ESCRIBE ESTAS PALABRAS EN LETRA CURSIVA.

YUYOOS

YEGUA

YELMO

- RECORRE LAS LETRAS GRANDES CON TU DEDO ÍNDICE.
- DECÓRALAS COMO MÁS TE GUSTE.

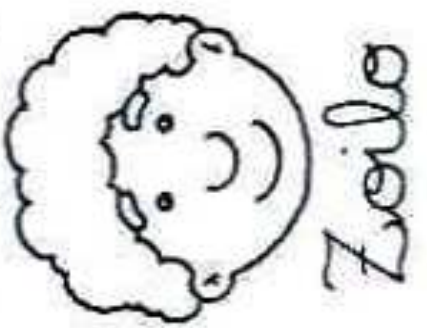
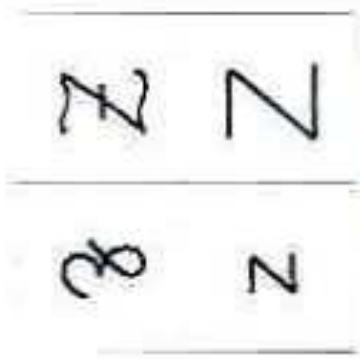
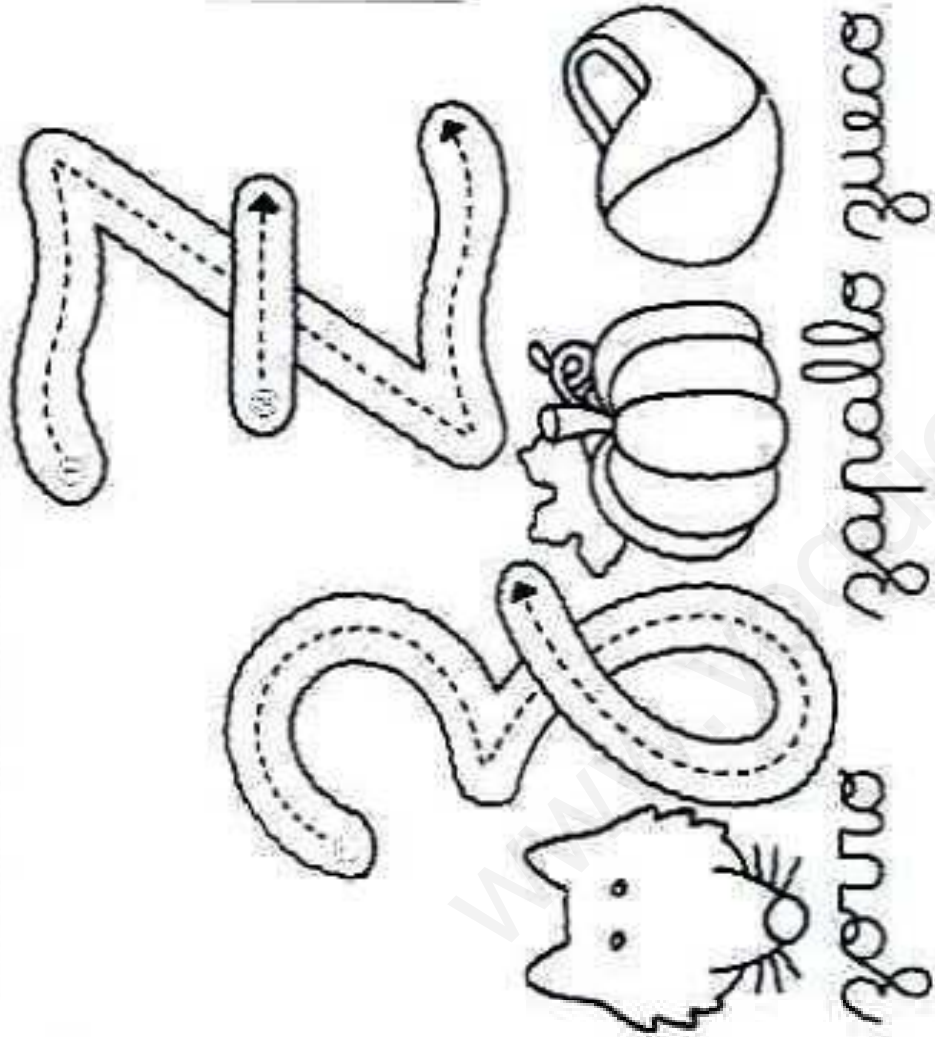

Zaida

zorro zapallo zueca

- DELINEA Y COMPLETA CADA RENGLÓN.

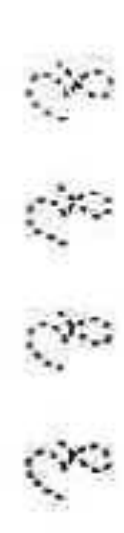

www.probar.es

- CADA UNO DE LOS CHICOS FORMA UNA PALABRA CON SU COLLAR. UTILIZA UN COLOR DIFERENTE PARA DELINEAR LAS LETRAS DE CADA COLLAR.
- DELETREA EN VOZ ALTA CADA PALABRA.

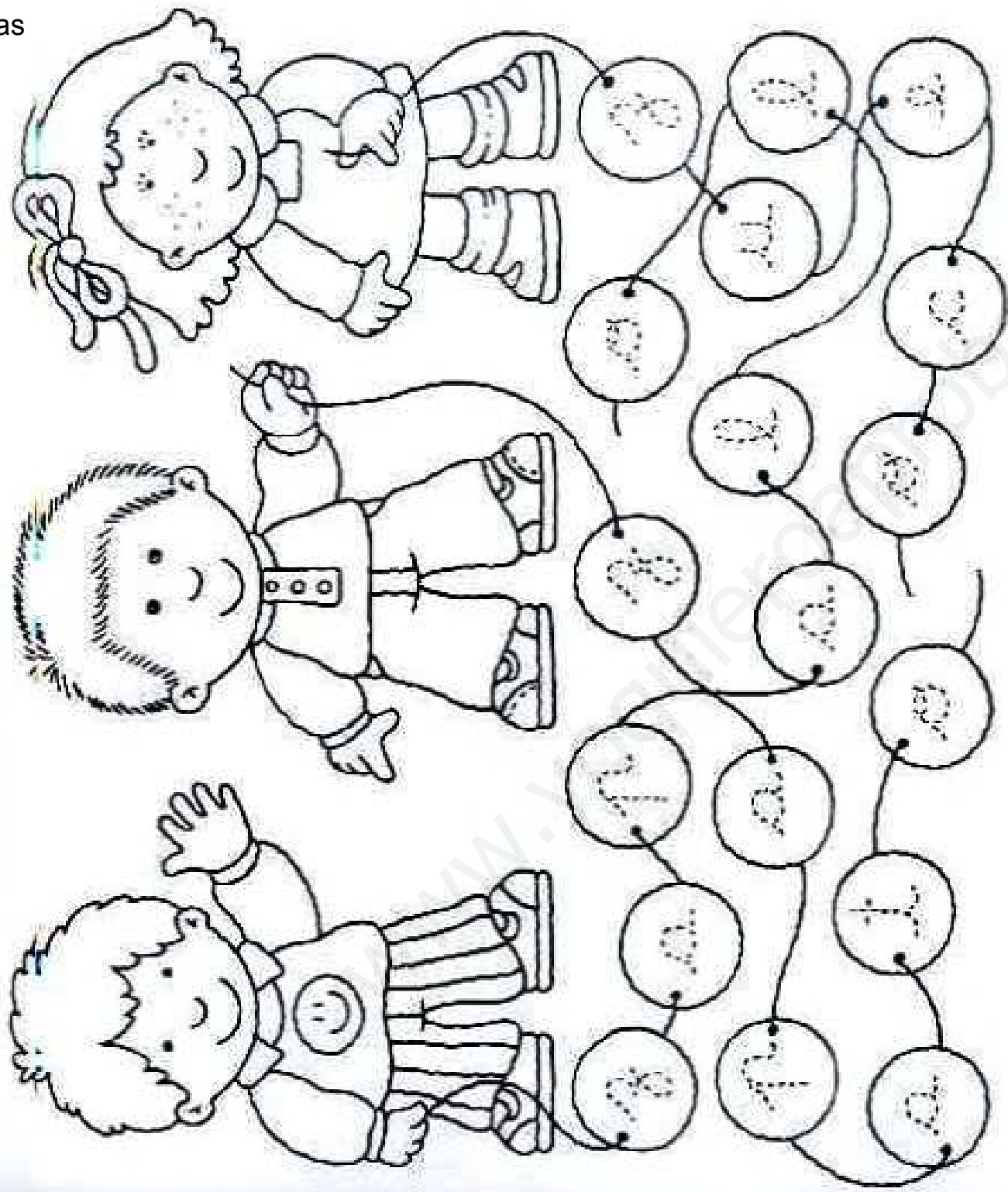

- DELINEA ESTAS PALABRAS MIENTRAS LAS LEES EN VOZ ALTA.
- COLOREA EL OBJETO QUE TIENE CUATRO SILABAS.

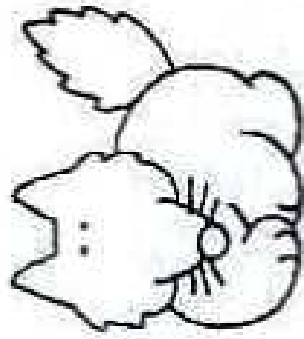

gatos

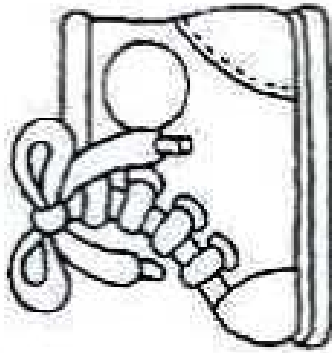

zapatos

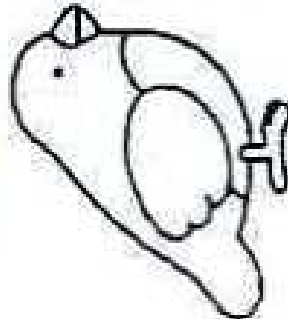

ave

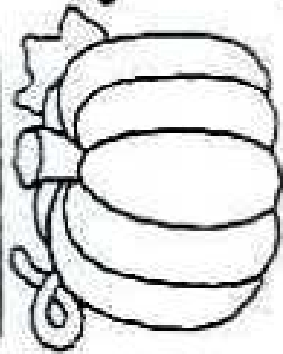

zapato

- DELINEA CADA LETRA MIENTRAS LA REPITES EN VOZ ALTA.
- UNE CON UNA LÍNEA CADA LETRA CON EL DIBUJO CORRESPONDIENTE.
- COLOREA LAS IMÁGENES.

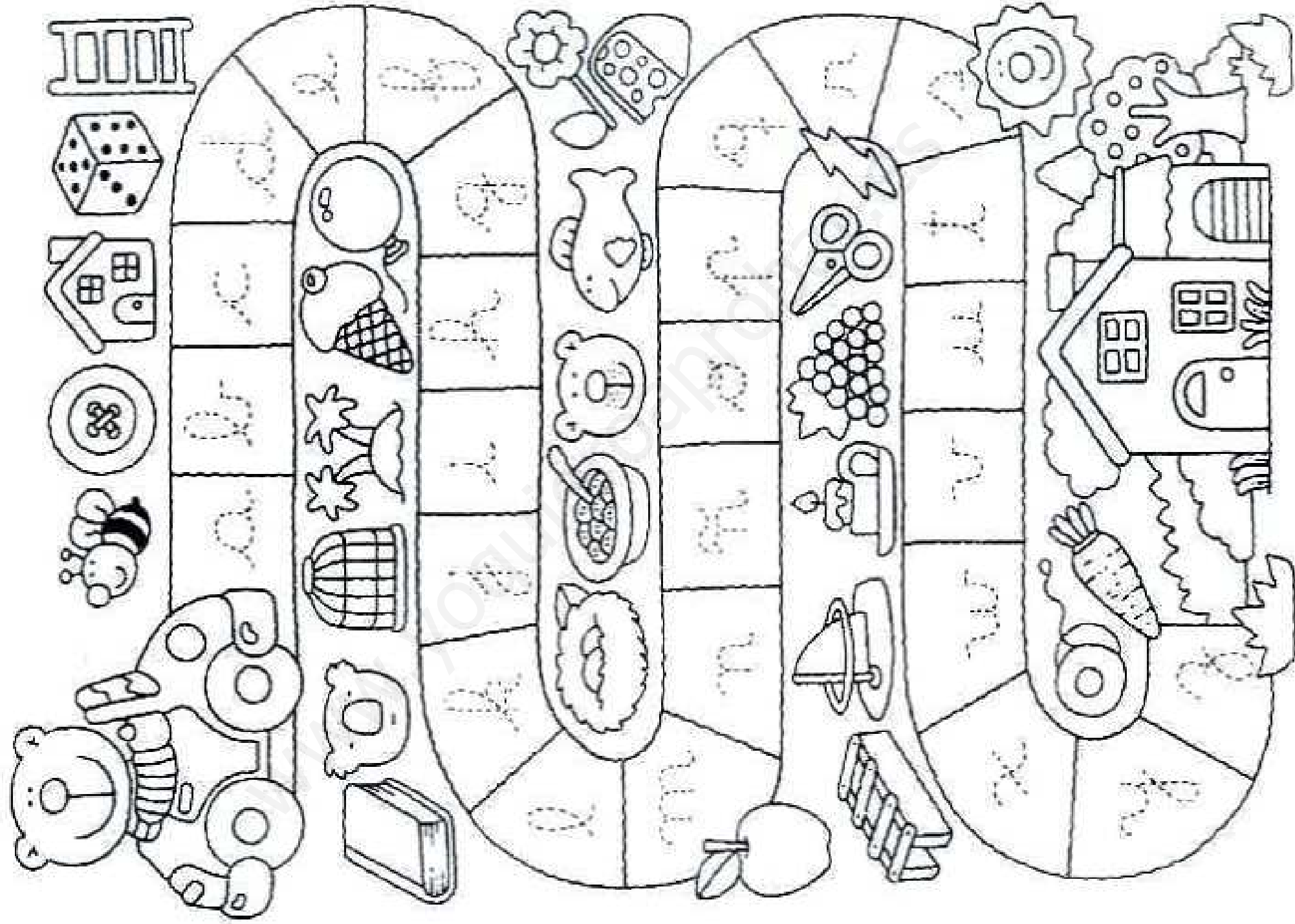

TRANSCRIBE CADA LETRA EN CURSIVA MINÚSCULA Y MAYÚSCULA.
COLOREA LAS LETRAS DE IMPRENTA.
MEMORIZA EN VOZ ALTA EL ABECEDARIO.

A B C D E F G H I

J K L M N O P Q R S

T U V W X Y Z

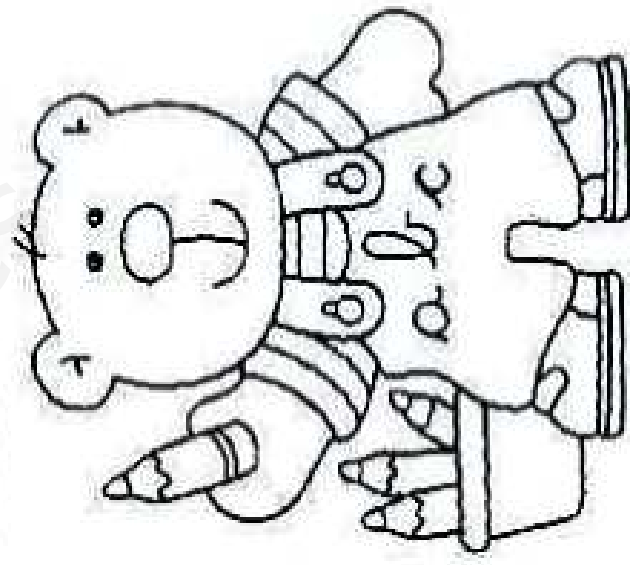

DELINEA CON COLOR LAS LETRAS.
DEBAJO DE CADA SILUETA ESCRIBE CORRECTAMENTE LA PALABRA FORMADA.

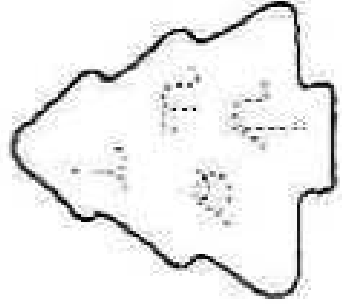

•

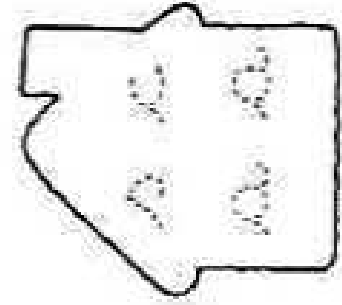

•

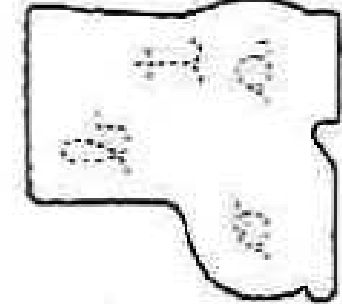

•

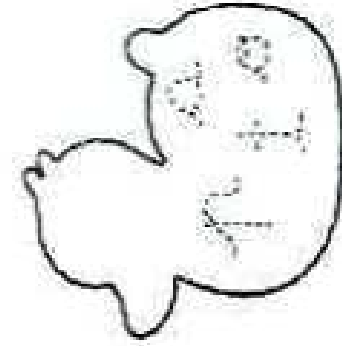

•

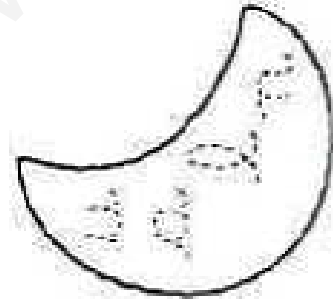

•

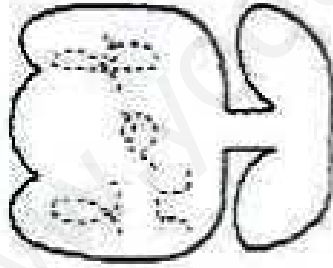

•

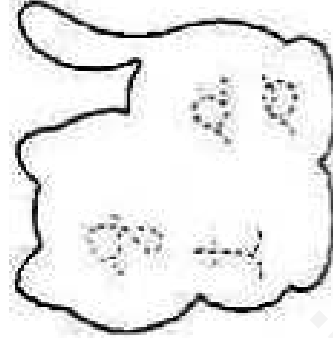

•



•

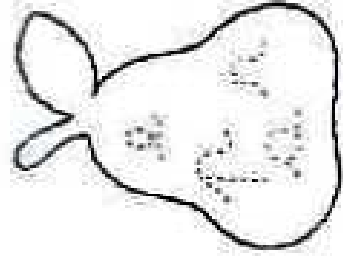

•



•

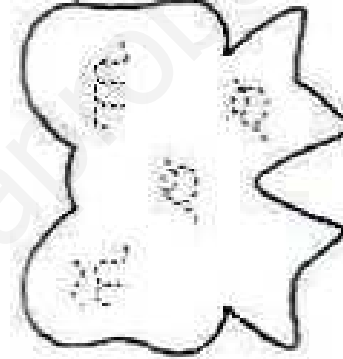

•

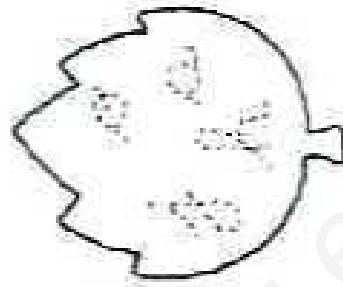

•

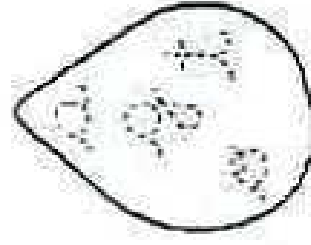

•

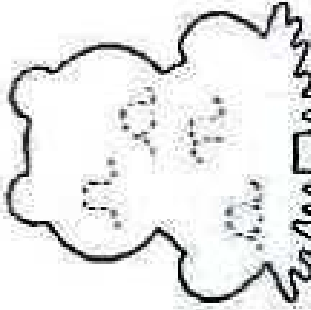

•

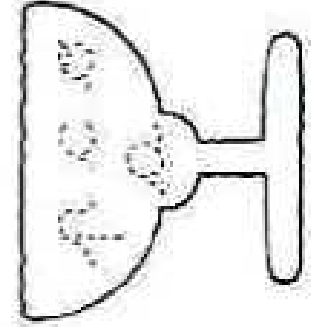

•

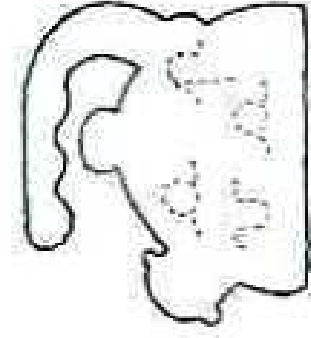

•

• DELINEA CON DISTINTOS COLORES LOS CIRCULOS.

• UNE CON UNA LINEA LOS PUNTOS SIGUIENDO EL ORDEN ALFABETICO Y FORMANDO EL TRAJE DEL PAYASO.

• COLOREA LA IMAGEN.

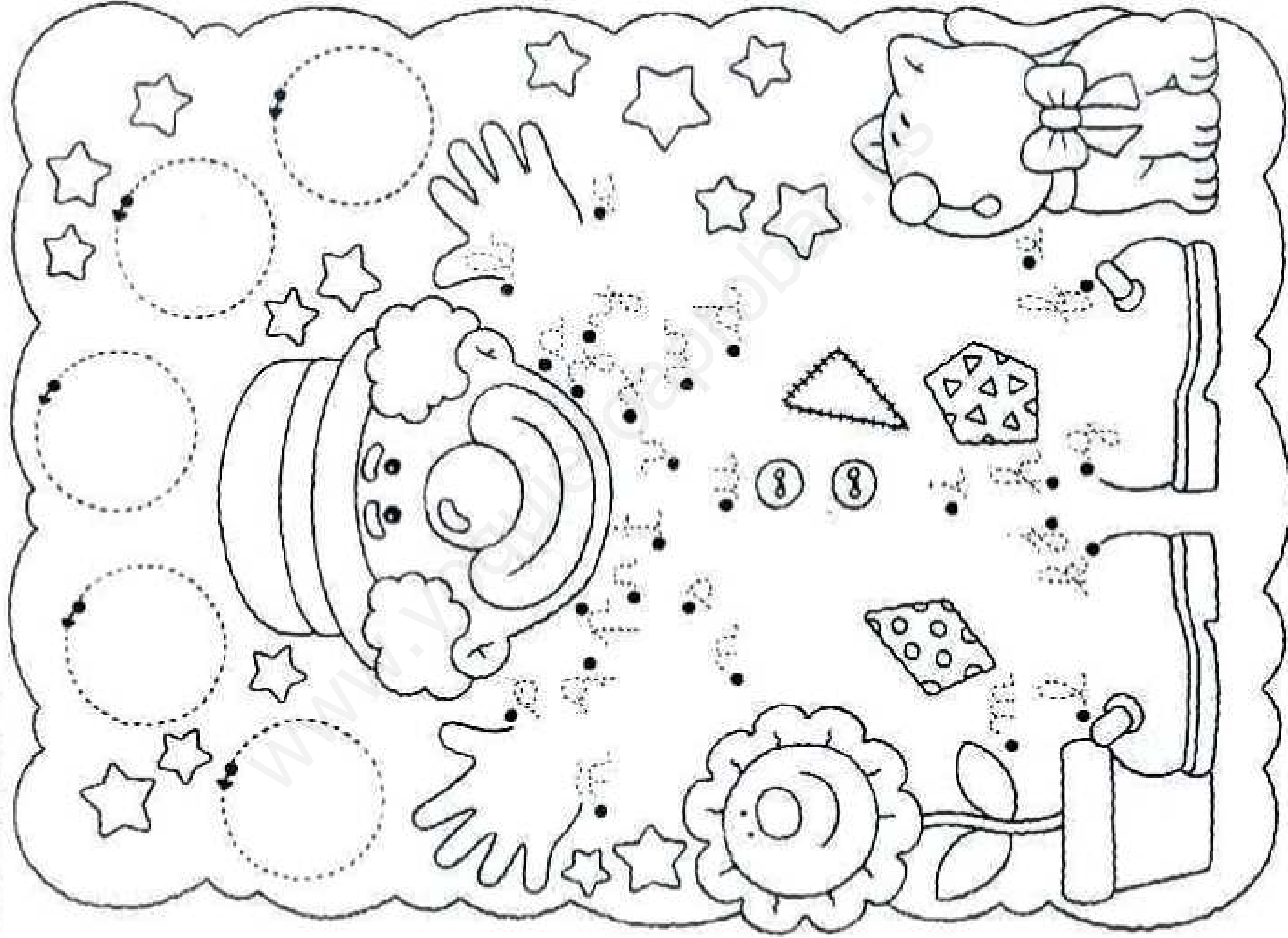

¡A ESCRIBIR NOMBRES PARA CADA CHICO!

- DELINEA CON ROJO LA LETRA MAYÚSCULA INICIAL Y COMPLETA CON EL NOMBRE QUE MÁS TE GUSTE.

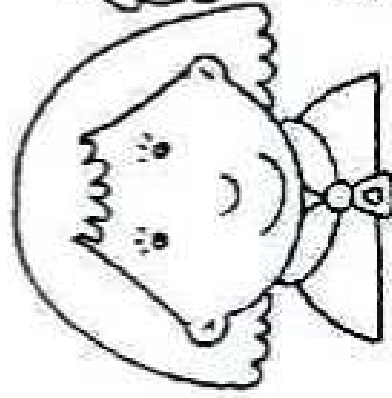

Q

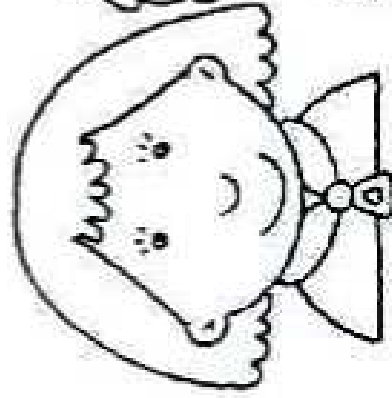

B

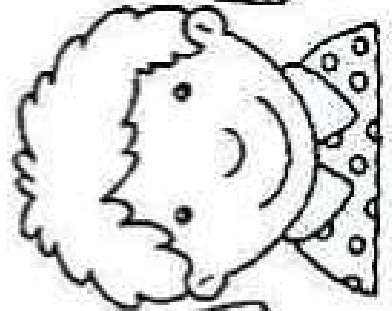

B

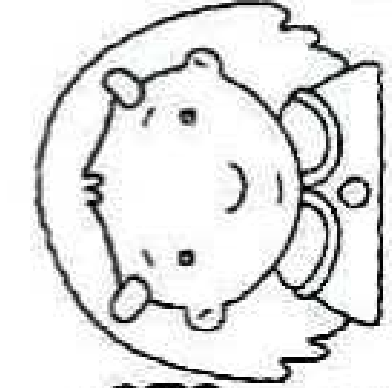

C

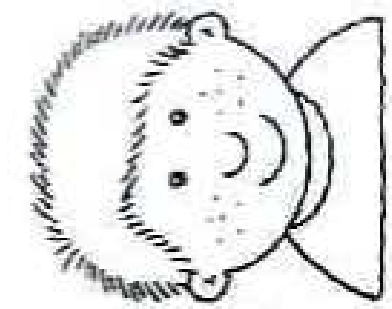

R

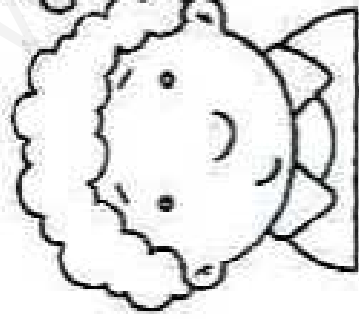

D

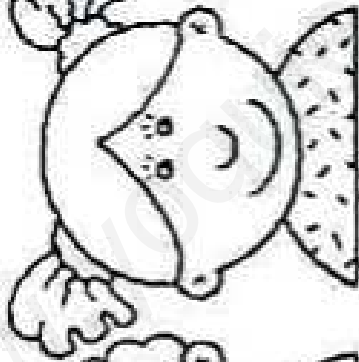

Z

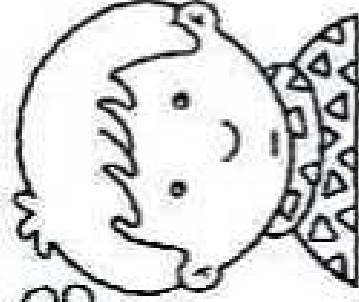

K

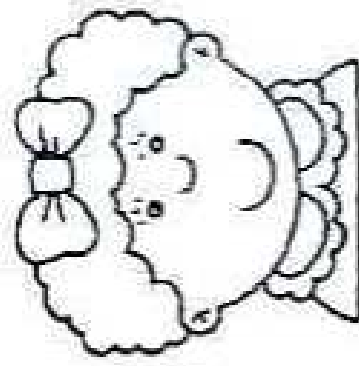

L

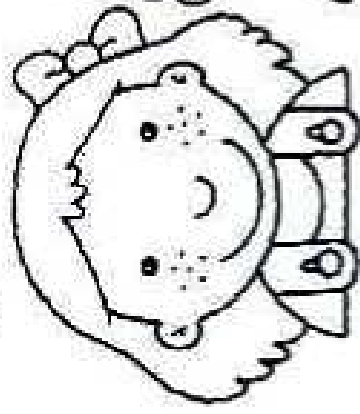

F

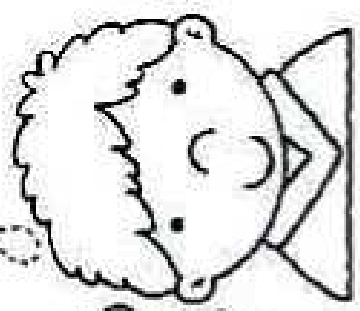

A

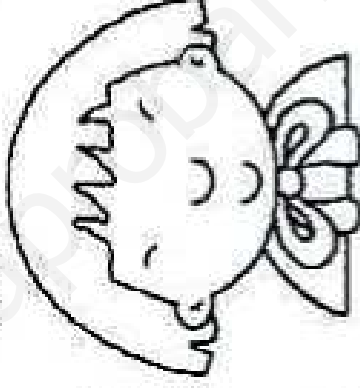

R

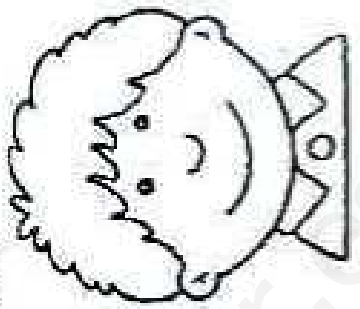

A

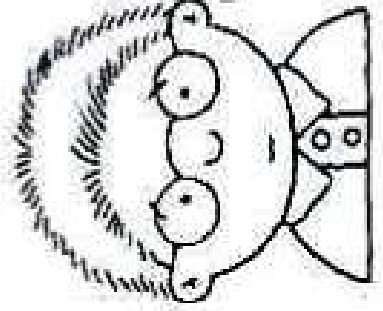

X

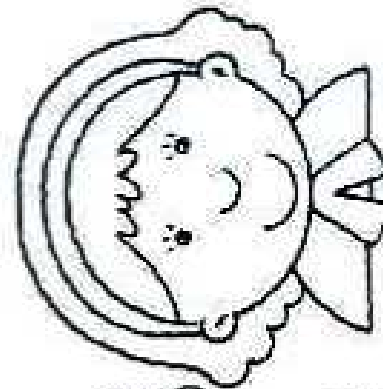

J

- COLOREA LOS DIBUJOS.
- DELINEA Y LEE EN VOZ ALTA LAS PALABRAS DE CADA RECUADRO.
- LUEGO RODEA CON COLORES LA QUE CORRESPONDE A LA FIGURA.

gato tigre gato

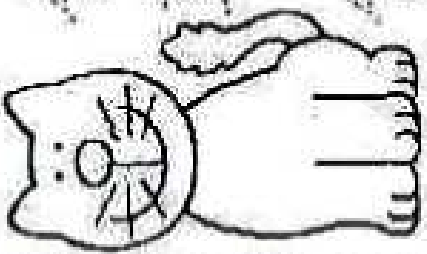

flor flor flor

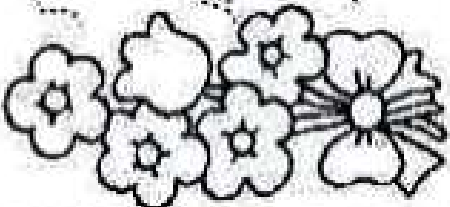

agua agua agua

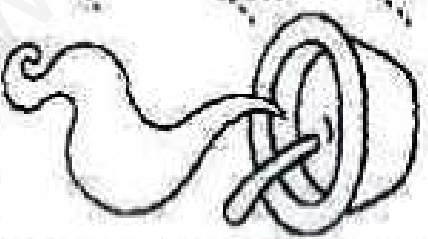

pez pez pez

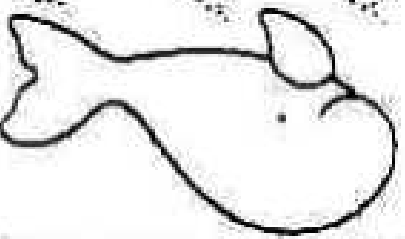

fruta fruta fruta



gota gota gota

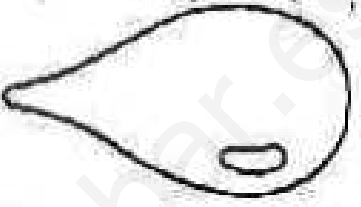

lana lana lana

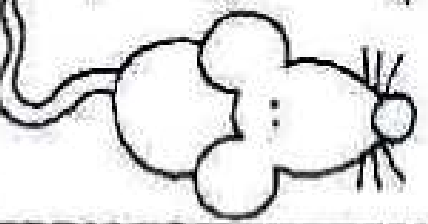

manzana manzana manzana

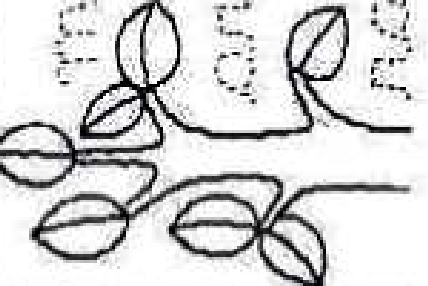

- SEPARA CON UNA LÍNEA DE COLOR UNA PALABRA DE OTRA.
- LEE Y DELINEA CADA PALABRA CON UN COLOR DIFERENTE.
- COLOREA LOS DIBUJOS.

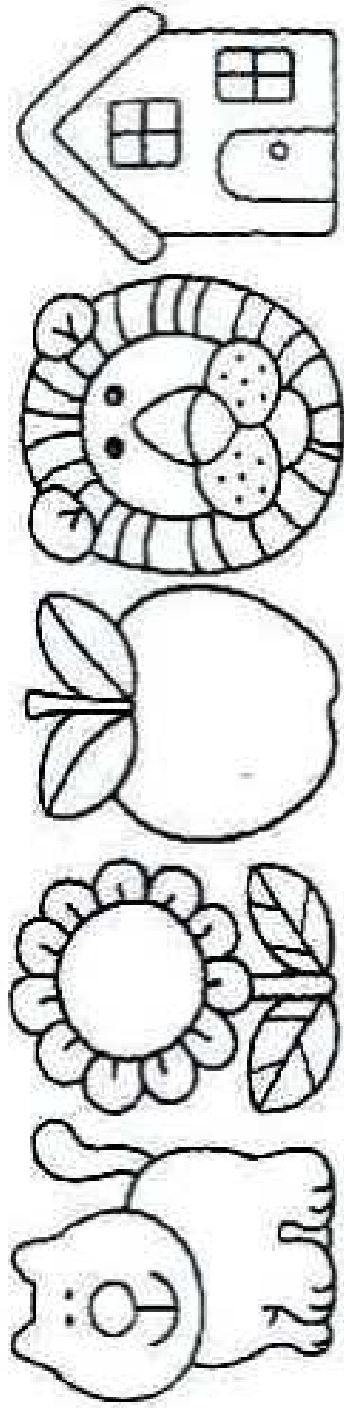

gato sol flor león casa

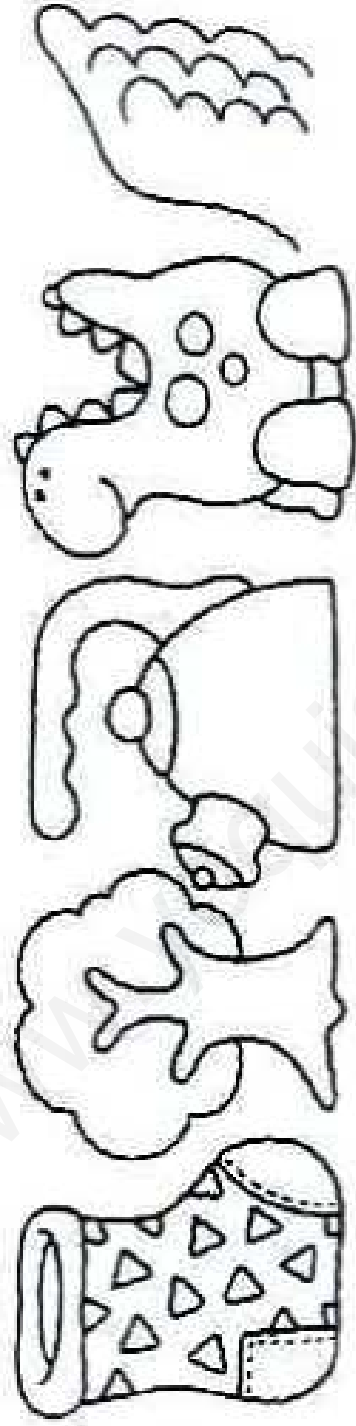

melón árbol tetera dinosaurio mano

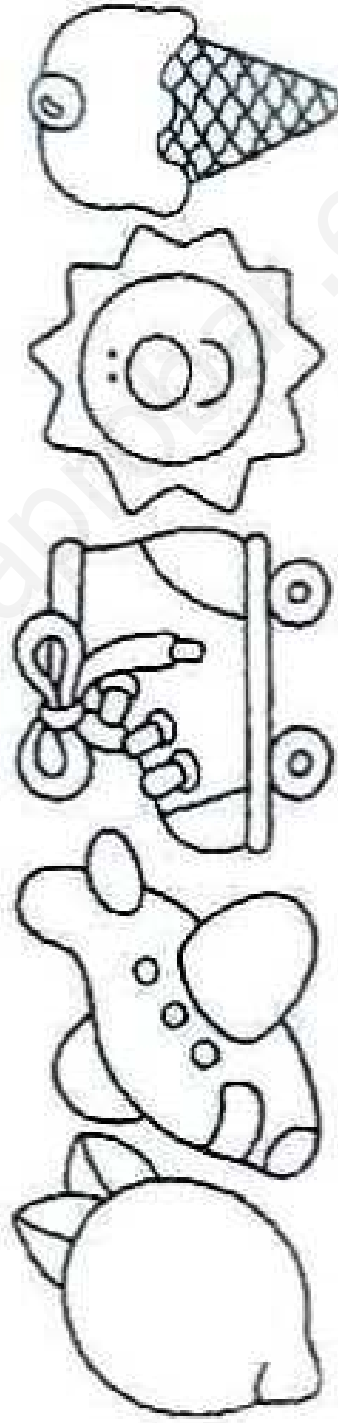

cerdo oso cinta sol helado

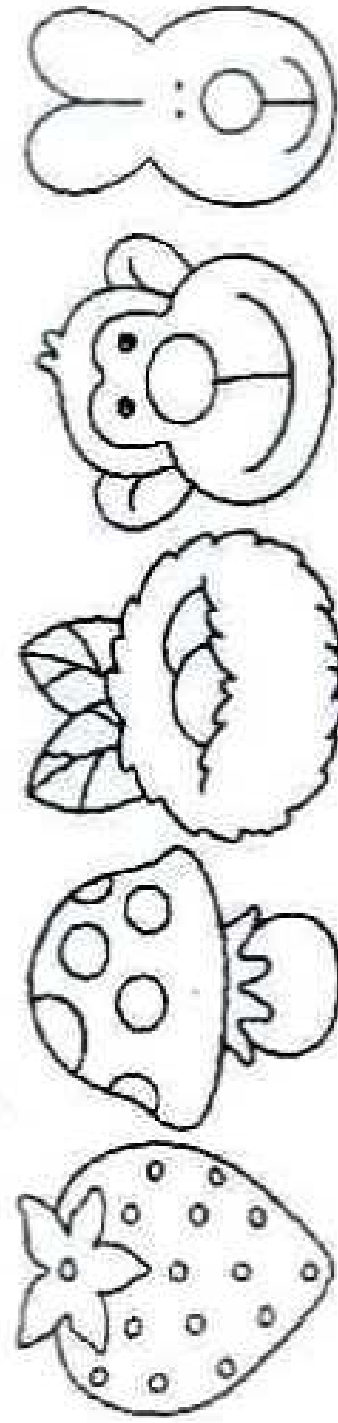

fresa hongo oso mono conejo

ESCRIBE EN CURSIVA LOS NOMBRES DE CADA MIEMBRO DE LA FAMILIA Y DE SUS MASCOTAS.

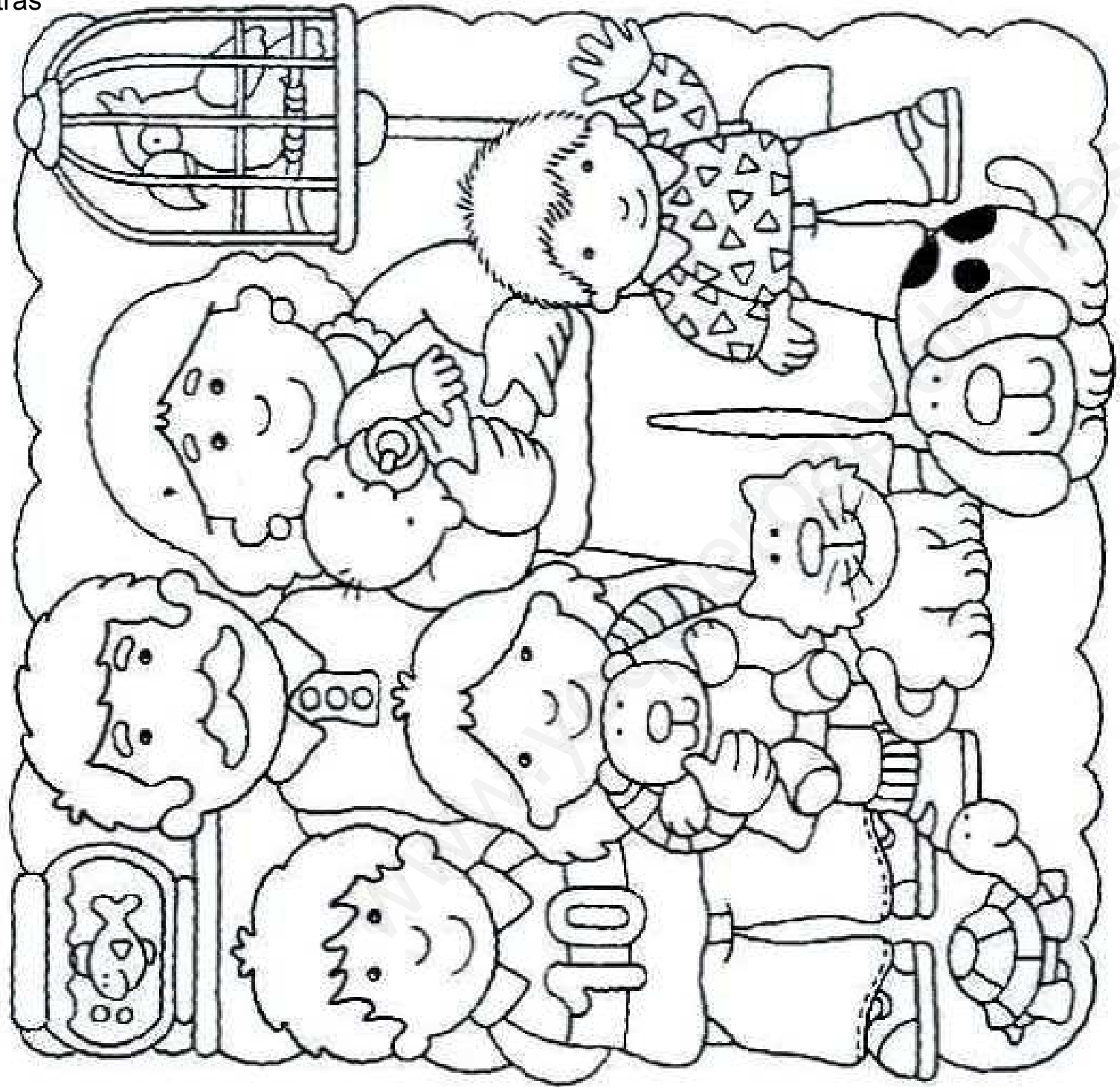

■ DIBUJA LOS ROSTROS DE ESTOS RETRATOS.
■ ESCRIBE DEBAJO UN NOMBRE PARA CADA UNO DE ELLOS.

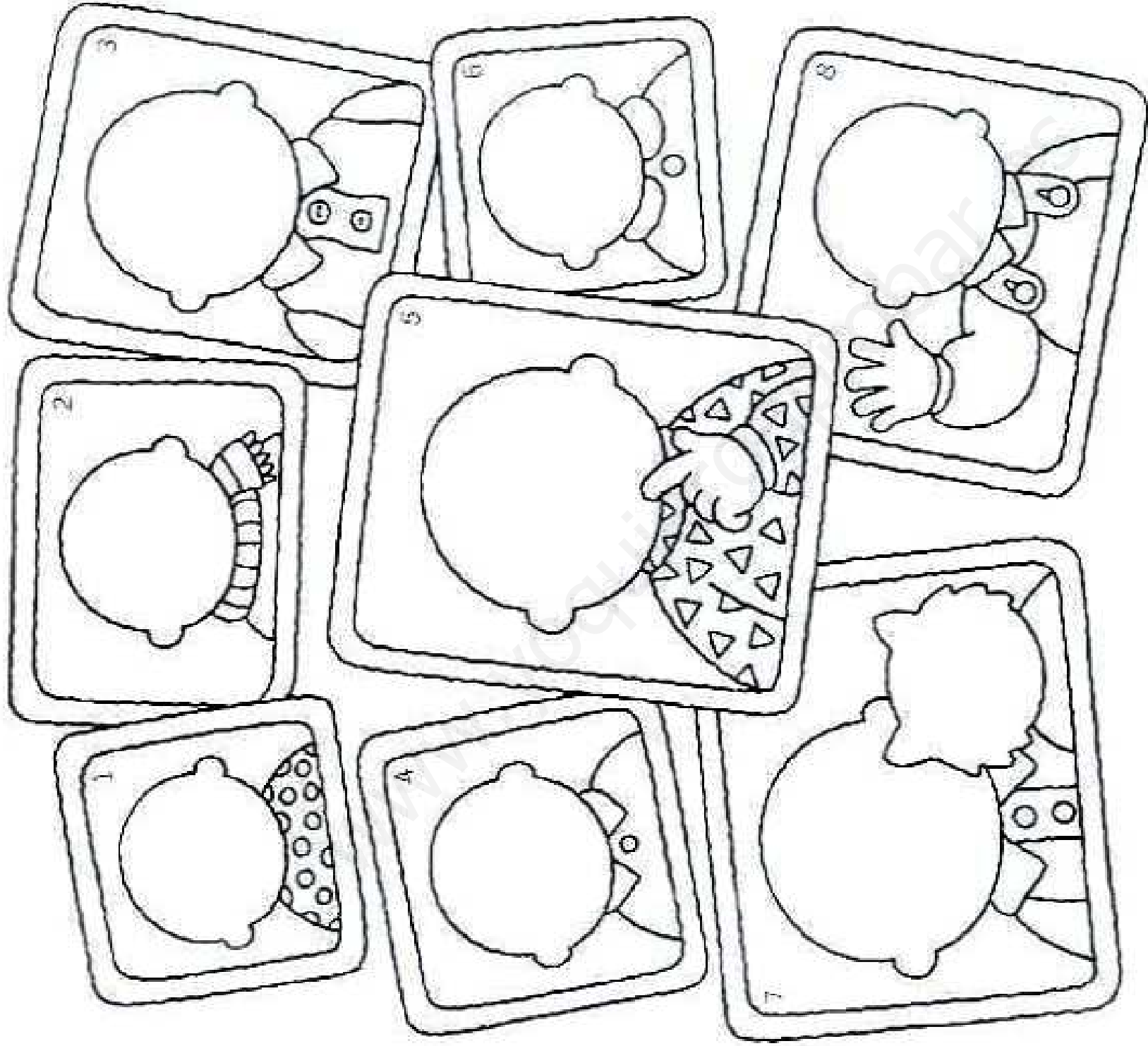

1
2
3
4

5
6
7
8

a A

b B

c C

d D

e E

f F

g G

h H

i I

j J

k K

l L

m M

n

www.yoquieroaprobar.es

ñ ñ

o o

p p

q q

r r

s s

t t

u u

v v

w w

x x

y y

z z

www.yoquieroaprobar.es

LÓGICA MATEMÁTICA



1 "LABERINTOS"

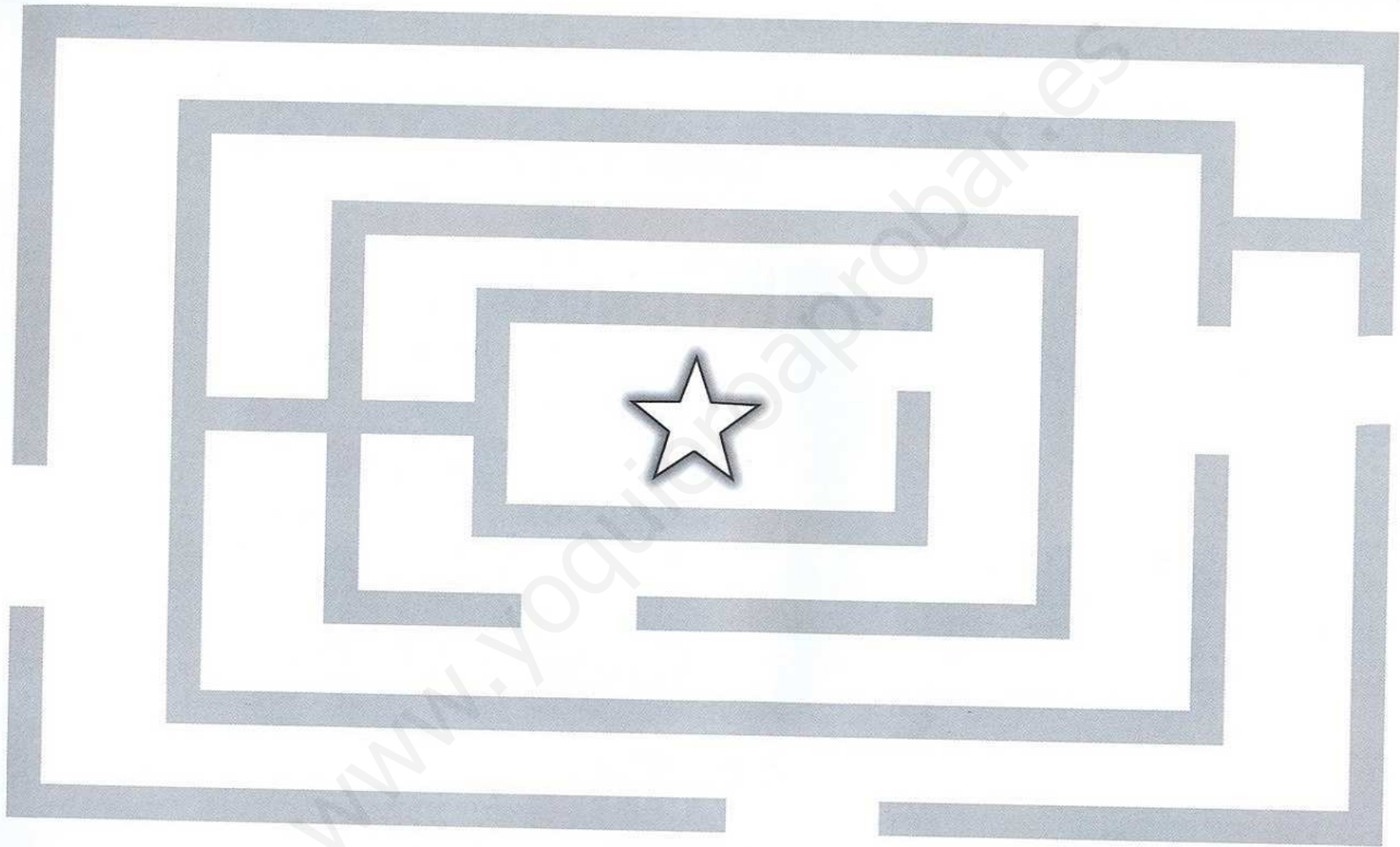

Actividad: Trazar un camino para encontrar la estrella.

Consejo: Sería conveniente recordar al niño o a la niña que cuando dibuje el laberinto no se "choque" con las "paredes" del dibujo.

RAZONAMIENTO ABSTRACTO

2

"ENCONTRAR DIFERENCIAS"

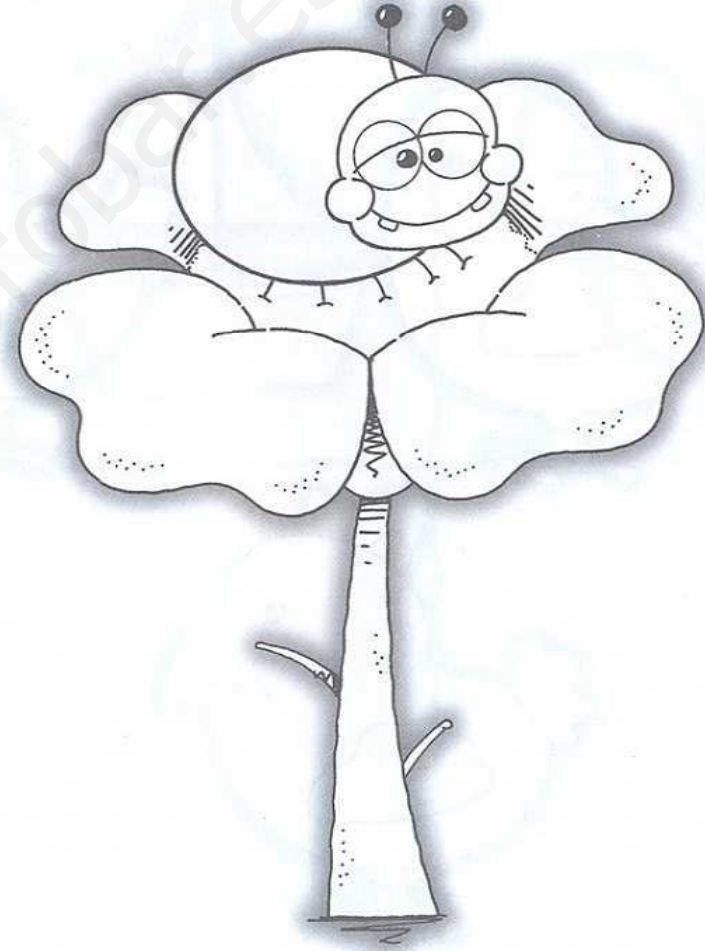

Actividad: Encontrar 3 diferencias en los dos dibujos.

Consejo: El niño o la niña ayudará a "descubrir las diferencias" que encuentren los papás en los pasatiempos de sus revistas. También pueden jugar a hacer dibujos "casi" iguales. ¿Descubrimos en qué se diferencian?

RAZONAMIENTO ABSTRACTO

3

“Descubrir errores en dibujos semejantes”

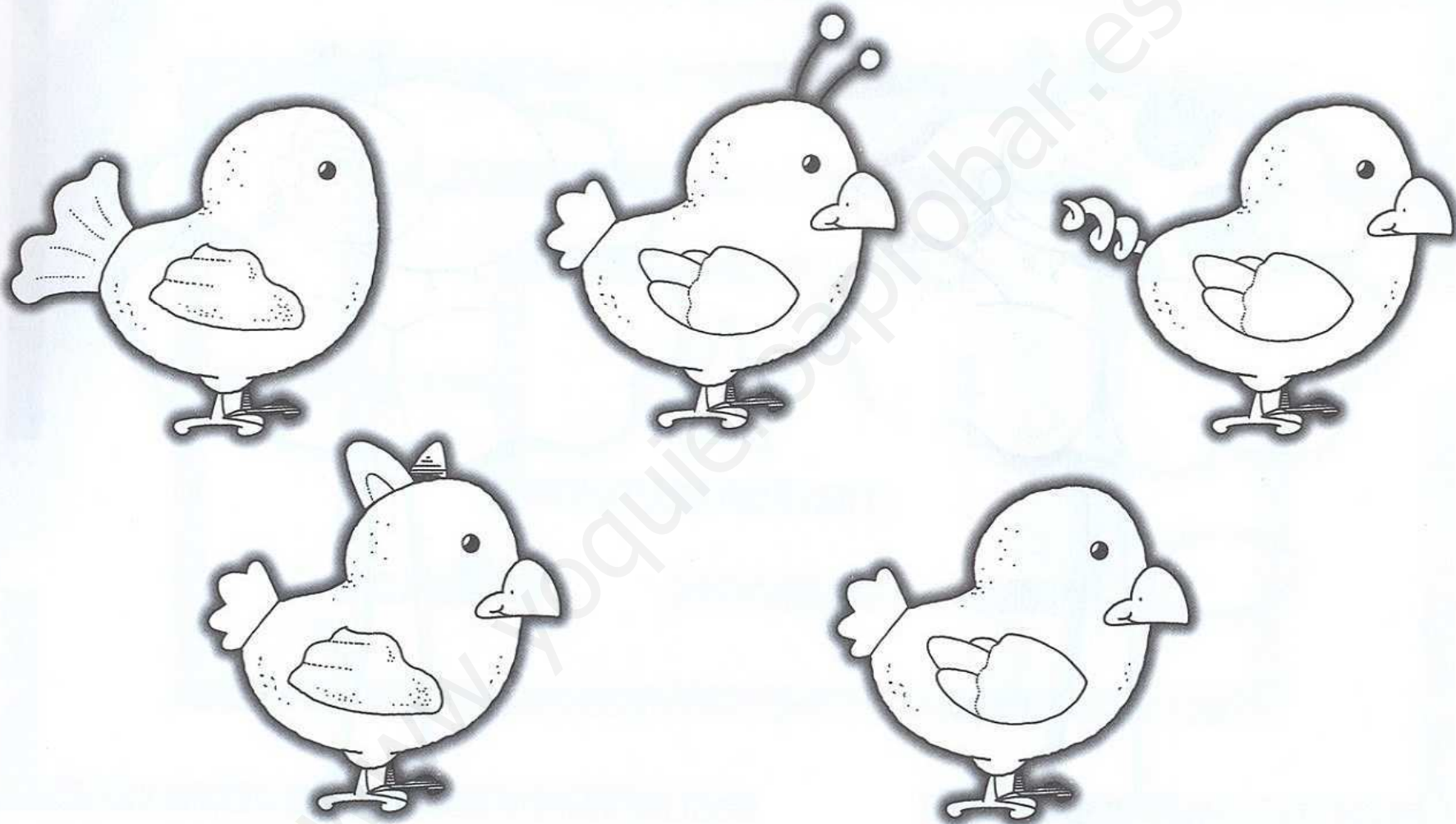

Actividad: Descubre los errores y colorea los pollitos.

Consejo: El niño o la niña introducirá en el cuarto de baño de su casa objetos que pertenecen a otras dependencias, después los papás o los hermanos intentarán adivinarlos y reubicarlos en su lugar correspondiente. Posteriormente se realizará el juego de forma contraria.

RAZONAMIENTO ABSTRACTO

4

"RESOLVER MATRICES"

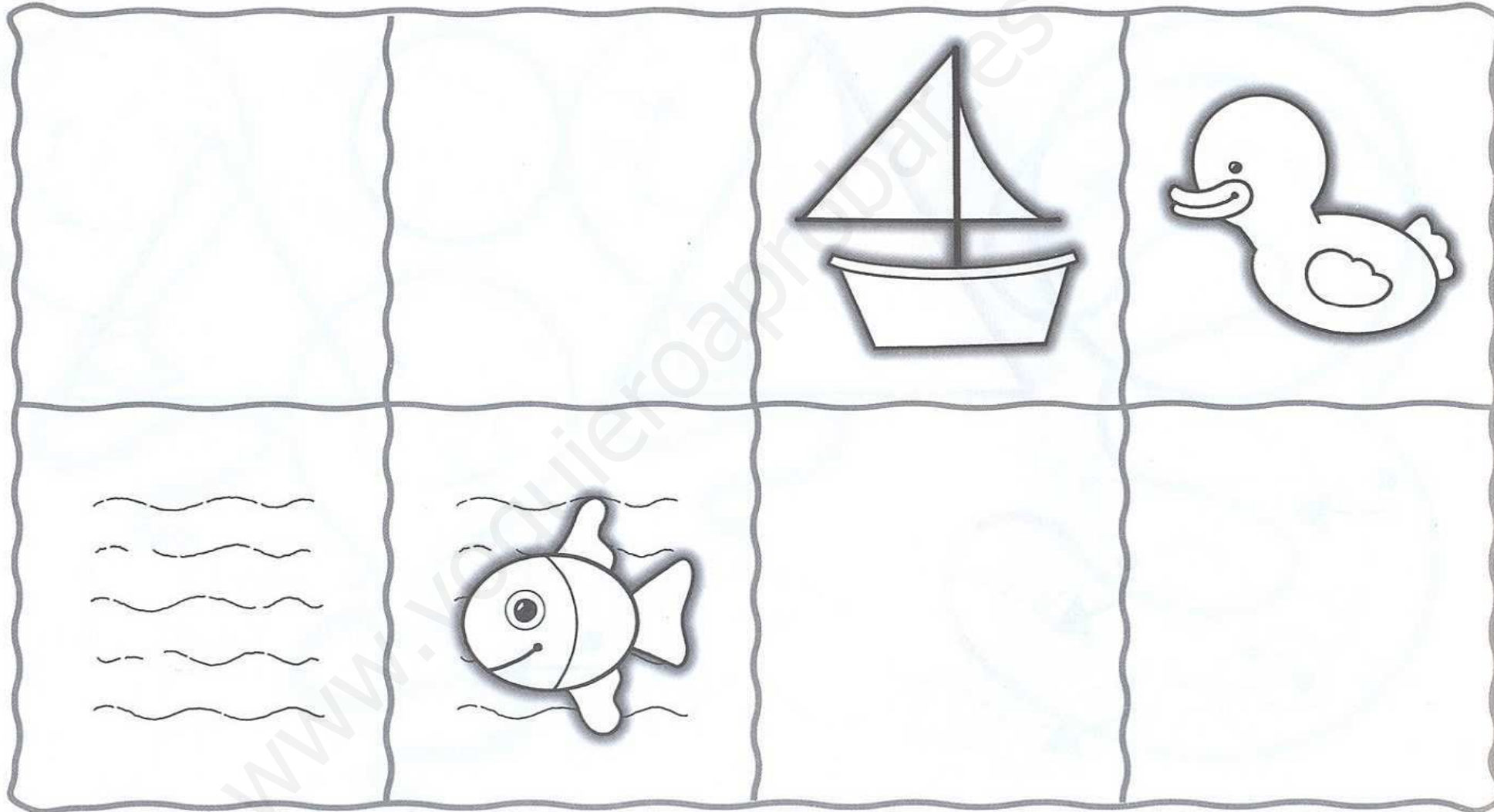

Actividad: Completa el cuadro.

Consejo: Niños o niñas charlarán sobre los elementos incorporados a la ficha una vez terminada.

¿Qué proceso hemos seguido para completarla de manera correcta?

GEOMETRÍA

5

Números. Libro 0 Lógica

LÍNEAS Y FORMAS GEOMÉTRICAS "líneas y formas geométricas"

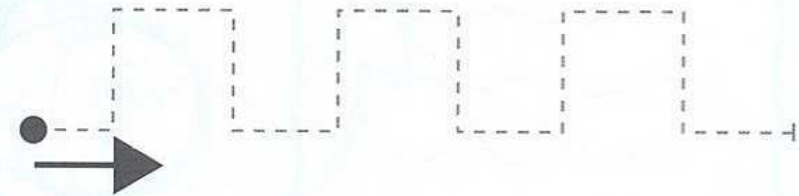
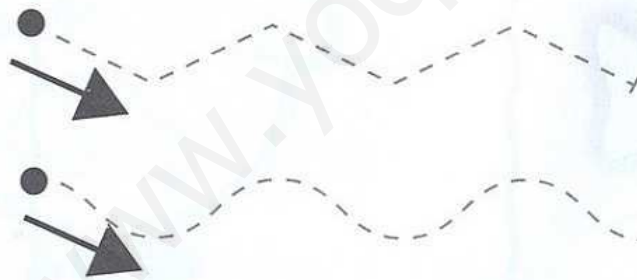
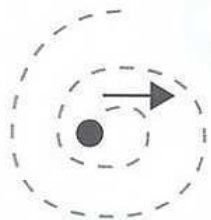
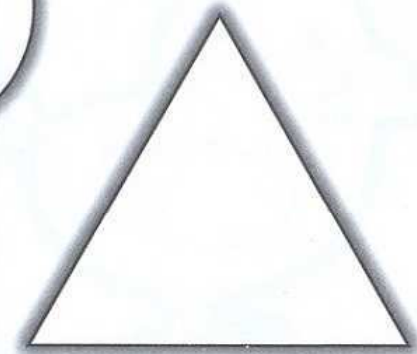
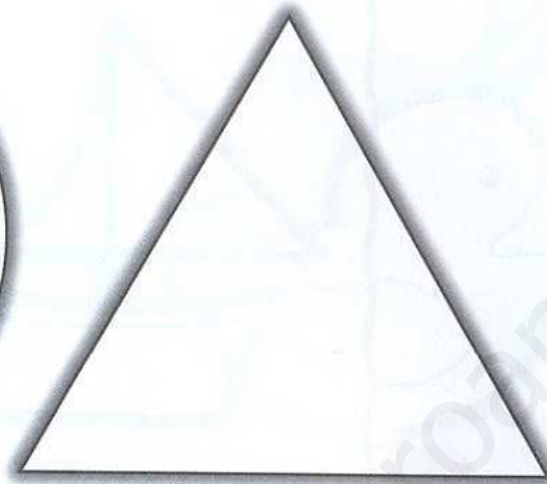

Actividad: Punzar las formas grandes, colorear las pequeñas. Reseguir.

Consejo: Utilizando los bloques lógicos, analizaremos las 4 formas básicas geométricas. El círculo: "redondo y sin piquitos". El cuadrado: "4 piquitos y 4 líneas rectas". El triángulo: "3 piquitos y 3 líneas rectas". El rectángulo: "4 piquitos y 4 líneas rectas, iguales 2 a 2".

NUMERACIÓN

6

NOCIÓN DE NÚMERO "conocer el número 3"

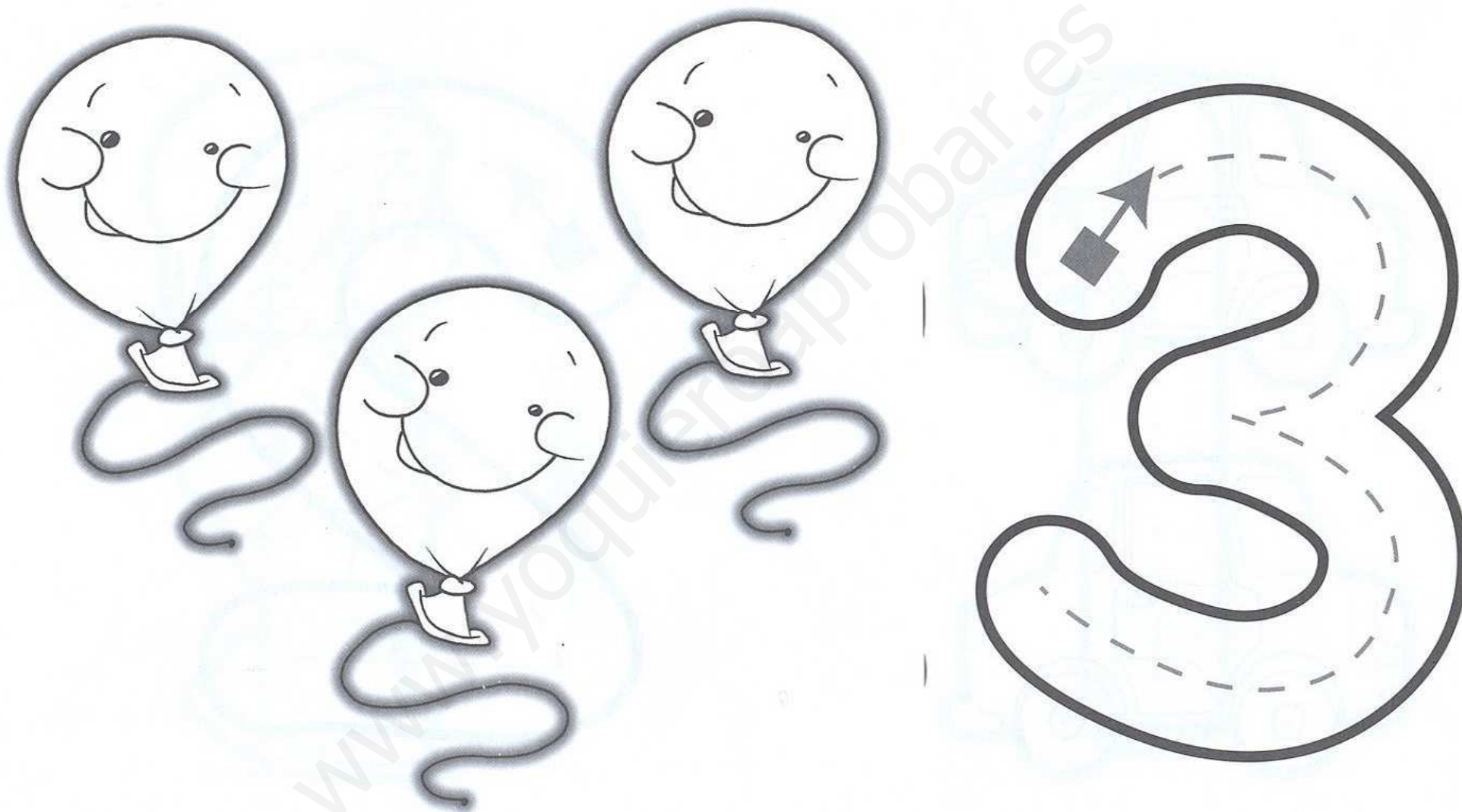

Actividad: Iniciación al número 3. Colorear y reseguir.

Consejo: El niño o la niña, utilizando las REGLETAS, hará agrupaciones de 3 regletas Nº1 (blancas) sobre la regleta Nº 3 (verde). Concepto trío - 3 unidades.

NUMERACIÓN

NOCIÓN DE NÚMERO ⁷ "conocer el número 2"

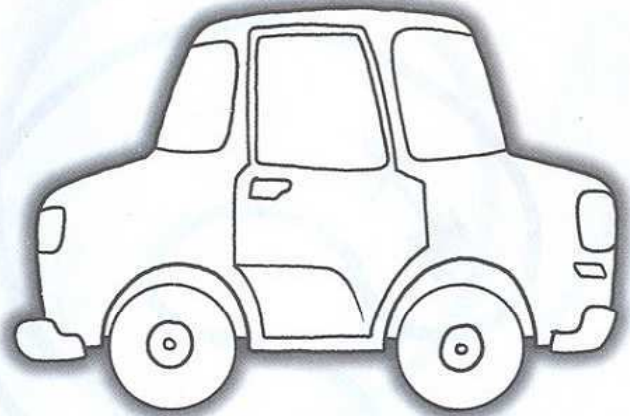

Actividad: Iniciación al número 2. Colorear y reseguir.

Consejo: El niño o la niña señalará las partes de su cuerpo que son PARES. (Concepto "par" 2)

NUMERACIÓN

8

NOCIÓN DE NÚMERO "conocer el número 1"

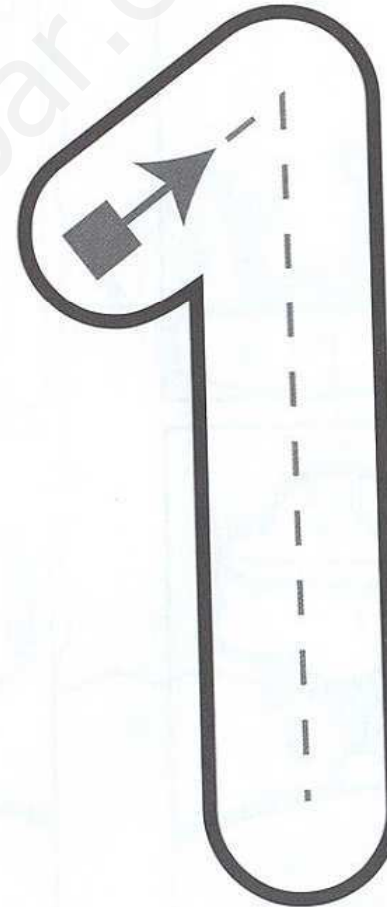

Actividad: Iniciación al número 1. Colorear y reseguir.

Consejo: El niño o la niña señalará las partes de su cuerpo que son ÚNICAS. (Concepto "unidad" 1)

SERIACIONES

SERIACIONES TEMPORALES "secuenciar acciones según un orden temporal"

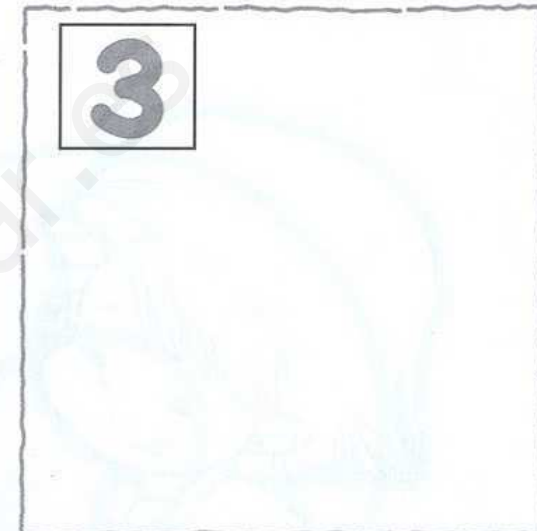
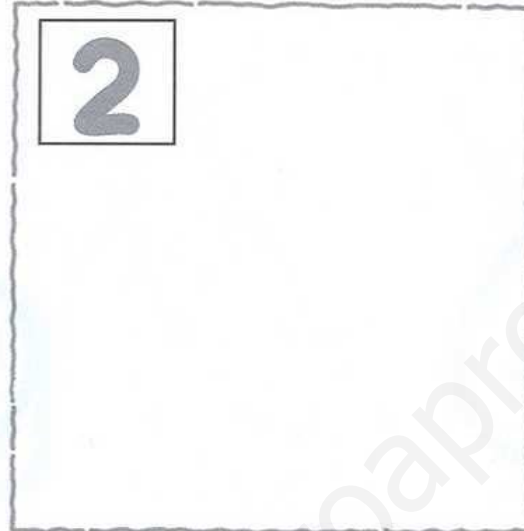
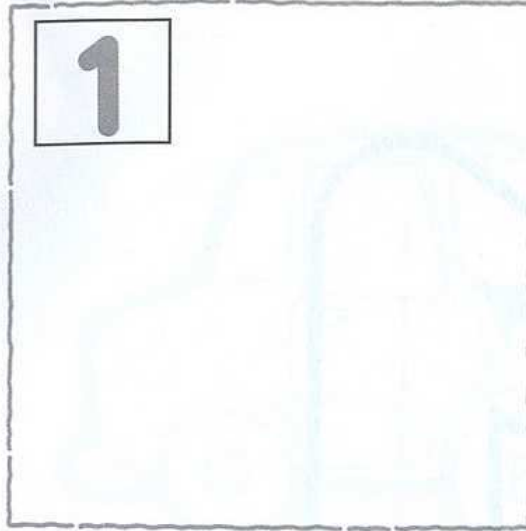

Actividad: Ordena la historia recortando las viñetas y pegándolas en la parte superior. Colorea.

Consejo: El niño o la niña dibujará la siguiente secuencia temporal de manera ordenada:

Me pongo los calcetines.

Me pongo un zapato y me lo abrocho.

Me pongo el otro zapato y me lo abrocho.

SERIACIONES

10

SERIACIONES TEMPORALES "secuenciar acciones"

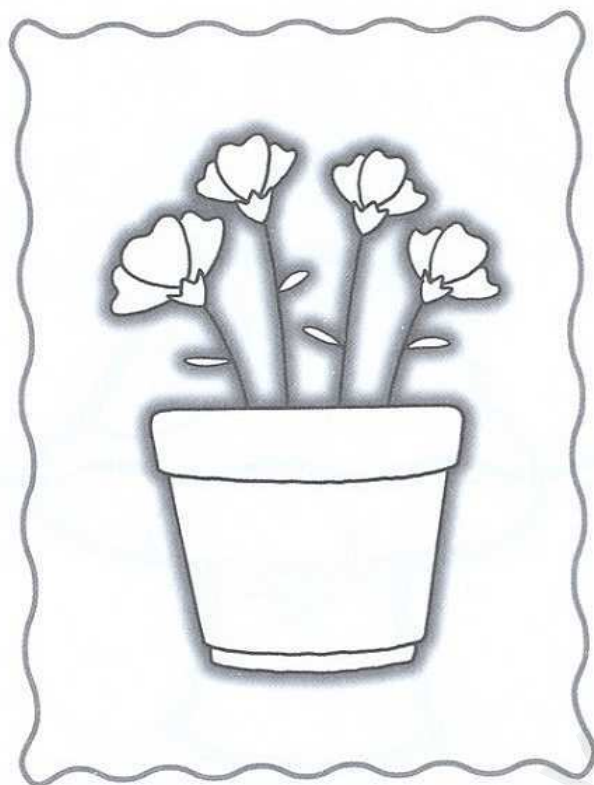



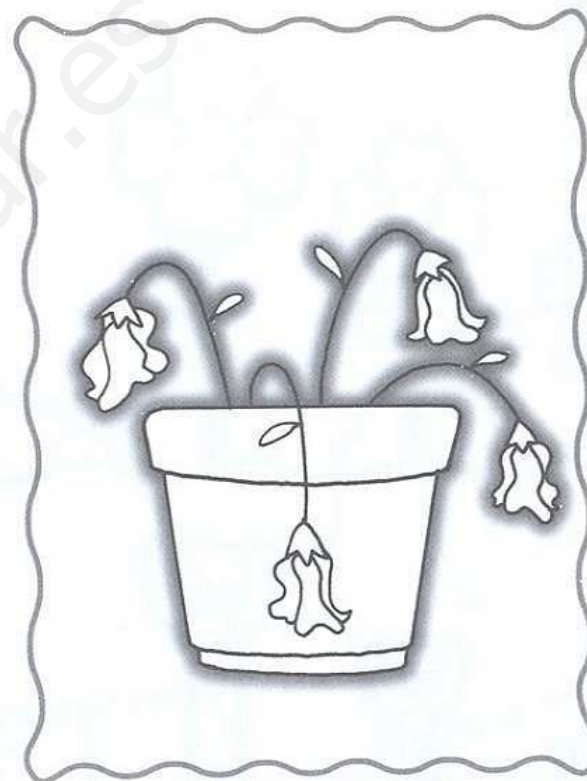

Actividad: Ordena la historia poniendo 1 - 2 - 3.

Consejo: El niño o la niña dibujará la siguiente secuencia temporal de manera ordenada:

Me lavo las manos para ir a comer.

Me pongo la servilleta para comer.

Me pongo a comer.

SERIACIONES

Números. Libro 0 Lógica

11

NOCIÓN DE SERIACIÓN "seriaciones de tres elementos"

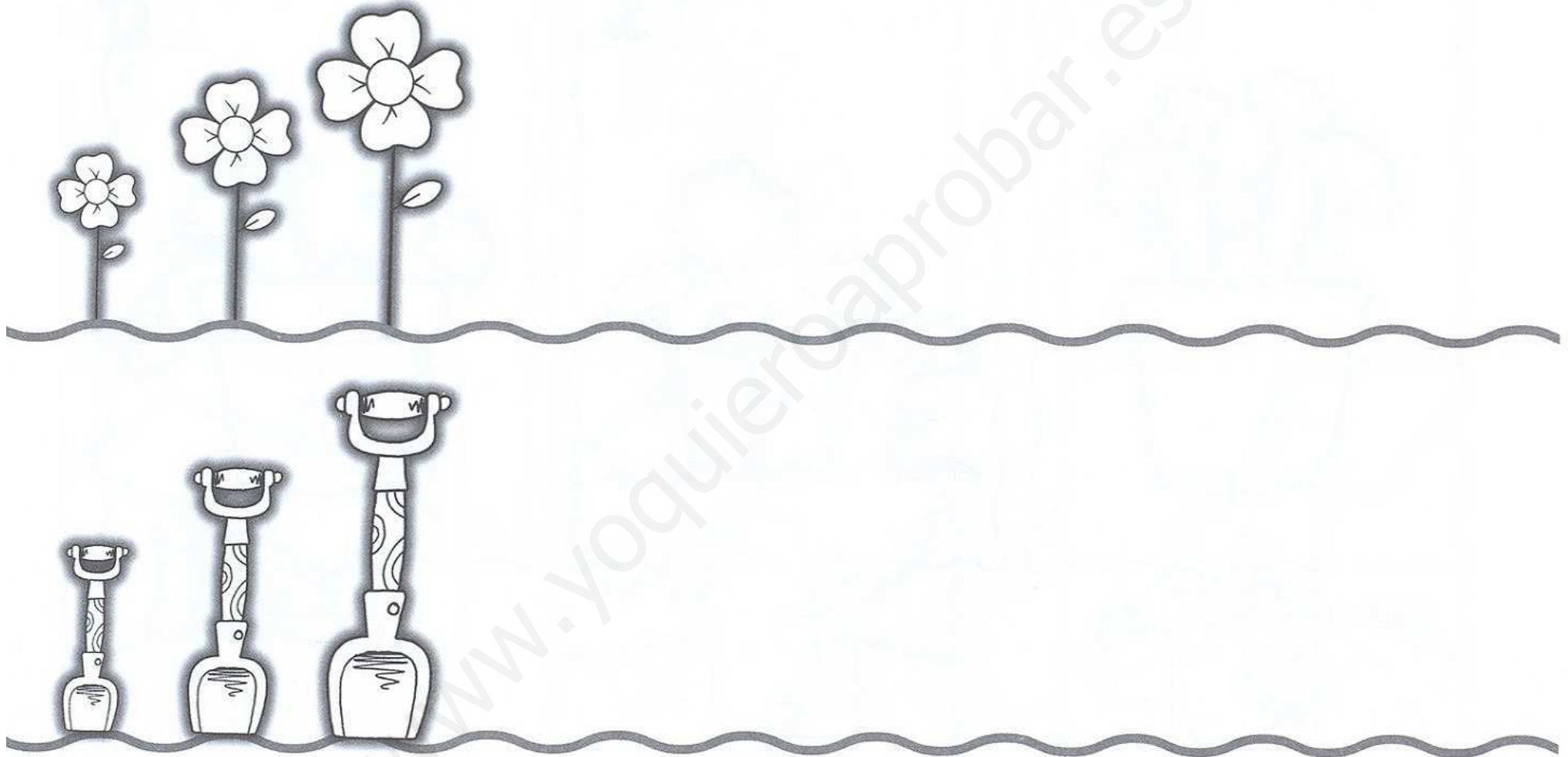

Actividad: Continúa las series.

Consejo: Utilizando los bloques lógicos, el niño o la niña realizará seriaciones con tres elementos alternados.

Por ejemplo: círculo rojo-cuadrado azul-triángulo amarillo-círculo rojo-cuadrado azul...

NOCIÓN DE SERIACIÓN “seriaciones alternando elementos”



Actividad: Colorea la serie alternando rojo - verde - rojo - verde.

Consejo: Utilizando los bloques lógicos, el niño o la niña realizará seriaciones con dos elementos alternados. Por ejemplo: círculo rojo - cuadrado azul - círculo rojo - cuadrado azul.

SERIACIONES

Números. Libro 0 Lógica

13

NOCIÓN DE SERIACIÓN "seriaciones de forma libre"

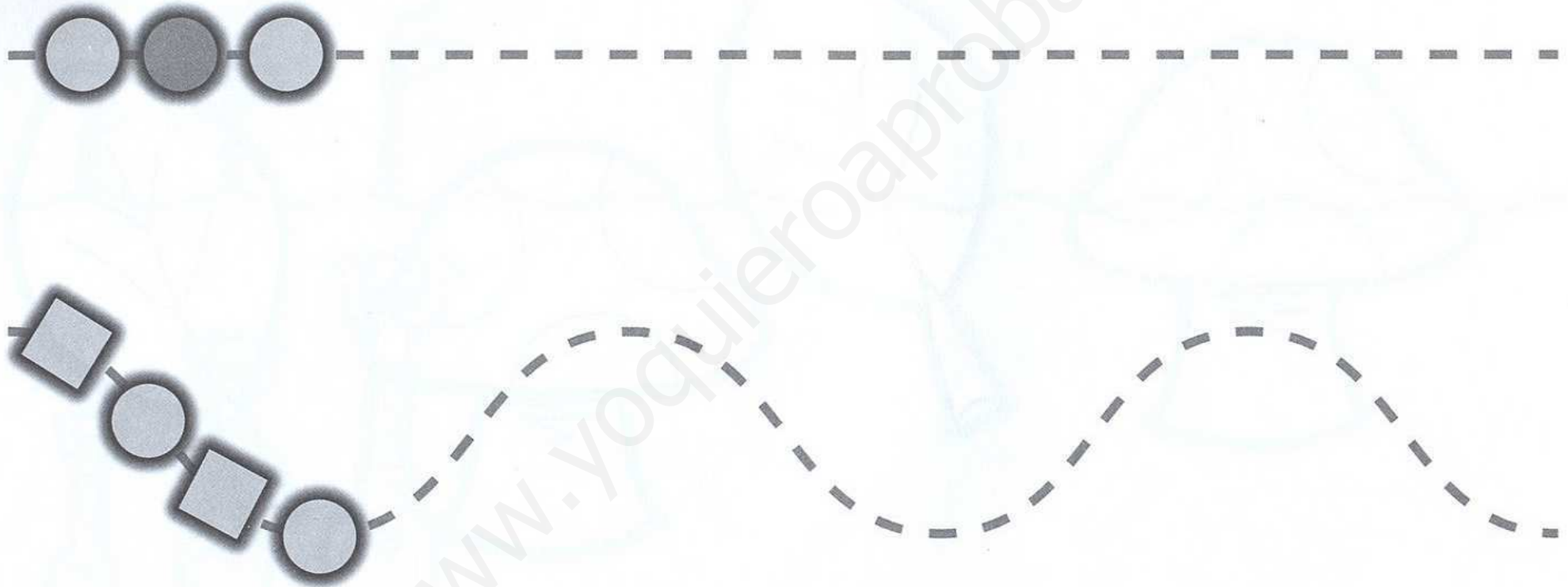

Actividad: Realiza una serie poniendo las formas en fila.

Consejo: Utilizando los bloques "lógicos", el niño o la niña realizará seriaciones libremente que contendrán los 4 atributos básicos. Posteriormente seriará según 1 atributo (círculos); más

adelante seriará teniendo en cuenta 2 atributos (círculos rojos) y así sucesivamente hasta llegar a utilizar los 4 atributos en el último curso de Educación Infantil.

CORRESPONDENCIA

14

NOCIÓN DE CORRESPONDENCIA "relación"



Actividad: Colorea del mismo color las flores iguales.

Consejo: El niño o la niña relacionará en clase series de objetos iguales. Por ejemplo: las cajas de ceras, los botes de pegamento, las fichas de trabajo antes de realizarse. Hablaremos de cada grupo de objetos y de sus semejanzas en forma, color, tamaño.

CORRESPONDENCIA

NOCIÓN DE CORRESPONDENCIA "asociaciones básicas"

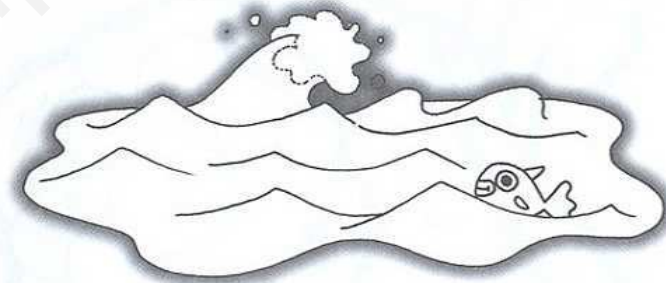
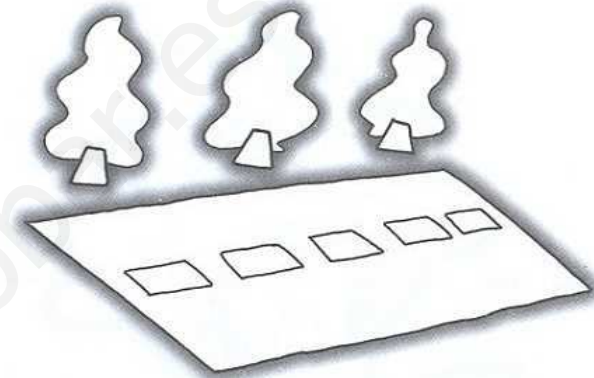
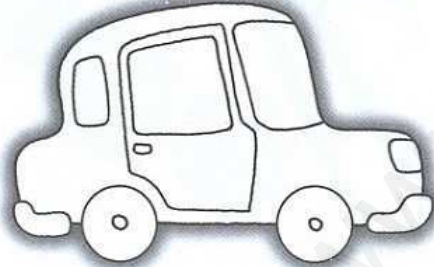
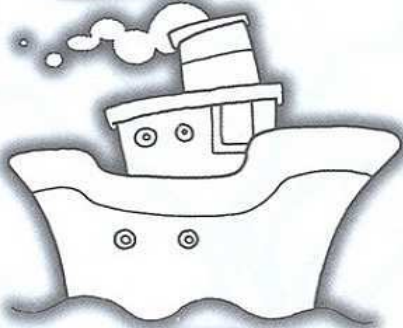
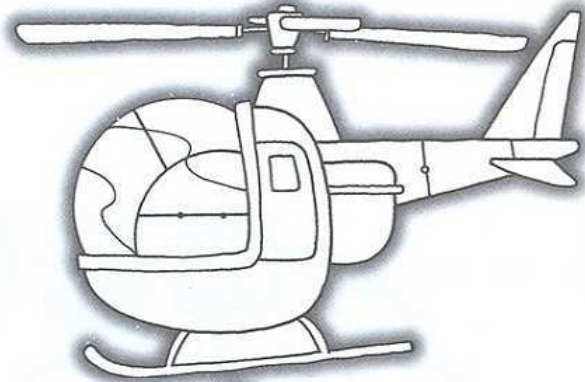

Actividad: Une cada medio de transporte con el lugar por donde se desplaza.

Consejo: El niño o la niña puede asociar una serie de animales, de una ilustración temática, con sus crías. Por ejemplo: la vaca y su ternero, la yegua y su potro. Se trata de ASOCIACIONES BÁSICAS, de primer grado.

CORRESPONDENCIA

NOCIÓN DE CORRESPONDENCIA "Establecer correspondencias"

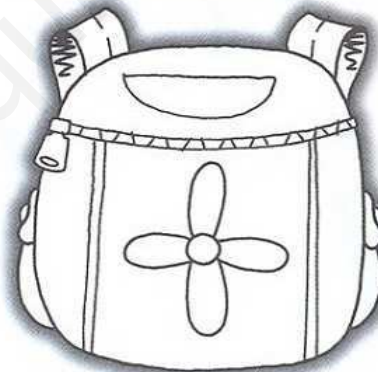

Actividad: "Une cada niño o niña con la mochila que tenga su mismo símbolo".

Consejo: El niño o la niña puede asociar los cepillos de dientes con los miembros de la familia: "El rojo grande es el de papá y SOLO DE PAPÁ, el verde pequeño es el mío y SOLO ES MÍO".

CLASIFICACIONES

Números. Libro 0 Lógica

17

NOCIÓN DE CLASIFICACIÓN "Clasificar objetos según dos criterios"



Actividad: Rodea los animales que tienen plumas.

Consejo: El niño o la niña puede clasificar algunos de los juguetes de su habitación teniendo en cuenta dos criterios, "nuevos con elementos circulares" o "viejos y de colores variados".

CLASIFICACIONES

NOCIÓN DE CLASIFICACIÓN "Clasificar objetos según un criterio"

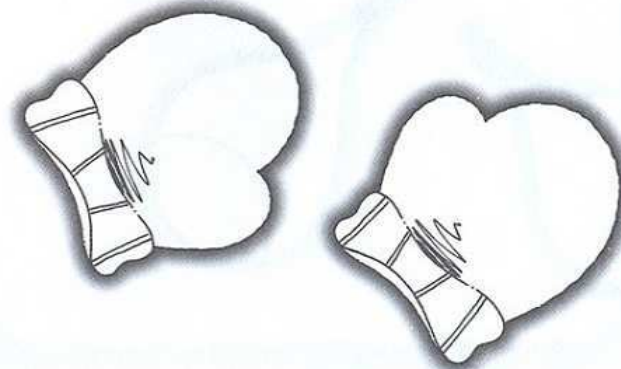
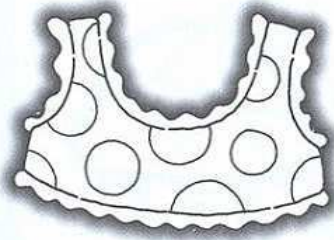
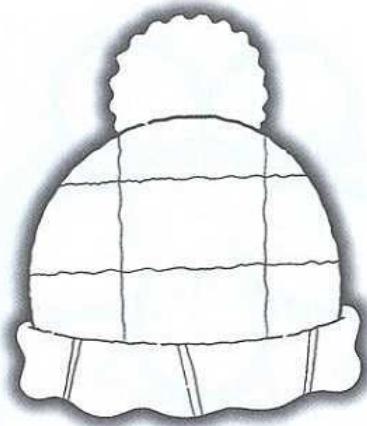

Actividad: Rodea la ropa de invierno. Colorea.

Consejo: El niño o la niña puede clasificar algunos de los juguetes de su habitación según el criterio nuevo - viejo.

NOCIÓN DE CONJUNTOS "agrupaciones"

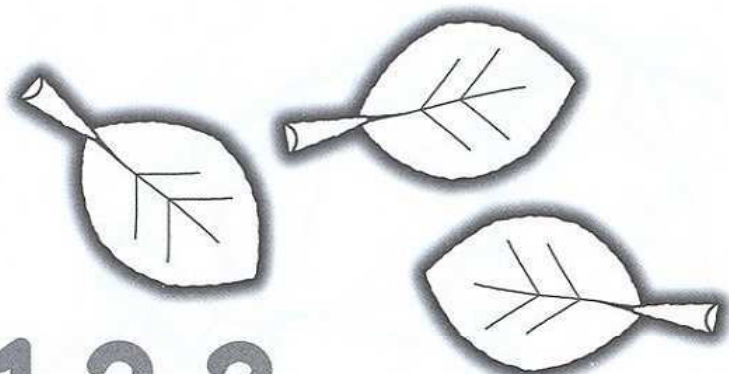

1 2 3

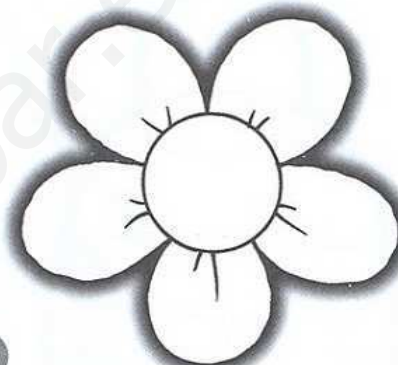

1 2 3

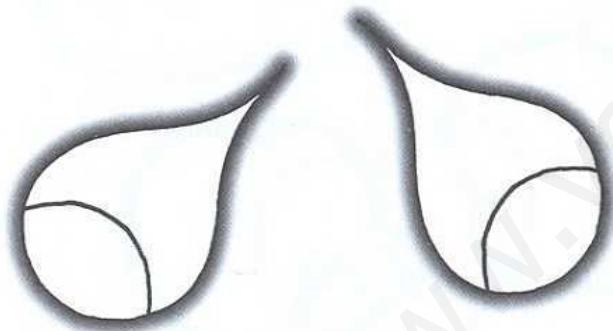

1 2 3



1 2 3

Actividad: Rodea el número de elementos de cada conjunto: 1, 2 ó 3.

Consejo: El niño o la niña guardará en una cajita caramelos según el número que la profesora le diga.

CONJUNTOS

20

NOCIÓN DE CONJUNTOS "noción de cardinal"

2

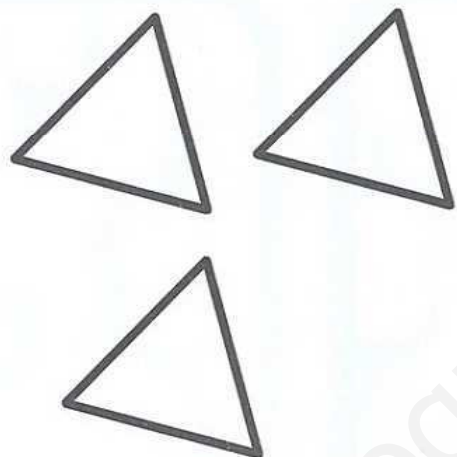

Actividad: Completa la etiqueta y el diagrama para cumplir el criterio.

Consejo: El niño o la niña jugará a "pintar elementos según el cardinal correspondiente". Se presentarán conjuntos vacíos con los cardinales 1, 2, 3.
Se rellenarán contando despacito los elementos.

CONJUNTOS

Números. Libro 0 Lógica

21

NOCIÓN DE CONJUNTOS "noción de cardinal"

The image shows three sets for a drawing activity. Each set consists of a key (a shape in a box with an arrow) and a cardinal number in a box. Below each key is a large empty rounded rectangle for drawing.

- Set 1: Key is a circle in a box with an arrow pointing to a box containing the number 2.
- Set 2: Key is a square in a box with an arrow pointing to a box containing the number 1.
- Set 3: Key is a triangle in a box with an arrow pointing to a box containing the number 3.

Actividad: Dibuja dentro de cada conjunto lo que indica la clave.

Consejo: El niño o la niña jugará a "pintar conjuntos" con objetos de 1, 2 y 3 elementos. Pueden ser objetos variados pero también la profesora puede iniciar el concepto "igual" o "semejante". Por ejemplo: Pintamos un conjunto de 2 flores exactamente iguales, después escribimos su cardinal.

NOCIÓN DE CONJUNTOS "agrupación de forma libre"



Actividad: Agrupa los elementos de forma libre. Colorea.

Consejo: El niño o la niña puede agrupar "pelotas de goma" en la sala de psicomotricidad libremente, así conocerá el concepto de agrupación. "Varios elementos juntos" o bien "un elemento separado".

TAMAÑO "grande-pequeño"

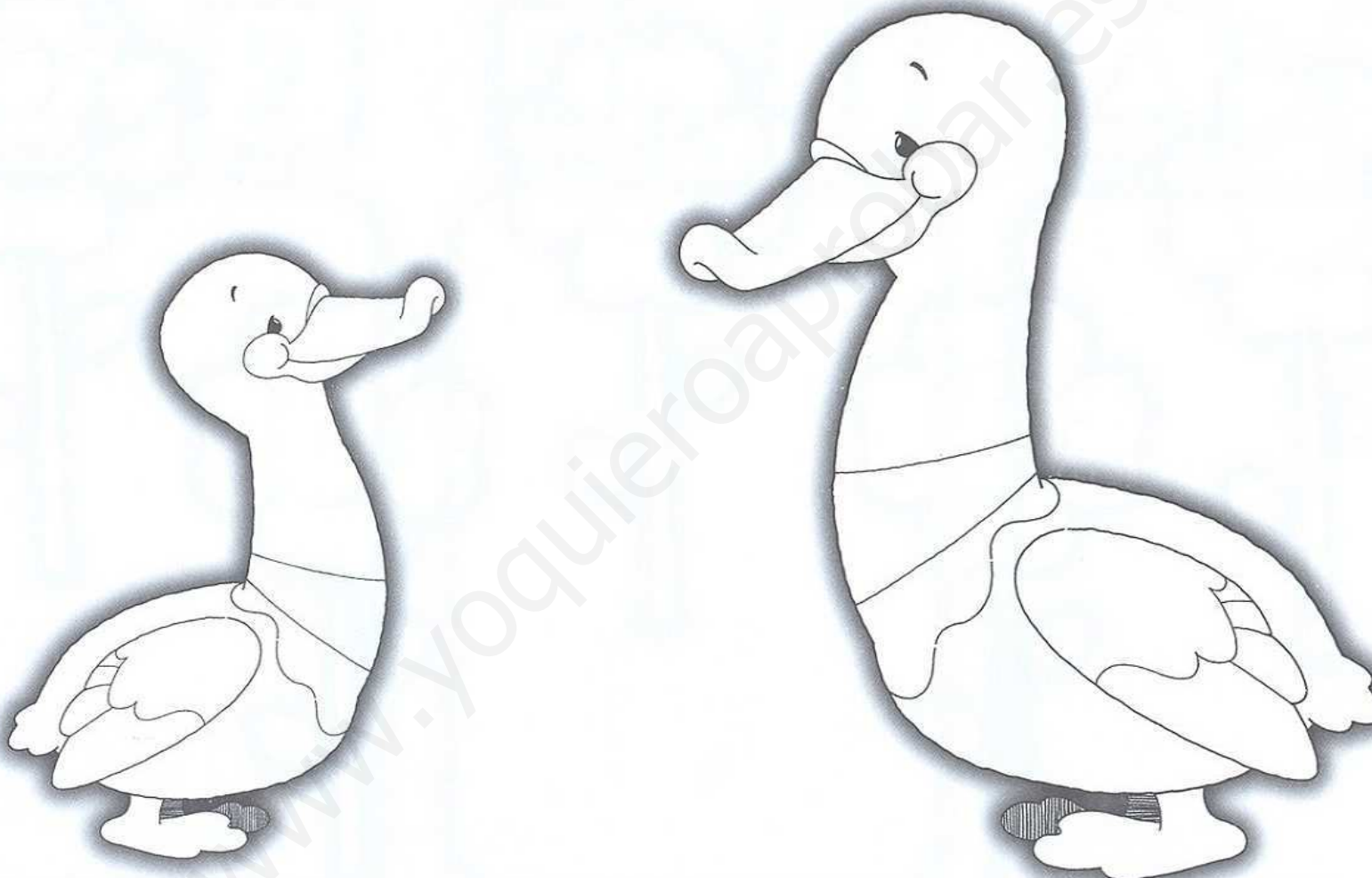

Actividad: Colorea el animal grande. Señala el animal pequeño.

Consejo: El niño o la niña señalará las partes de nuestro cuerpo que son pequeñas y las que son grandes. Una vez verbalizadas podemos contarlas.

CUANTIFICADORES BÁSICOS

TAMAÑO "grande-mediano-pequeño"²⁴



Actividad: Pega papelitos en las flores grandes y colorea de rosa las flores medianas.

Consejo: El niño o la niña recordará el cuento "Ricitos de oro y los 3 osos". ¿Cómo era el plato de sopa de mamá osa? ¿Y el de papá oso? ¿Y el de osito?

Números. Libro 0 Lógica

TAMAÑO ²⁵ "grande-pequeño"



Actividad: Colorea el gato grande.

Consejo: El niño o la niña verbalizará 5 animales de tamaño grande y los irá contando con los 5 dedos de su mano; seguirá el mismo proceso con 5 animales de tamaño pequeño.

CUANTIFICADORES BÁSICOS

26

ESPACIALES "encima-debajo"

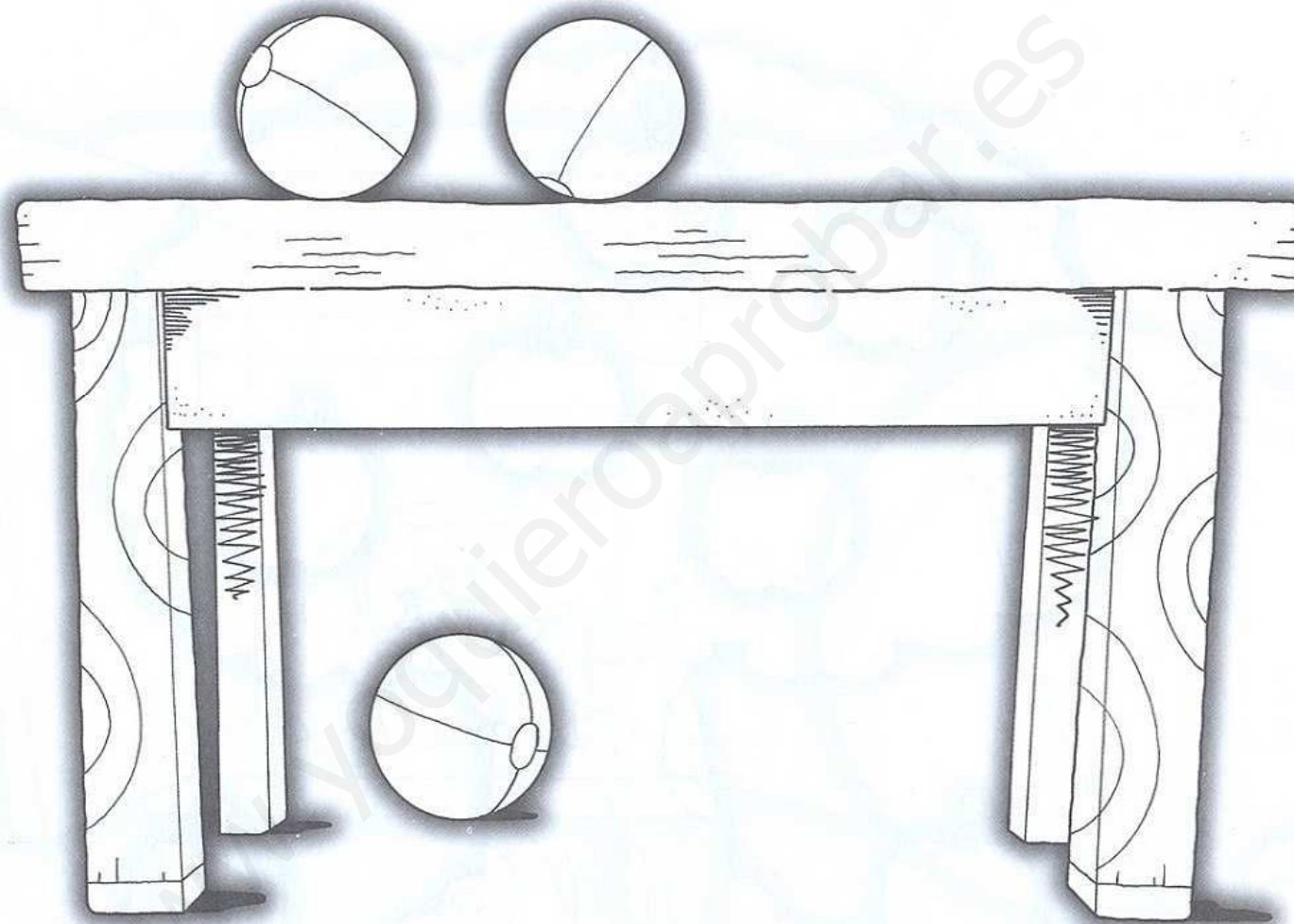

Actividad: Pica las pelotas que están encima de la mesa. Colorea la pelota que está debajo de la mesa.

Consejo: El niño o la niña jugará al "escondite de las manos", según una orden de la profesora: "Una palmada, **TODOS PONEMOS LAS MANOS DEBAJO DE LA MESA DE TRABAJO**; dos palmadas, **PONEMOS LAS MANOS ENCIMA DE LA MESA DE TRABAJO**".

CUANTIFICADORES BÁSICOS

27

ESPACIALES "arriba-abajo"



Actividad: Colorea de rojo las manzanas que están arriba y de amarillo las que están abajo.

Consejo: El niño o la niña verbalizará objetos que están arriba (en el techo) y objetos que están abajo (en el suelo). En la calle también puede verbalizar qué objetos o animales están arriba (en el cielo) y qué objetos o animales están abajo (en la acera); este mismo ejercicio se puede realizar en el campo.

CUANTIFICADORES BÁSICOS

28

ESPACIALES "dentro-fuera"

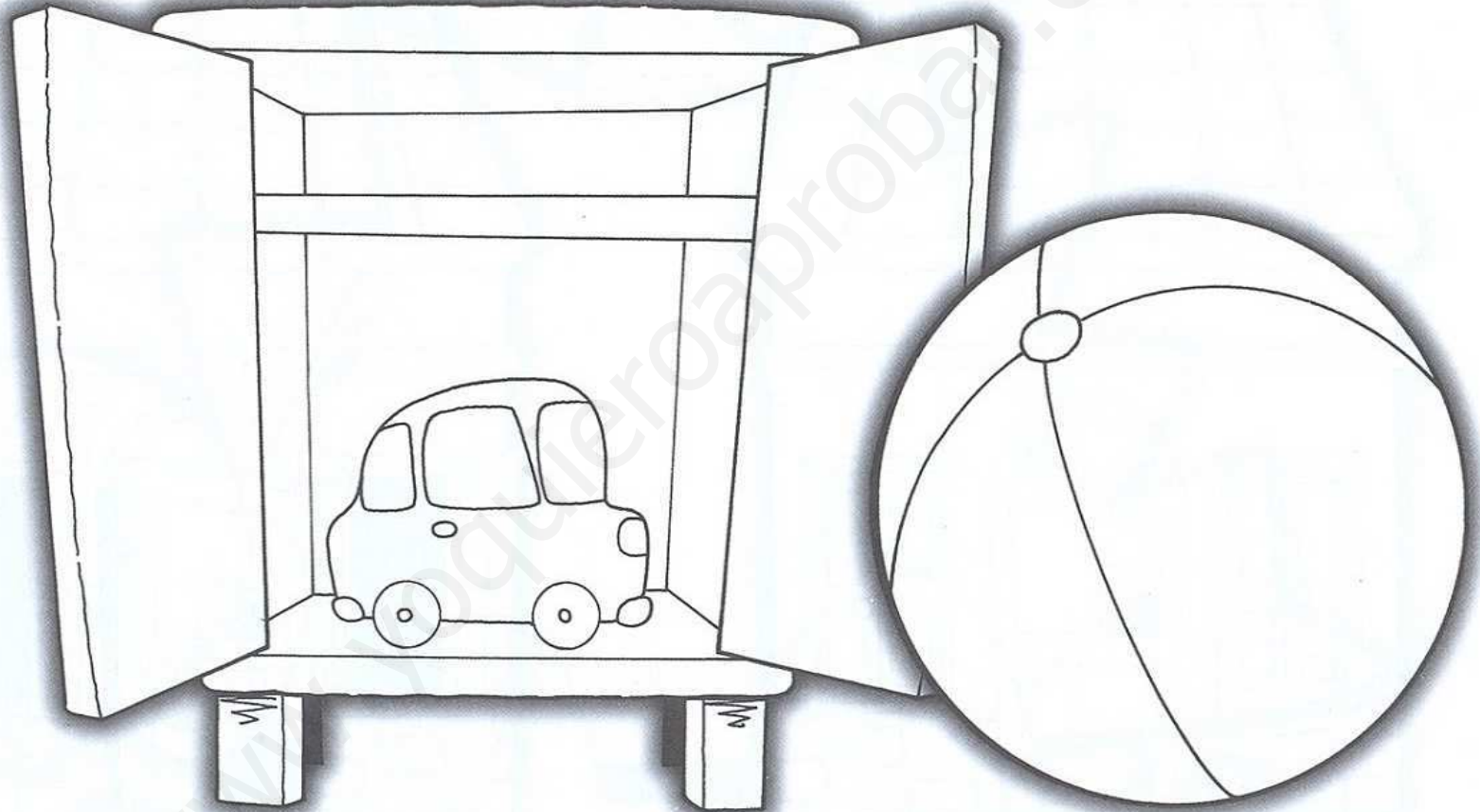

Actividad: Colorea el juguete que está dentro del armario. Pega un gomet en el juguete que está fuera del armario.

Consejo: El niño o la niña puede aprender esta noción espacial utilizando aros de psicomotricidad. Es muy recomendable un juego de atención-concentración: "Una palmada de la profesora, TODOS FUERA DEL ARO; dos palmadas de la profesora, TODOS DENTRO DEL ARO".

ESPACIALES "abierto-cerrado"

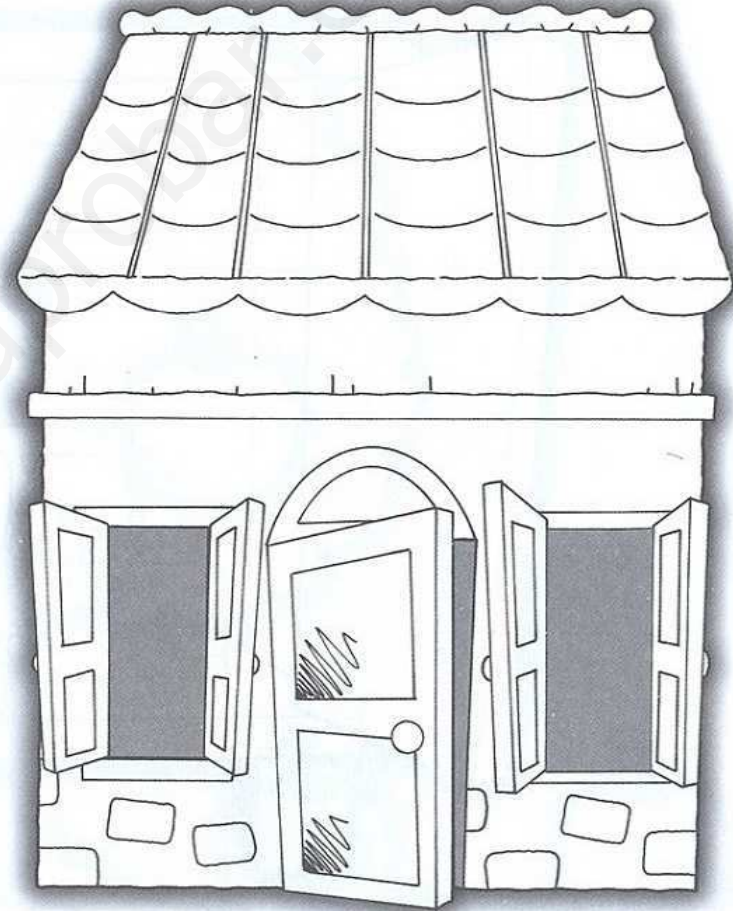
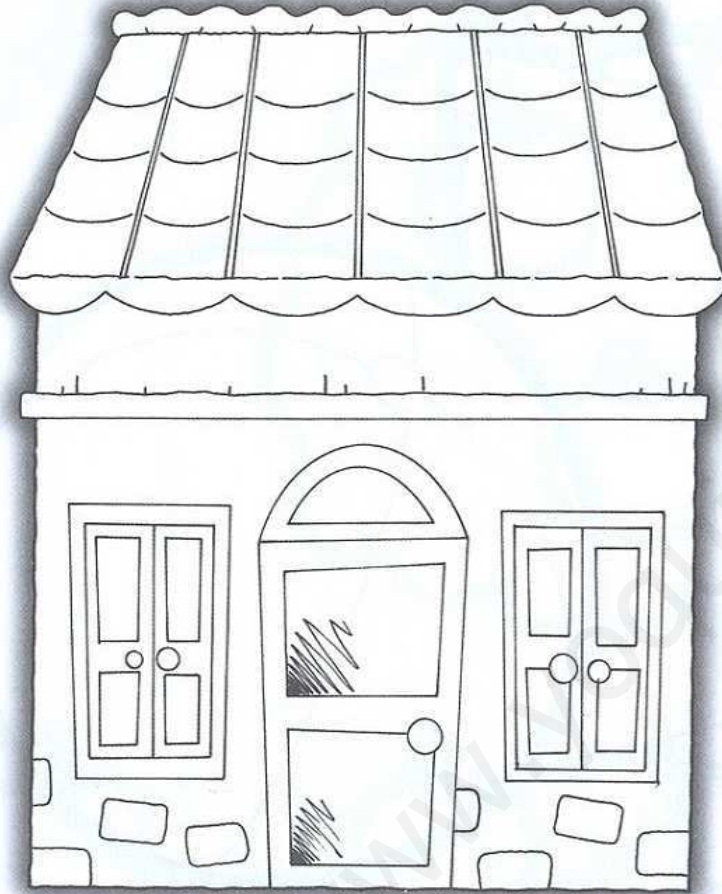

Actividad: Señala la casa que tiene las ventanas y la puerta cerradas.

Consejo: El niño o la niña puede aprender esta noción espacial utilizando la plastilina. Creará líneas y formas cerradas y abiertas modelándolas.

CUANTIFICADORES BÁSICOS

30

TEMPORALES "primero-último"

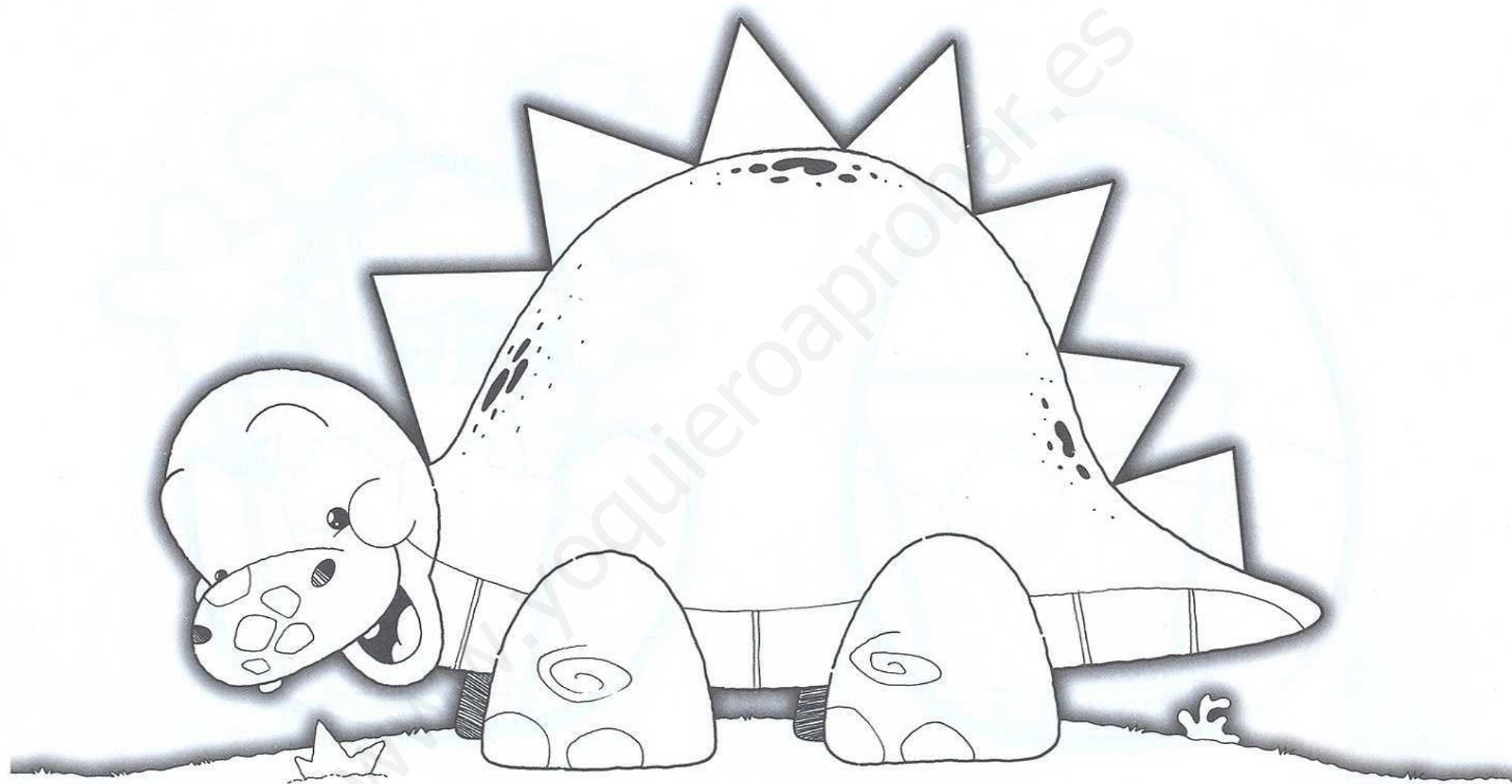

Actividad: Colorea el cuerpo del dinosaurio. Pega un gomet en el primer triángulo y otro en el último.

Consejo: El niño o la niña puede aprender esta noción temporal y ordinal en el orden de la fila de clase, la profesora insistirá en qué niño o niña ocupa el lugar primero y que niña o niño ocupa el último lugar.

CUANTIFICADORES BÁSICOS

31

TEMPORALES "antes - después"

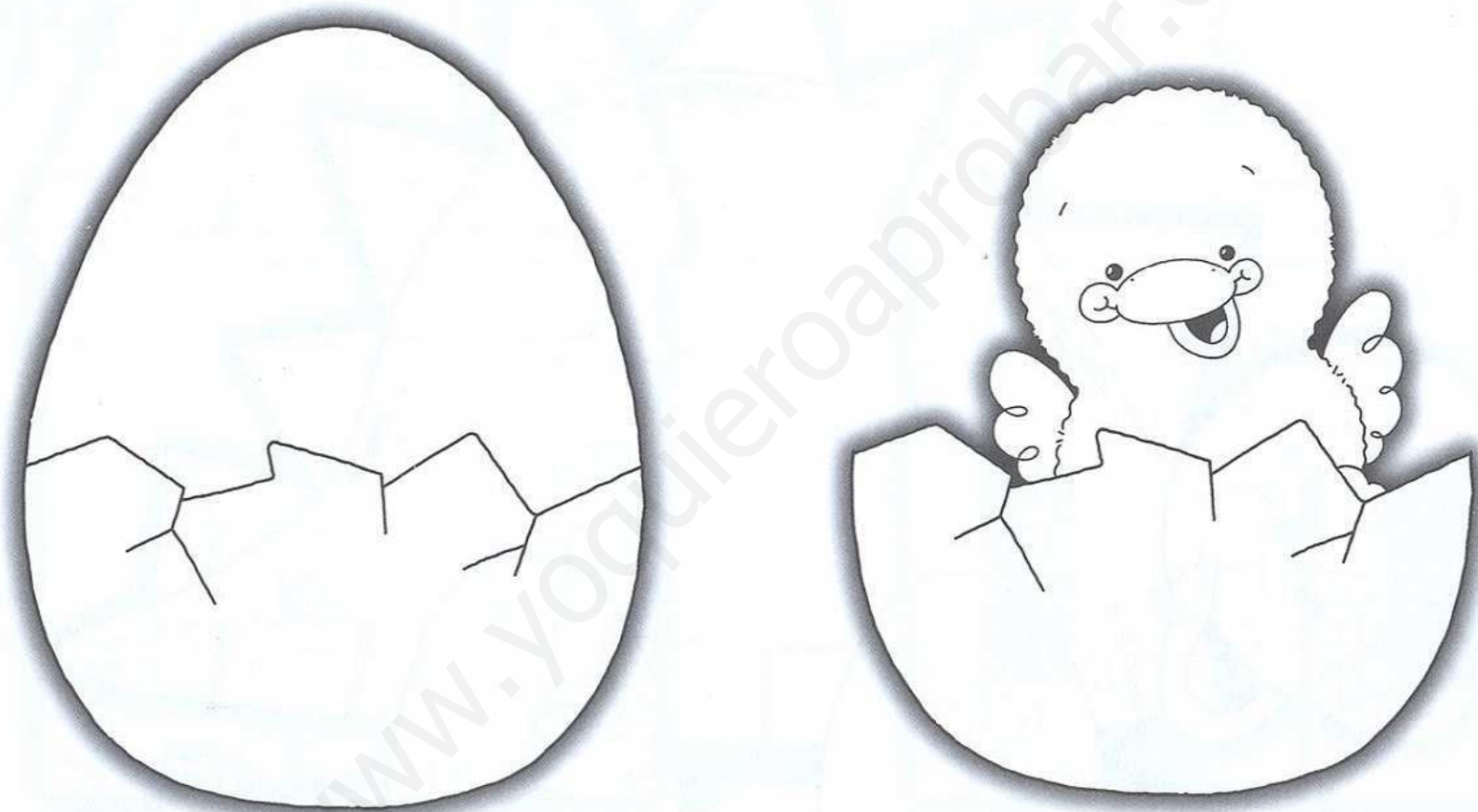

Actividad: Colorea el dibujo que representa al pollito después de nacer.

Consejo: El niño o la niña observará y comentará qué pasa en esta secuencia temporal antes y después. La cáscara del huevo comienza a romperse (antes), nace el pollito (después). Se puede aprovechar este concepto en momentos cotidianos. Por ejemplo: cuando llegue la hora de acostarse por la noche ... "antes me pongo el pijama", "después me acuesto y mi mamá o mi papá me lee un cuento".

CUANTIFICADORES BÁSICOS

32

CANTIDAD "más que - menos que"

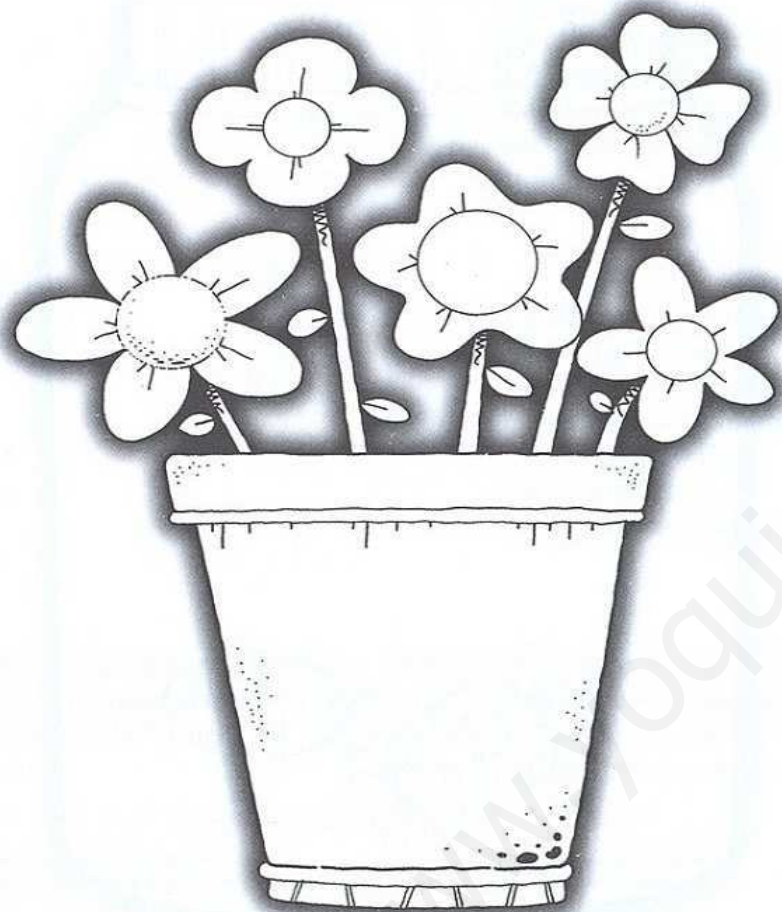

Actividad: Colorea los floreros y señala el que tiene más flores.

Consejo: El niño o la niña utilizará esta noción de cantidad en sus actividades cotidianas.

Por ejemplo: "En el coche, vamos a jugar a identificar más coches rojos que azules mirando por la ventanilla", "vamos a identificar edificios o casas de nuestra ciudad que tengan más ventanas que otros ...". Se trata de que asimile el concepto "más que-menos que" contando visualmente.

CUANTIFICADORES BÁSICOS

Números. Libro 0 Lógica

CANTIDAD ³³ "muchos - pocos"

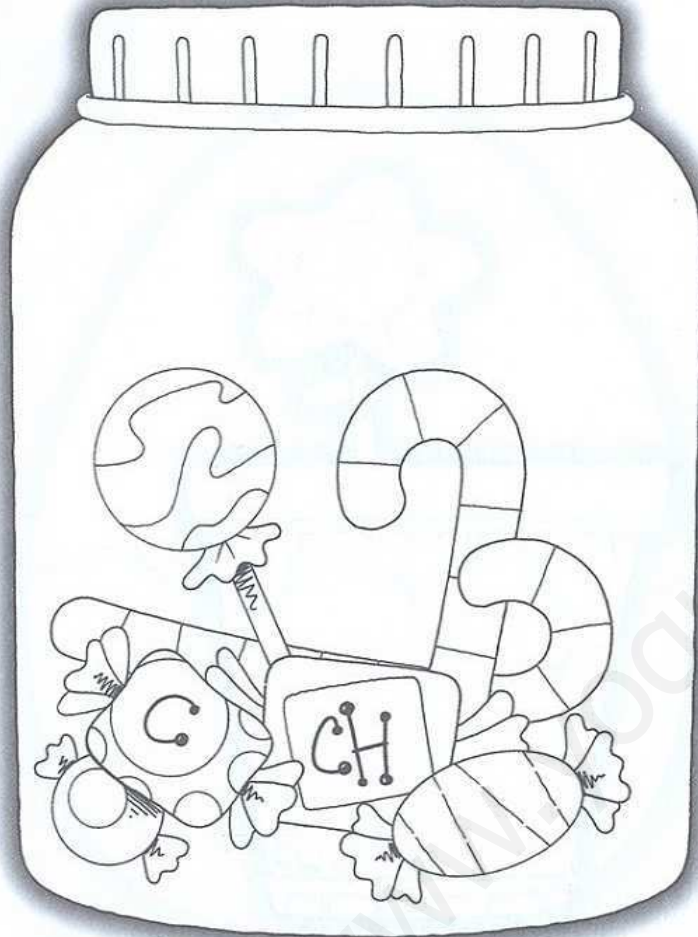

Actividad: Colorea el bote que tiene muchos caramelos.

Consejo: El niño o la niña utilizará esta noción de cantidad en sus actividades cotidianas. Por ejemplo: "colocará muchos juguetes en un baúl y pocos juguetes en una estantería de pared dentro de su habitación". "Colocará muchos tenedores en un cajón y pocos tenedores en otro ...". Se trata de que manipule el concepto "muchos-pocos".



DO 1 AO 10

¡HOLA! ¿QUIERES PRESENTARTE?

- DIBUJA TU ROSTRO.
- PIDE AYUDA Y ANÍMATE A COMPLETAR TUS DATOS PERSONALES.

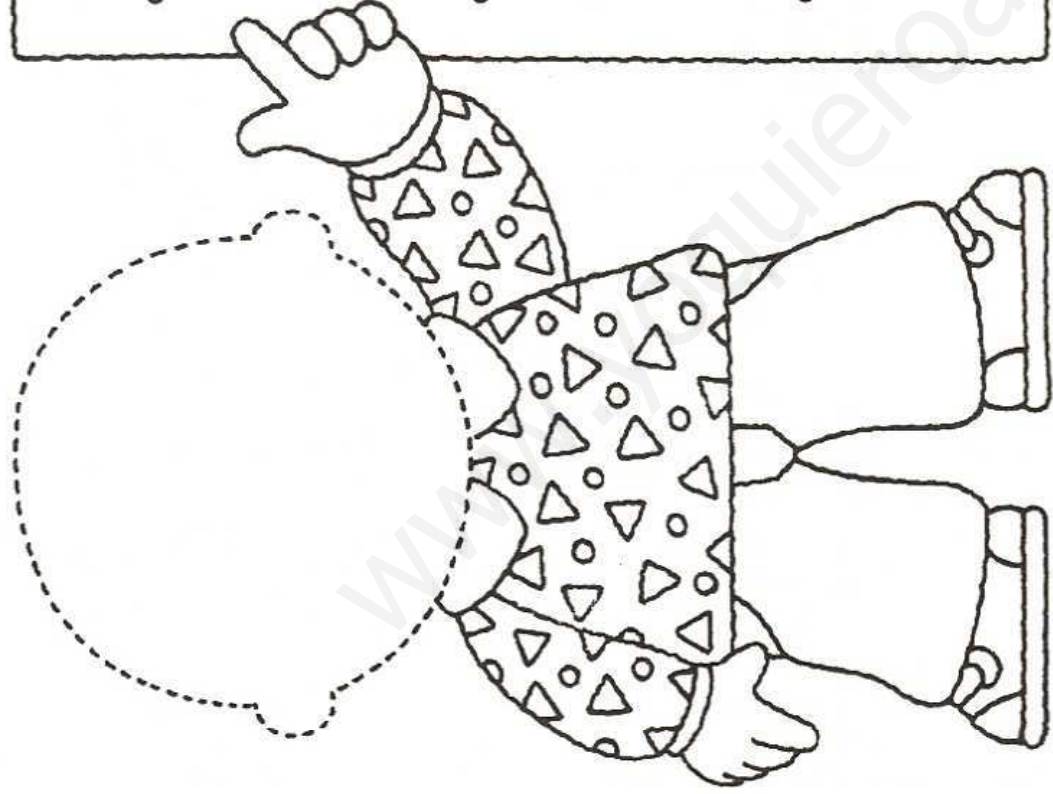

• TENGO AÑOS

• TENGO HERMANOS

• PESO KILOS

• ¿CUÁNTOS TIENES?

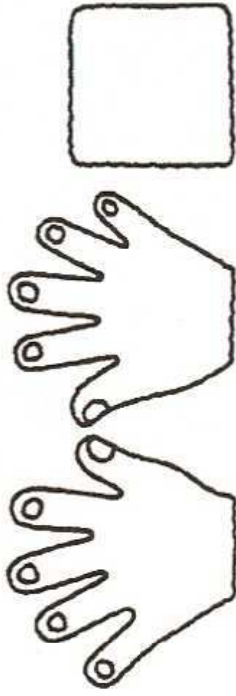
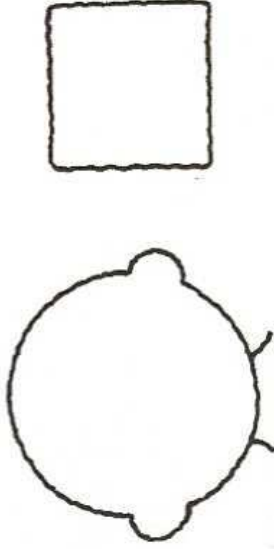
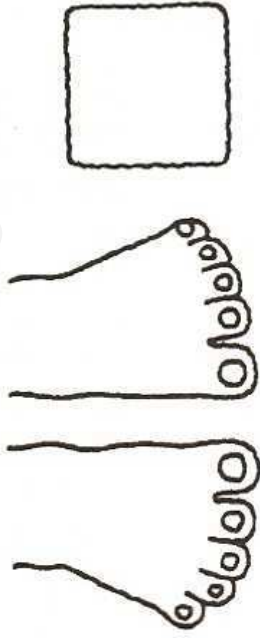
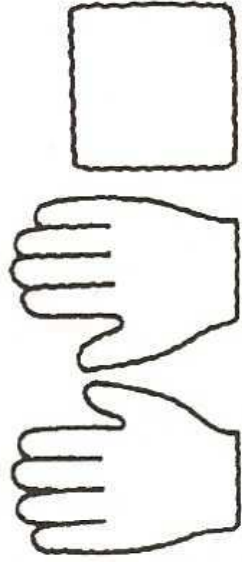
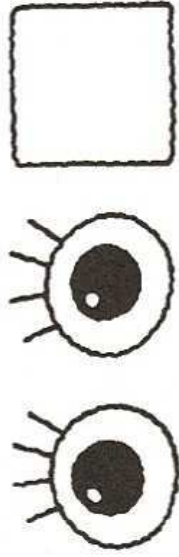

¡MUCHOS, MUCHOS! ¡POCOS, POCOS!

2

• COLOREA EL LEOPARDO QUE TIENE **MUCHAS** MANCHAS.

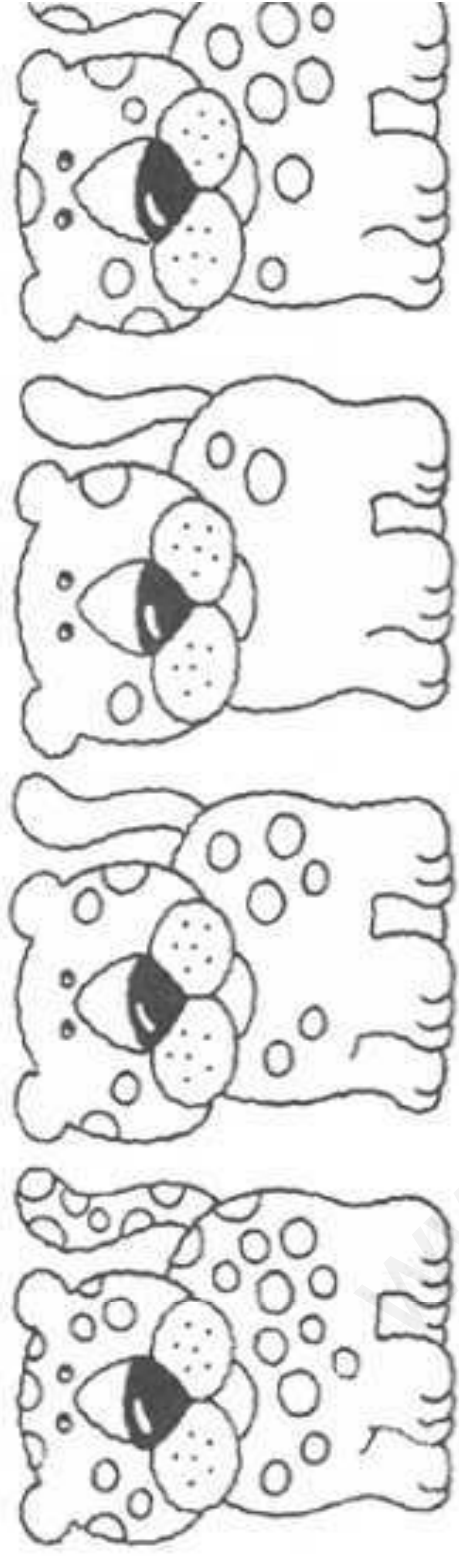

• COLOREA LA NUBE QUE TIENE **POCAS** GOTAS.



• COLOREA EL QUESO QUE TIENE **MUCHOS** AGUJEROS.

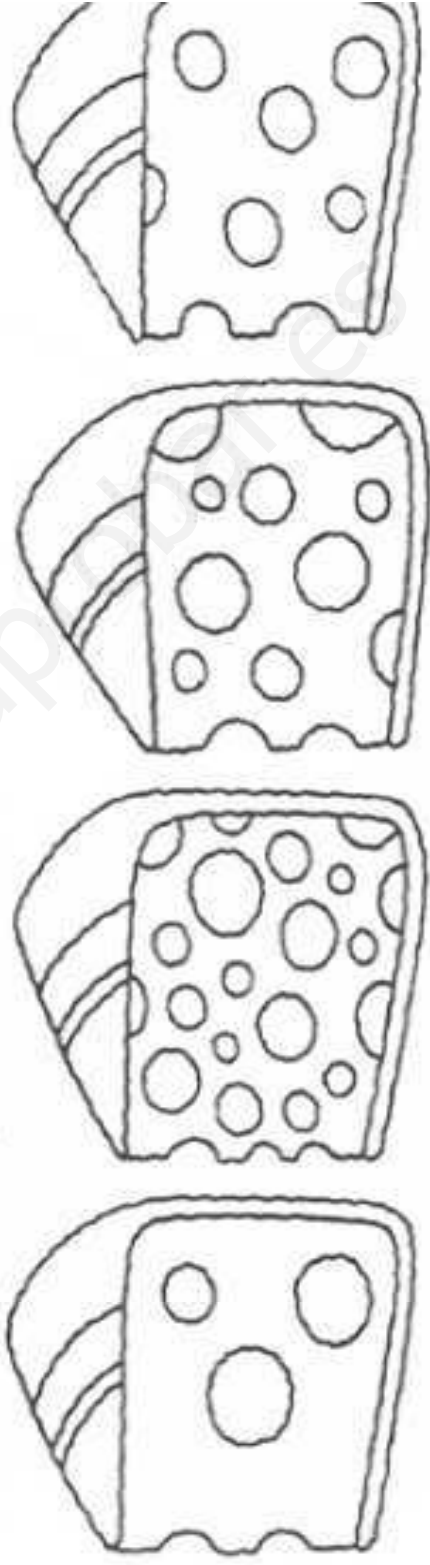

• COLOREA LA FRUTILLA QUE TIENE **POCAS** SEMILLAS.

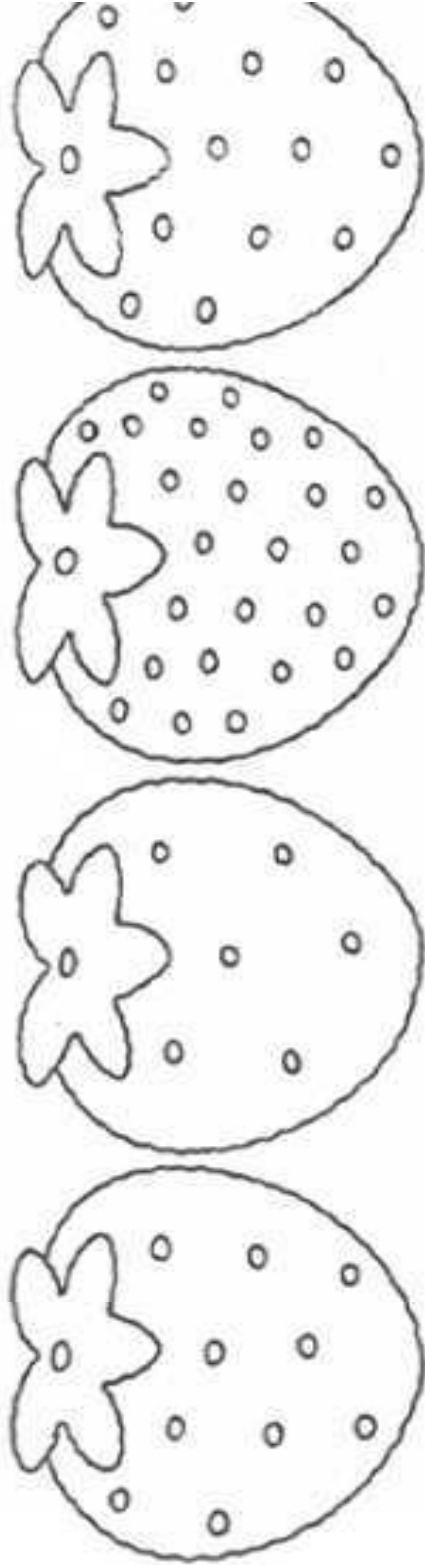

¿TE ANIMAS A ESCRIBIR NÚMEROS Y LETRAS **ADENTRO** DE LAS BOLSAS

CORRESPONDIENTES?

• COLOREA LA IMAGEN.

3

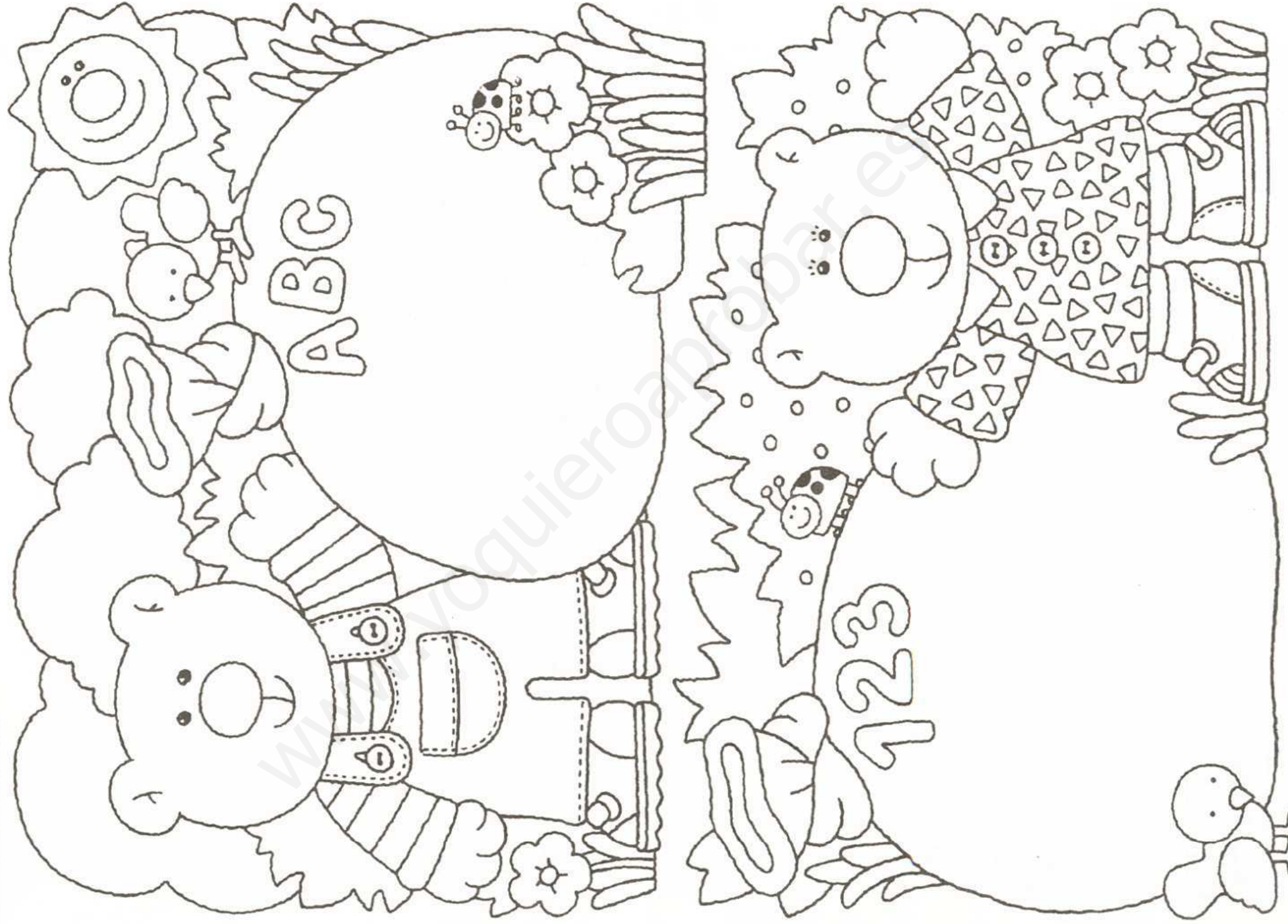

• ¿PUEDES DECIR EL NOMBRE DE CADA ANIMAL?

• OBSERVA LAS PATAS Y UNE CON UNA LÍNEA LOS QUE TIENEN LA MISMA CANTIDA

4

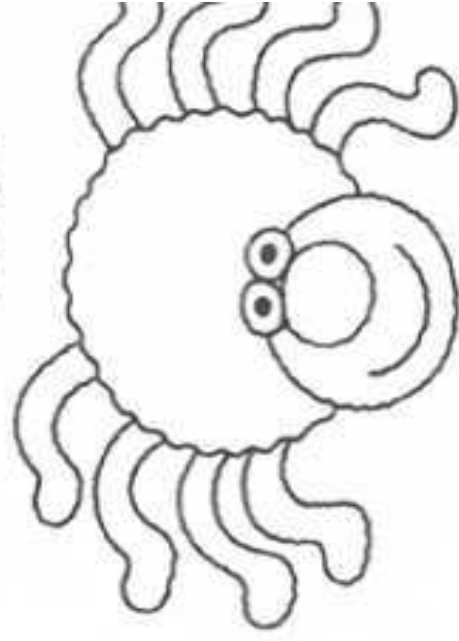
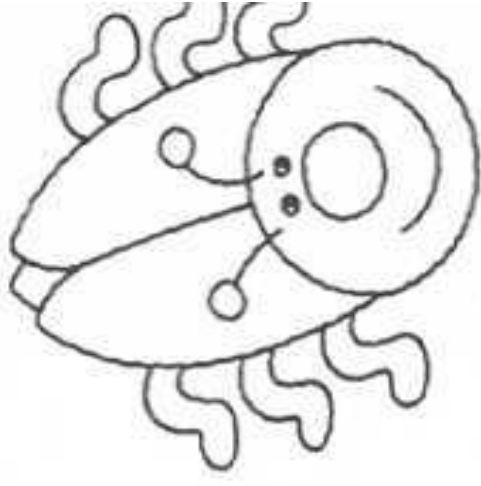
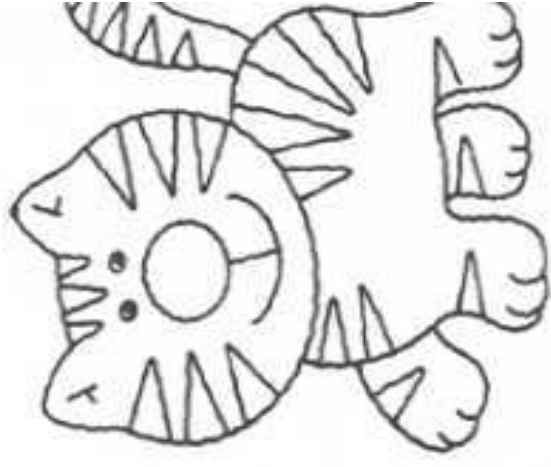
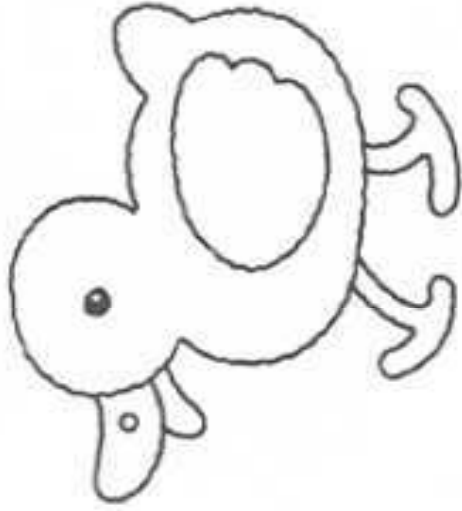

¡A DECORAR TRAJES CON ESTRELLAS Y PARCHES!

- LOS DE LA DERECHA TIENEN MENOS QUE LOS DEL MEDIO.
- LOS DE LA IZQUIERDA TIENEN MÁS QUE LOS DEL MEDIO.

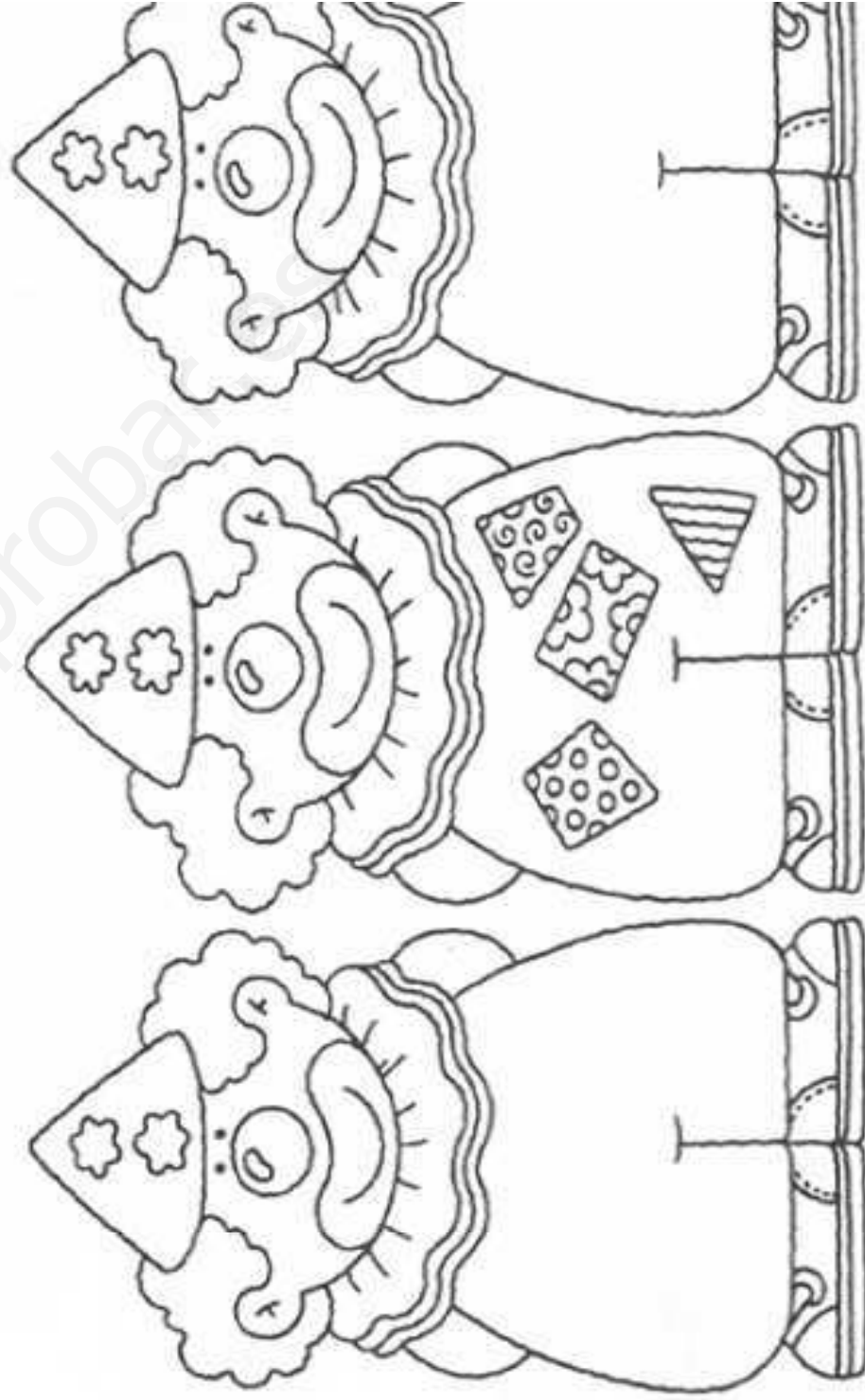
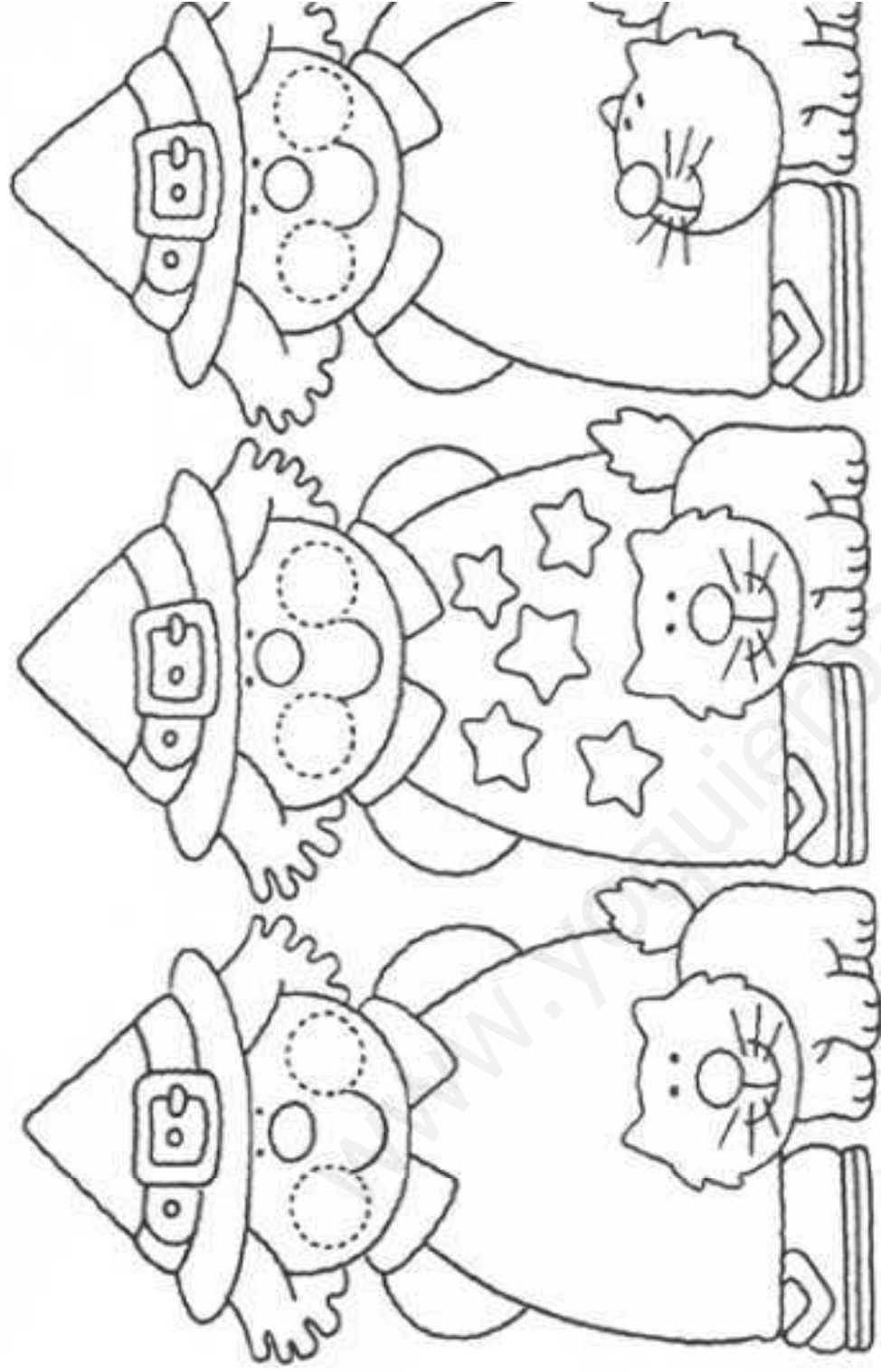

¡UNO DIFERENTE!

OBSERVA, DESCÚBRELO Y LUEGO COLOREALO EN CADA HILERA.

6

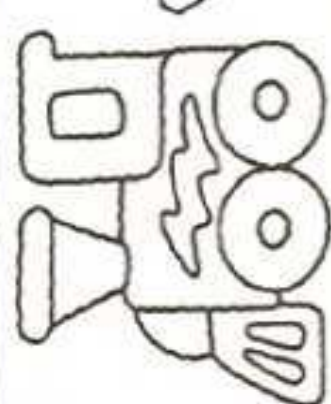
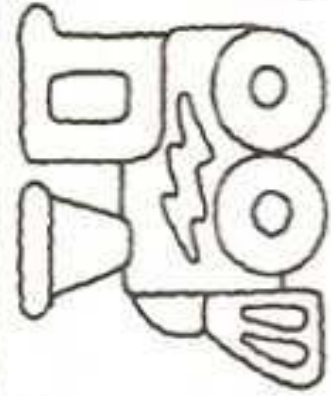
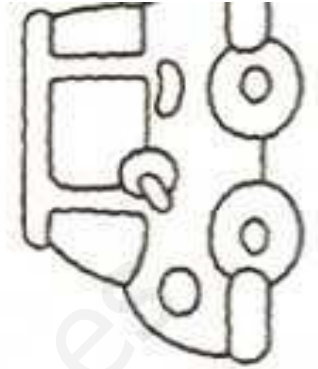
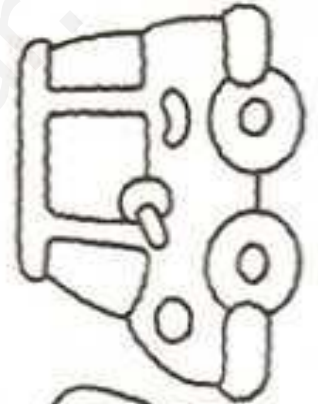
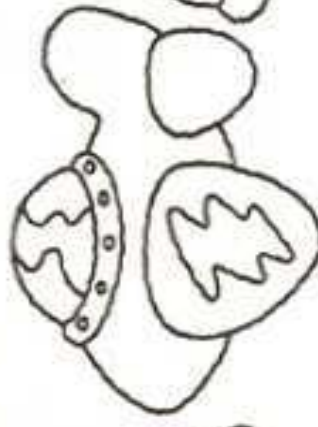
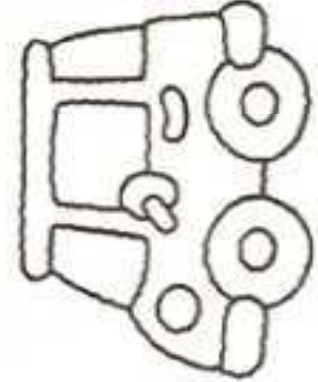
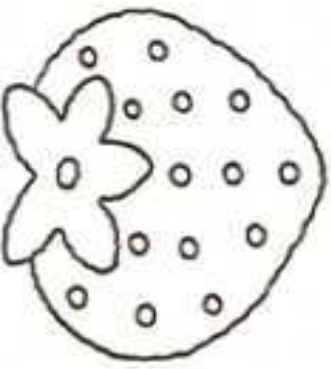
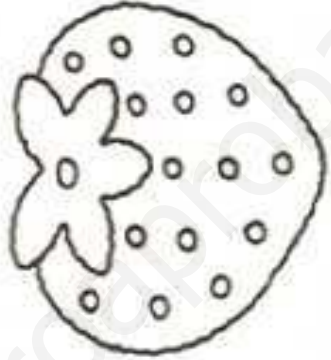
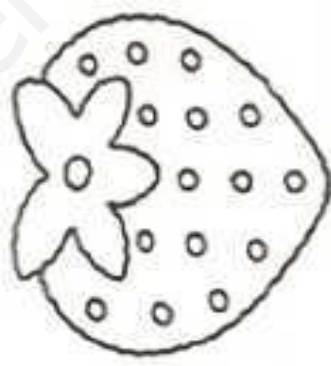
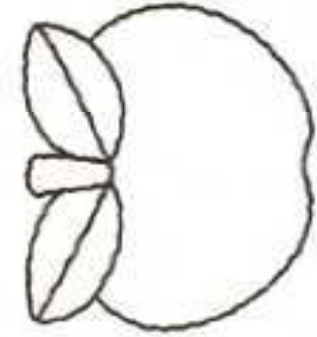
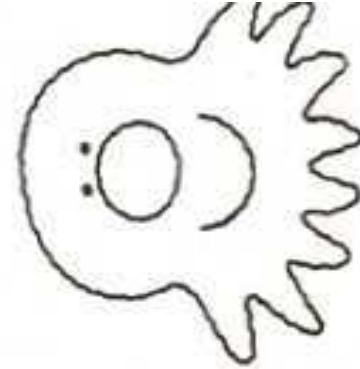
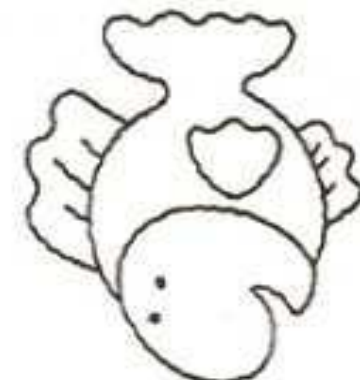
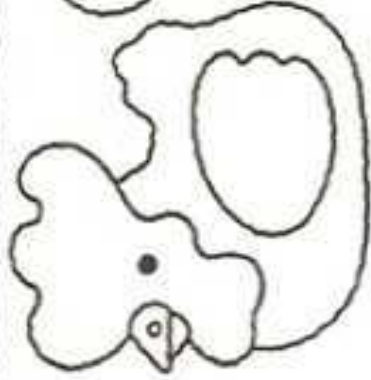
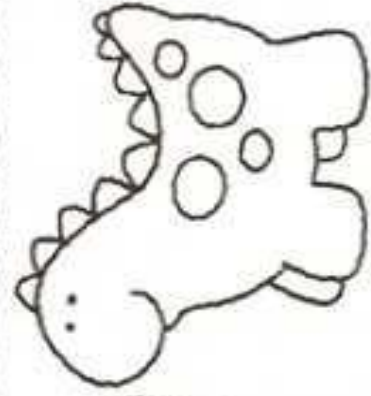
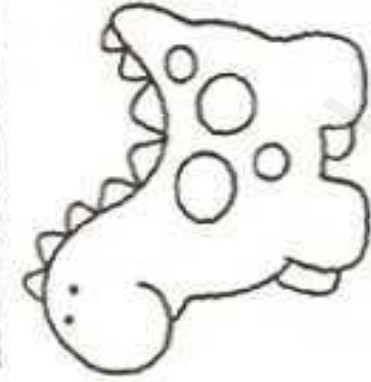

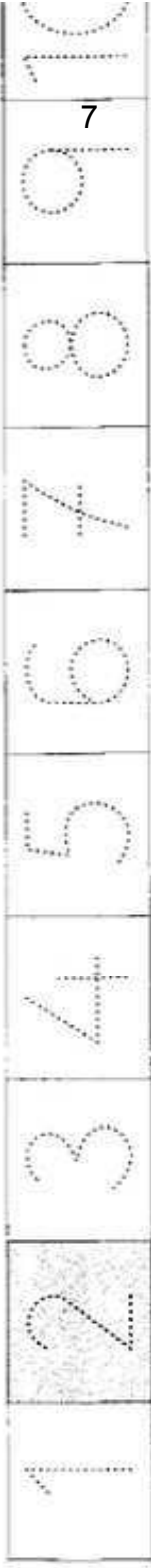

- RECORRE VARIAS VECES EL NÚMERO CON TU DEDO ÍNDICE.
- DECÓRALO CON PAPELITOS DE COLOR CORTADOS CON TIJERA.

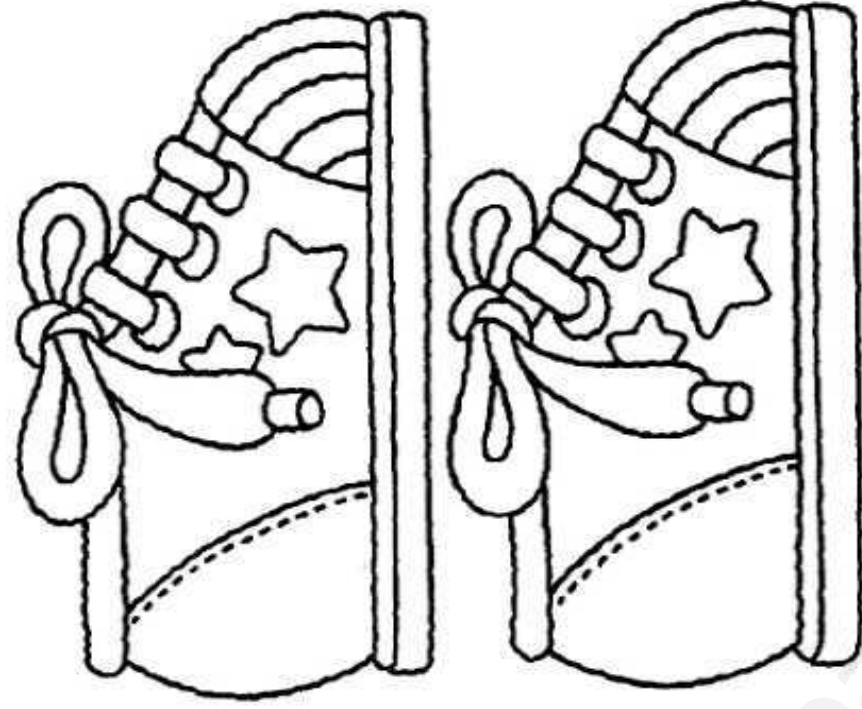
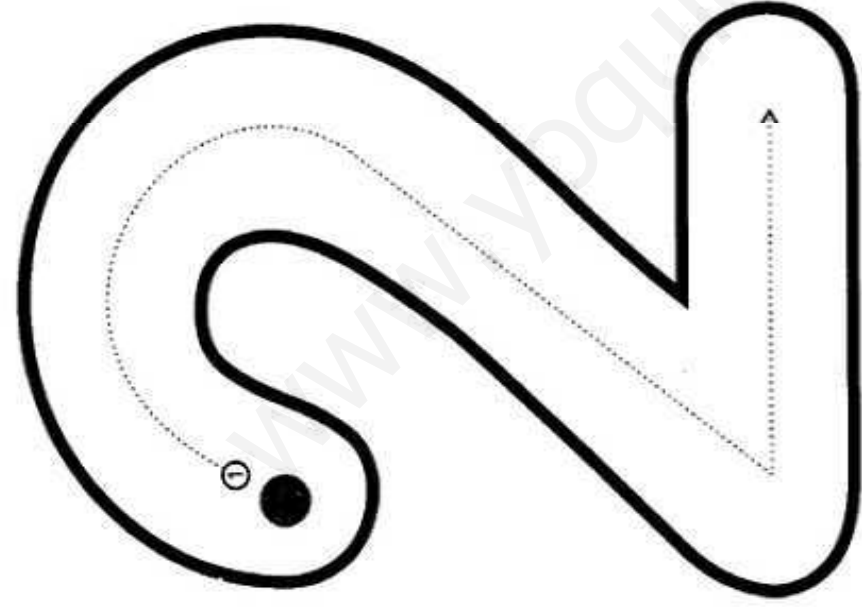

DOS

- DELINEA Y COMPLETA CADA RENGLÓN.

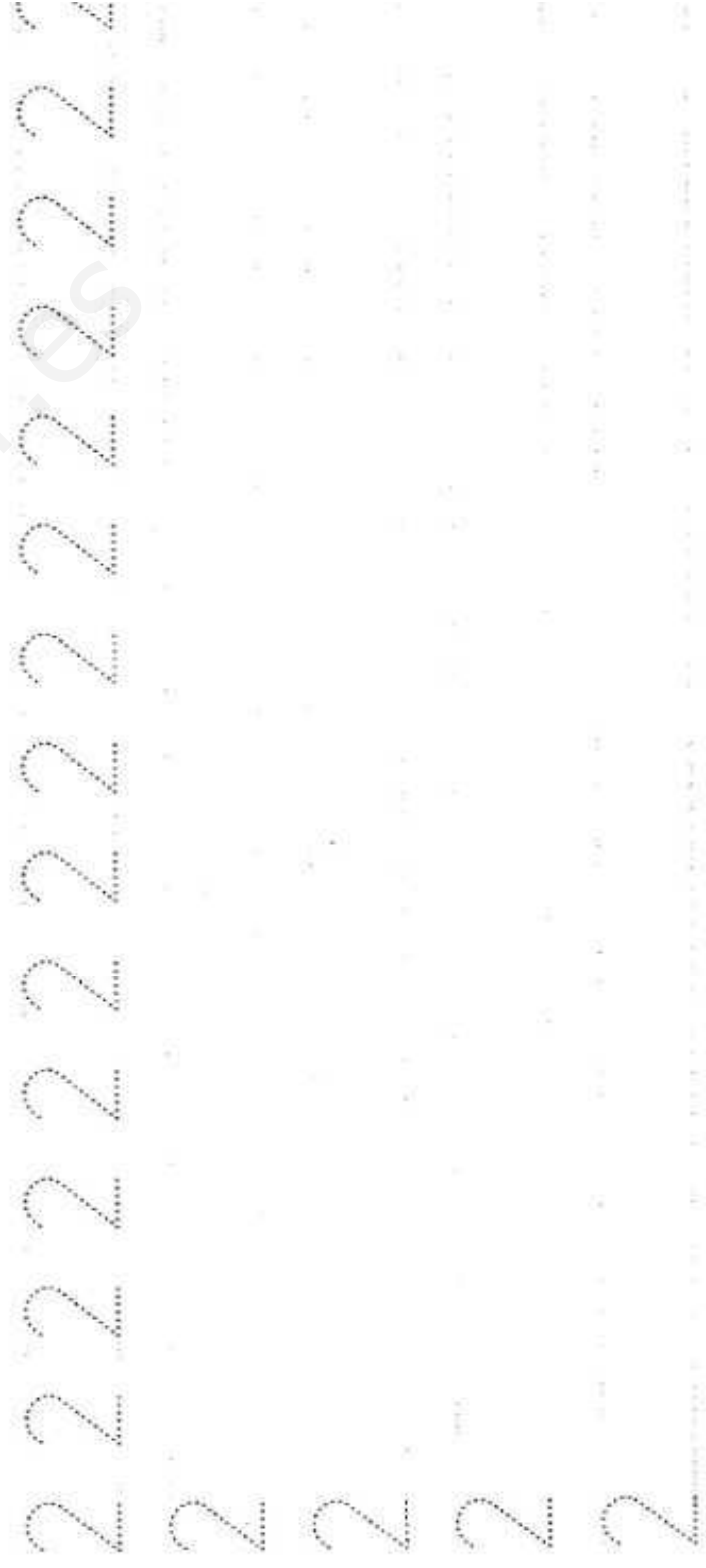

¿SON TODOS ANIMALES SALVAJES!

- REPITE EN VOZ ALTA EL NOMBRE Y EL SONIDO DE CADA ANIMAL.
- DESCUBRE Y COLOREA LOS **DOS** QUE SON IGUALES EN CADA HILERA.

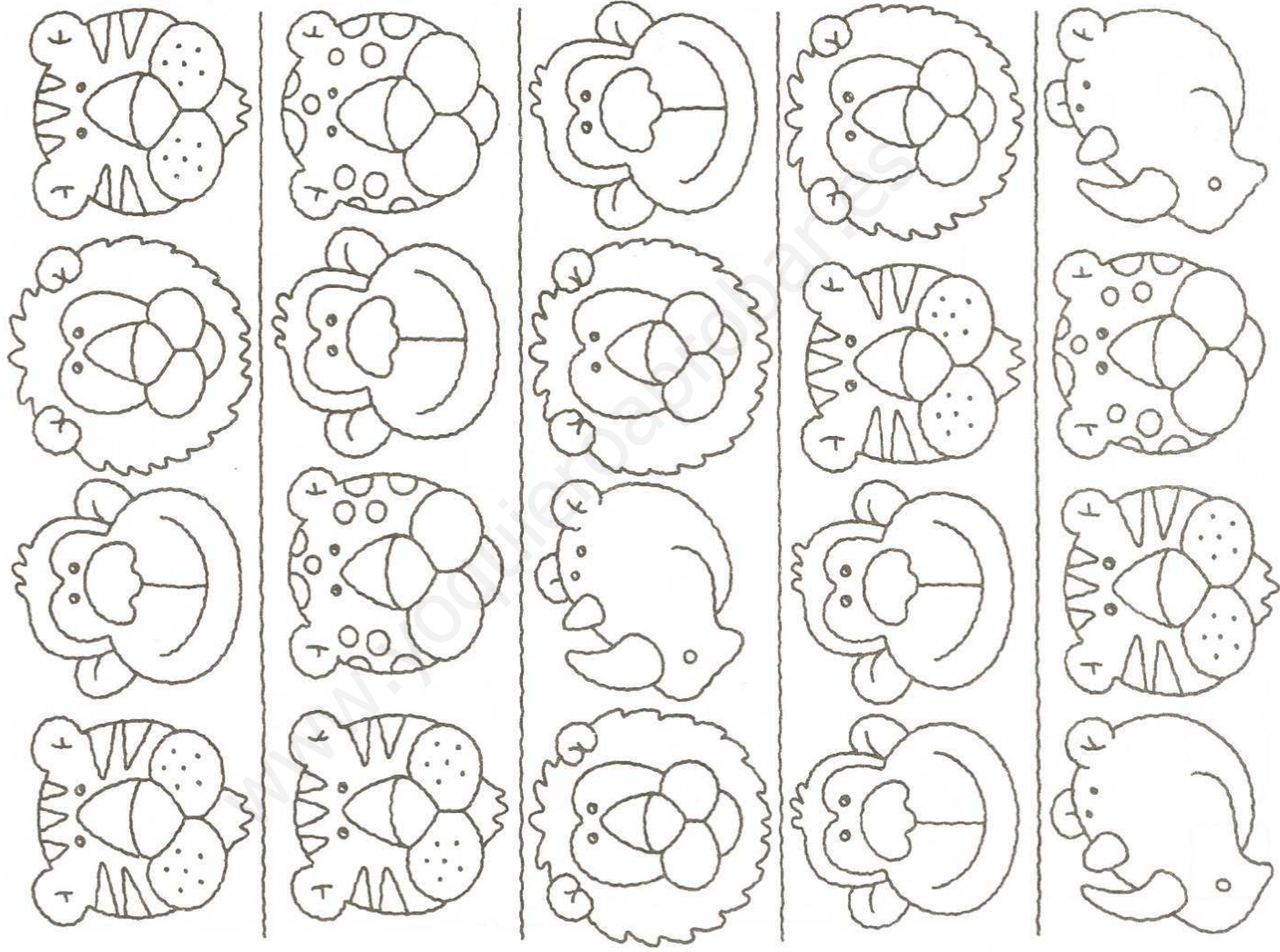

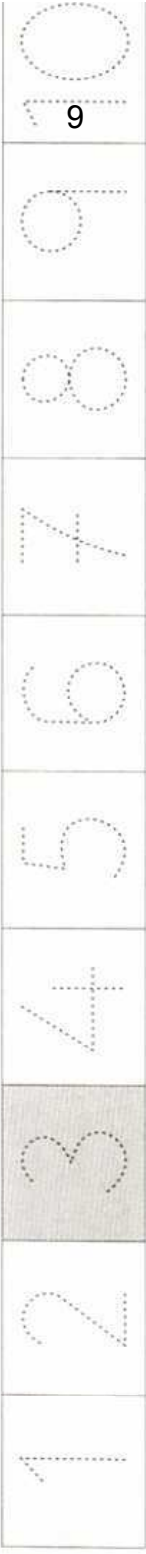

- RECORRE VARIAS VECES EL NÚMERO CON TU DEDO ÍNDICE.
- COLORÉALO SIGUIENDO LA DIRECCIÓN CORRECTA.

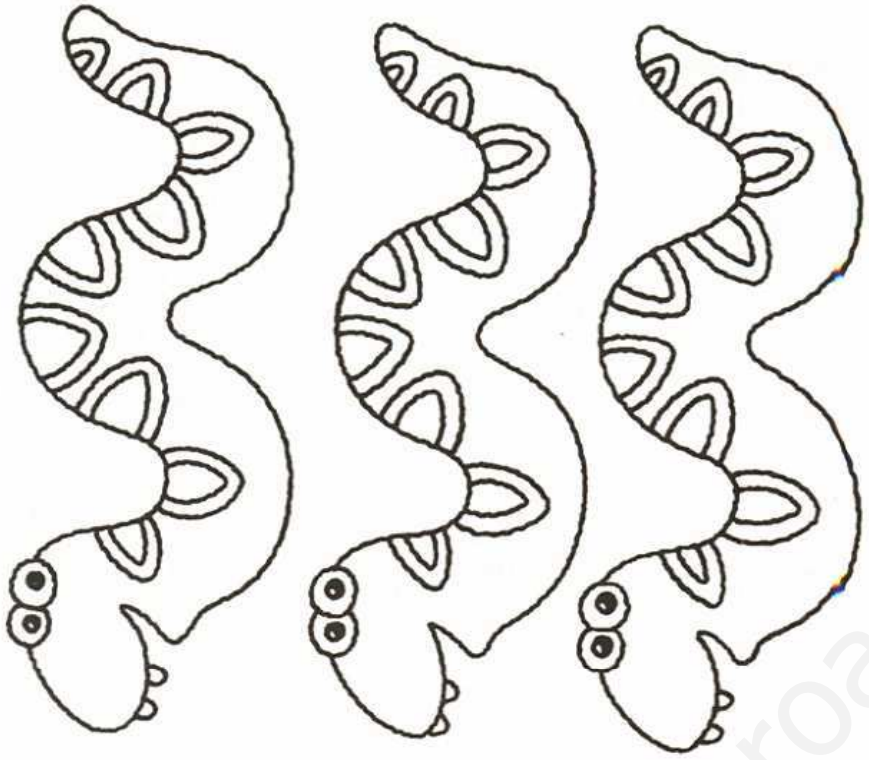
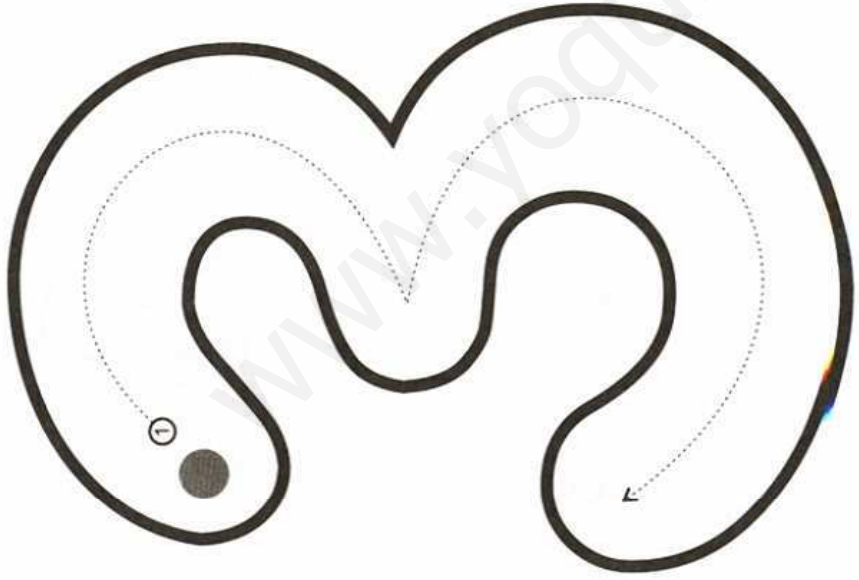

TRES

- DELINEA Y COMPLETA CADA RENGLÓN.



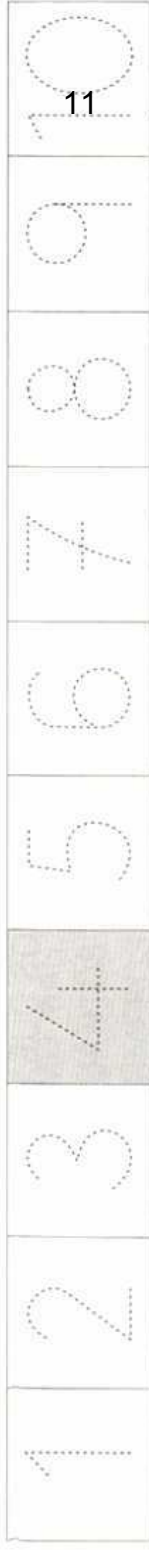

- RECORRE VARIAS VECES EL NÚMERO CON TU DEDO ÍNDICE.
- DECÓRALO CON CUATRO COLORES ALTERNADOS.

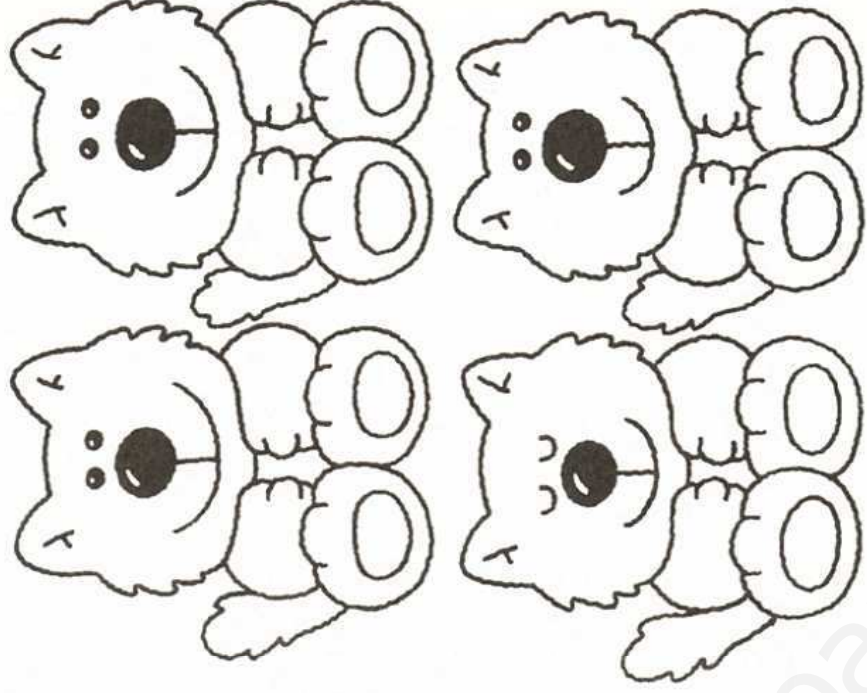
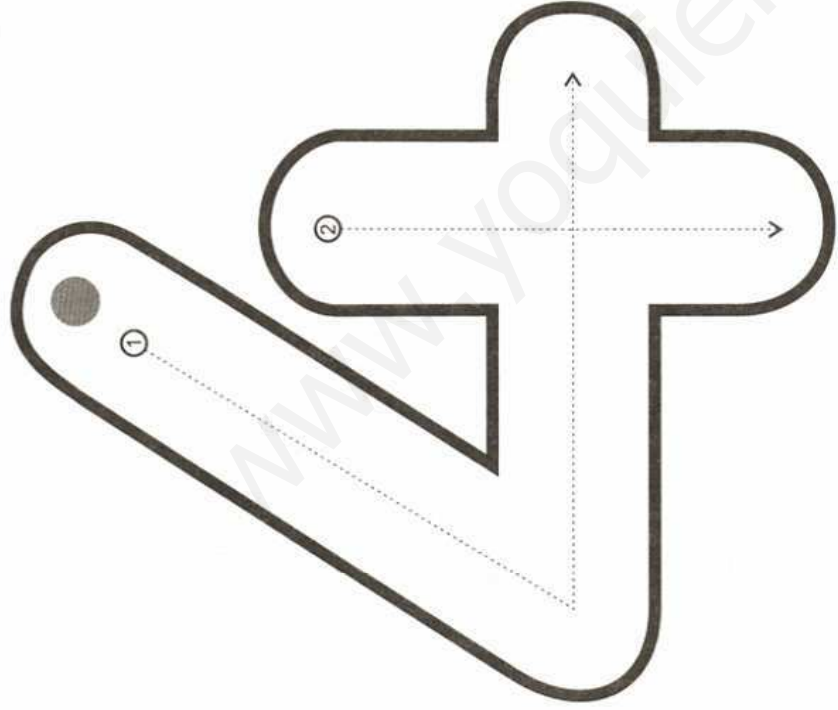

CUATRO

- DELINEA Y COMPLETA CADA RENGLÓN.

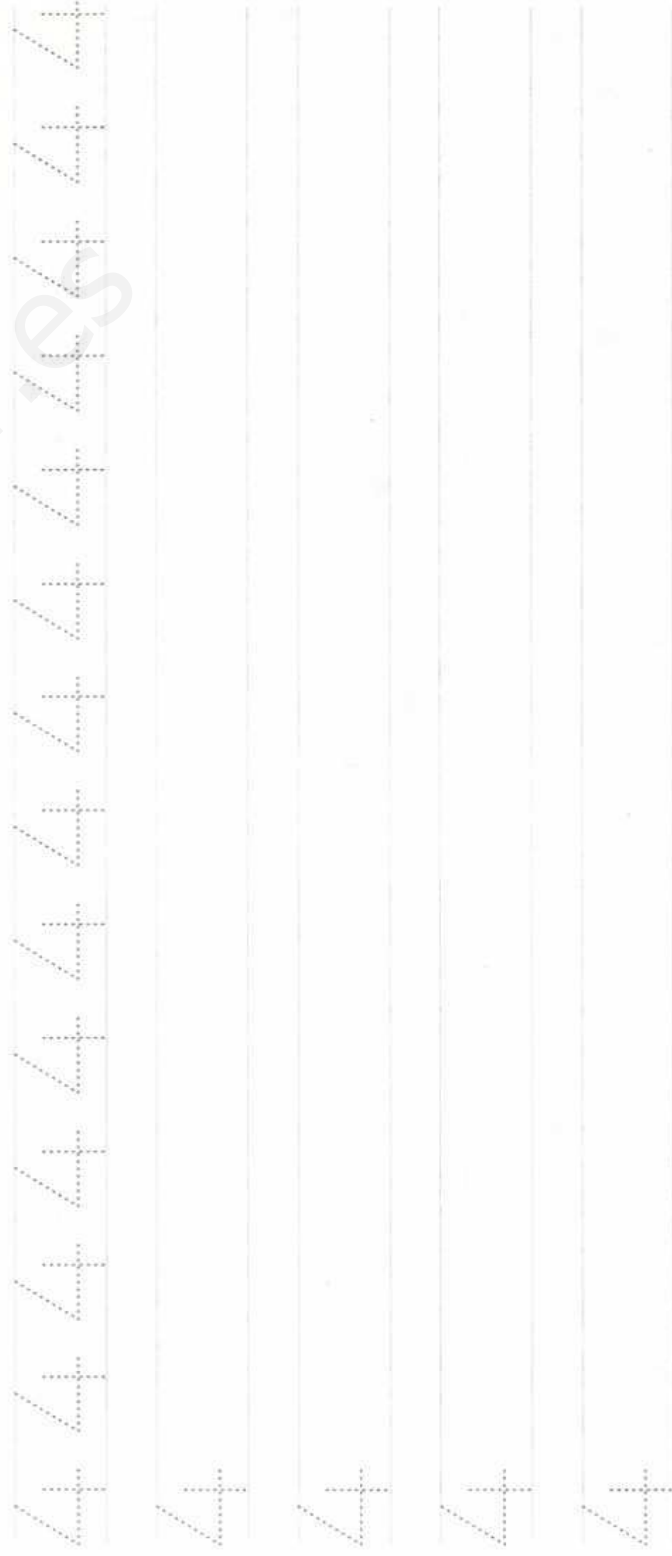

• DECORA CADA NÚMERO SIGUIENDO LA DIRECCIÓN CORRECTA.

• COLOREA EN CADA FICHA **TANTOS** OBJETOS **COMO** INDICA EL NÚMERO.

12

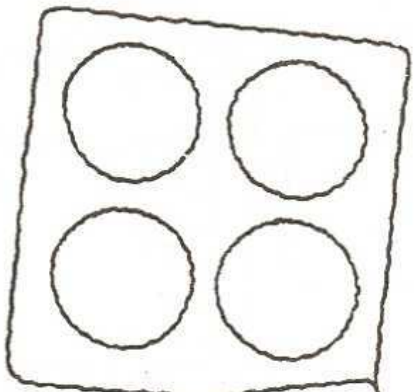
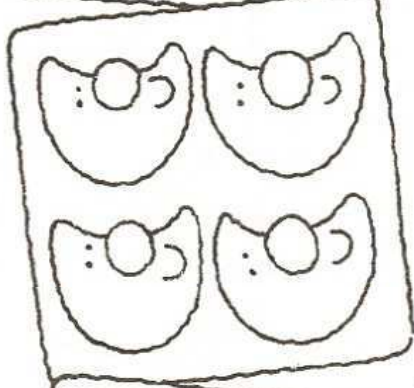
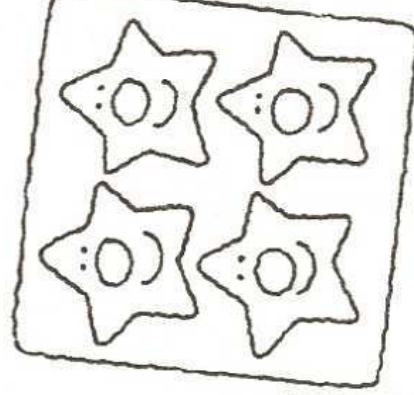
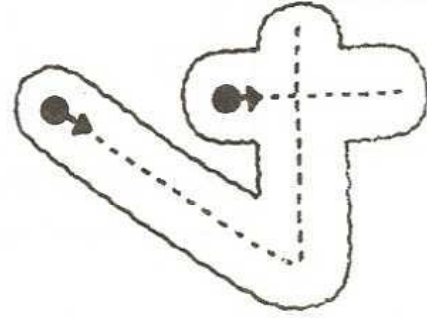
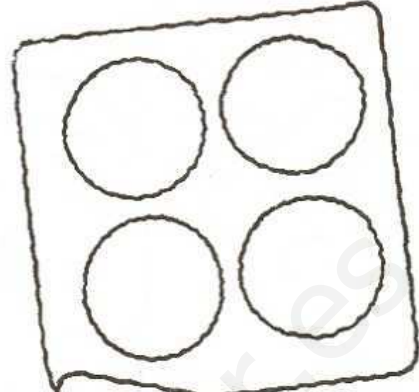
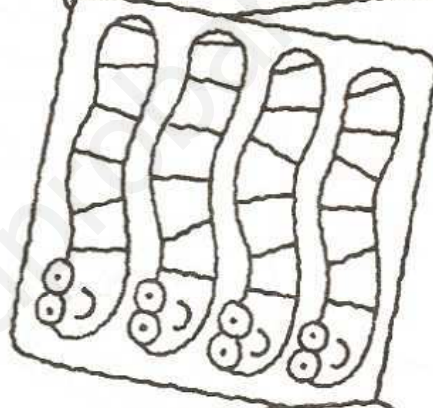
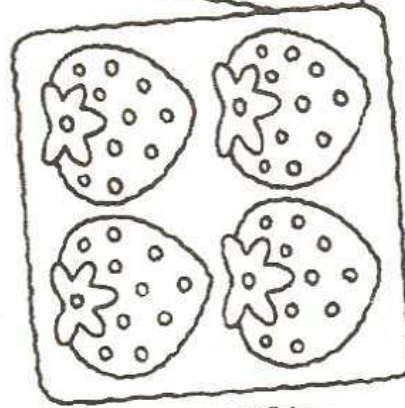
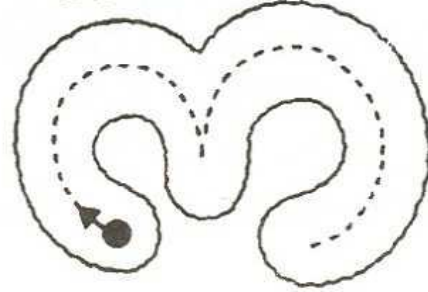
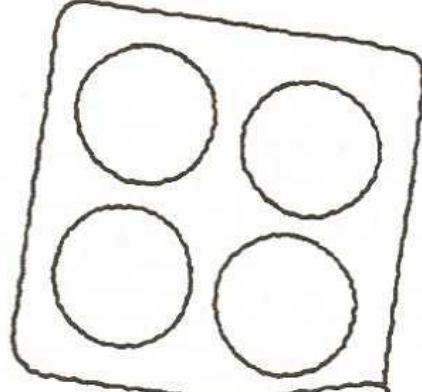
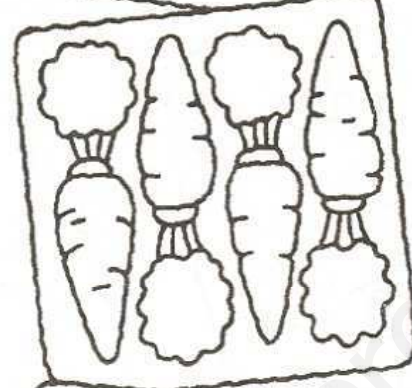
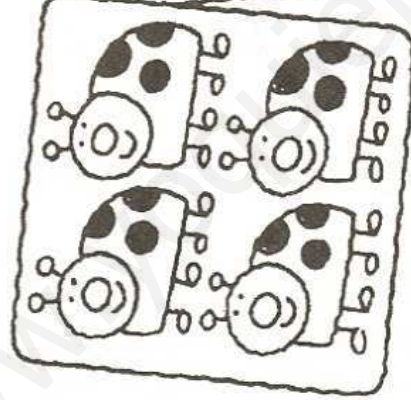
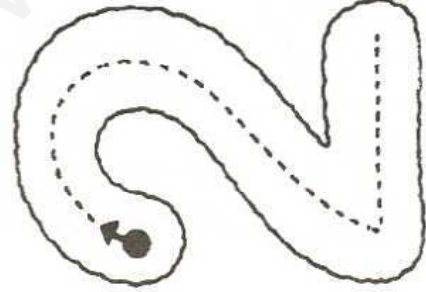
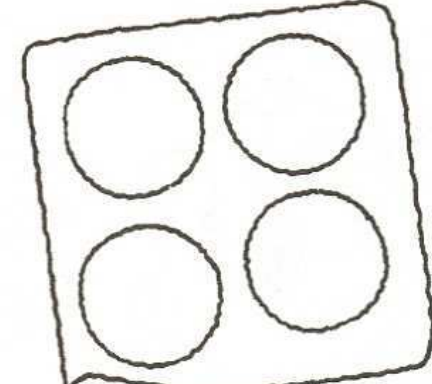
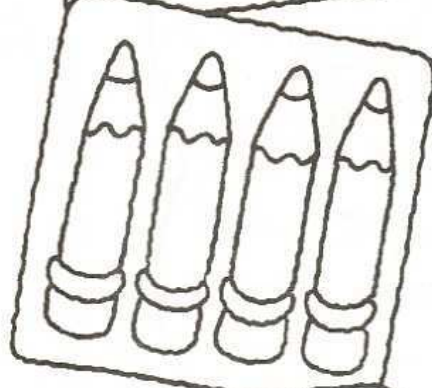
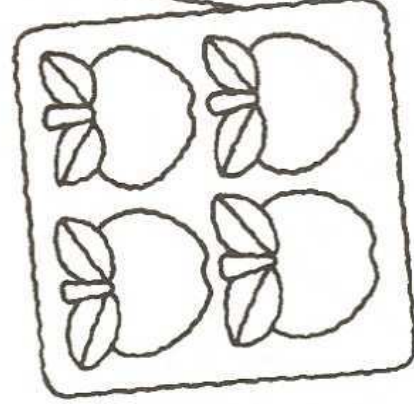
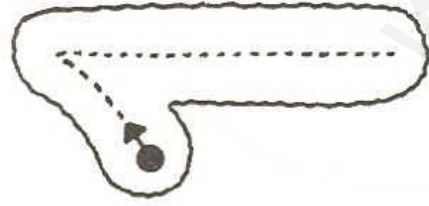

- RECORRE VARIAS VECES EL NÚMERO CON TU DEDO ÍNDICE.
- DECÓRALO CON LUNARES DE COLORES.

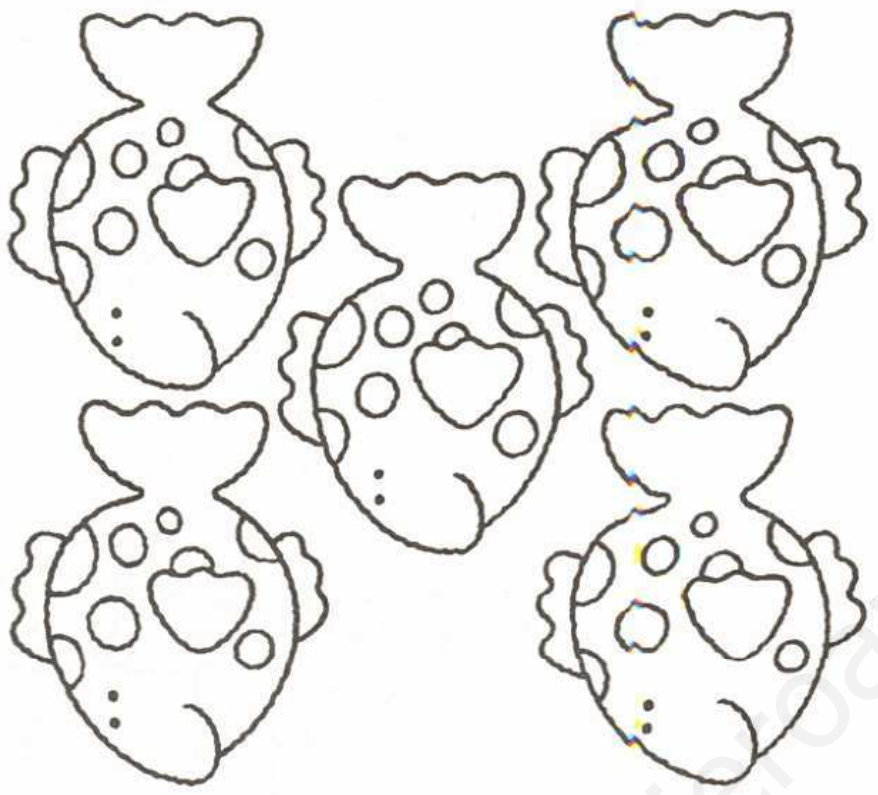
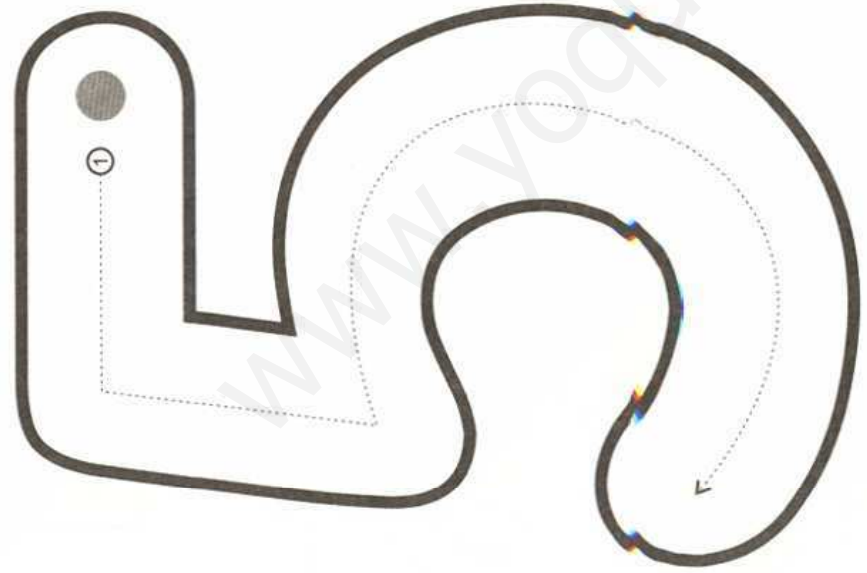

CINCO

- DELINEA Y COMPLETA CADA RENGLÓN.

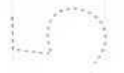
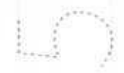

- COLOREA LAS TARJETAS QUE TIENEN CINCO ELEMENTOS.
- ¿HAY MÁS GOTTITAS QUE GUSANOS? ¿HAY MENOS PERROS QUE ...?

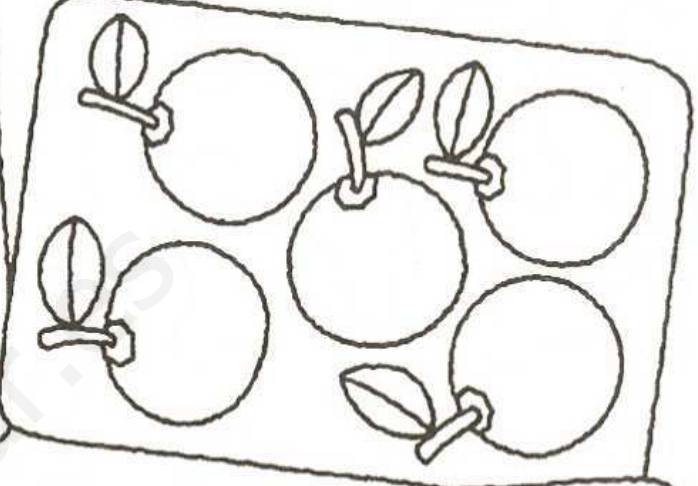
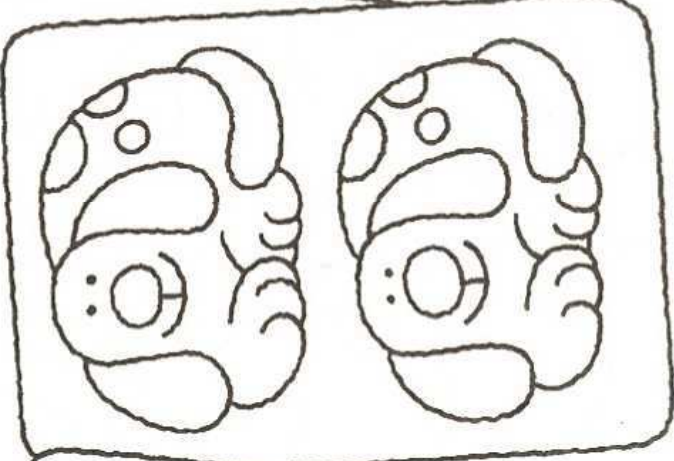
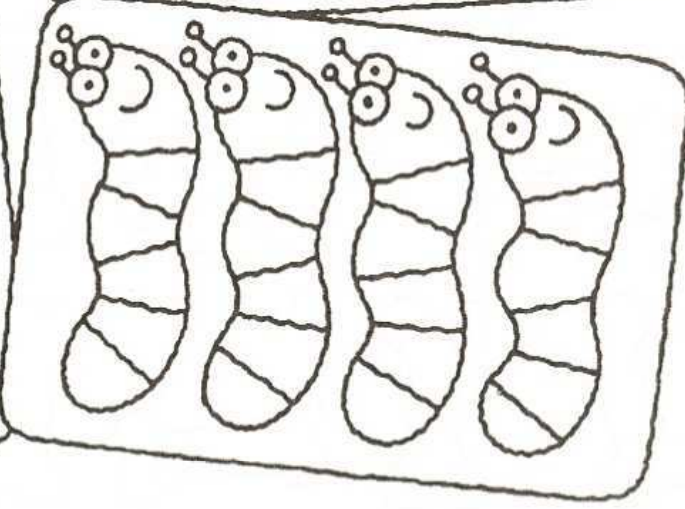
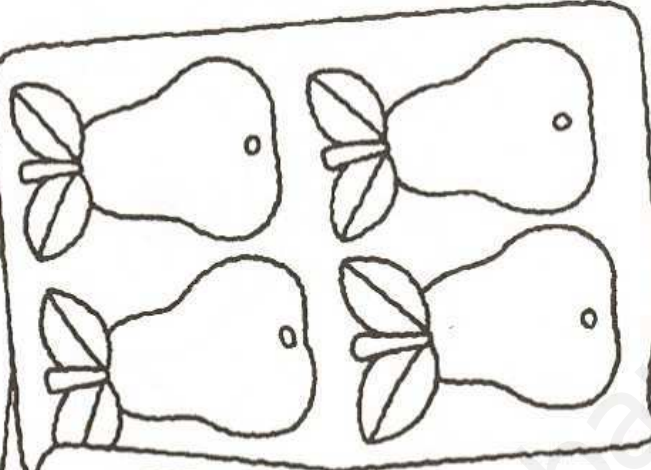
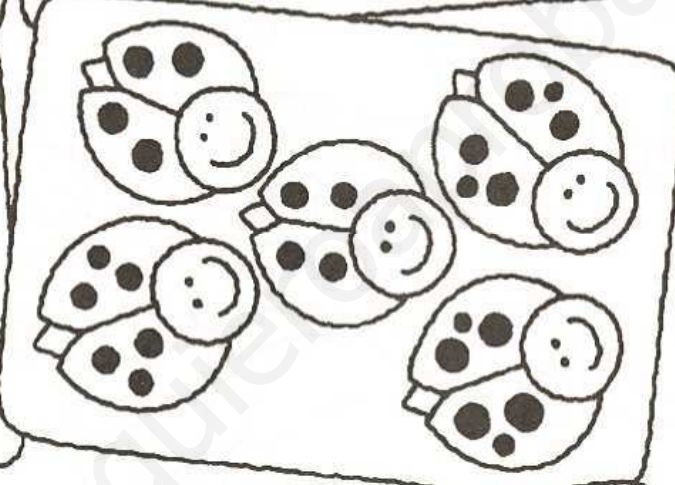
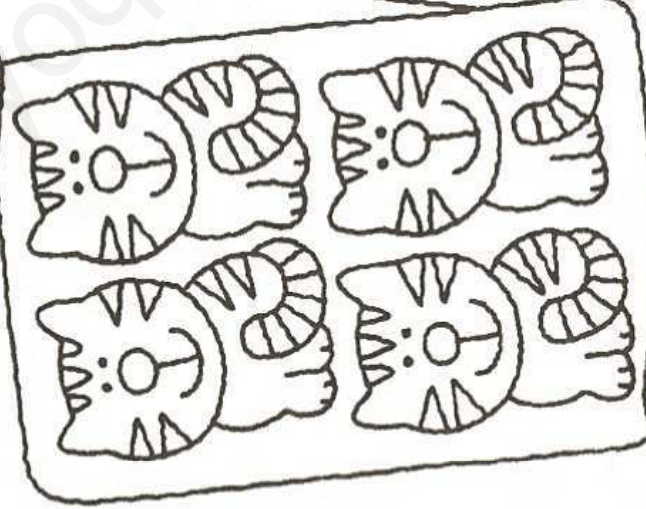
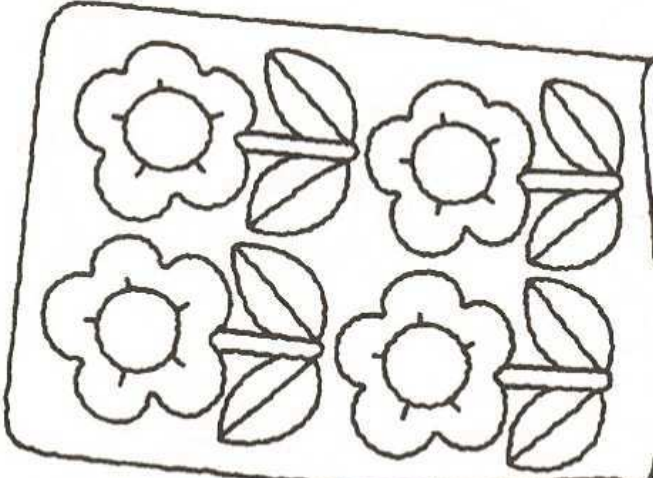
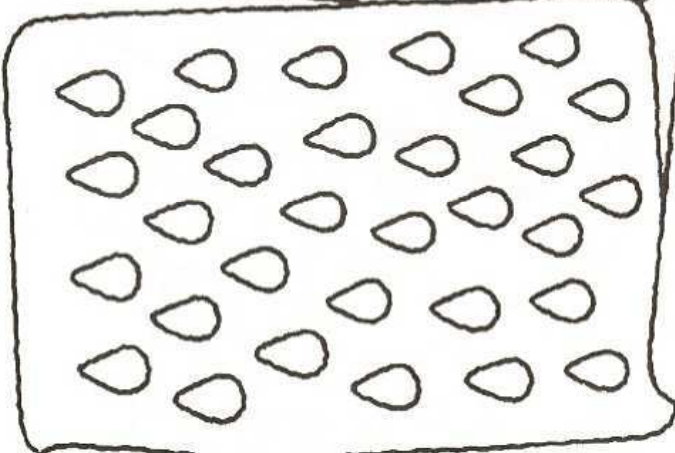
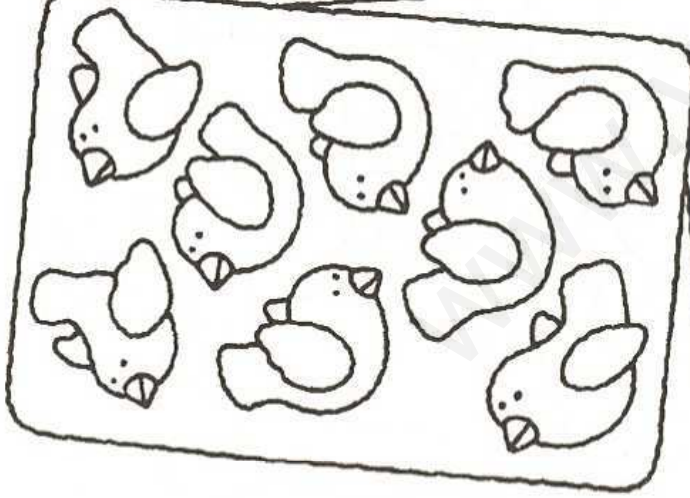

¿QUÉ PASOS SIGUEN LOS OSITOS PARA VESTIRSE?

- ESCRIBE LOS NÚMEROS DEL 1 AL 4 SEGÚN EL ORDEN EN QUE LO HACEN.

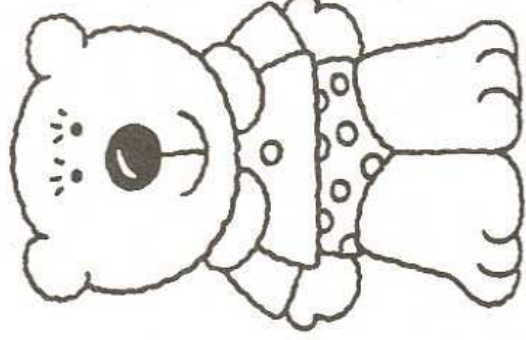
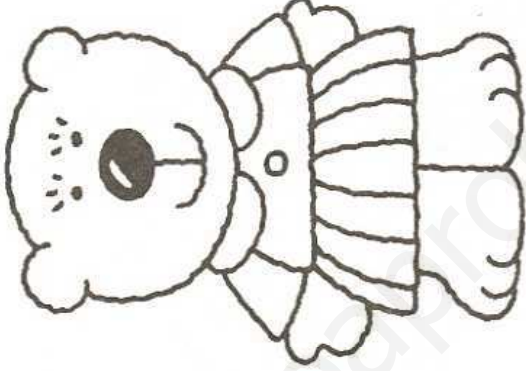
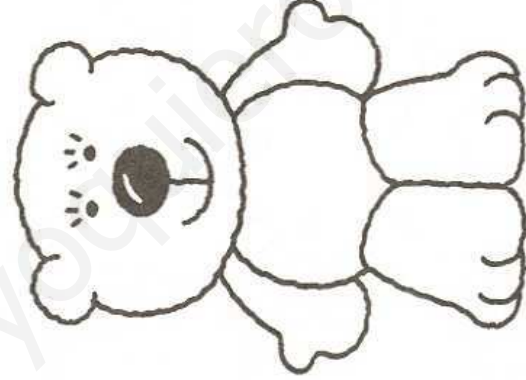
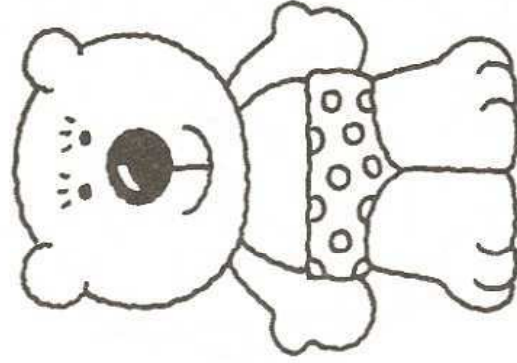
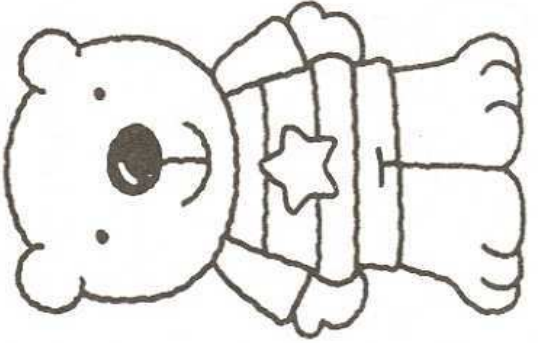
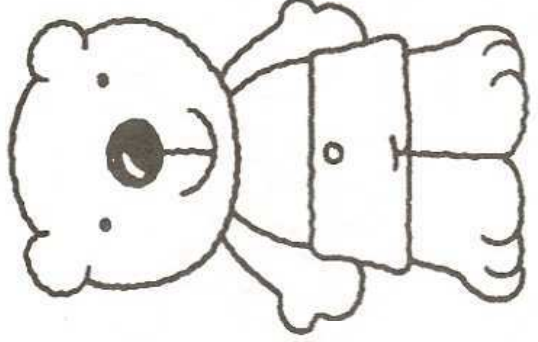
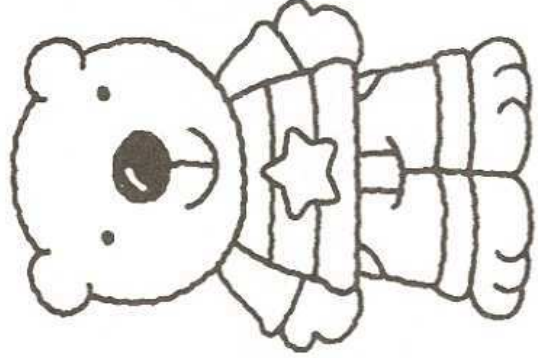
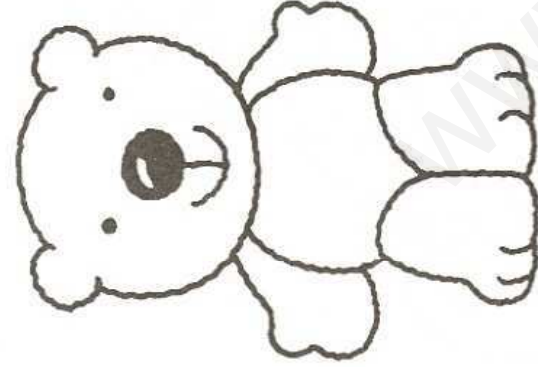

- AHORA, VÍSTELOS TÚ SOLO SIGUIENDO EL ORDEN DEL PRIMERO AL ÚLTIMO.

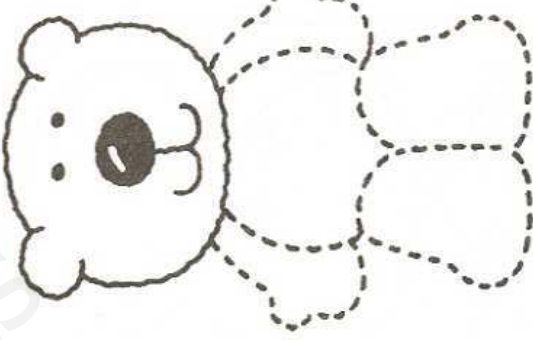
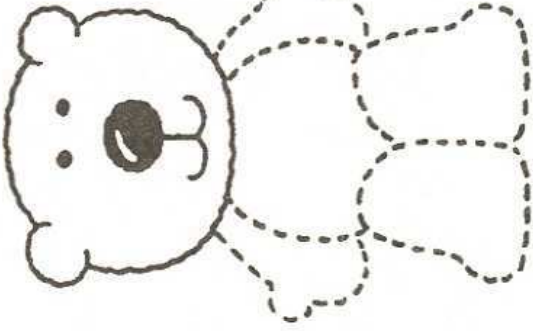
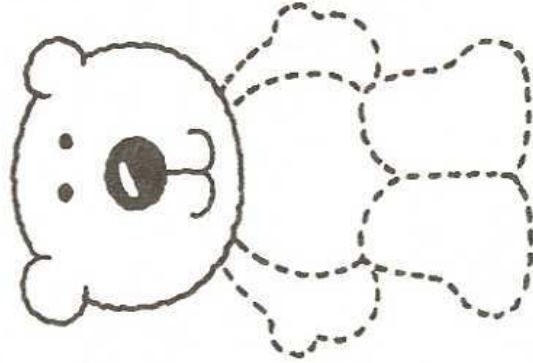
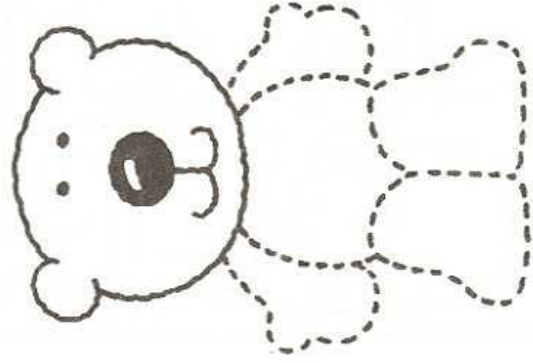

1

2

3

4

A CADA FLOR LE CORRESPONDEN TANTAS ABEJAS COMO INDICA SU NÚMERO.

• SEÑALA CON UN COLOR DIFERENTE CADA CAMINO PARA LLEGAR A SU FLOR.

• COLOREA LOS NÚMEROS Y LAS FLORES.

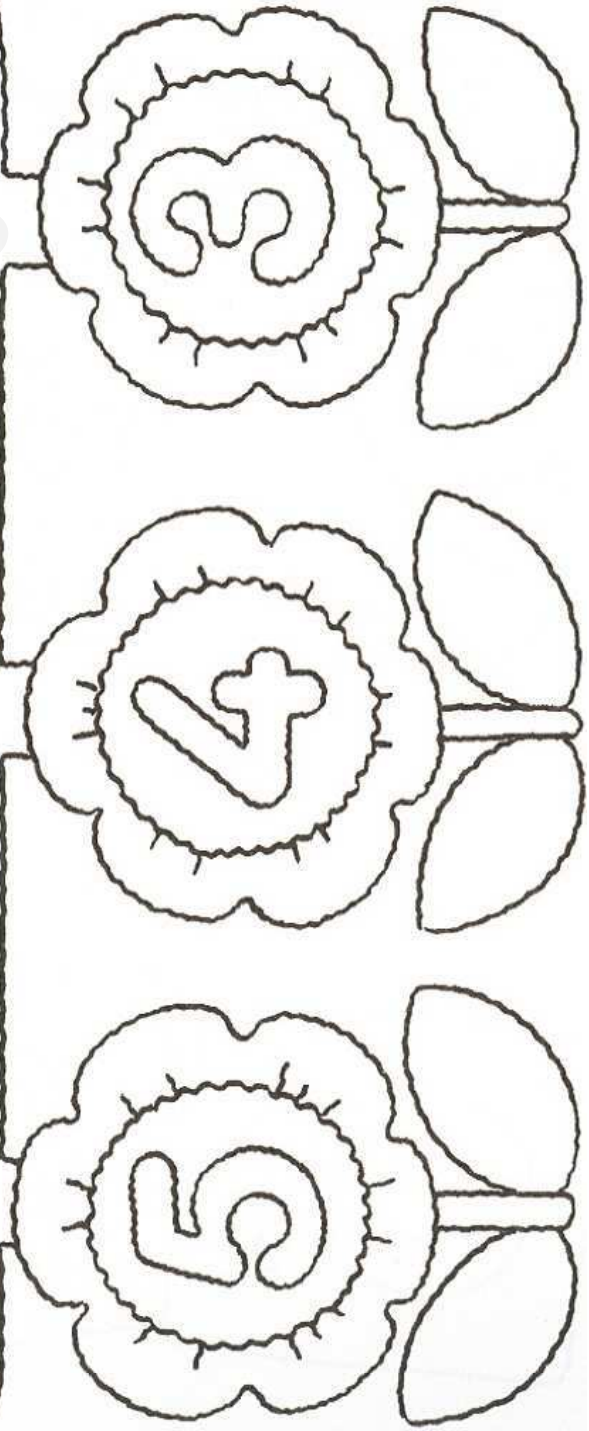
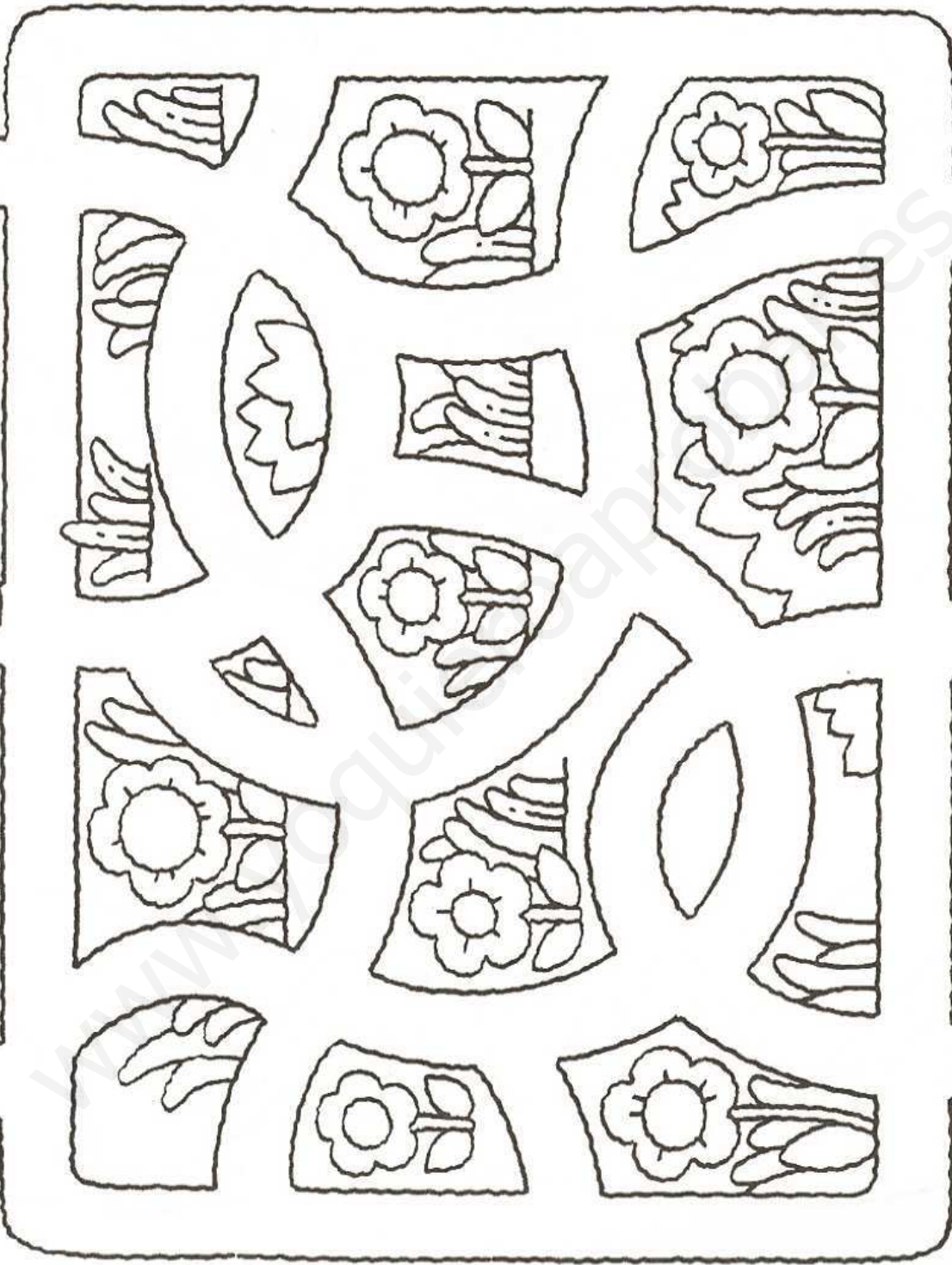
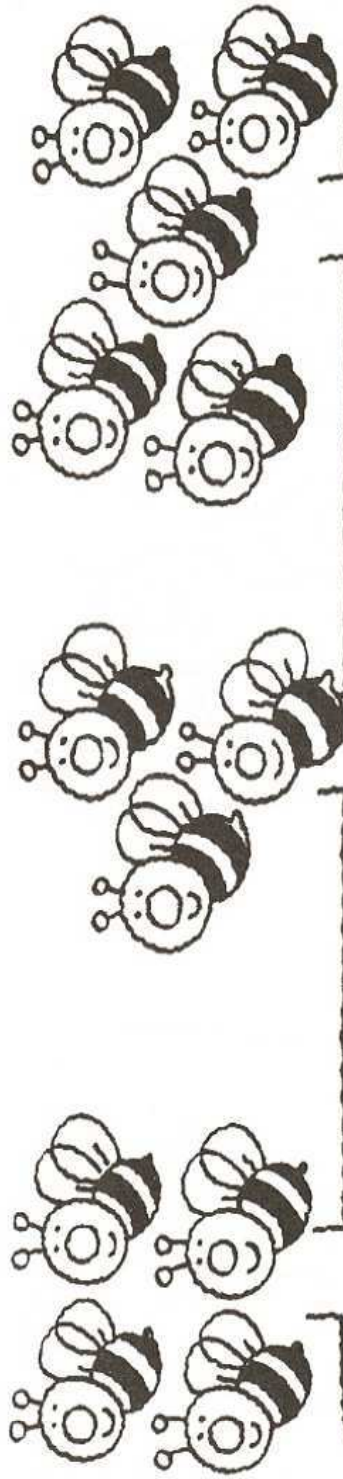

1 2 3 4 5 6 7 8 9 10

- RECORRE VARIAS VECES EL NÚMERO CON TU DEDO ÍNDICE.
- DECÓRALO CON BRILLANTINA.

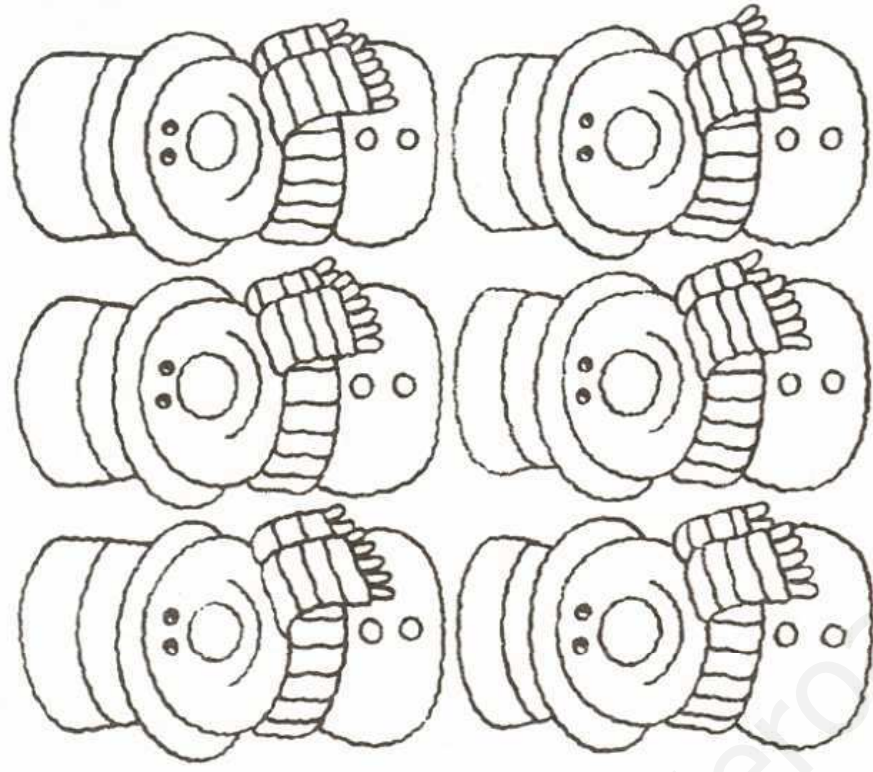
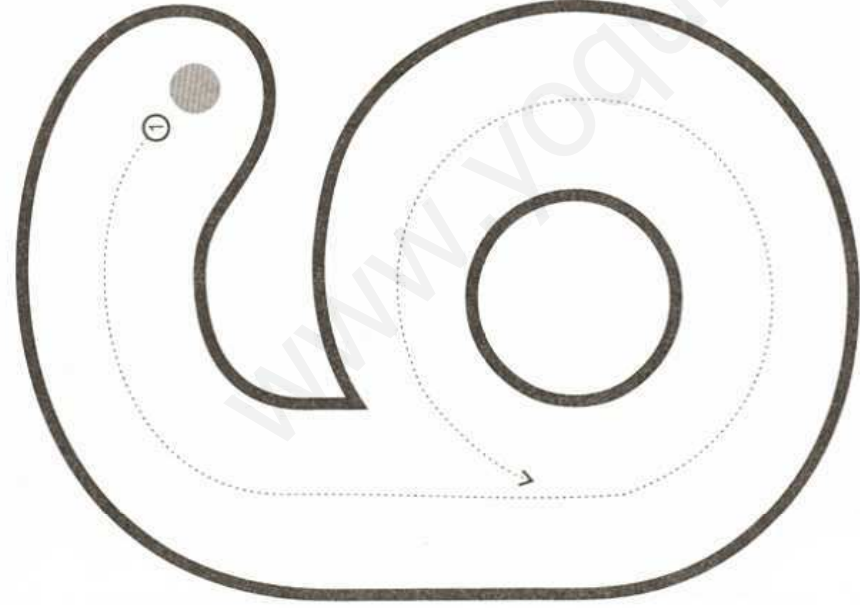

SEIS

- DELINEA Y COMPLETA CADA RENGLÓN.

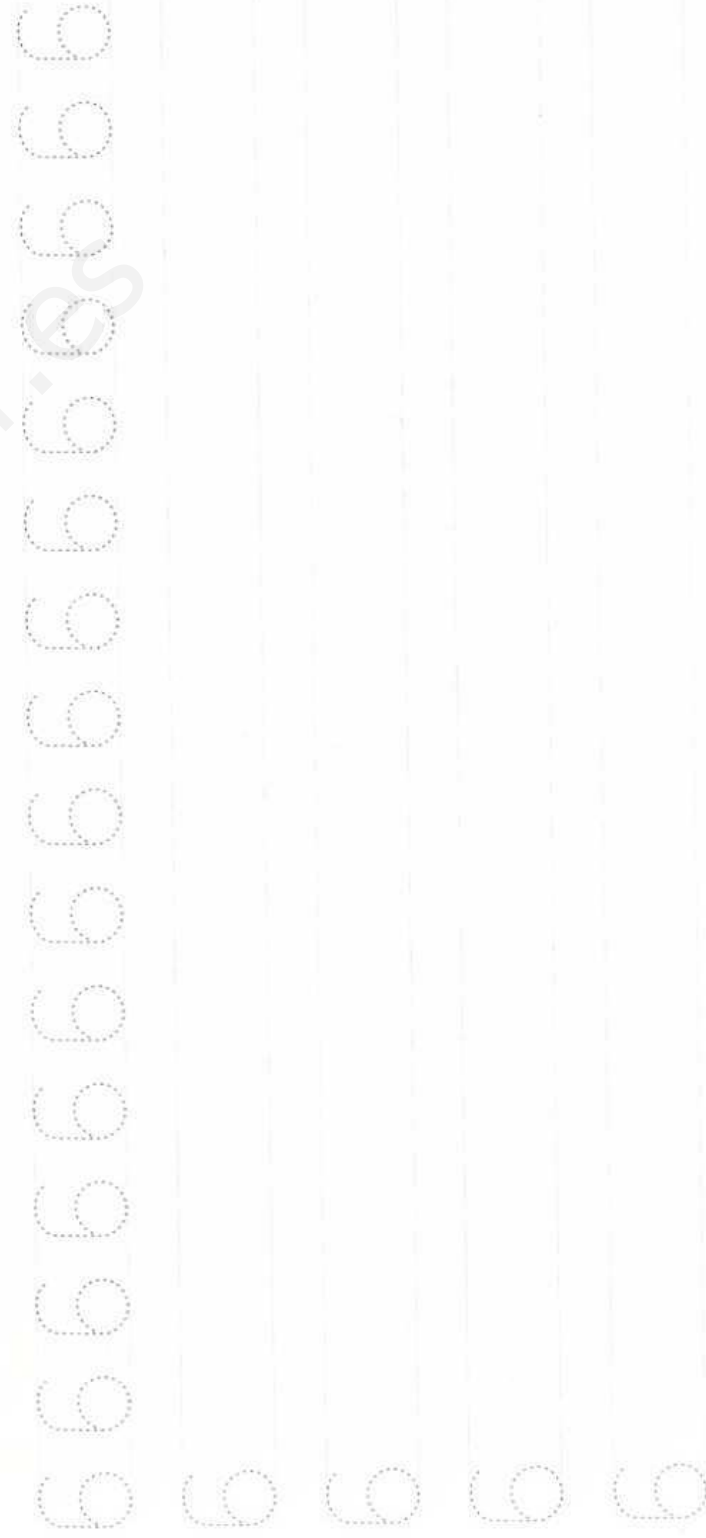

- COLOREA TANTOS CÍRCULOS COMO OBJETOS HAY EN CADA HILERA.
- ESCRIBE EL NÚMERO CORRESPONDIENTE EN EL CASILLERO.

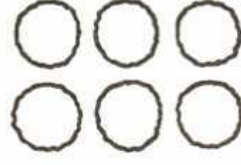
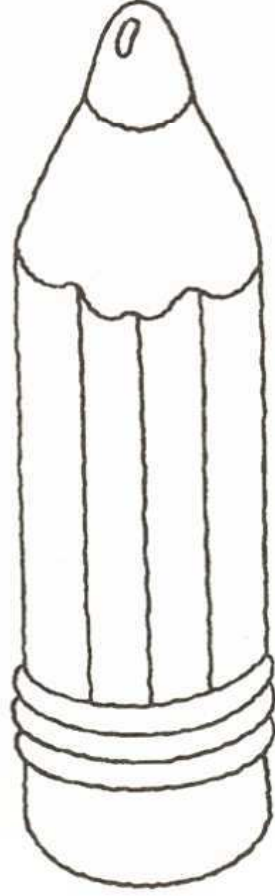
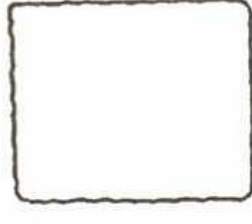
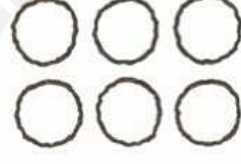
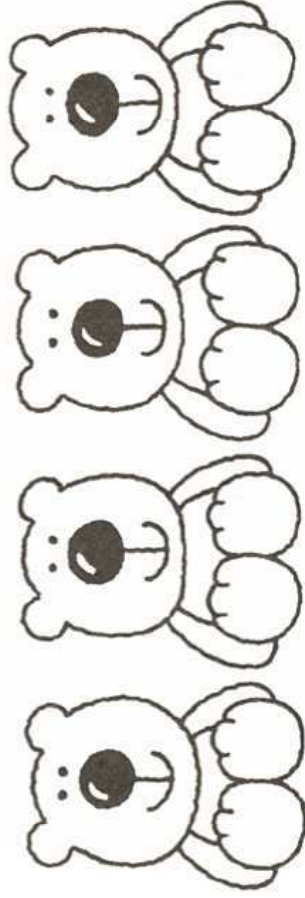
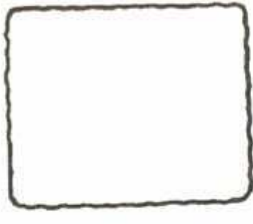
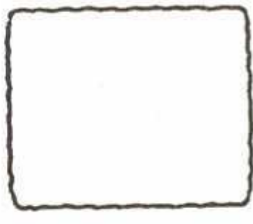
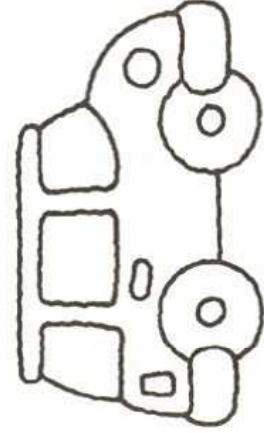
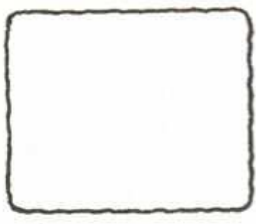
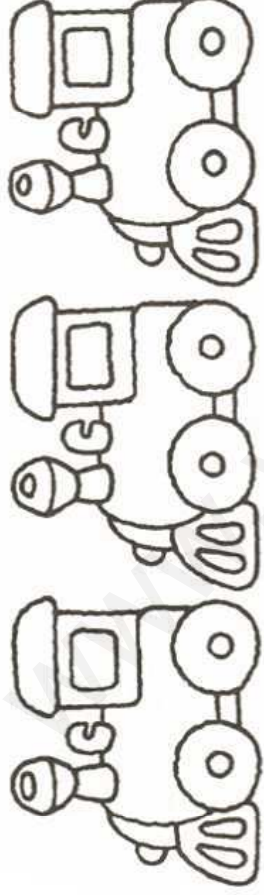
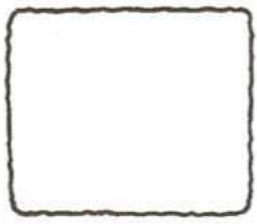
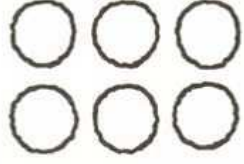
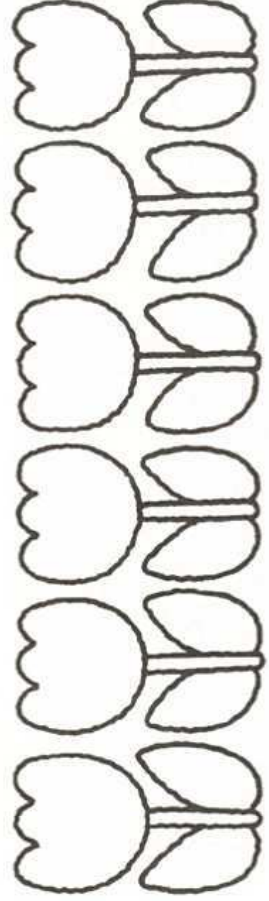

- RECORRE VARIAS VECES EL NÚMERO CON TU DEDO ÍNDICE.
- DECÓRALO CON PINTITAS DE COLORES.

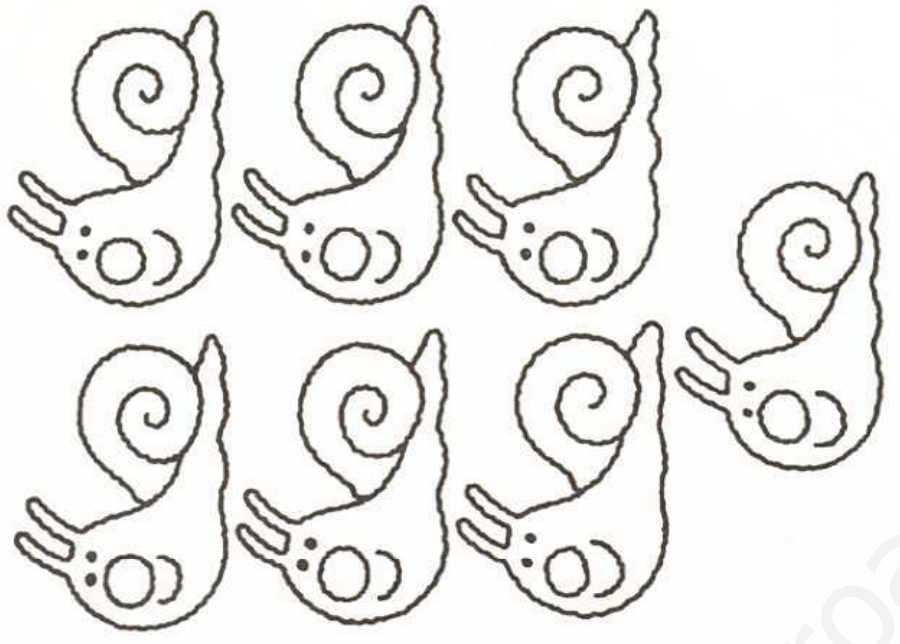
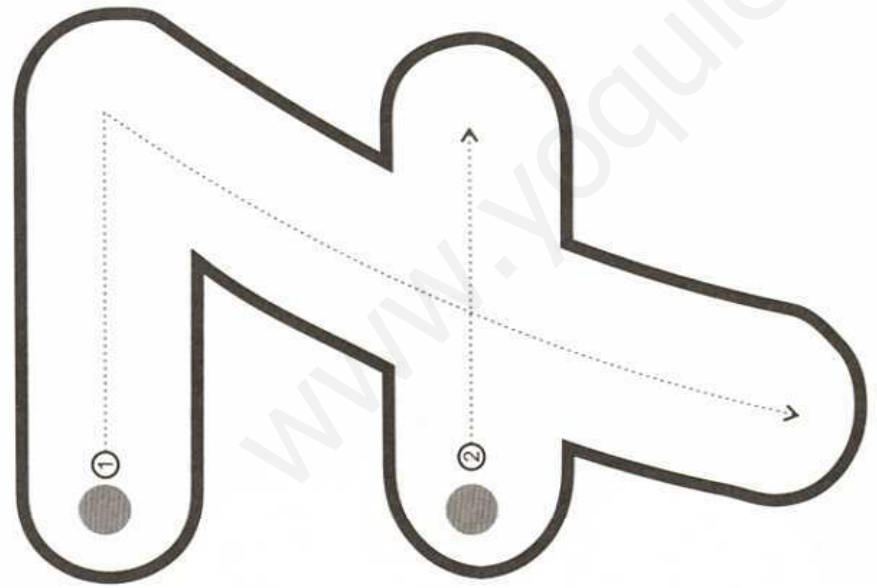

SIETE

- DELINEA Y COMPLETA CADA RENGLÓN.

Tracing practice area with four rows of horizontal lines. The first row contains ten dashed number 7s for tracing. The second row contains five dashed number 7s. The third row contains three dashed number 7s. The fourth row contains two dashed number 7s.

• COLOREA SEGÚN EL CÓDIGO DE COLORES.

20

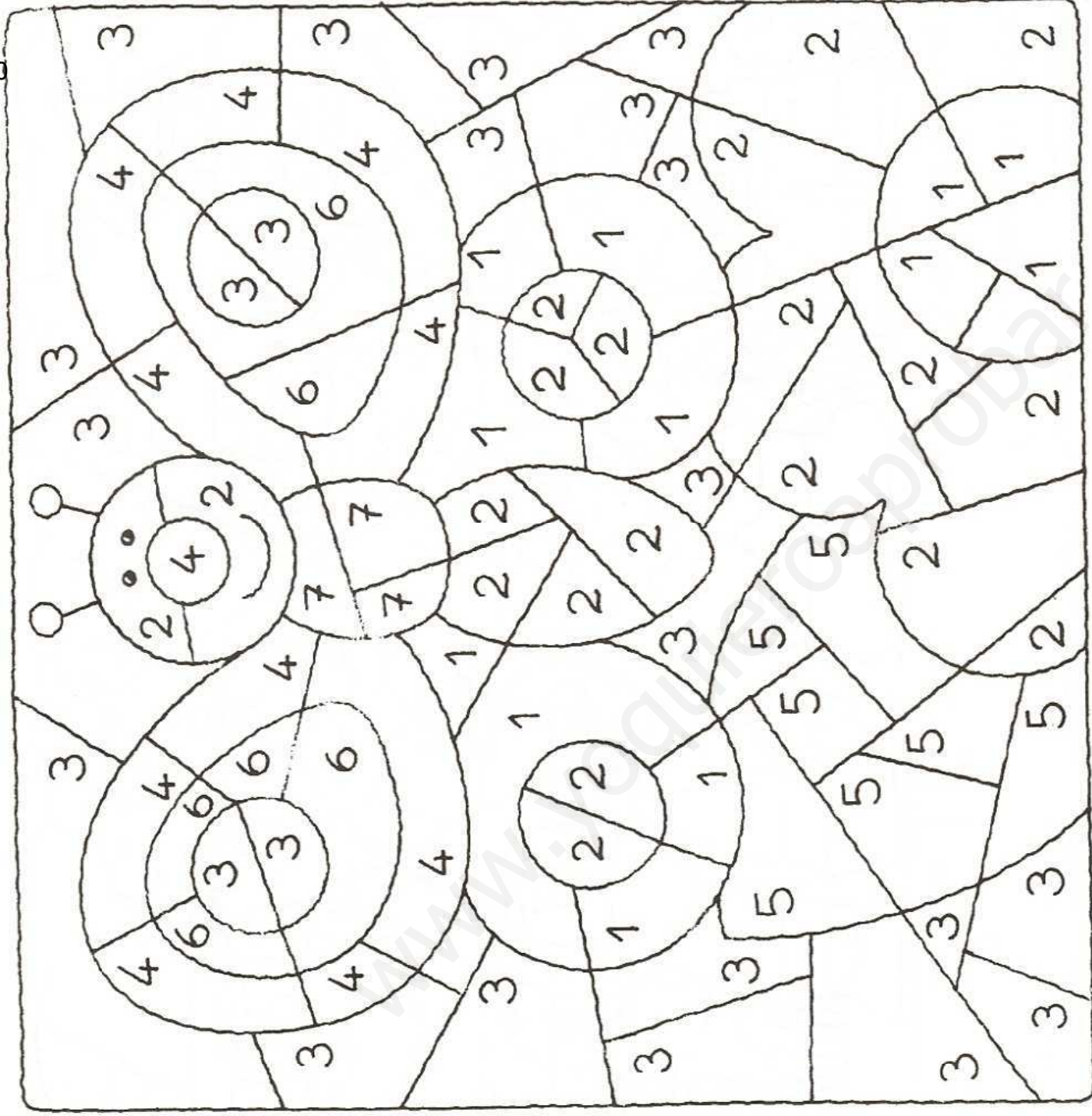

1

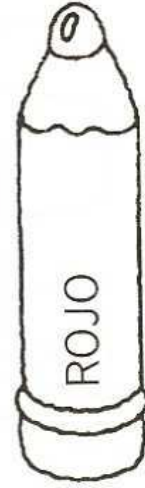

2



3



4

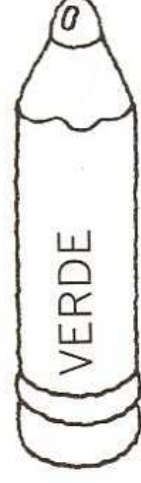

5

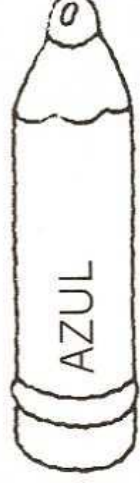

6



7

1

2

3

4

5

6

7

8

9

10

- RECORRE VARIAS VECES EL NÚMERO CON TU DEDO ÍNDICE.
- DECÓRALO COMO MÁS TE GUSTE.

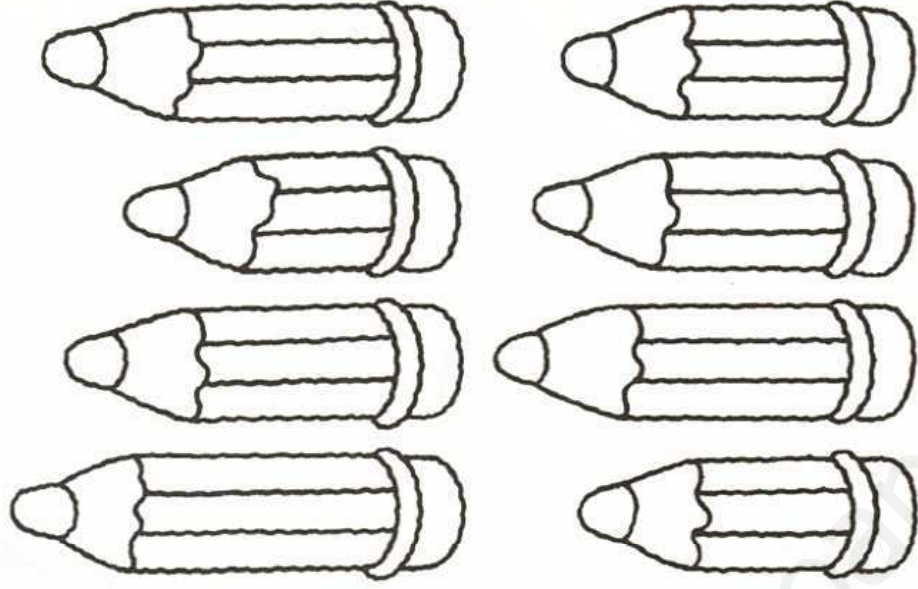
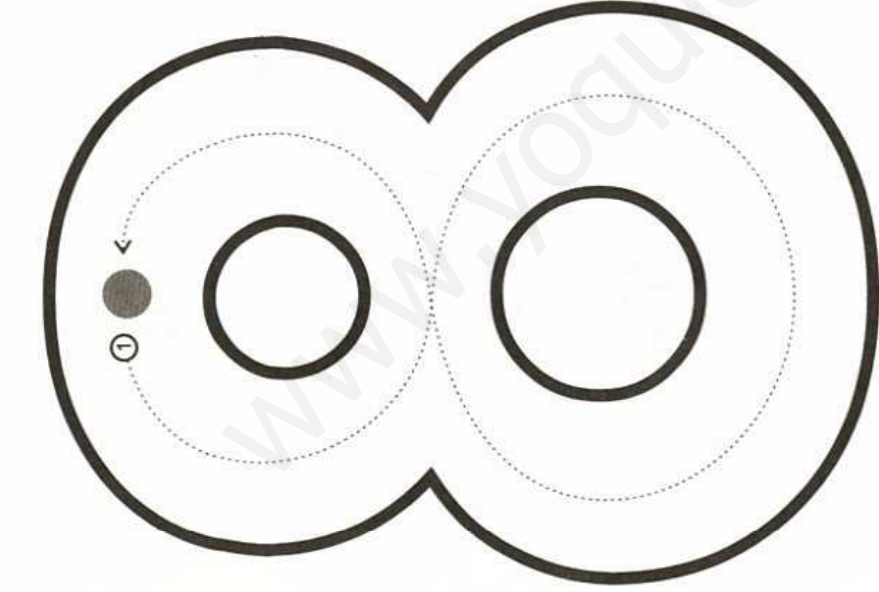

OCHO

- DELINEA Y COMPLETA CADA RENGLÓN.

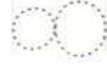
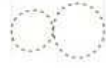

¡A BUSCAR!

• COLOREA Y CUENTA LOS DISTINTOS OBJETOS.

22

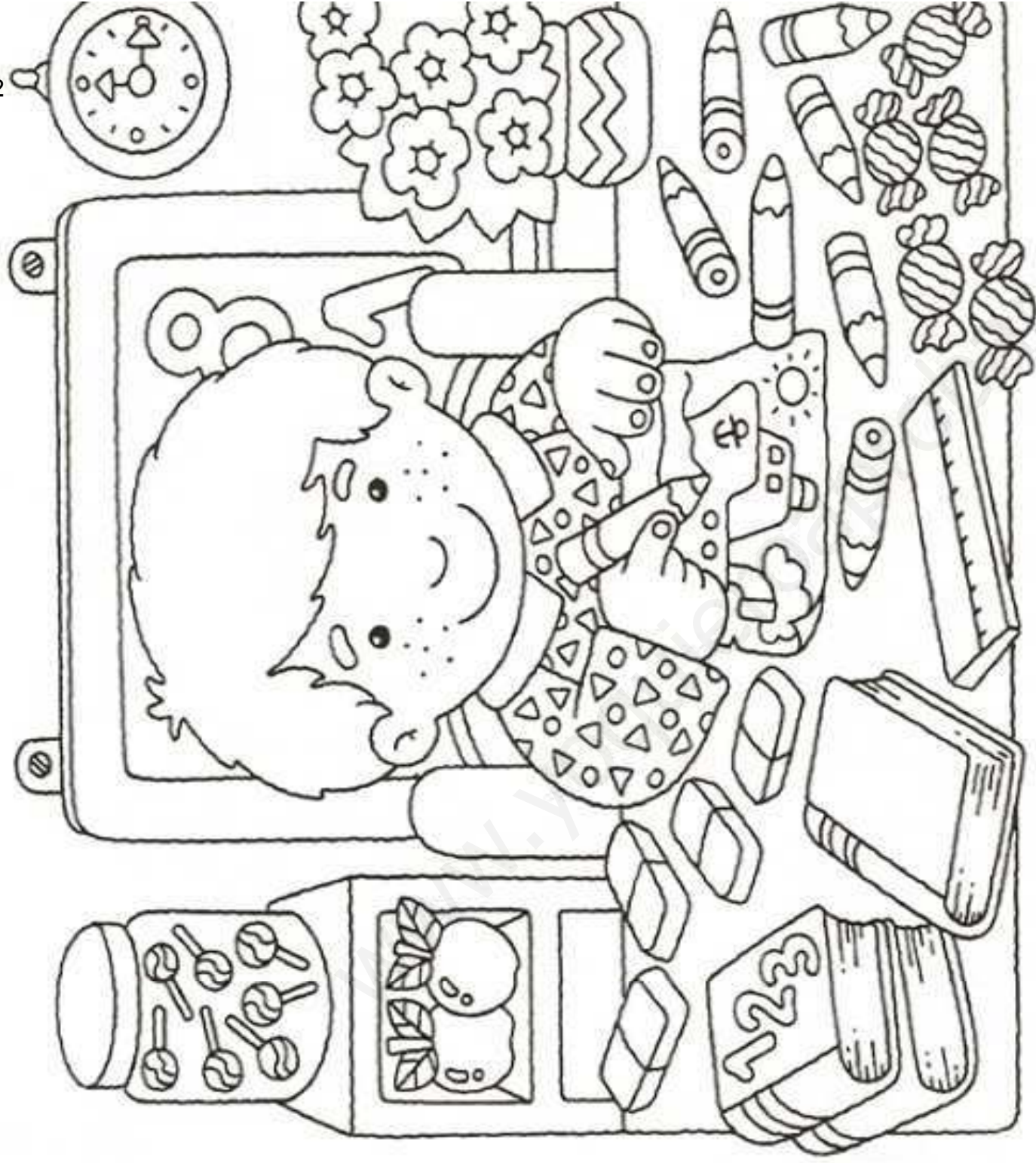

• ESCRIBE EL NÚMERO CORRESPONDIENTE EN CADA CASILLERO.

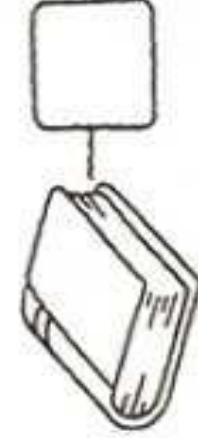
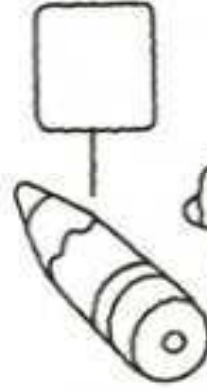

1

2

3

4

5

6

7

8

9

- RECORRE VARIAS VECES EL NÚMERO CON TU DEDO ÍNDICE.
- DECÓRALO CON CÍRCULOS DE VARIOS COLORES.

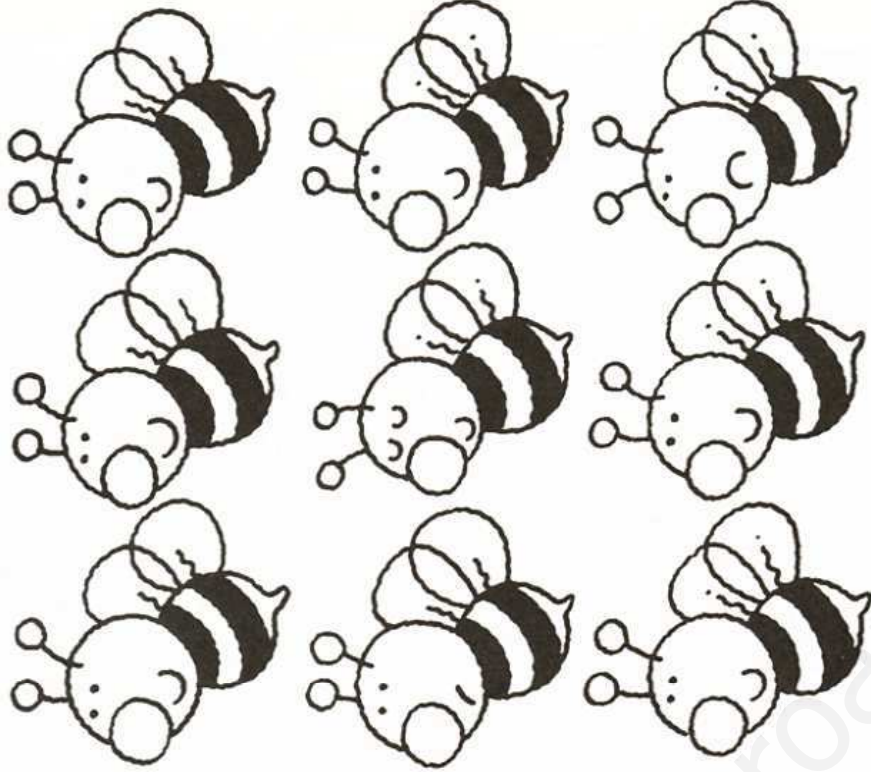
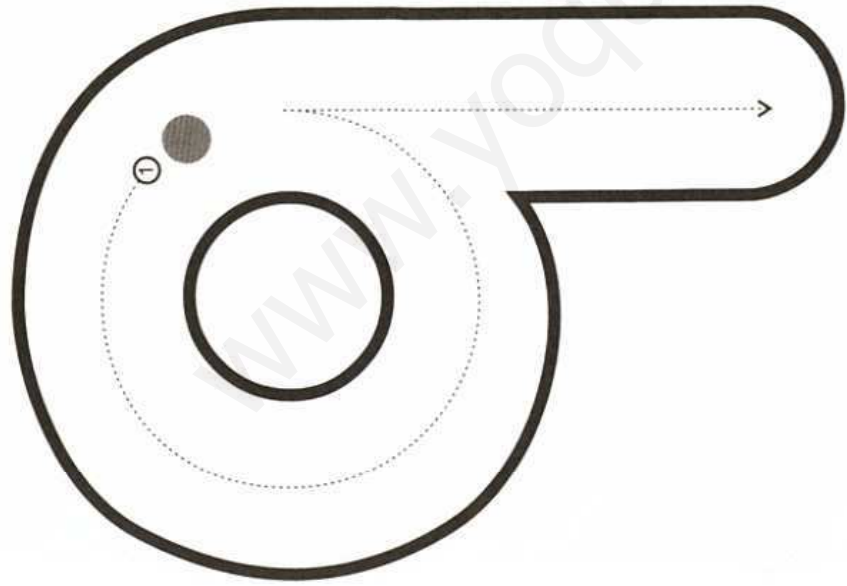

NUEVE

- DELINEA Y COMPLETA CADA RENGLÓN.

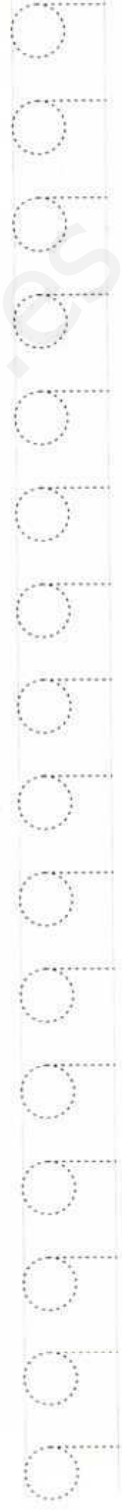

¡AYUDA AL JARDINERO A CONTAR!

- OBSERVA, COLOREA, CUENTA Y ESCRIBE EL NÚMERO EN EL CASILLERO CORRESPONDIENTE.

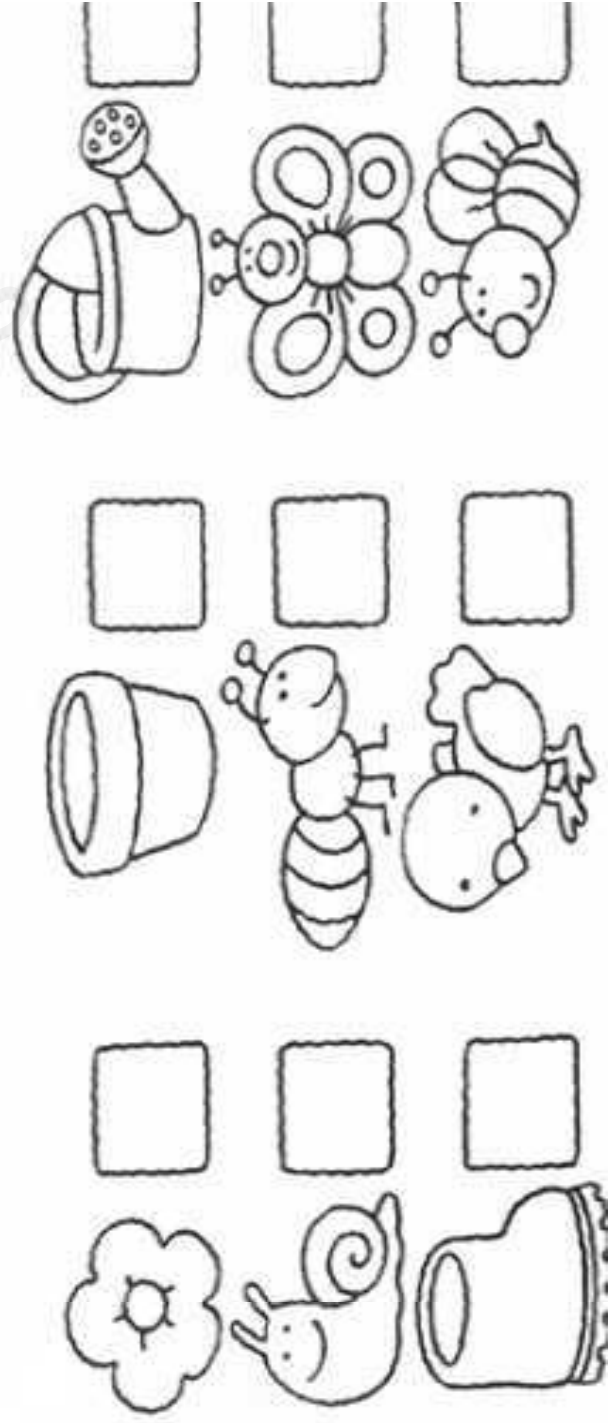
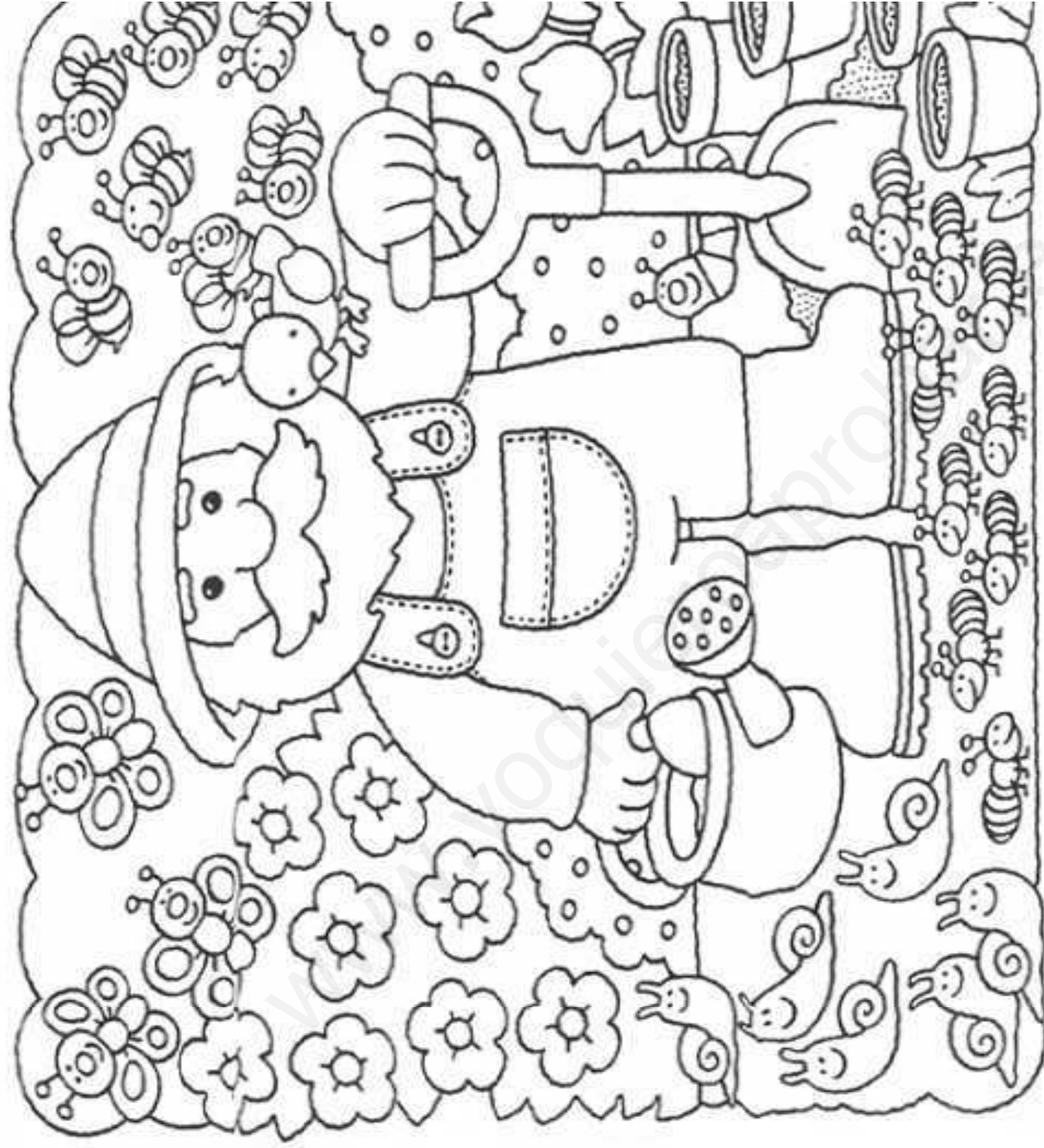



- RECORRE VARIAS VECES EL NÚMERO CON TU DEDO ÍNDICE.
- DECÓRALO COMO MÁS TE GUSTE.

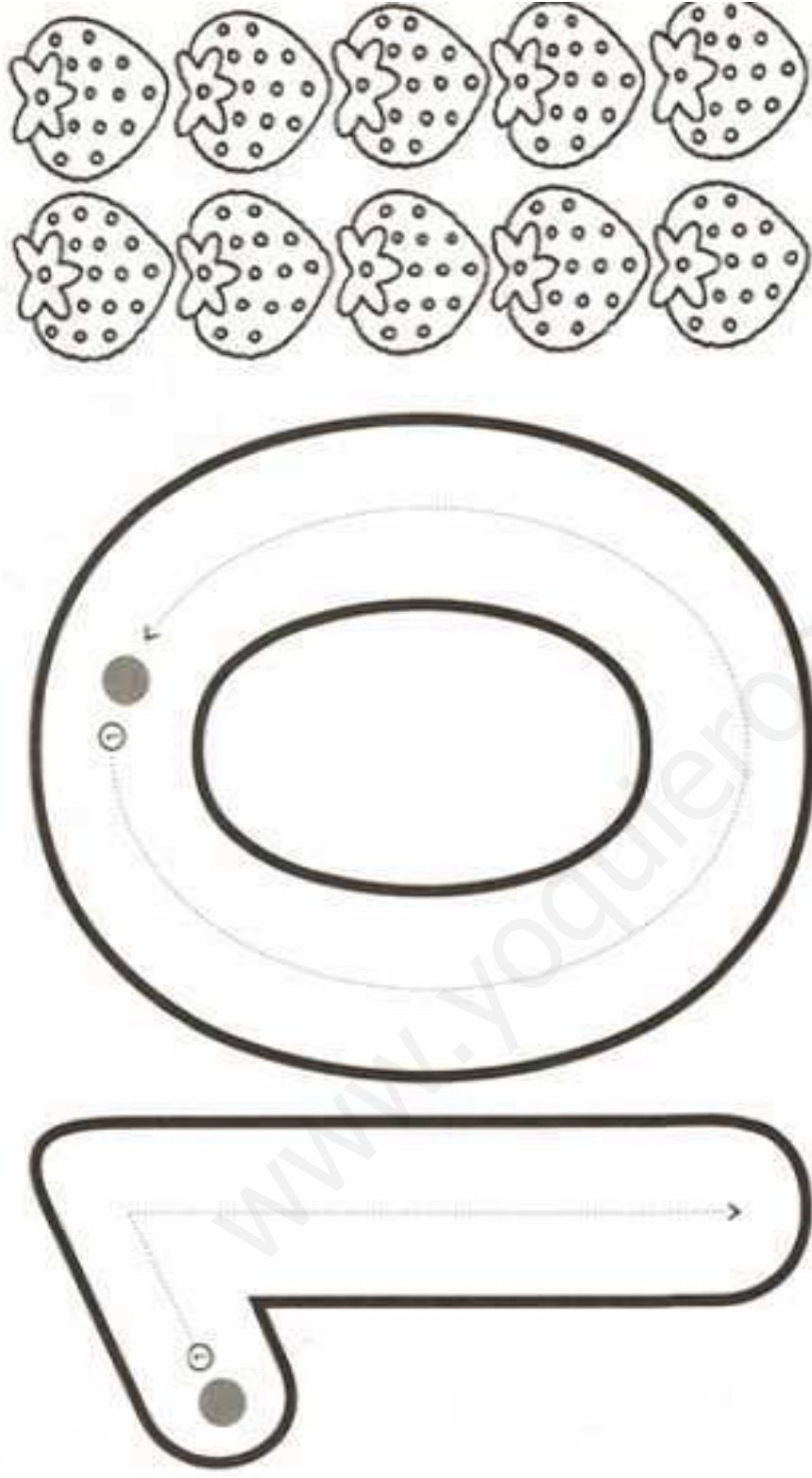

DIEZ

- DELINEA Y COMPLETA CADA RENGLÓN.



COMPLETA EL DIBUJO UNIENDO LOS PUNTOS DEL 1 AL 10.

¿CUÁNTAS ESTRELLAS HAY?

¿CUÁNTOS PECES HAY?

26

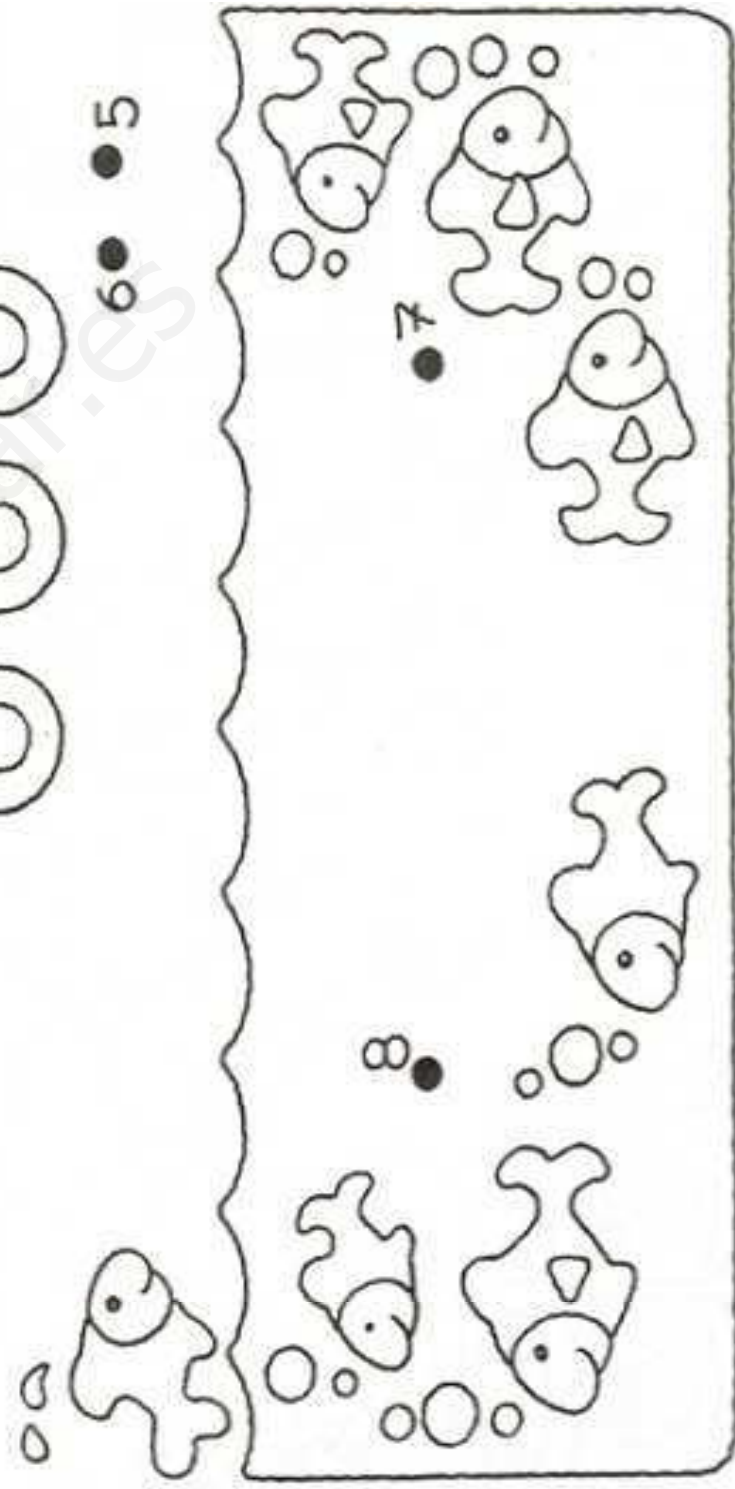
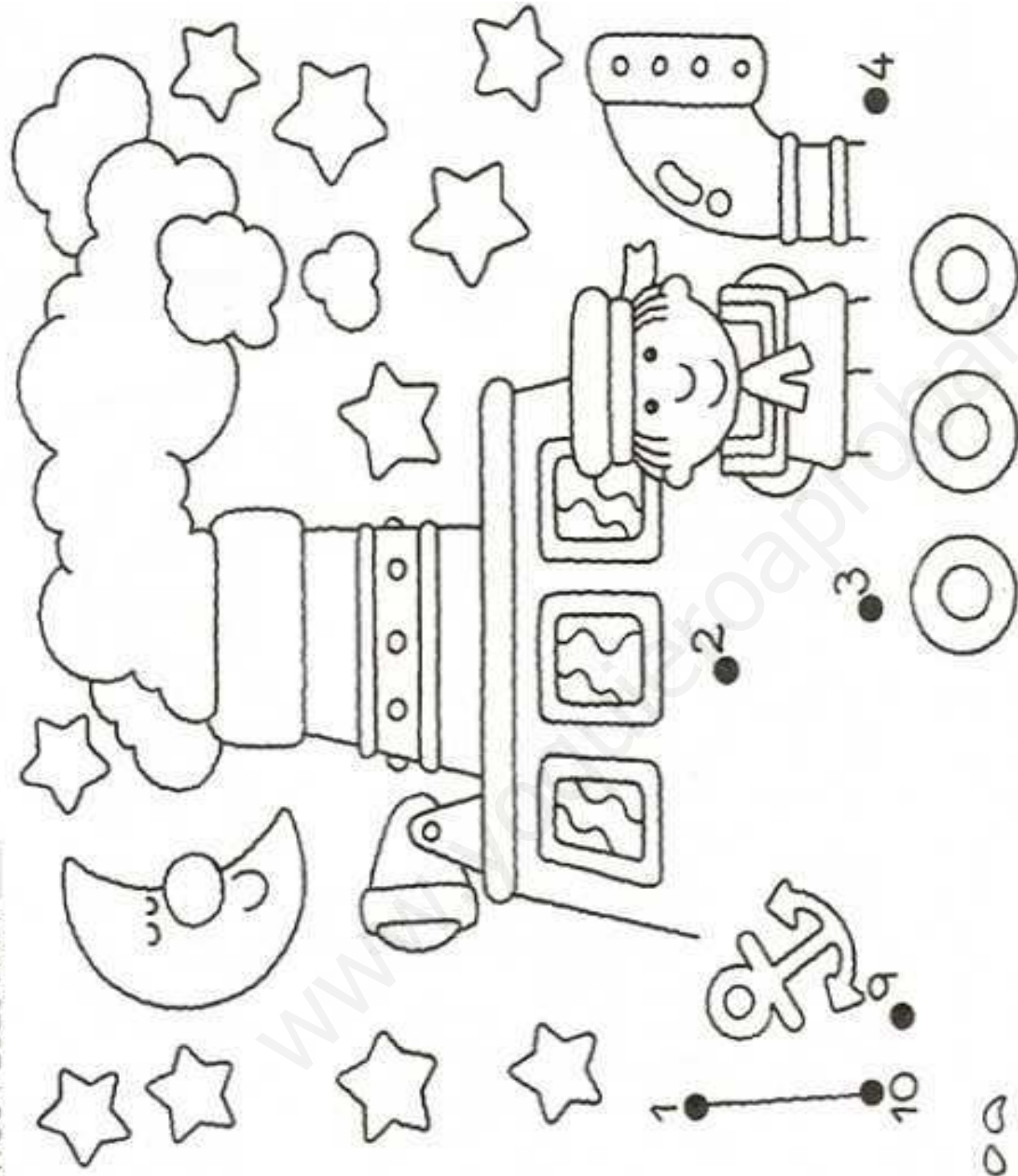

COMPLETA EL DIBUJO UNIENDO LOS PUNTOS DEL 1 AL 10.

¿CUÁNTAS ESTRELLAS HAY?

¿CUÁNTOS PECES HAY?

27

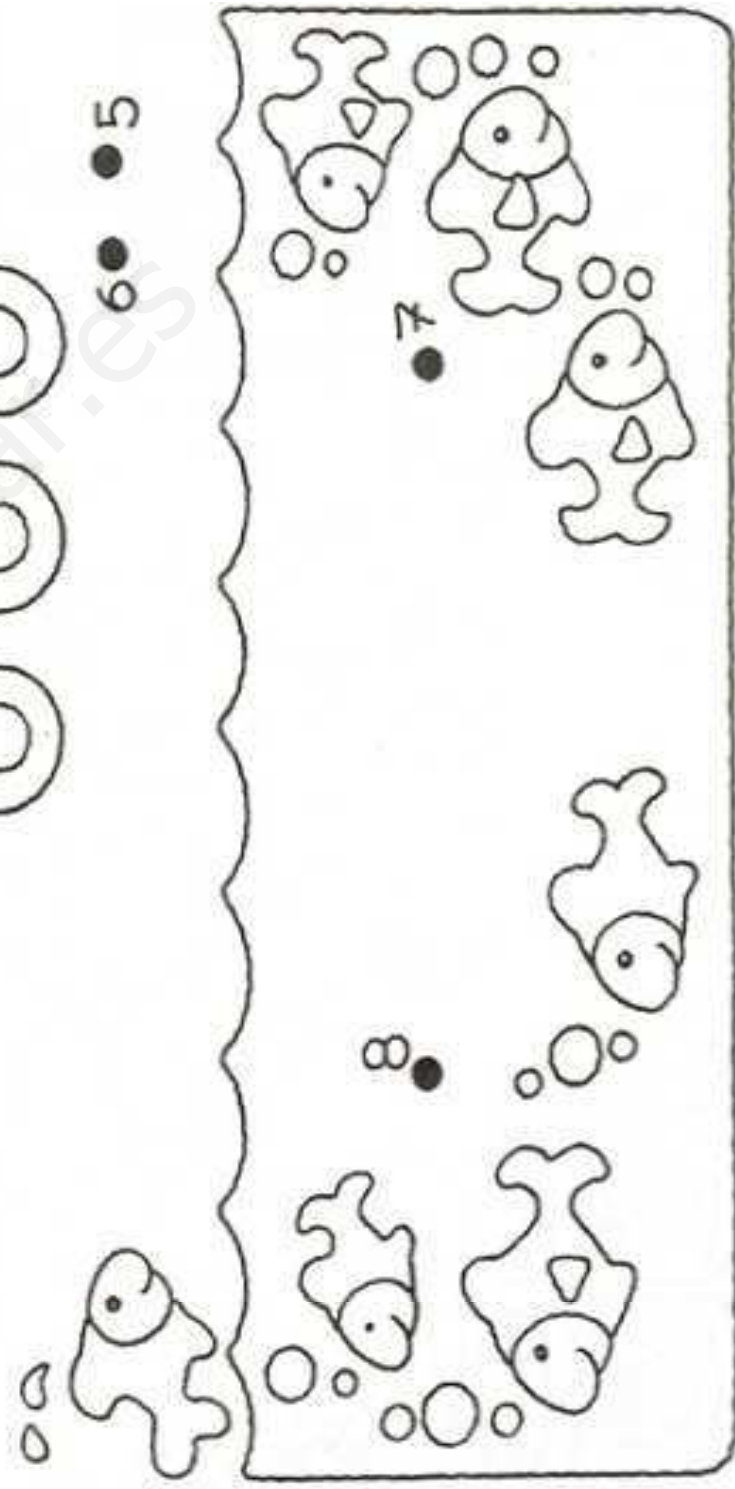
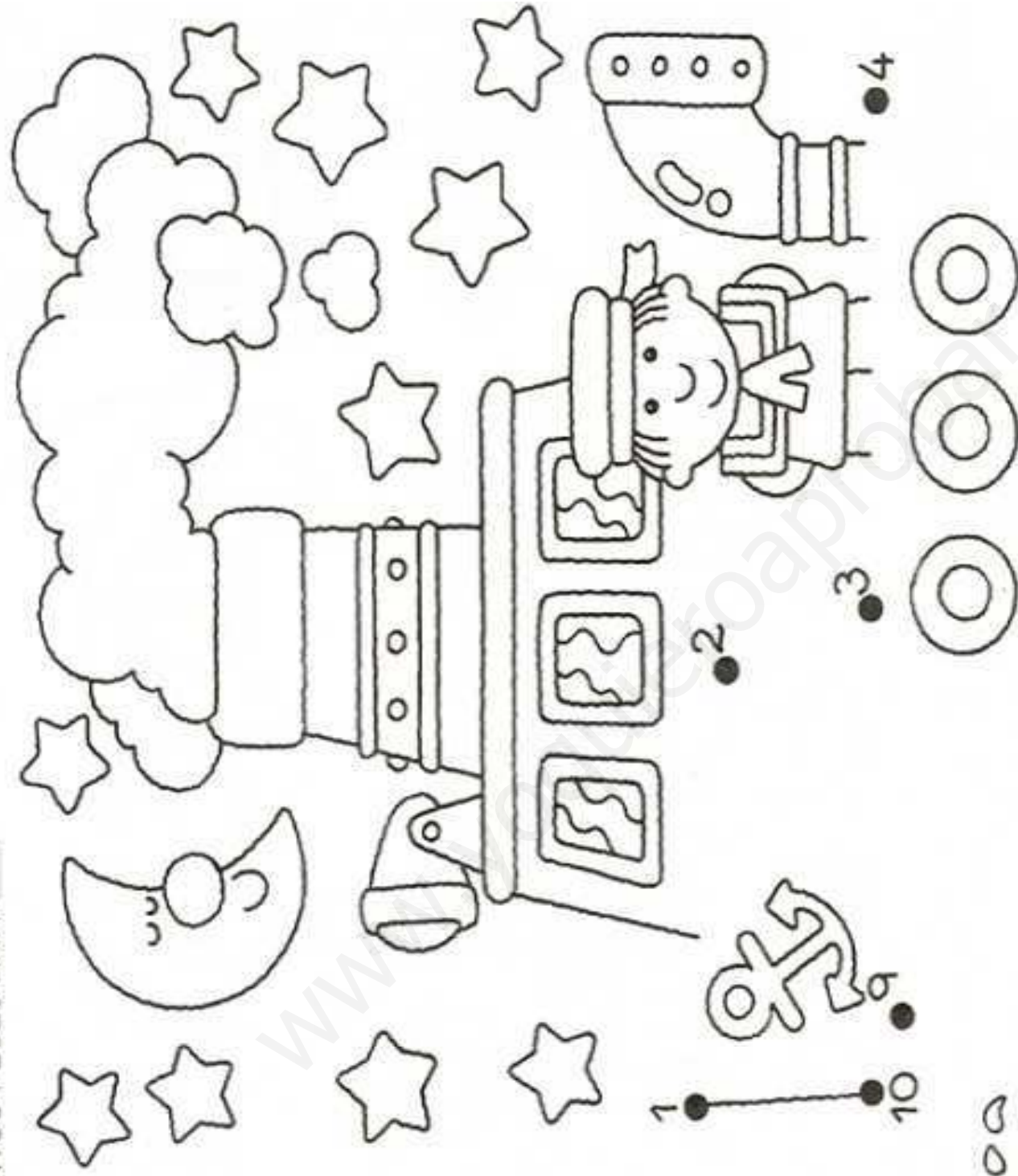

• COLOREA LOS NÚMEROS DE CADA CUEVA Y LOS PECES.

• INDICA CON COLOR EL CAMINO DE CADA GRUPO DE PECES HACIA SU GUARIDA CORRESPONDIENTE.

28

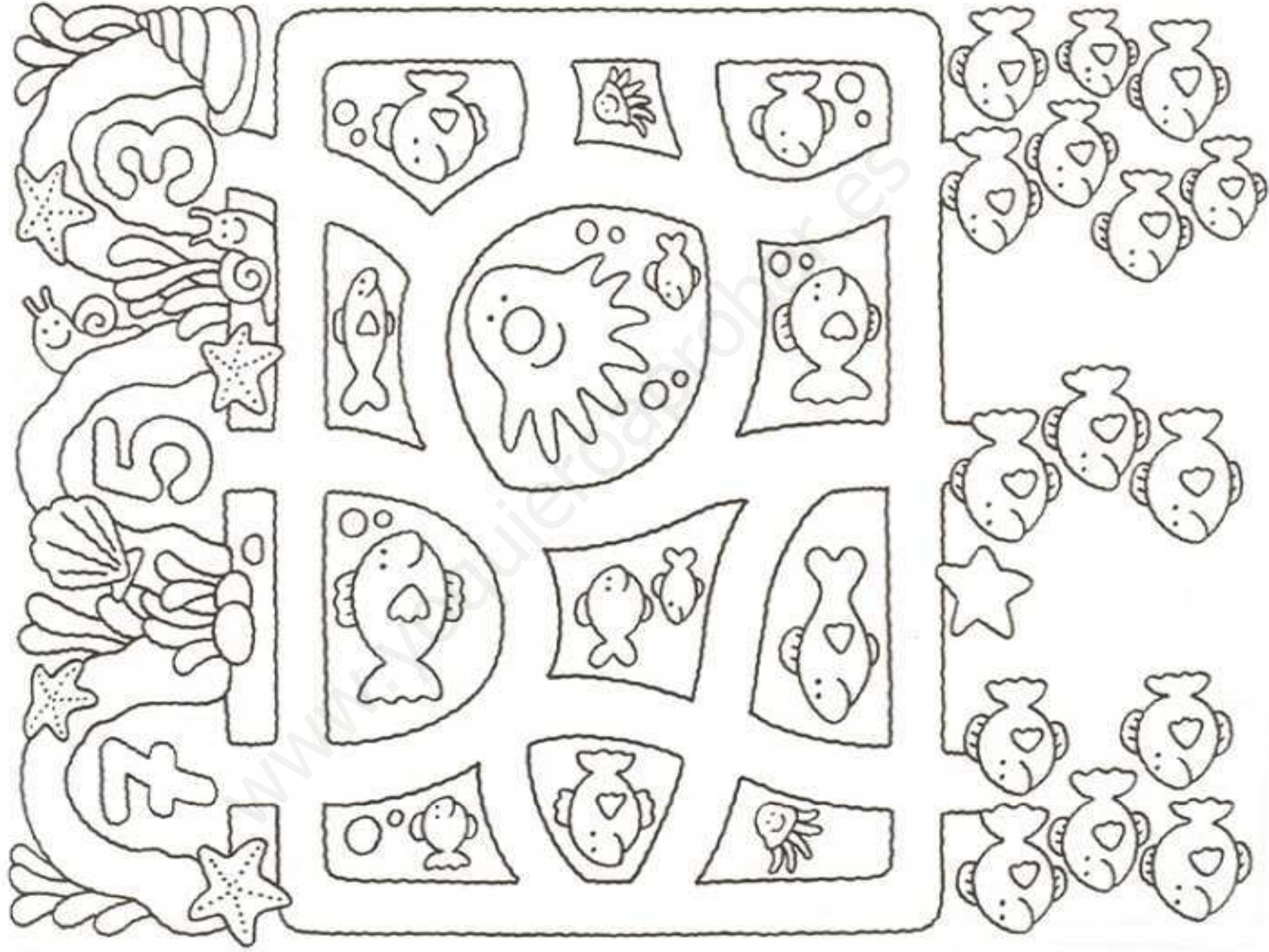

¿CUÁL ES EL COLLAR QUE ENHEBRÓ CADA UNO?

- UTILIZA TRES COLORES DIFERENTES PARA NUMERAR Y DELINEAR CADA COLLAR.
- COLOREA LAS CUENTAS QUE NO PERTENECEN A NINGÚN COLLAR.

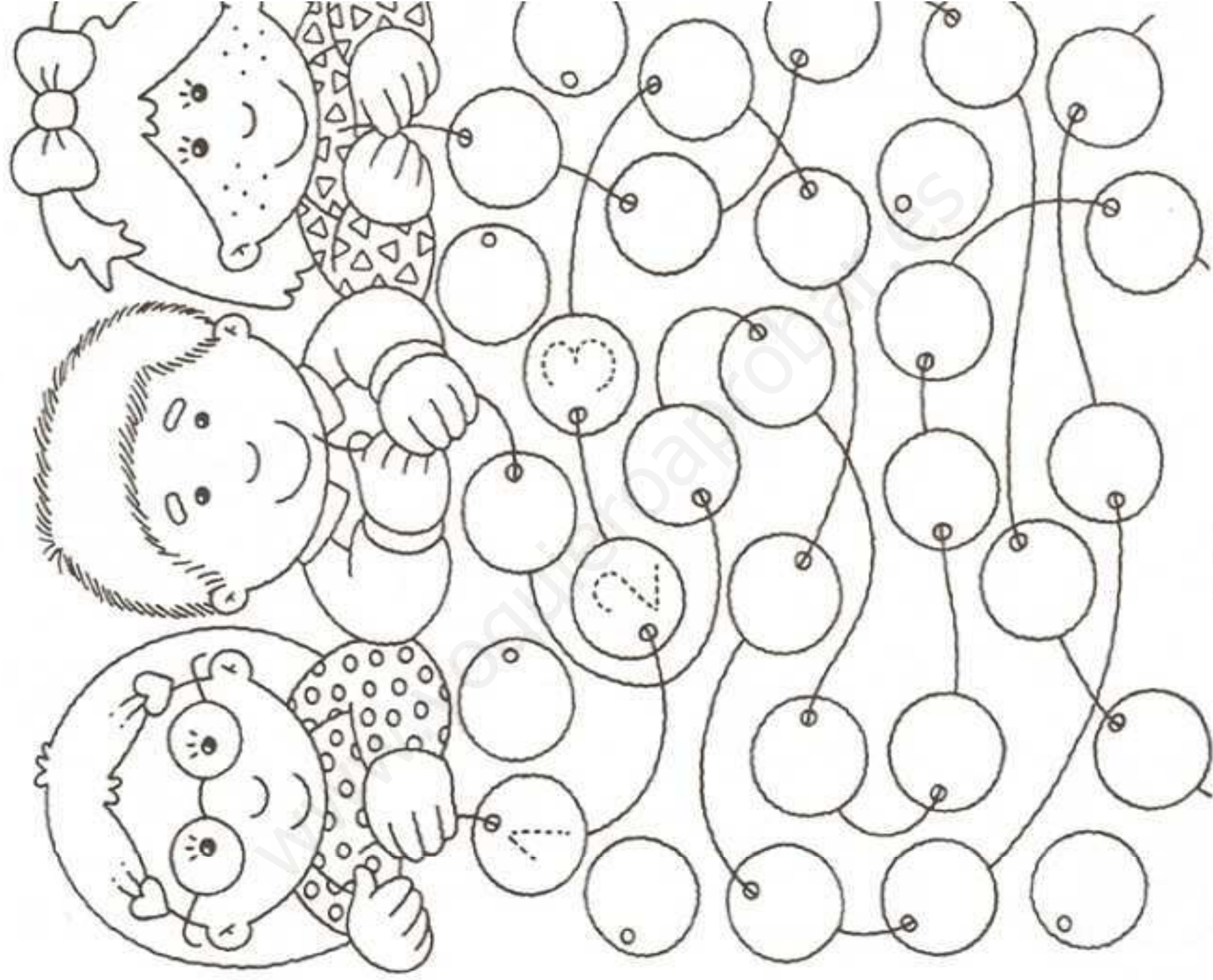

• EL COLLAR MÁS LARGO TIENE

• EL COLLAR MÁS CORTO TIENE

• DELINEA Y COMPLETA CADA VIBORITA CON LOS NÚMEROS DEL 1 AL 10.

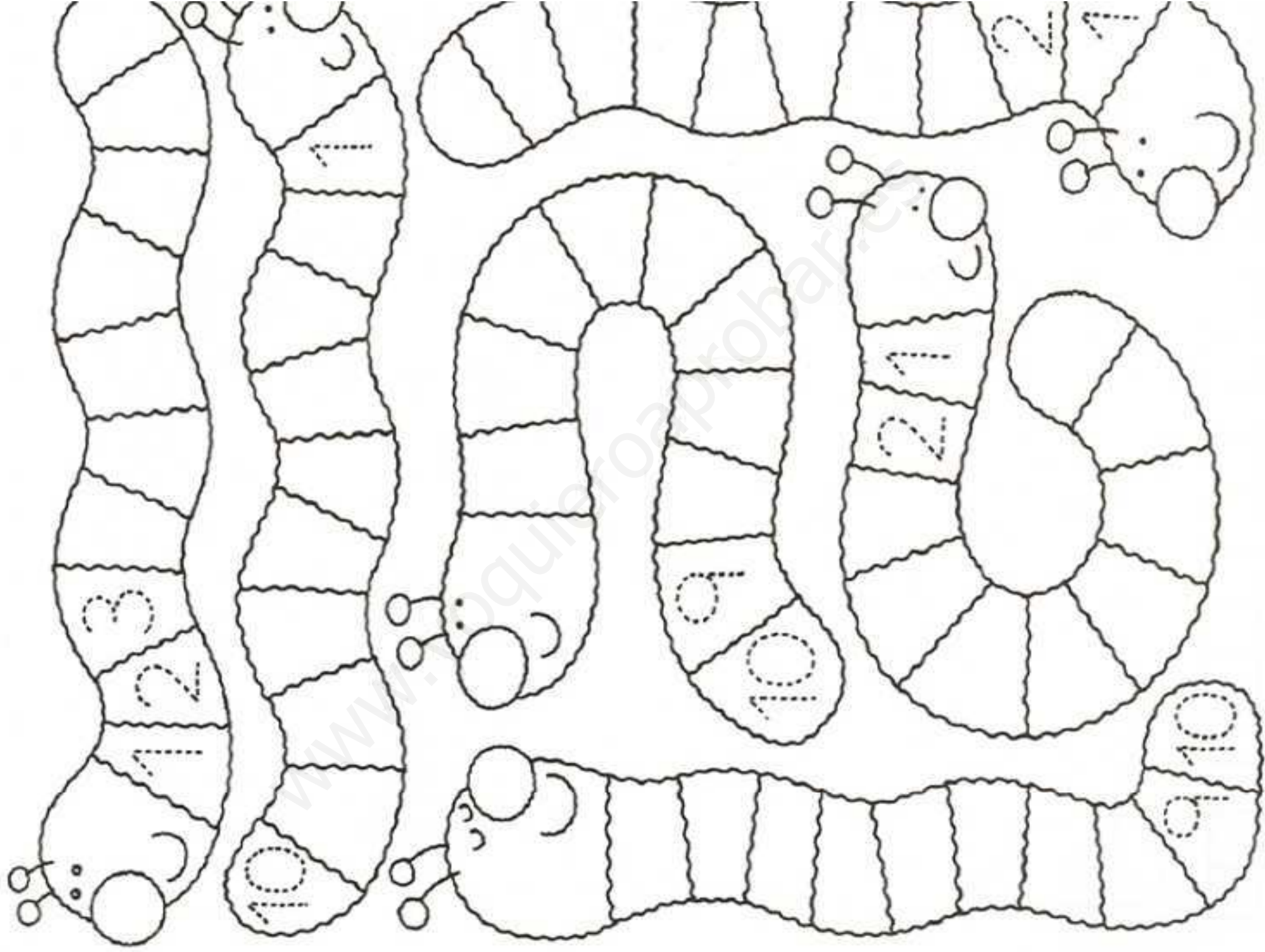

• DELINEA LOS NÚMEROS DE CADA CAMISETA...

• SEÑALA CON UNA LÍNEA EL RECORRIDO DE LA PELOTA DEL JUGADOR 1 AL 10.

• RODEA CON UNA LÍNEA EL JUGADOR QUE **NO** RECIBE LA PELOTA.

• COLOREA LAS CAMISETAS COMO MÁS TE GUSTE.

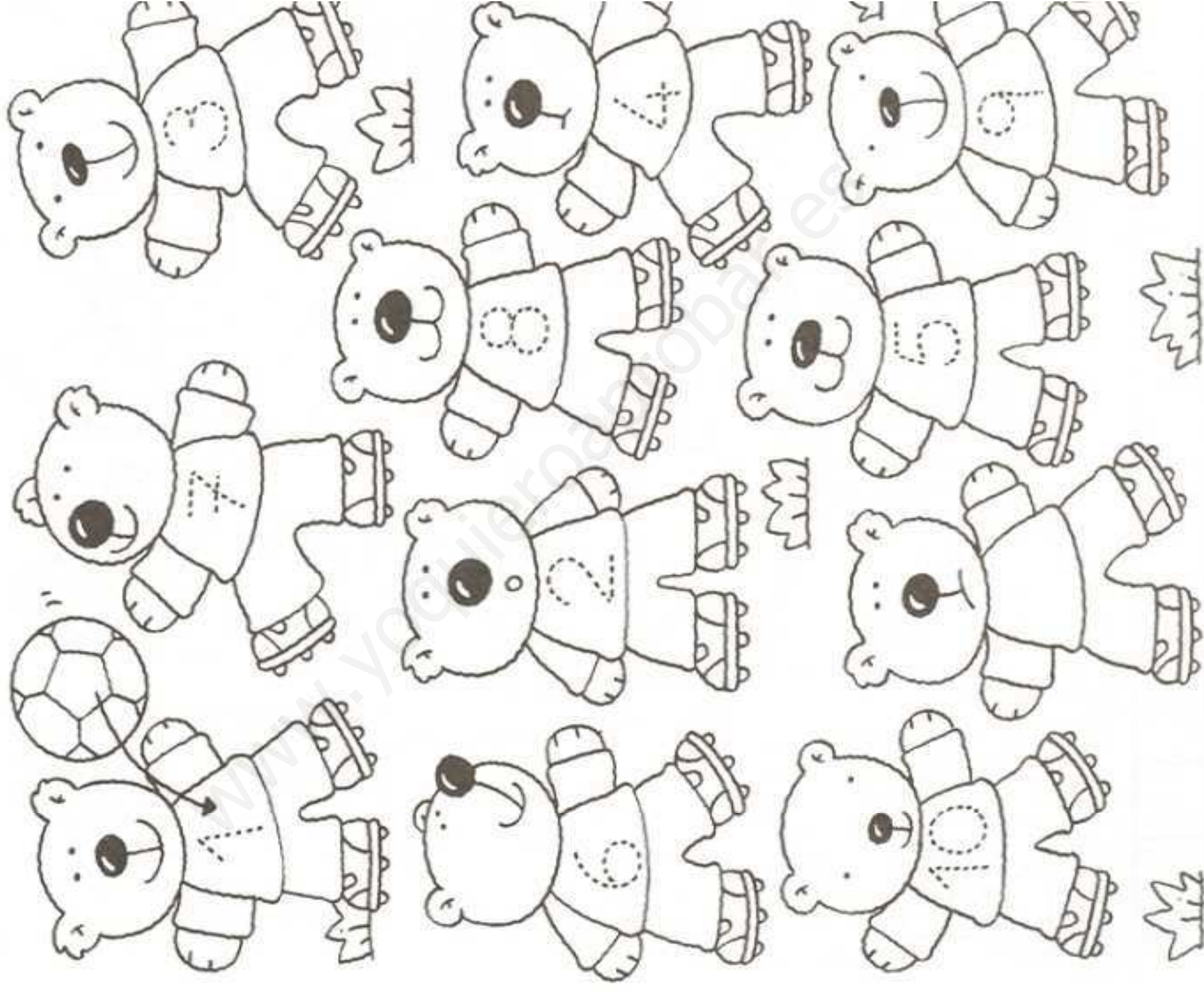

¿PARA CUÁNTAS COSAS USAMOS LOS NÚMEROS?

NOMBRA EN VOZ ALTA CADA OBJETO. ¿DE QUÉ SIRVEN LOS NÚMEROS EN ESOS

34

OBJETOS?

ANÍMATE A ESCRIBIR LOS NÚMEROS EN CADA UNO DE ELLOS.

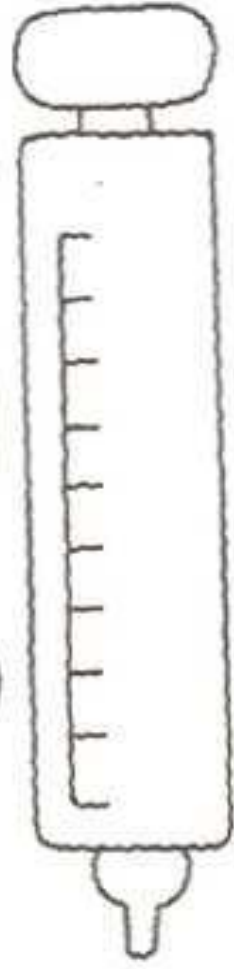
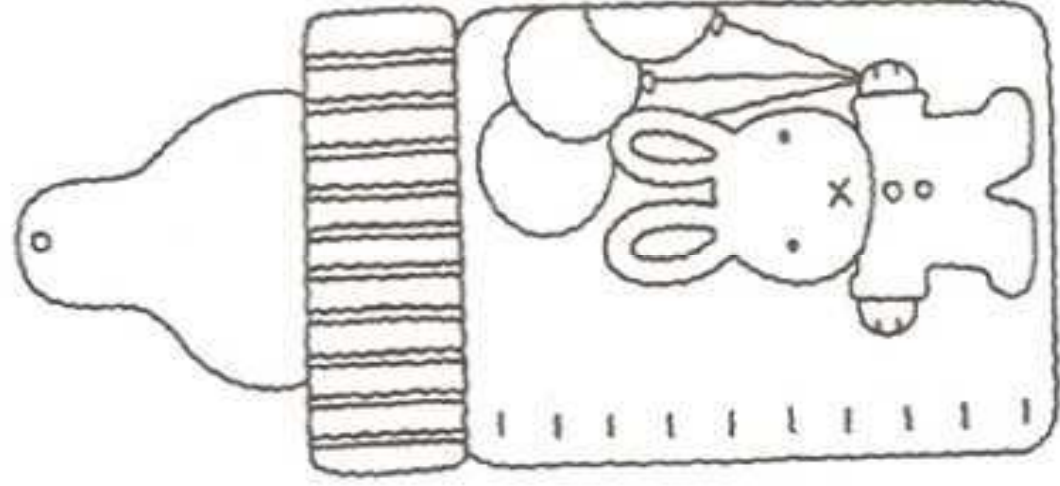
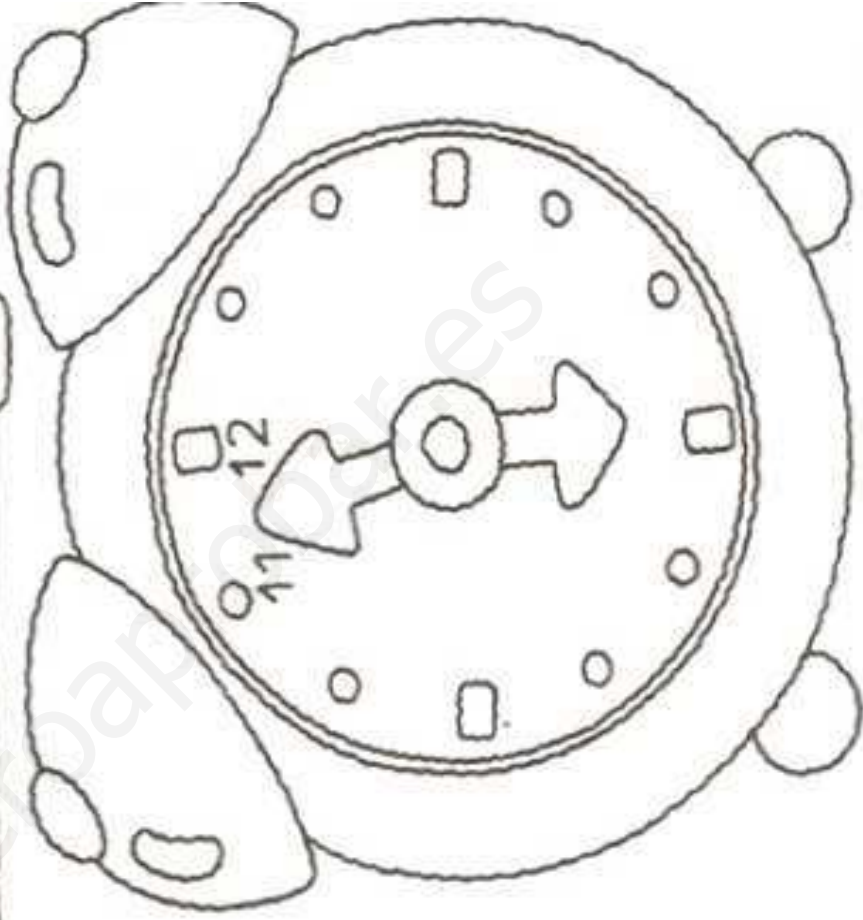
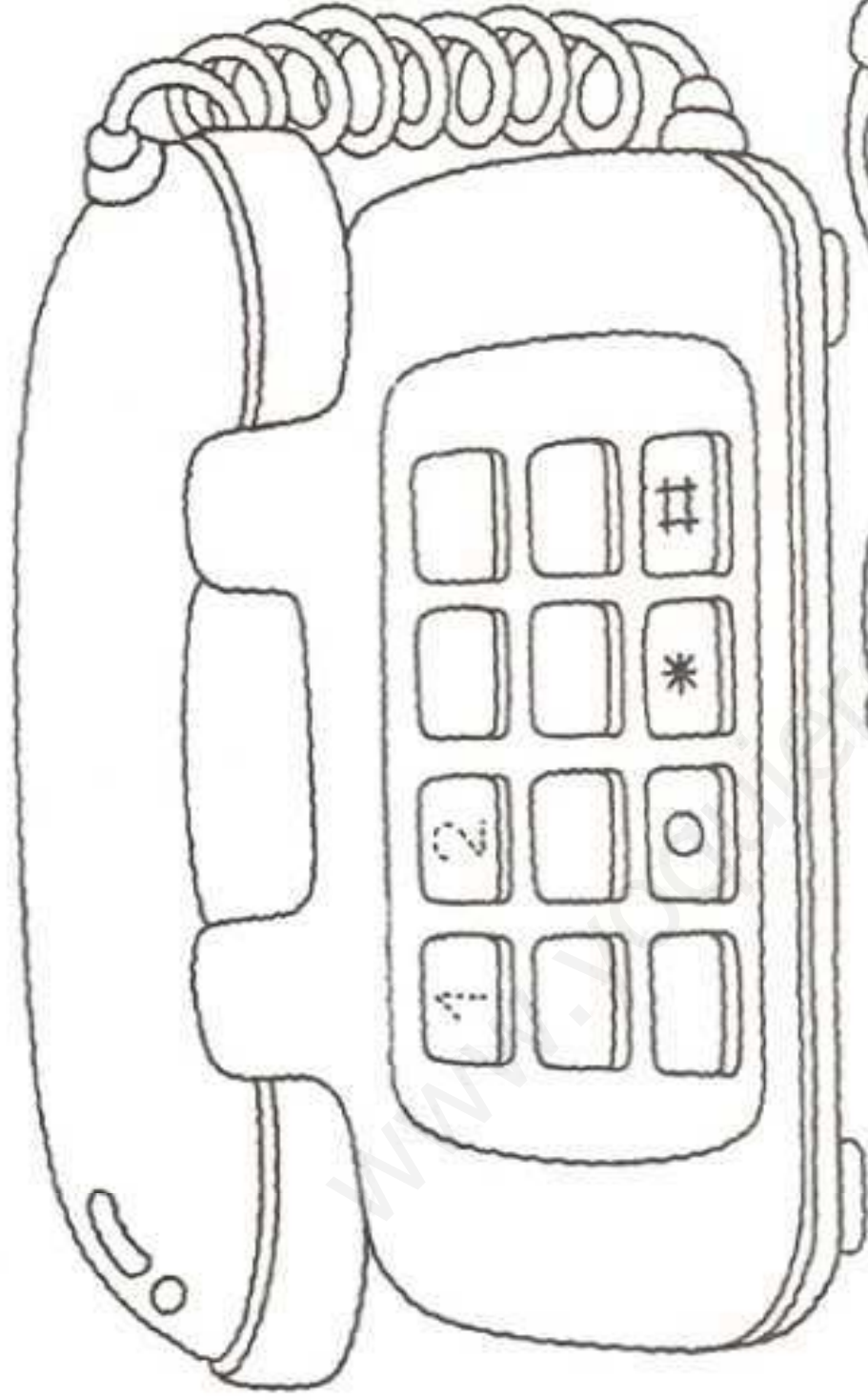

• AYUDA AL VERDULERO A ESCRIBIR LOS PRECIOS EN CADA CARTELITO.

• ¿CUÁL TE PARECE MÁS BARATO?

• ¿Y EL MÁS CARO?

• ¿CUÁNTAS MARIQUITAS ESCONDIDAS HAY?

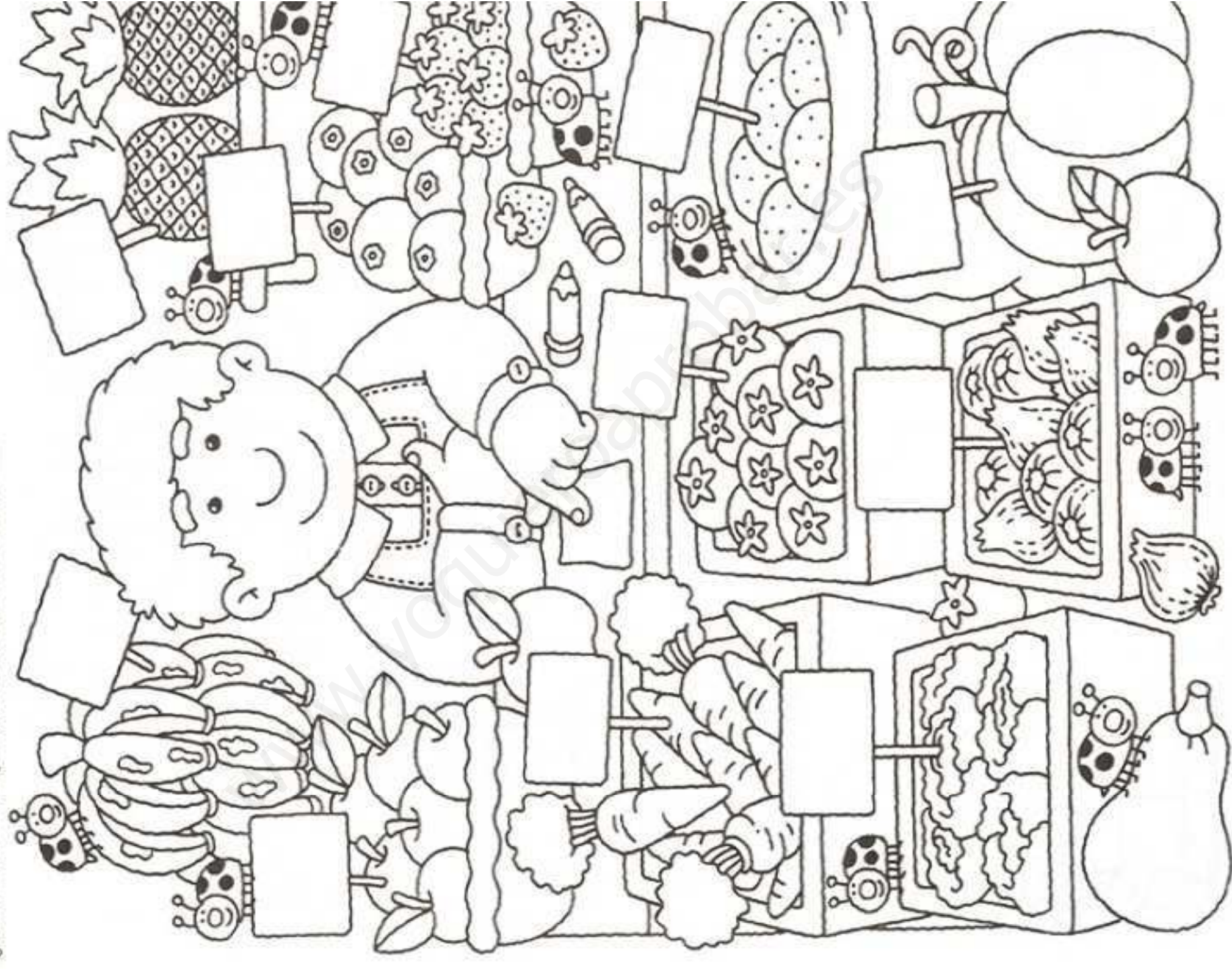

ENCUENTRA EN ESTA CASA Y DESCUBRE TODOS LOS NÚMEROS ESCONDIDOS. COLOREA LO QUE PUEDES DECIR EL NOMBRE DE CADA UNO DE ELLOS?

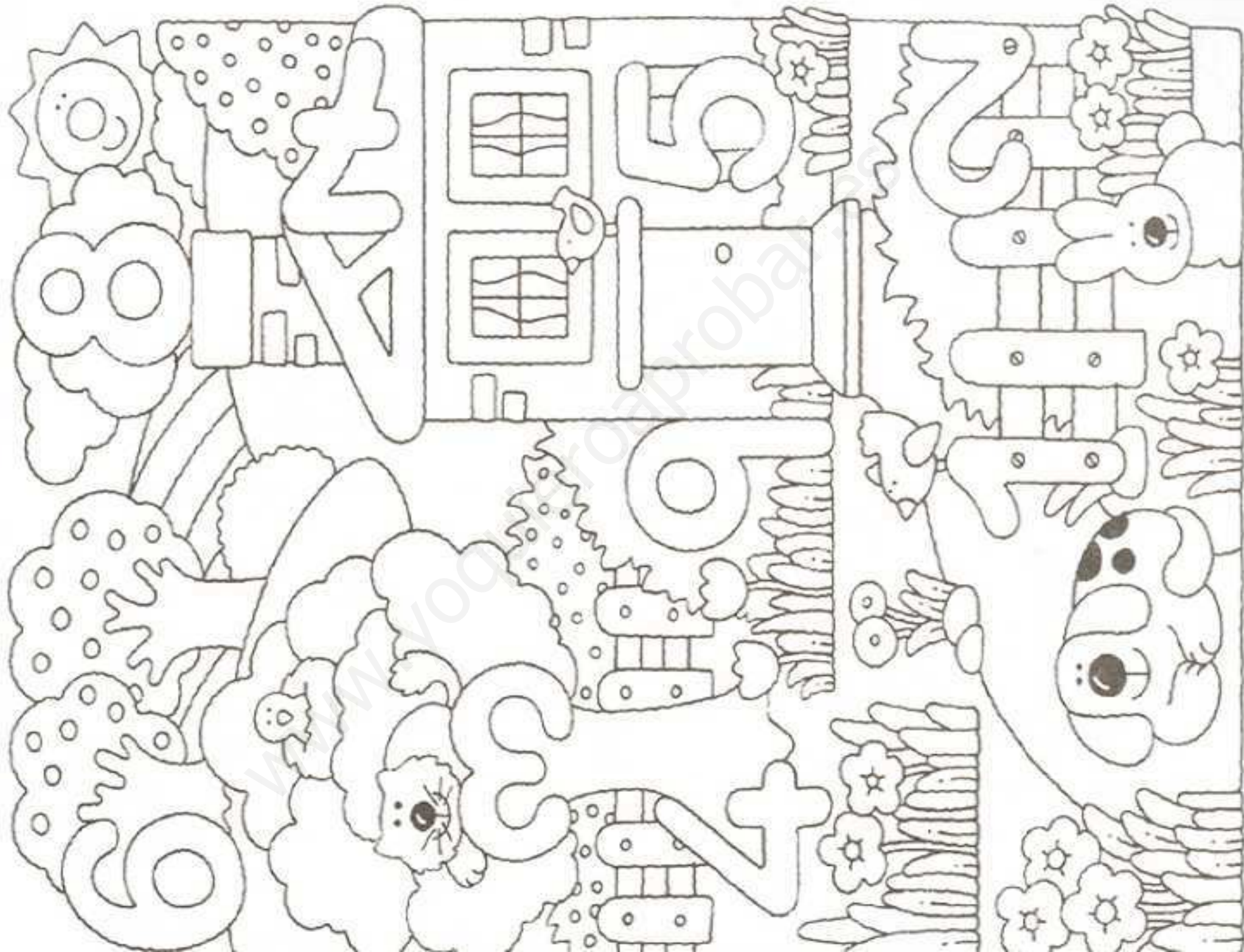

- RECORTA NÚMEROS DE UNA REVISTA Y PÉGALOS DENTRO DEL GLOBO GIGANTE.
- COLOREA LOS ENANITOS.

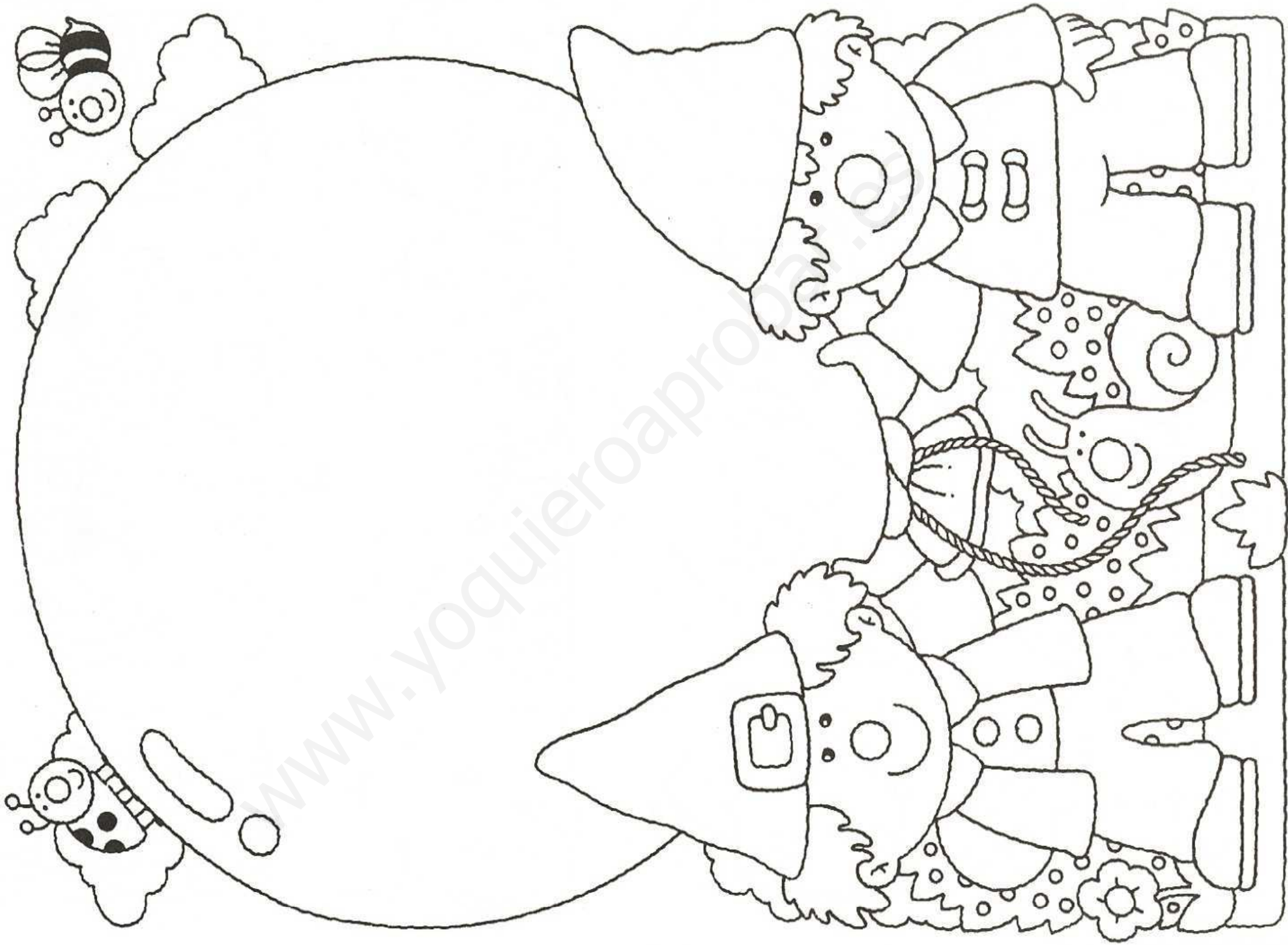

DECORA CON **MUCHAS** RAYAS EL TRAJE DEL PERRO QUE ESTÁ A LA DERECHA, CON **POCAS** EL DE LA IZQUIERDA Y CON **NINGUNA** EL DEL MEDIO.

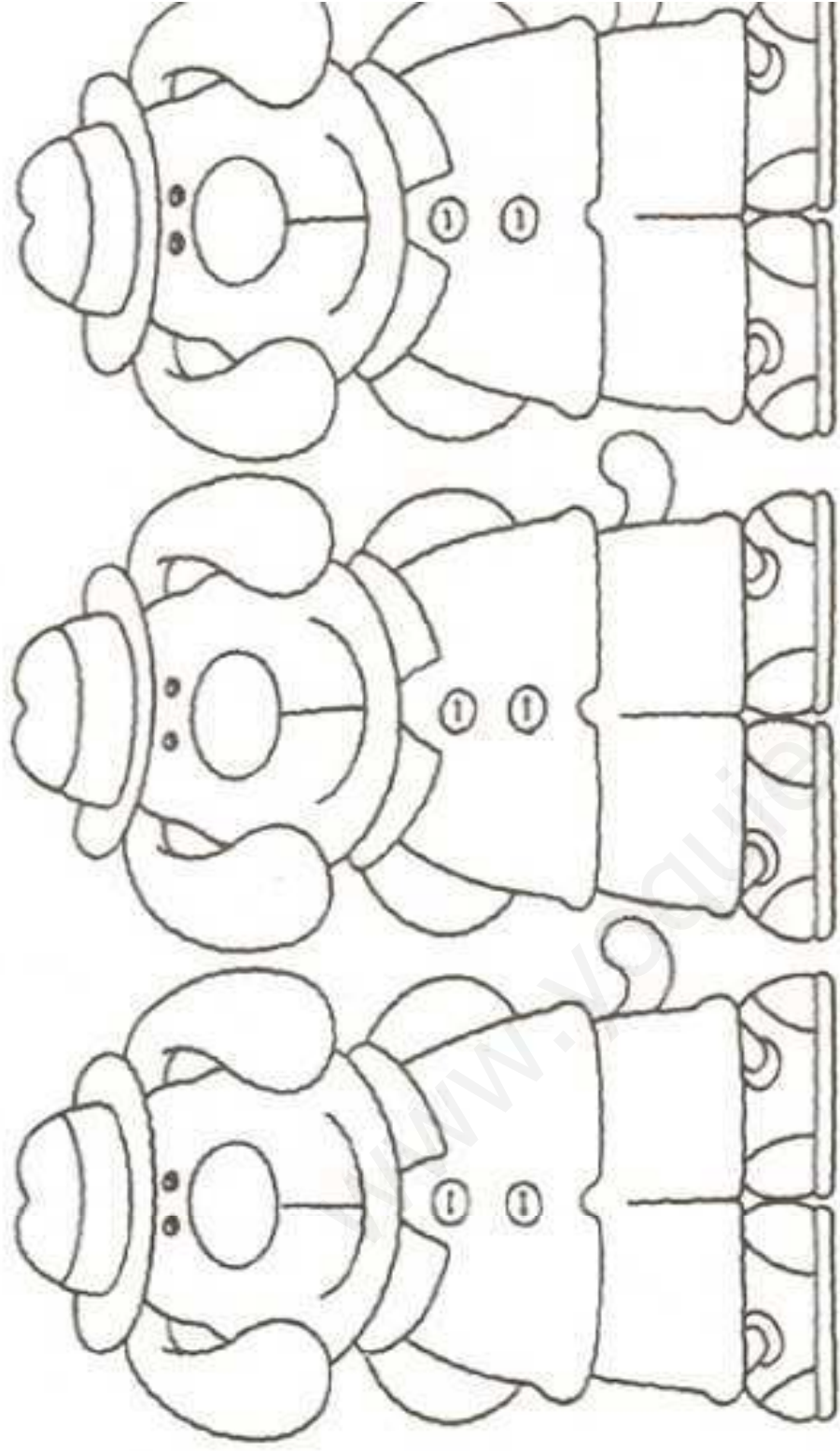

DIBUJA **MUCHOS** LUNARES EN EL VESTIDO DE LA IZQUIERDA, **ALGUNOS** EN EL DEL MEDIO Y **UNO** SOLO EN EL DE LA DERECHA.

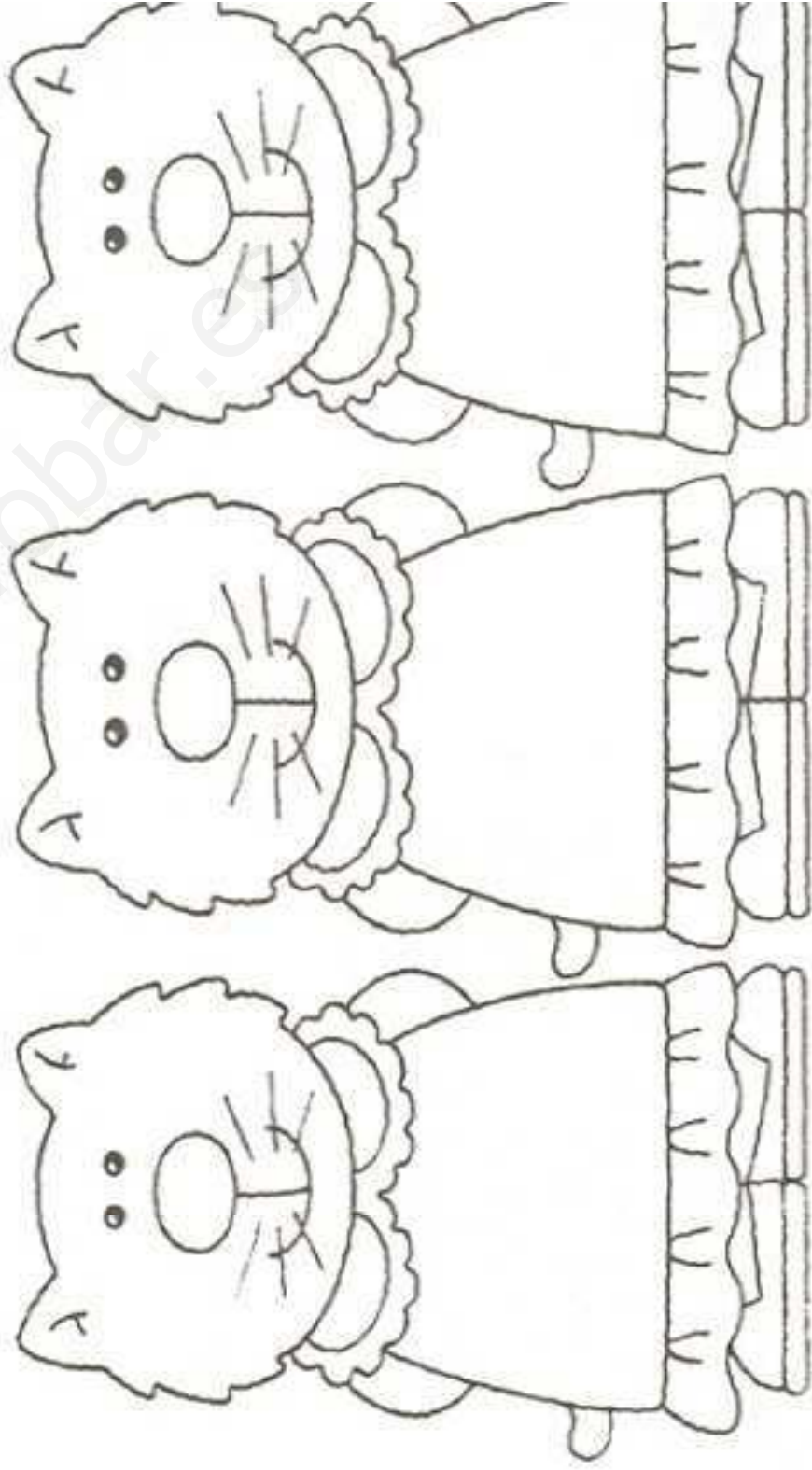

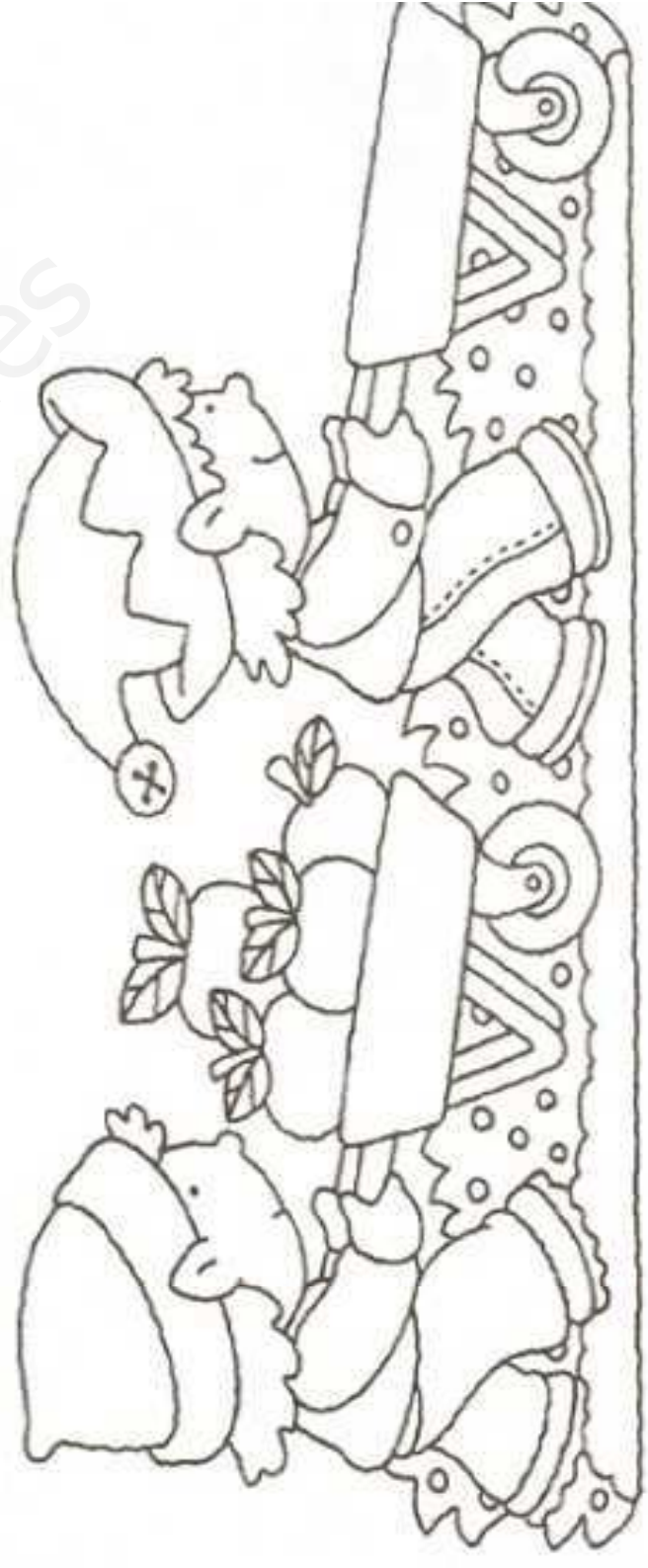
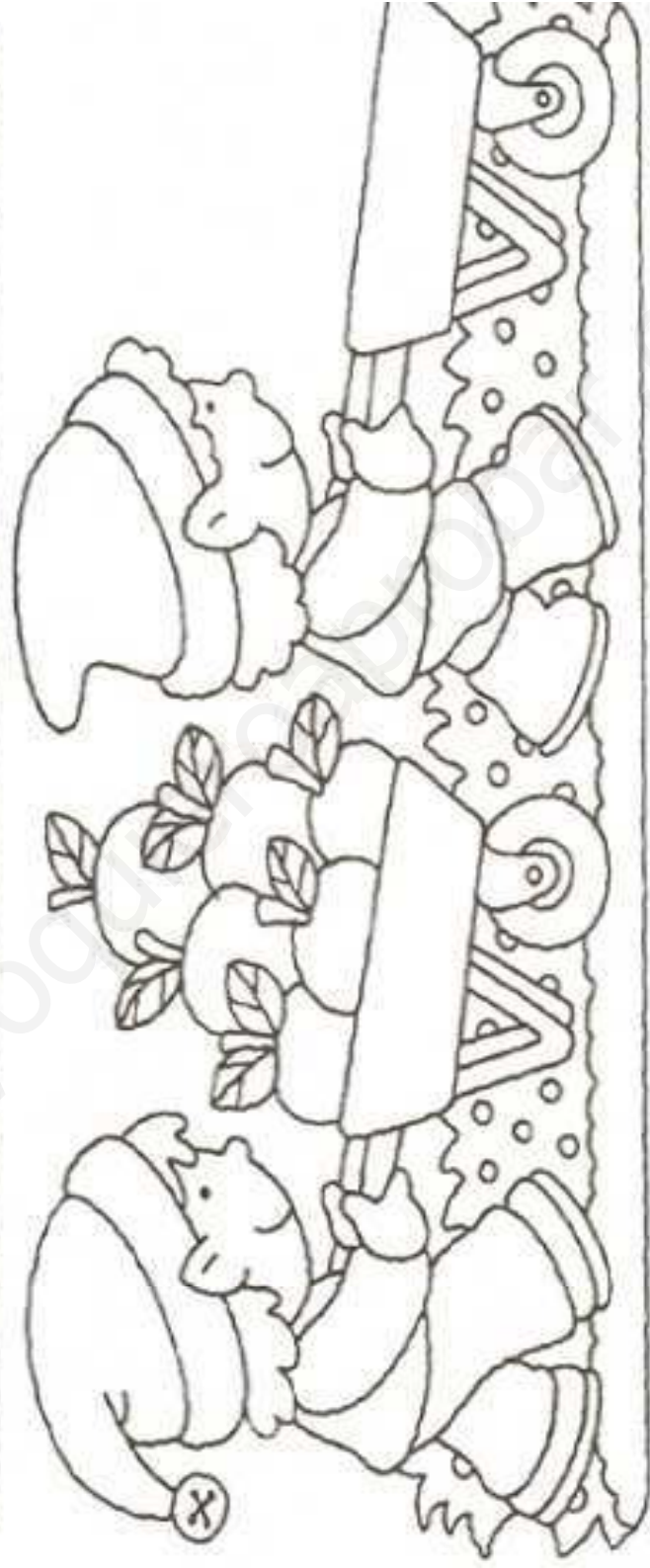
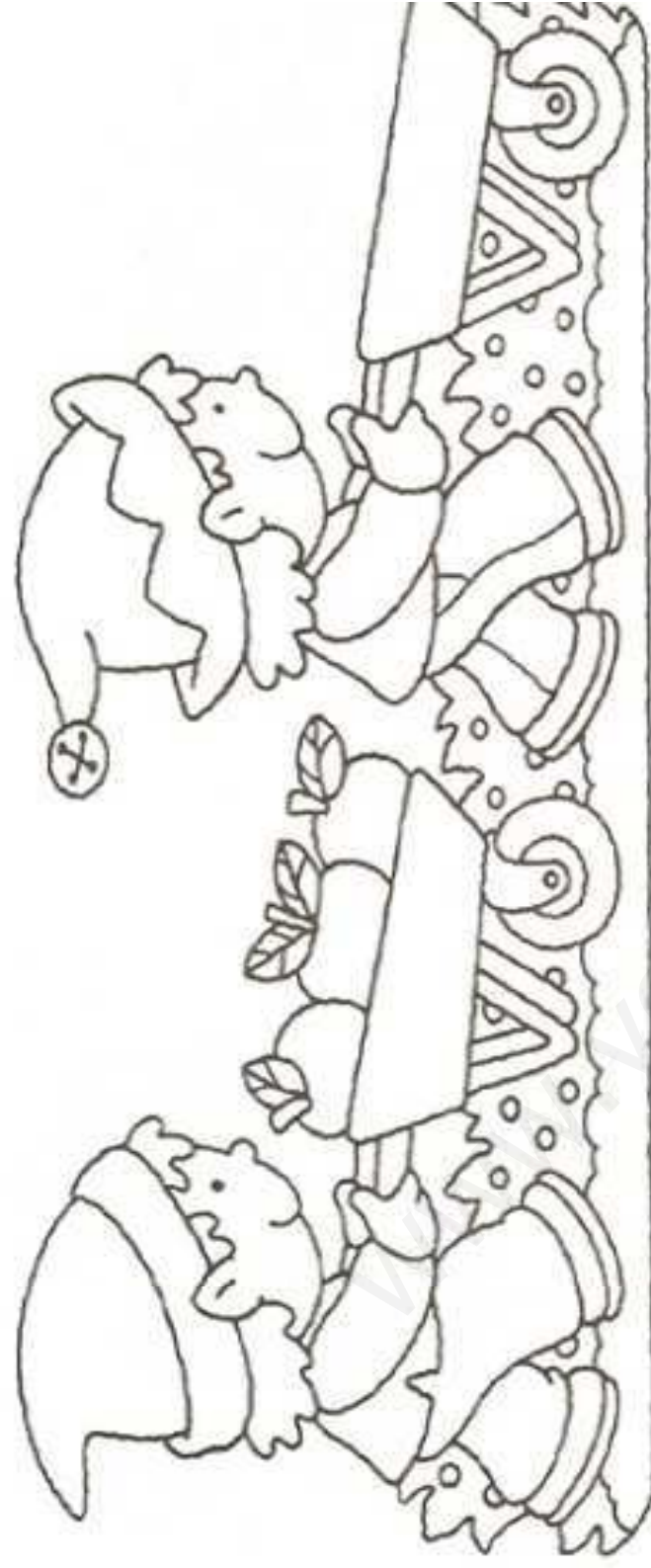

CUÁNTOS JUGUETES TENGO!

COLOREA DE LA MISMA MANERA LOS JUGUETES QUE SON IGUALES.

¿HAY MÁS TRENES QUE TROMPOS?

¿HAY MENOS TÍTERES QUE OSOS?

¿DE QUÉ JUGUETE TENGO UNO SOLO?

¿DE QUÉ JUGUETES TENGO LA MISMA CANTIDAD?

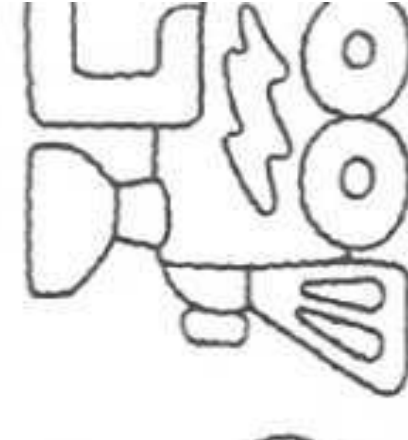
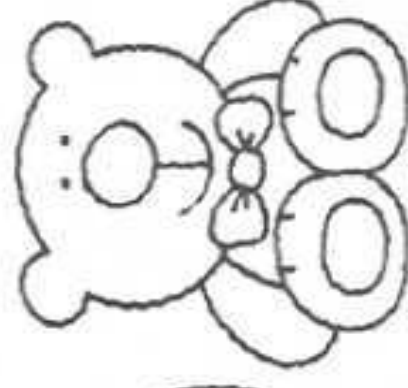
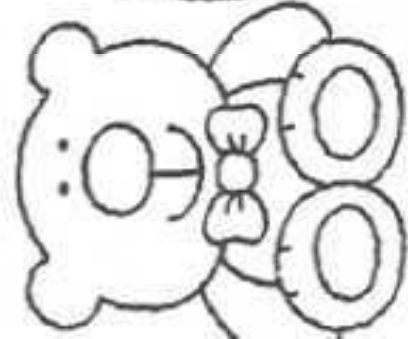
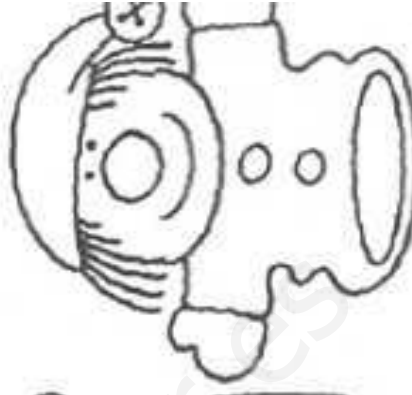
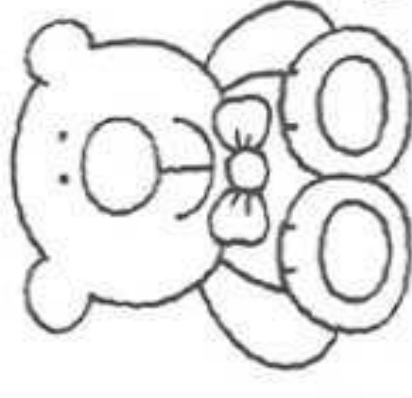
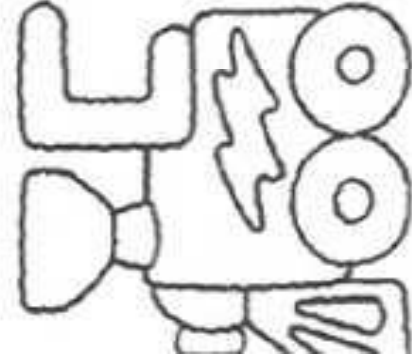
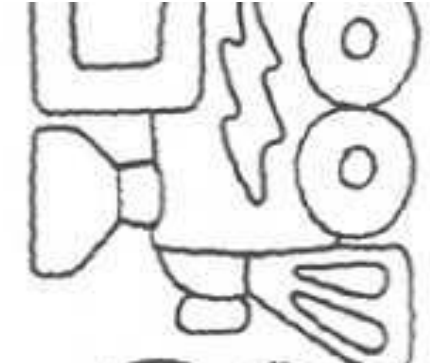
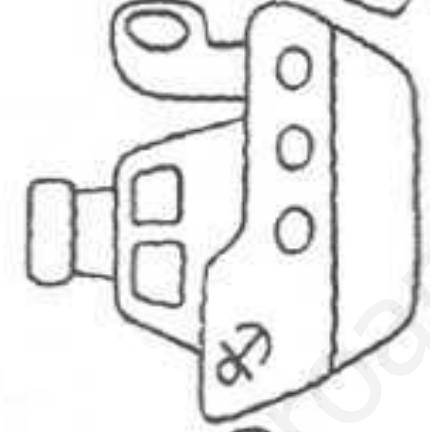
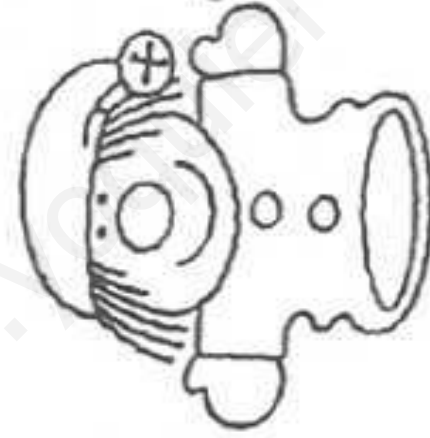
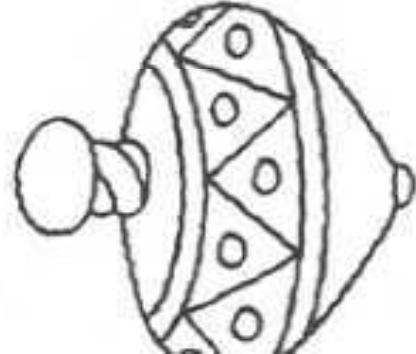
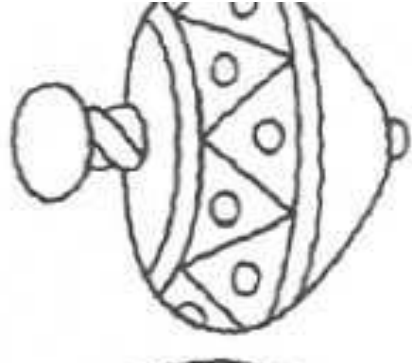
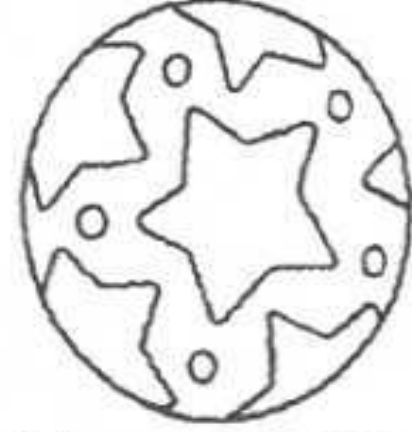
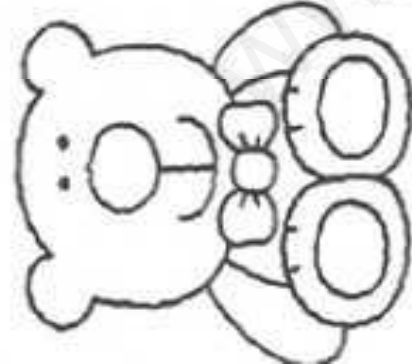

EN CADA CANTERO UNA FLOR **MENOS** QUE EN EL DE ARRIBA.

EN UNA CRUZ DEBAJO DEL OSITO QUE SE DURMIÓ.

ORDENA LAS IMÁGENES.

¿QUANTAS FLORES TIENE EL OSITO DORMIDO EN SU CANTERO?

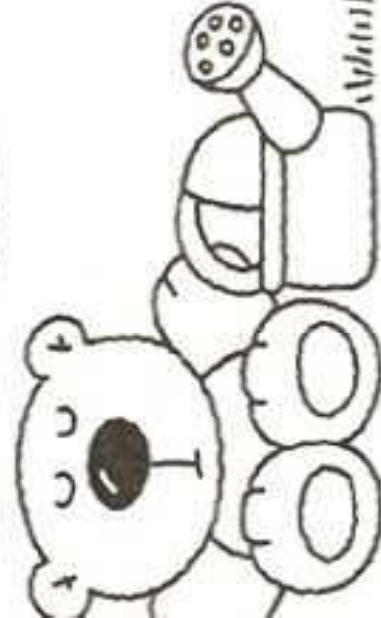
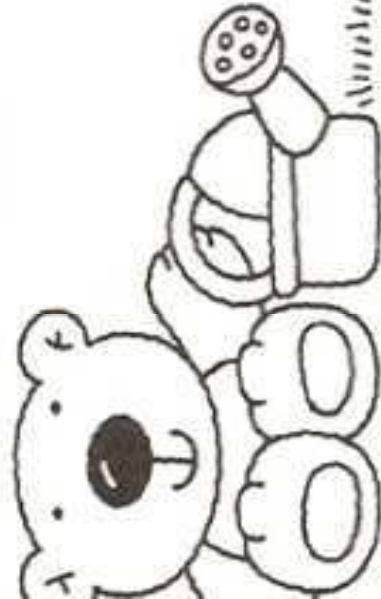
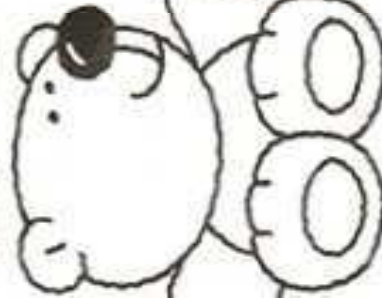
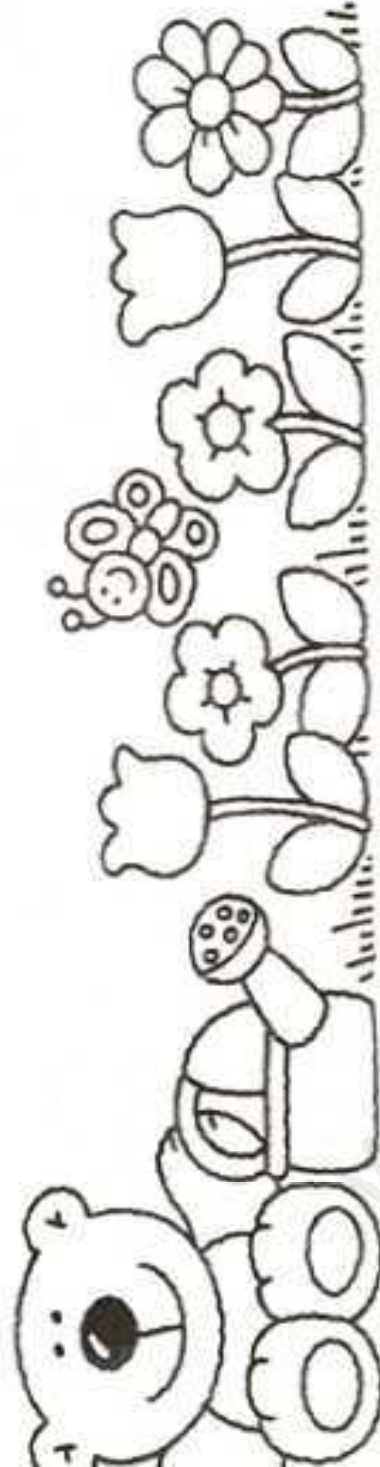

www.cucleroapropar.es

www.cucleroapropar.es

www.cucleroapropar.es

www.cucleroapropar.es

¡YO SOY UNO SOLO!

- DIBUJA Y COLOREA EL CUERPO COMPLETO.
- COLOREA LOS JUGUETES.

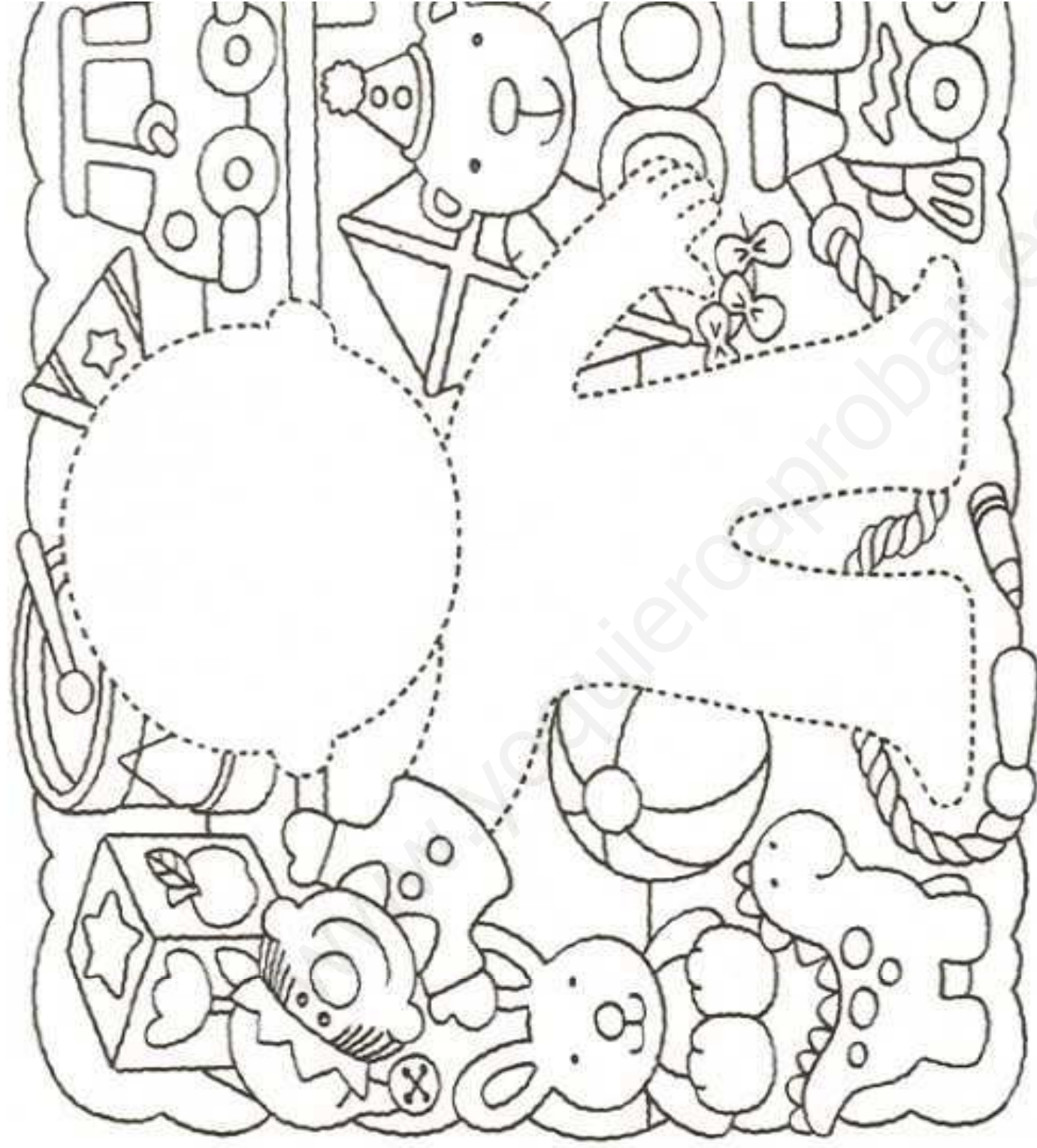

• ¿CUÁNTOS JUGUETES HAY? ESCRIBE EL NÚMERO EN CADA CASILLERO.

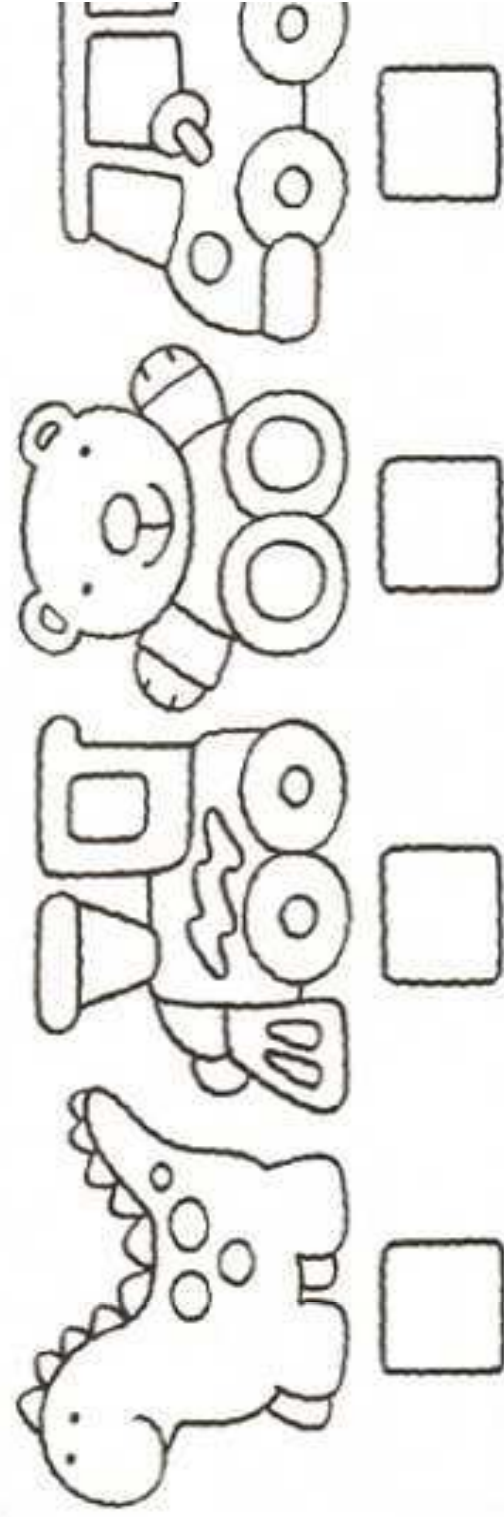

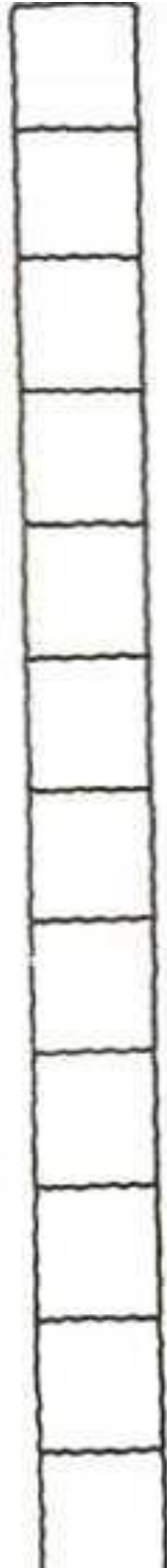

¡¡HOLA, SOMOS NOSOTROS DOS!
 OBSERVA Y DESCUBRE DÓNDE PUEDES CONTAR DOS.
 ESCRIBE EL NÚMERO QUE CORRESPONDE EN CADA CASILLERO.

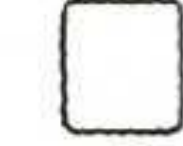
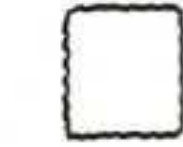
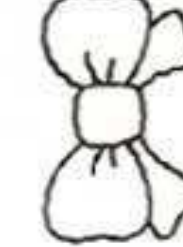
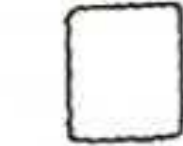
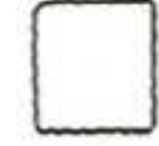
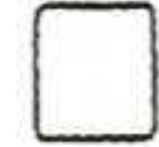
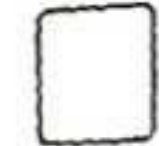
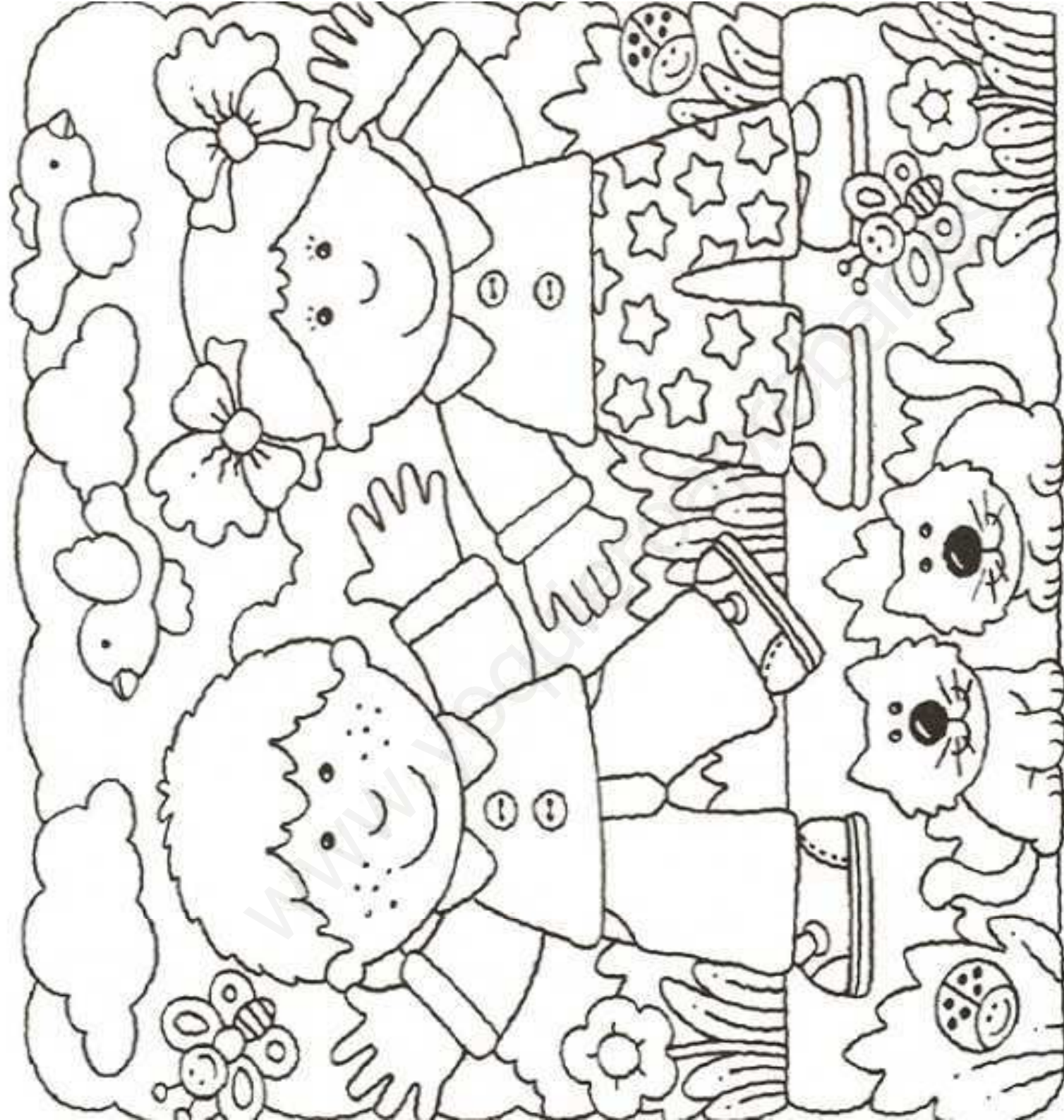

A BUSCAR!

COLOREA DONDE HAY **DOS** ELEMENTOS.

PARA OBSERVAR: A LA DERECHA DE _____ HAY _____ HAY _____

A LA IZQUIERDA DE _____ HAY _____ HAY _____

ARRIBA DE _____ HAY _____ HAY _____

ABAJO DE _____ HAY _____ HAY _____

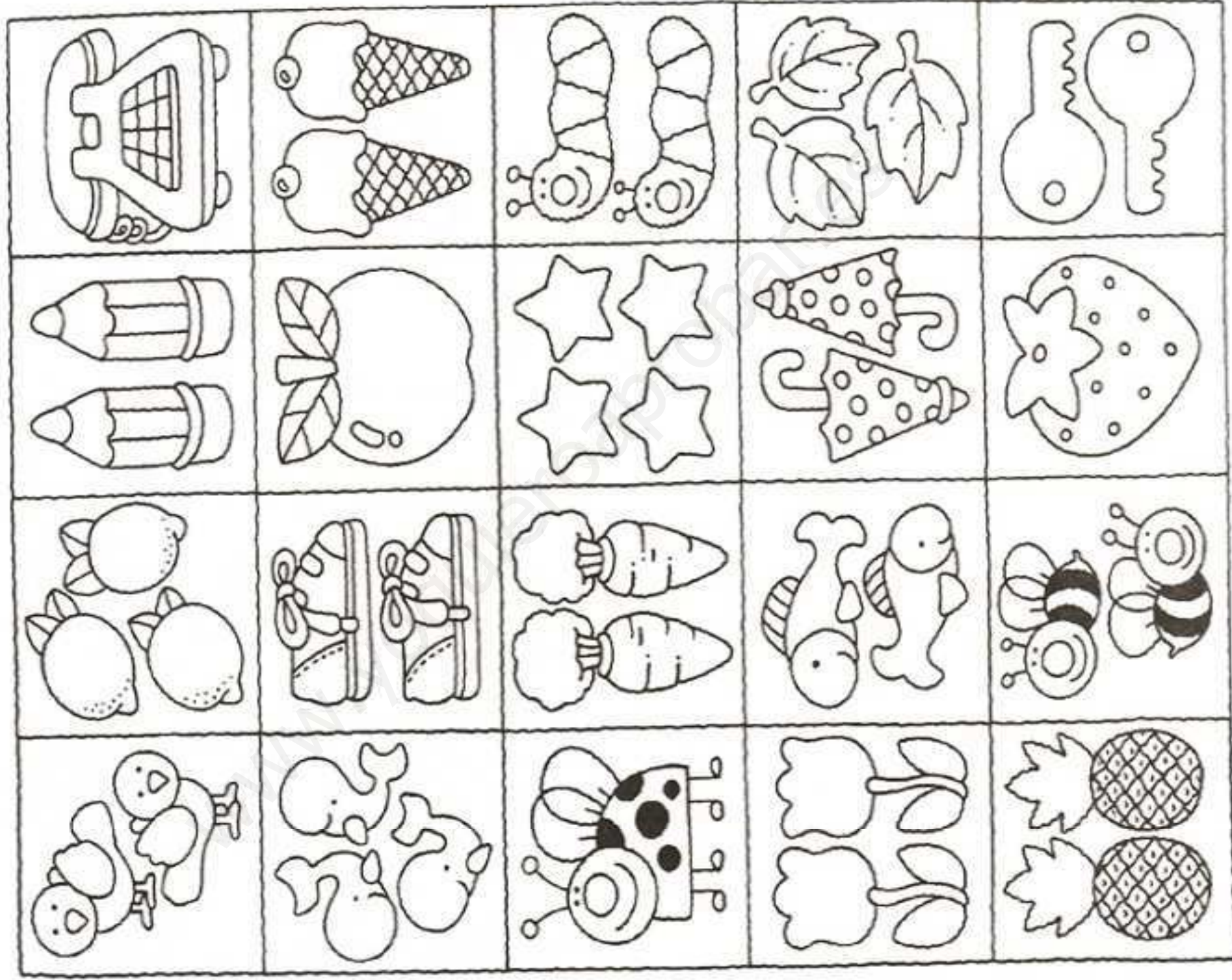

LA, SOMOS LOS TRES OSITOS AMIGOS!

¿É ROPA PUEDE PONERSE CADA UNO? UNE CON UNA LÍNEA CADA OSITO CON SUS

47

INDAS.

COLOREA LA ROPA.

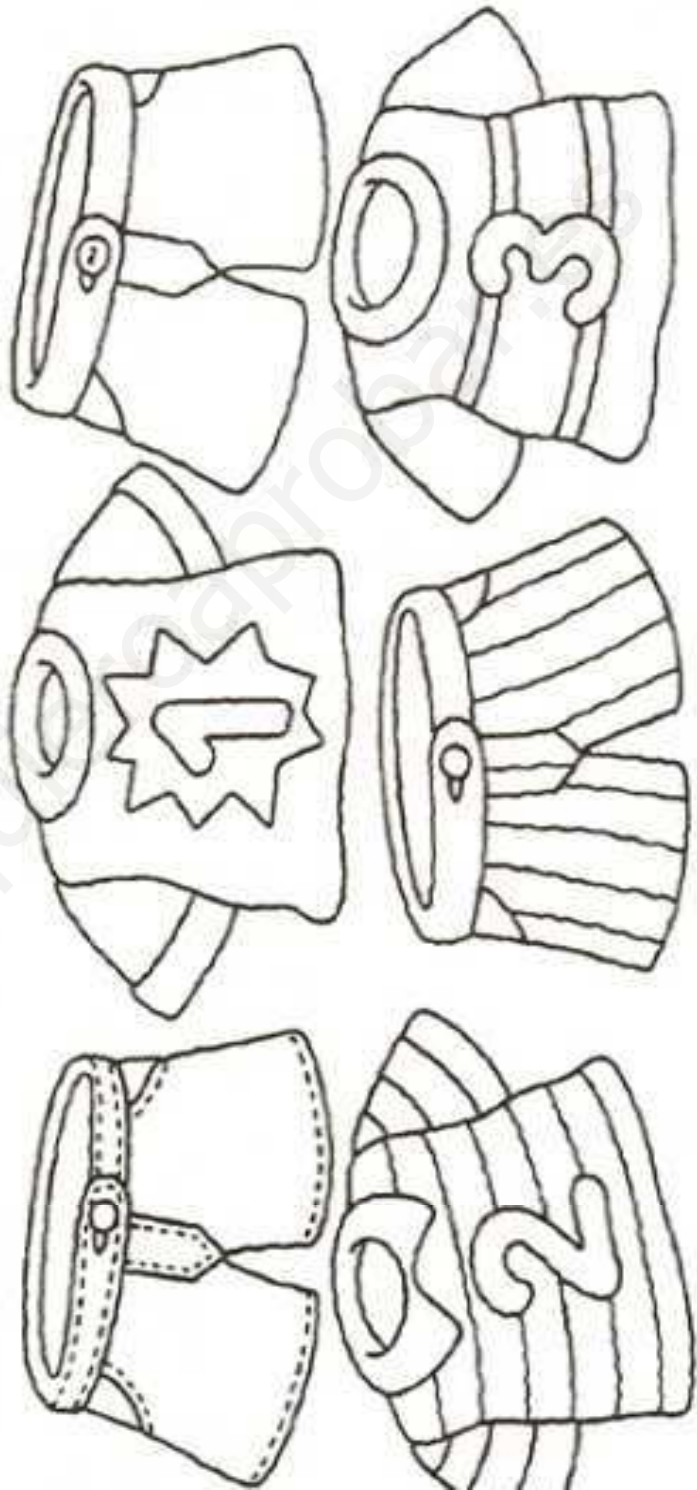
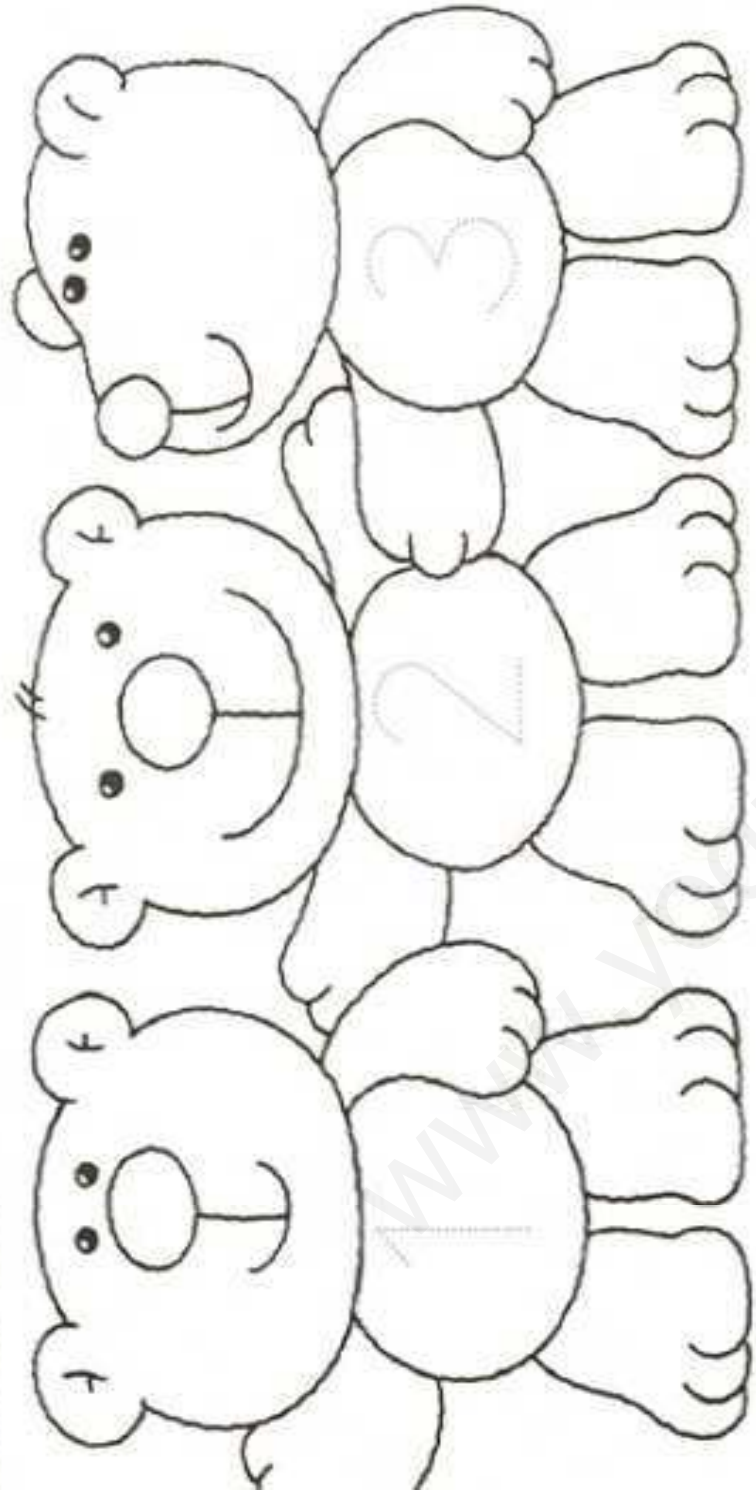

E CON UNA LÍNEA CADA PAR DE MEDIAS. COLOREA.
¿CÓMO PUEDE PONERSE CADA UNO? ¿ALCANZAN PARA LOS TRES OSITOS?



ESCRIBE EN CADA VAGON EL NÚMERO DE ANIMALITOS QUE LLEVA.

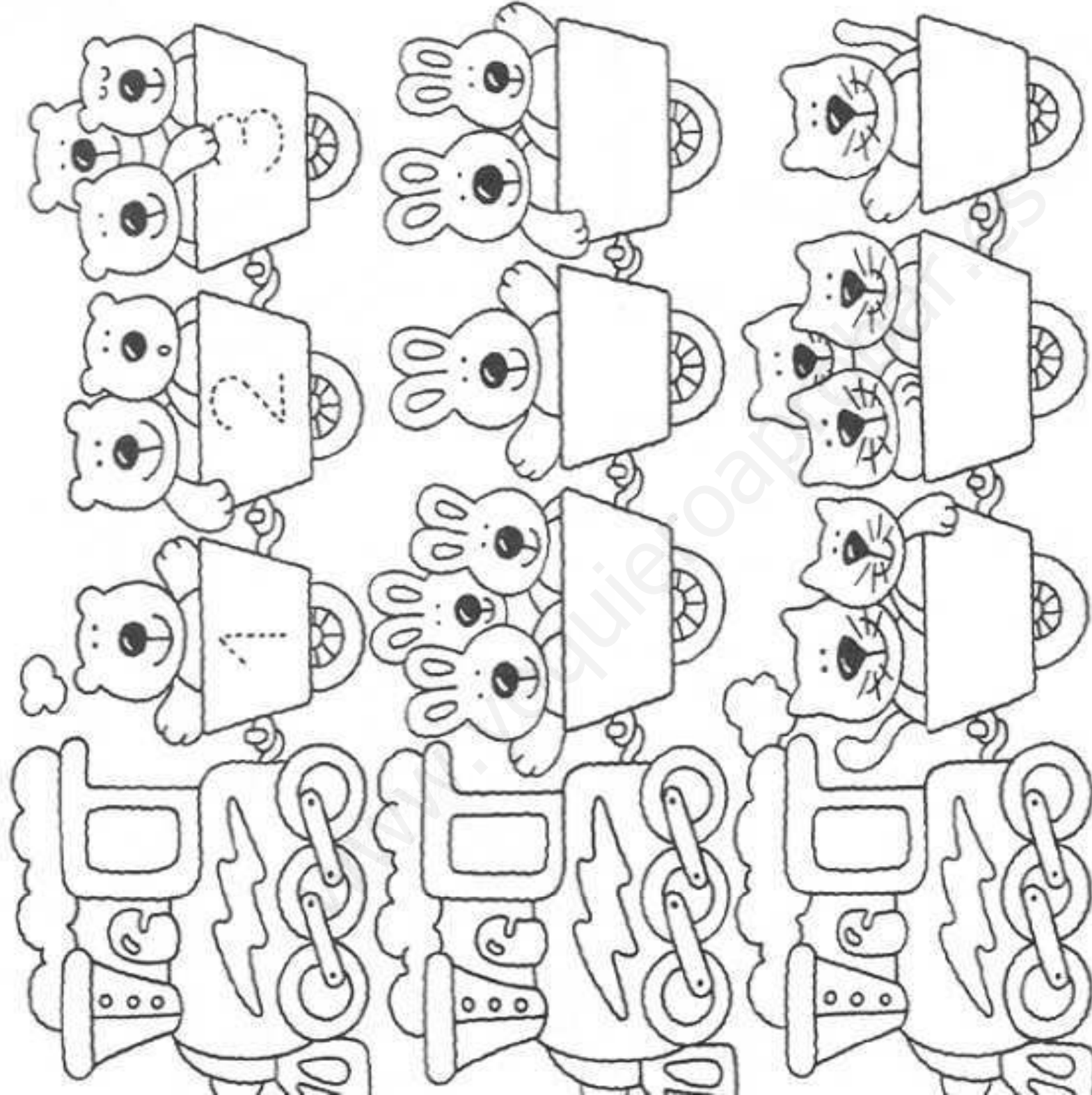

OBSERVA Y REPITE LA SECUENCIA EN VOZ ALTA.
JUEGO COMPLETALA.

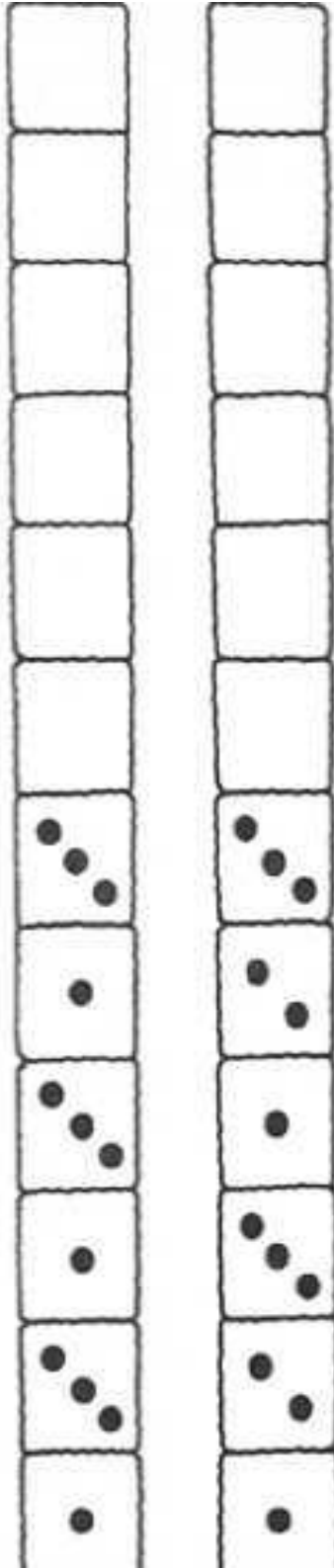

¡HOLA, NOS SUBIMOS LOS CUATRO!

- ESCRIBE EN EL CASILLERO CORRESPONDIENTE EL NÚMERO DE ANIMALES QUE HAY EN CADA COLUMNA.

- COLOREA LOS ANIMALES.

- SEÑALA CON UNA X EL ANIMAL QUE ESTÁ MÁS ALTO DE TODOS.

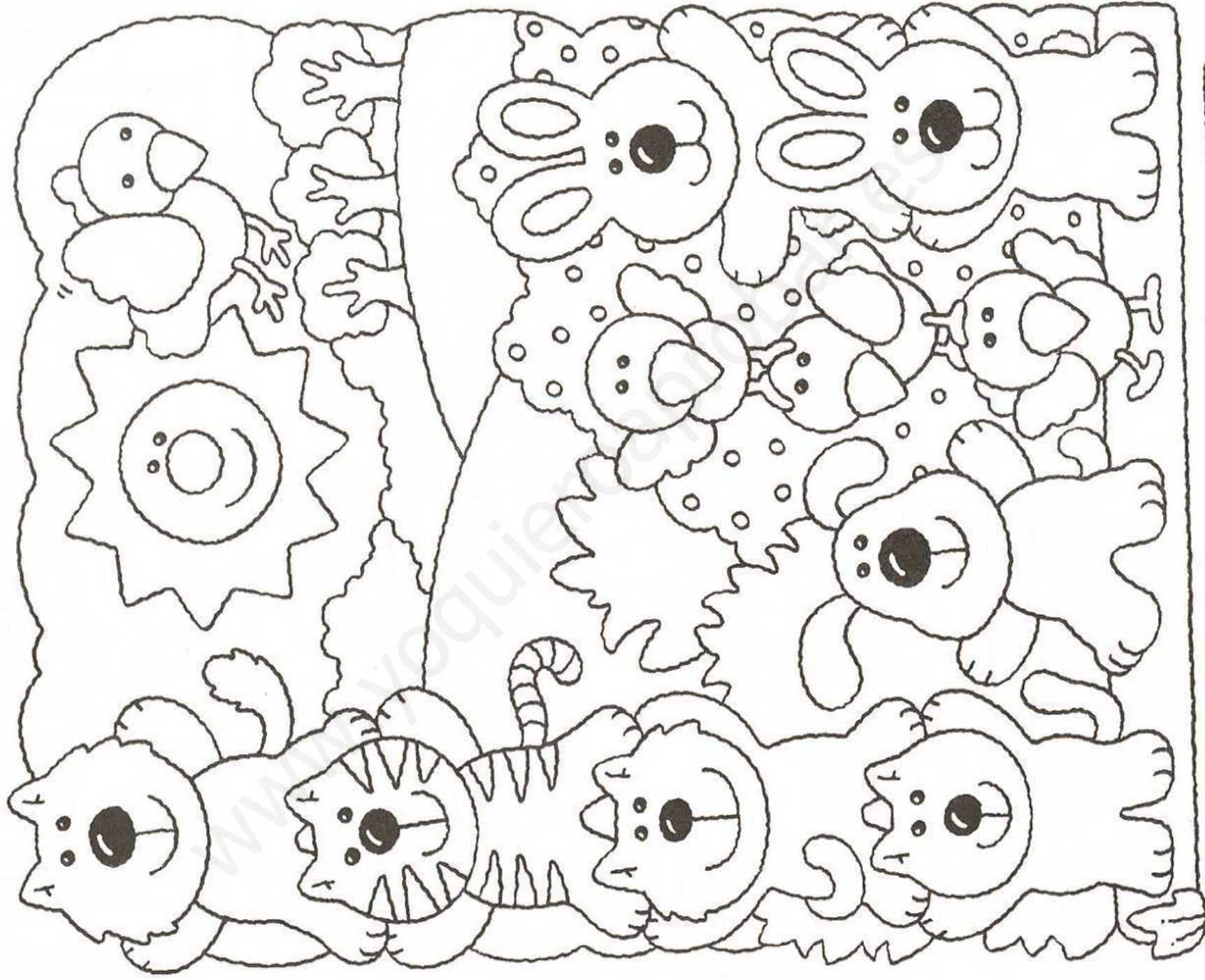







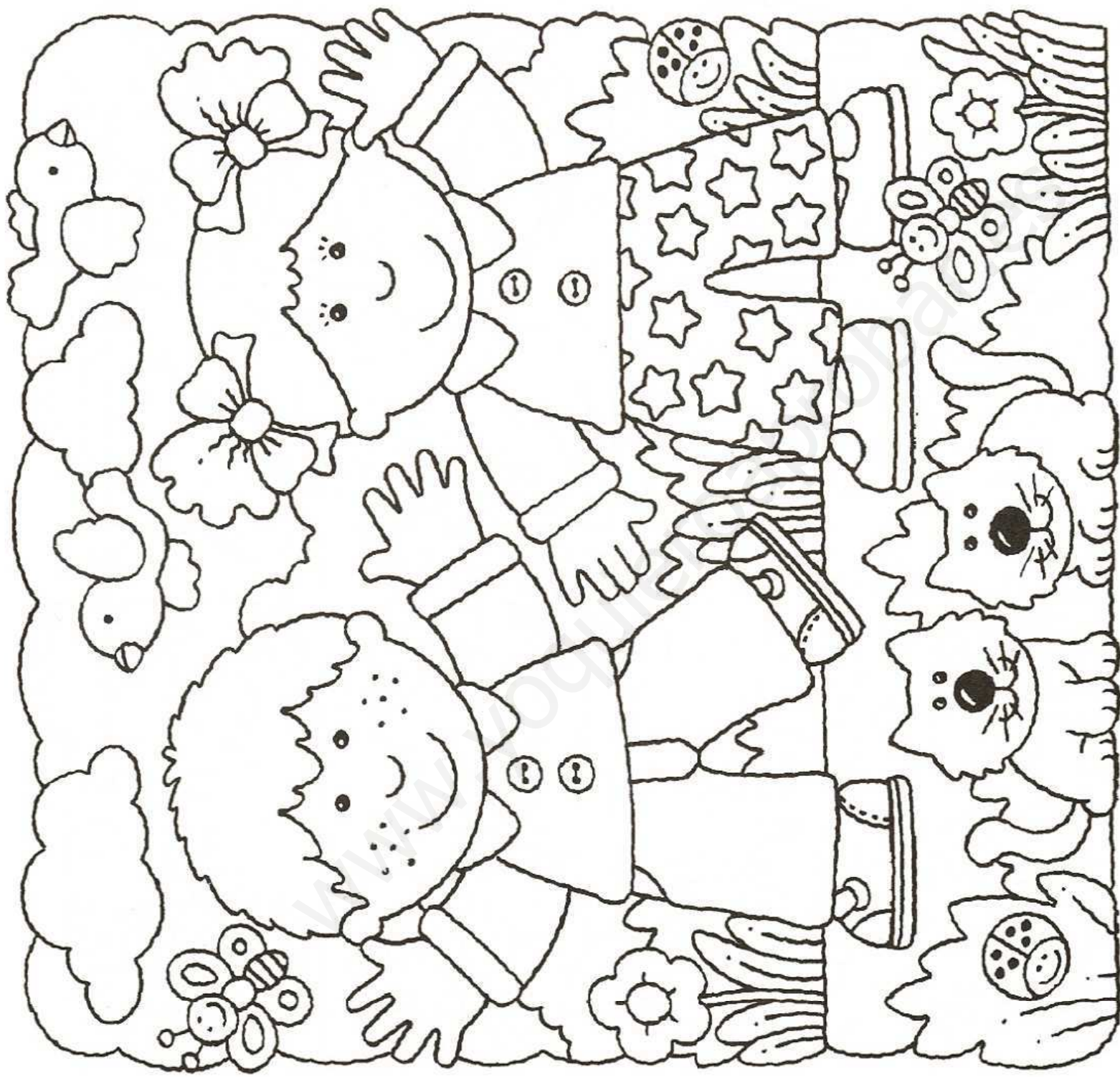

<input type="checkbox"/>	<input type="checkbox"/>	<input type="checkbox"/>	<input type="checkbox"/>	<input type="checkbox"/>
--------------------------	--------------------------	--------------------------	--------------------------	--------------------------

¡HOLA, SOMOS NOSOTROS DOS!

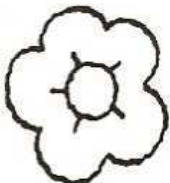
- OBSERVA Y DESCUBRE DÓNDE PUEDES CONTAR DOS.
- ESCRIBE EL NÚMERO QUE CORRESPONDE EN CADA CASILLERO.



	<input type="checkbox"/>		<input type="checkbox"/>
	<input type="checkbox"/>		<input type="checkbox"/>
	<input type="checkbox"/>		<input type="checkbox"/>
	<input type="checkbox"/>		<input type="checkbox"/>

¡AU, NOS VAMOS LOS CINCO A DORMIR!
LINEA LOS NÚMEROS DE CADA COLLAR.

51

¡UJA EN EL LOMO DE CADA CACHORRO TANTOS LUNARES COMO INDICA EL COLLAR.



¡UJA EN EL LOMO DE CADA CACHORRO TANTOS LUNARES COMO INDICA EL COLLAR. ¿ALCANZAN? ¿SOBRA
ALGUNO?

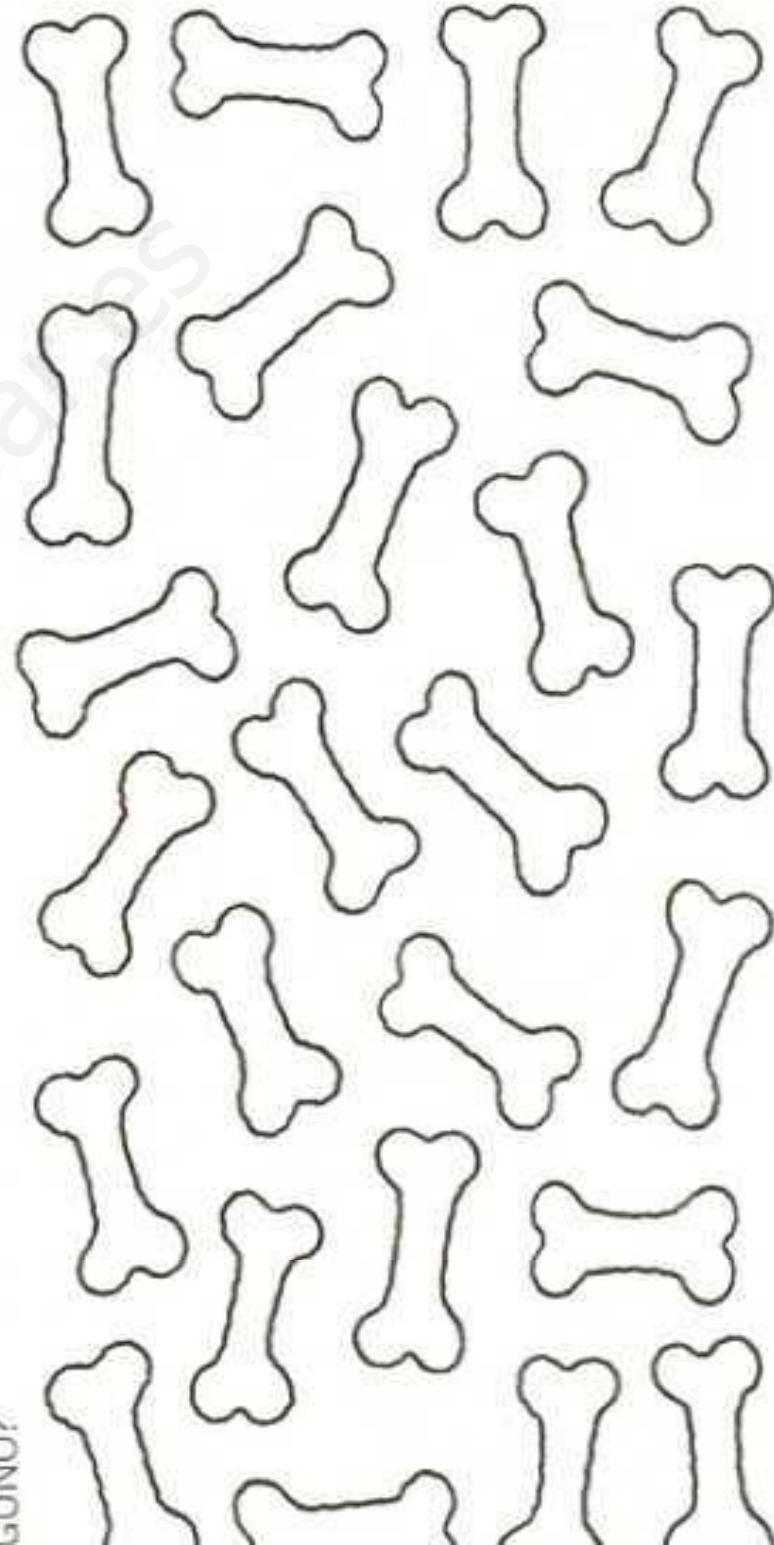

¡DIBUJA Y DECORA LOS CINCO BONETES.

¡DIBUJA CINCO VELITAS EN LA TORTA Y UNA PORCIÓN DE TORTA EN CADA PLATO.

¡COMPLETA CON JUGO LOS CINCO VASOS.

¡DIBUJA Y DECORA LOS CAMELOS. ¿CUÁNTOS HAY? ¿ALCANZAN?

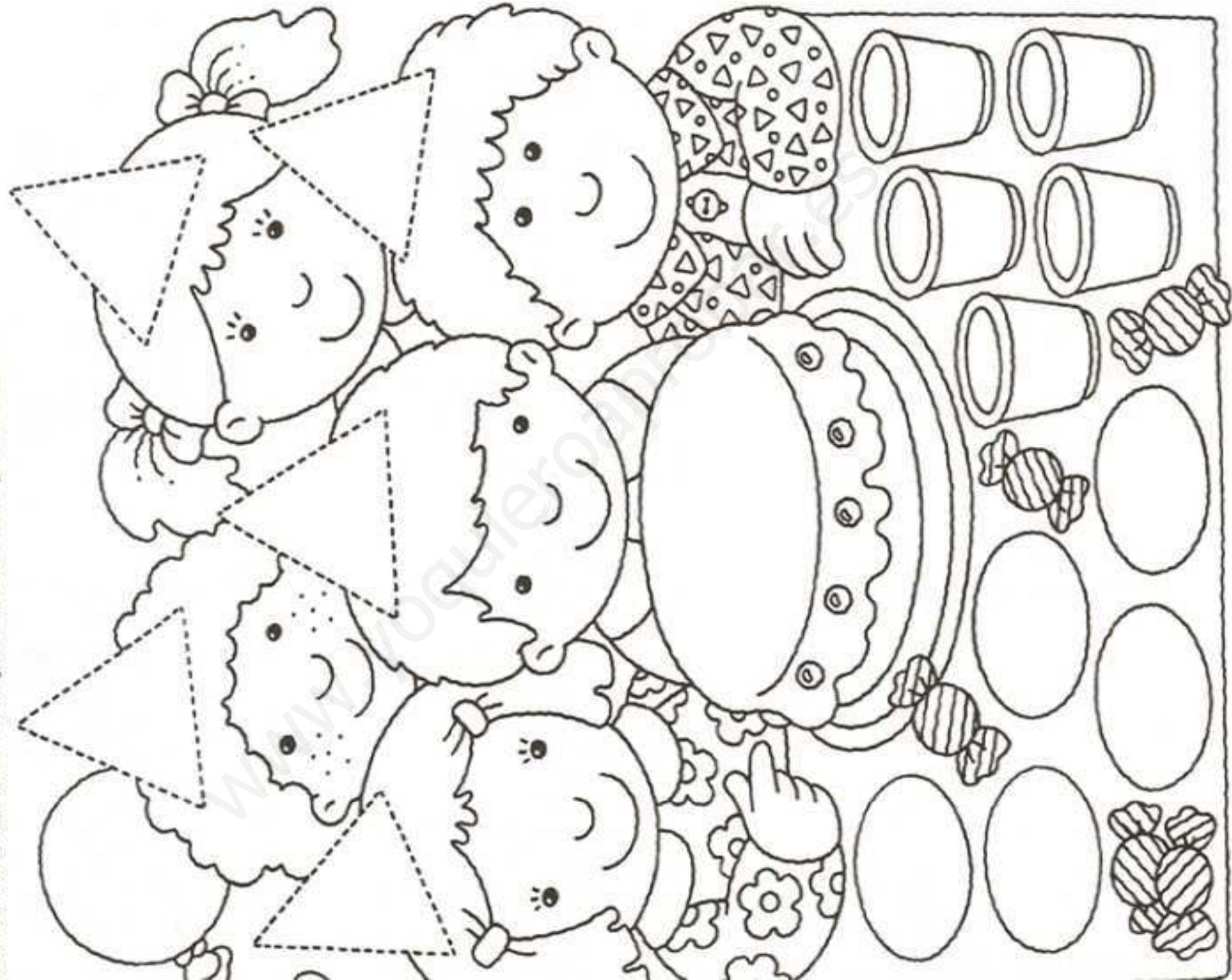

COLOREA LOS NÚMEROS EN LA DIRECCIÓN CORRECTA.
UNE CON UNA LÍNEA LA CANTIDAD DE OBJETOS CORRESPONDIENTES.
COLOREA LOS ANIMALITOS.

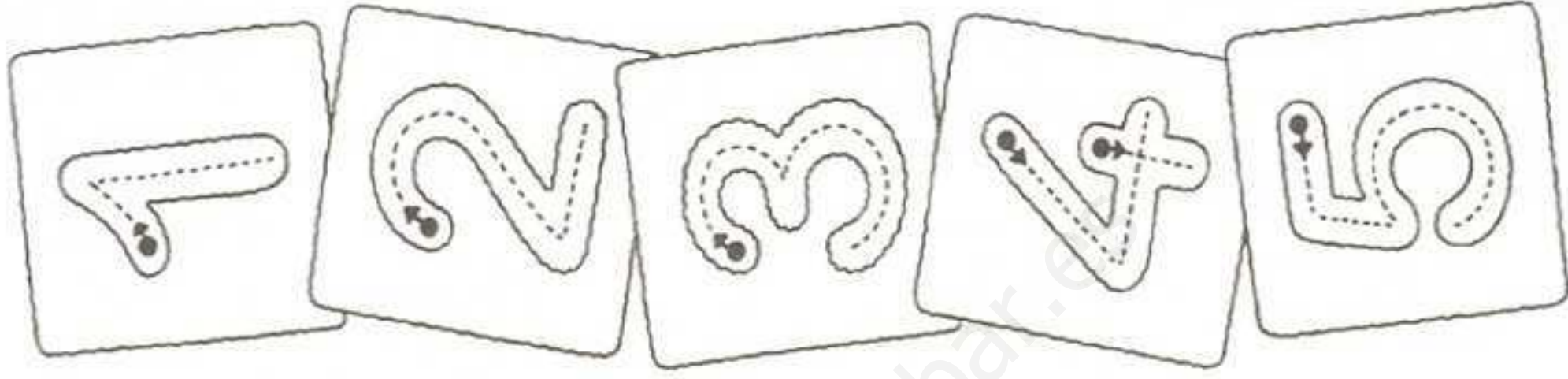
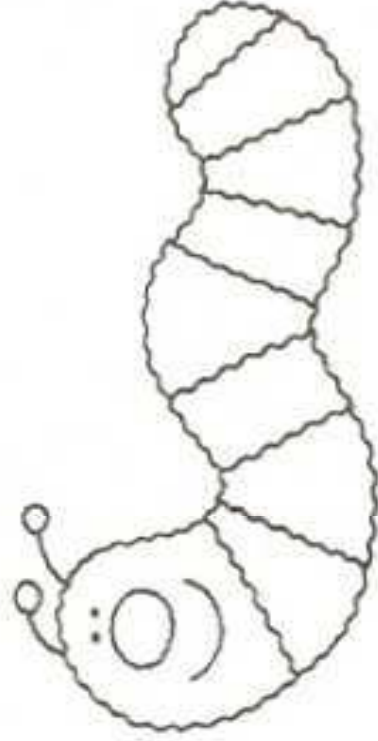
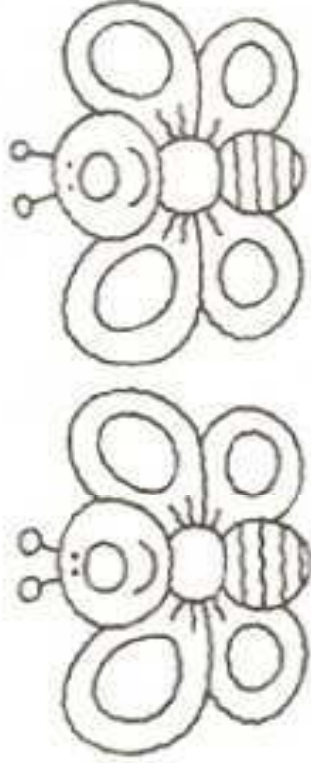
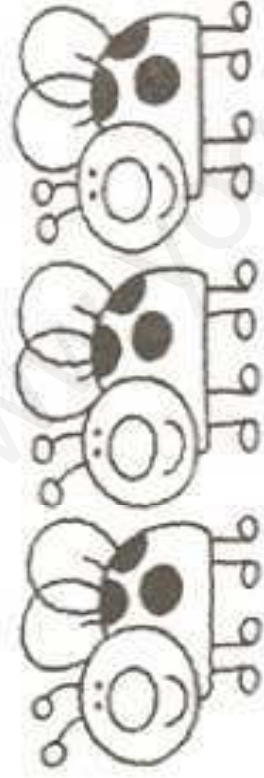

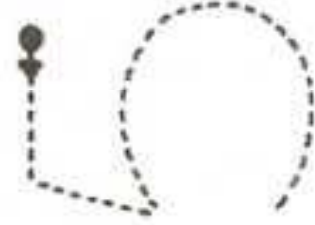
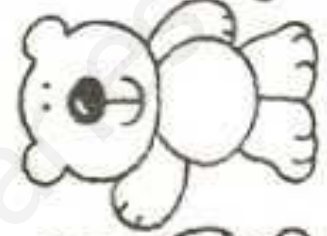
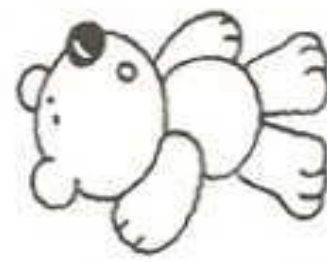
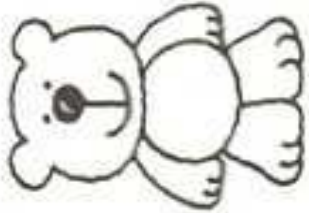
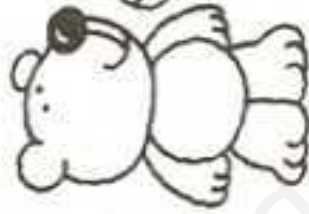
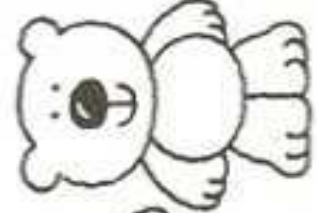

¡HOLA, PREPARÉ SEIS DELICIOSAS PIZZAS!



- CUENTA LAS PIZZAS QUE HIZO EL COCINERO. SON
- ESCRIBE DEBAJO DE CADA PIZZA CUÁNTAS PORCIONES TIENE.
- COLOREA LAS PIZZAS QUE TIENEN **SEIS** PORCIONES.

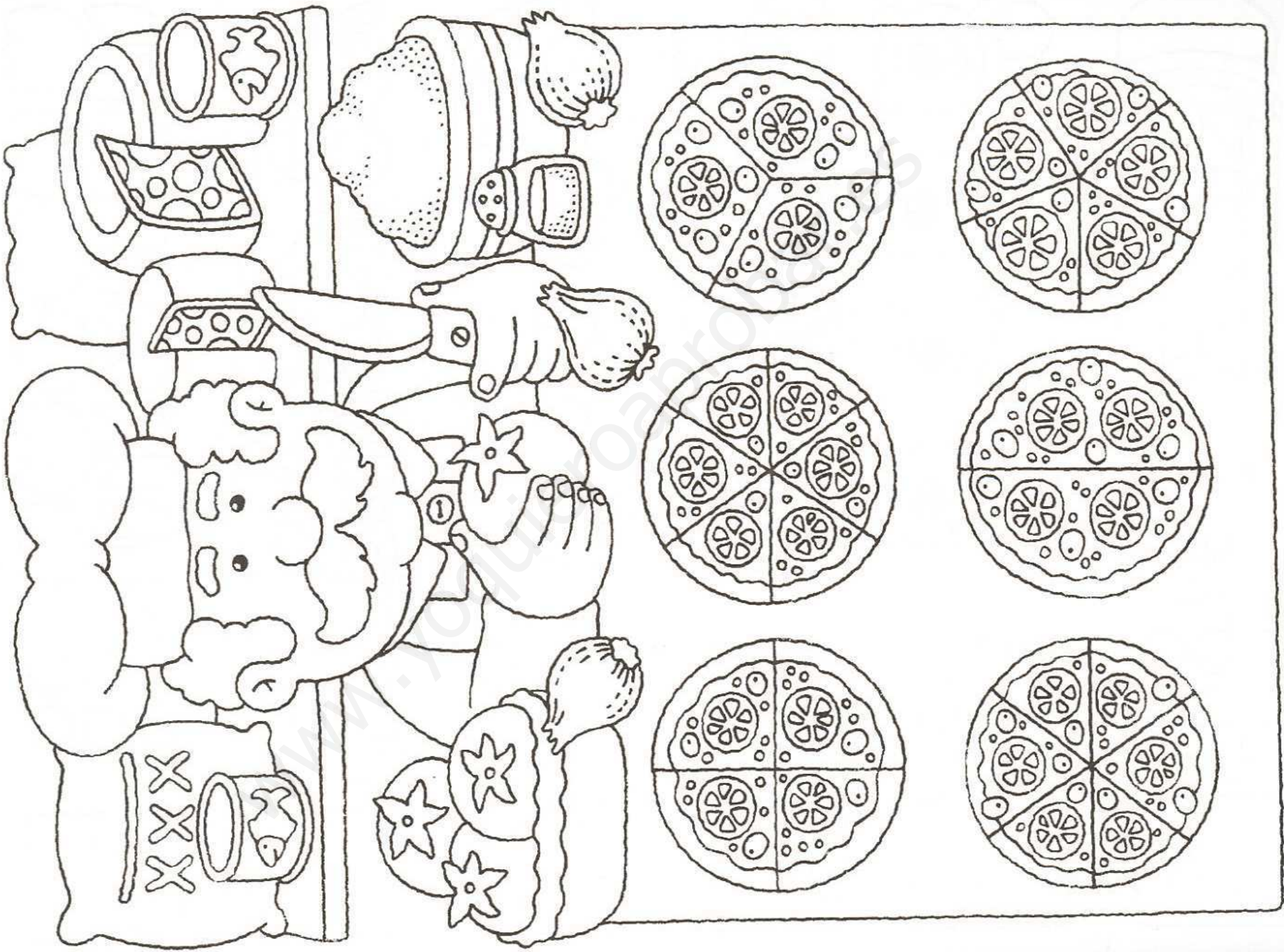

A COMPLETAR LAS FLORES CON LA MISMA CANTIDAD DE PÉTALOS!

56

¿CUÁNTOS PÉTALOS TIENE CADA FLOR?

COLOREA LAS FLORES QUE ESTÁN A LA IZQUIERDA DE LOS ANIMALITOS.

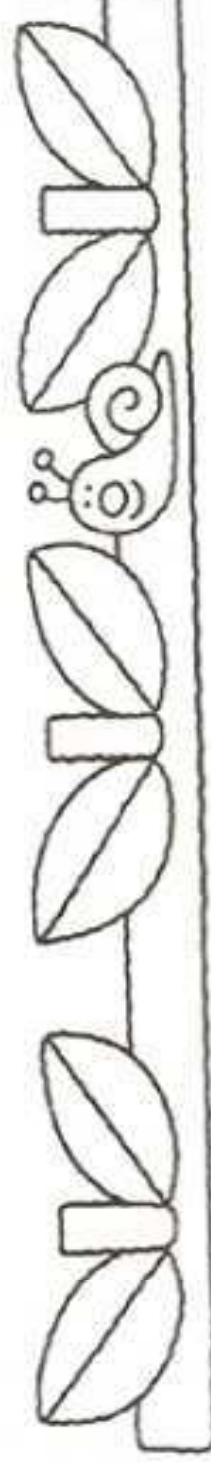
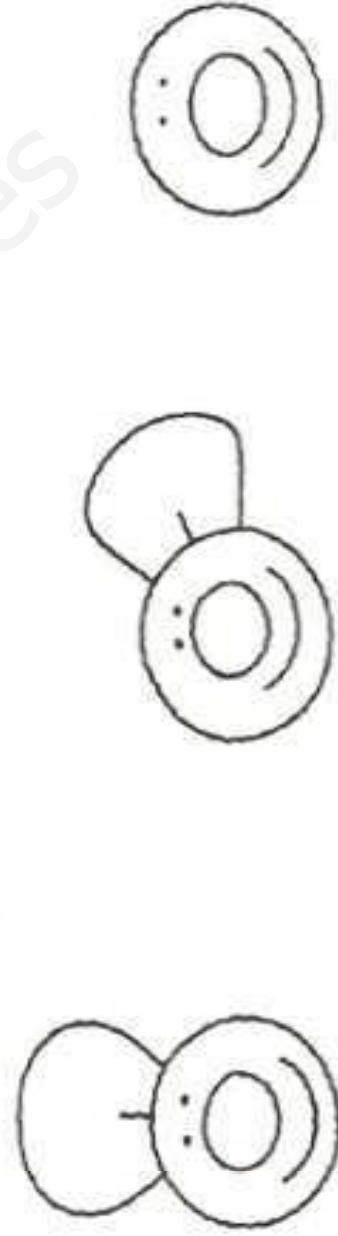
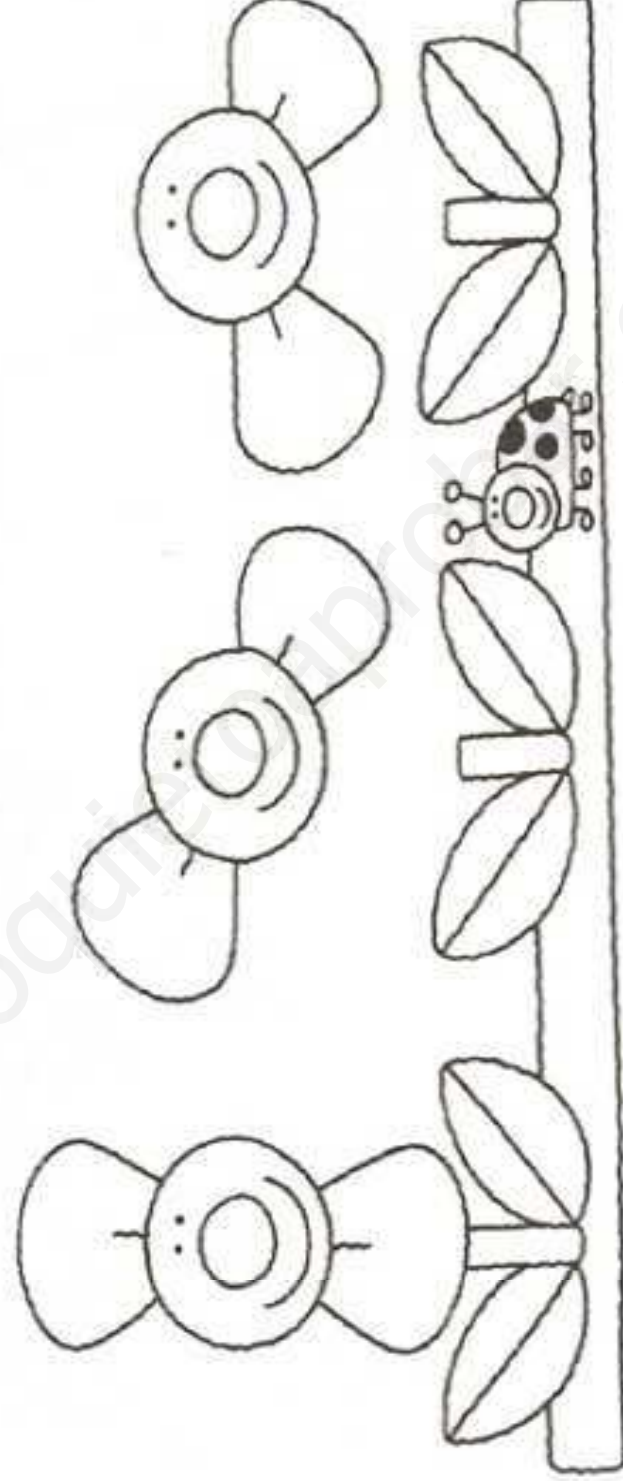
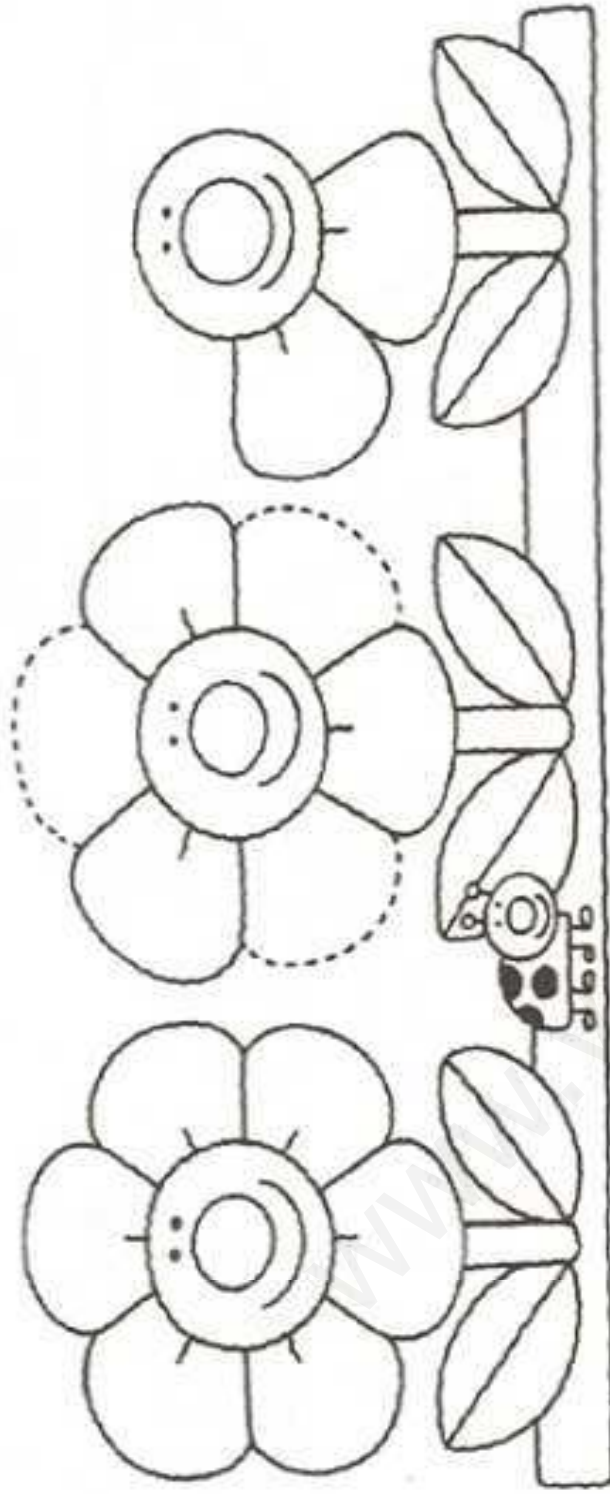

¡HOLA, SOMOS LOS SIETE ENANITOS! ¿LA CONOCES A BLANCANIEVE?
 • COLOREA LA IMAGEN.

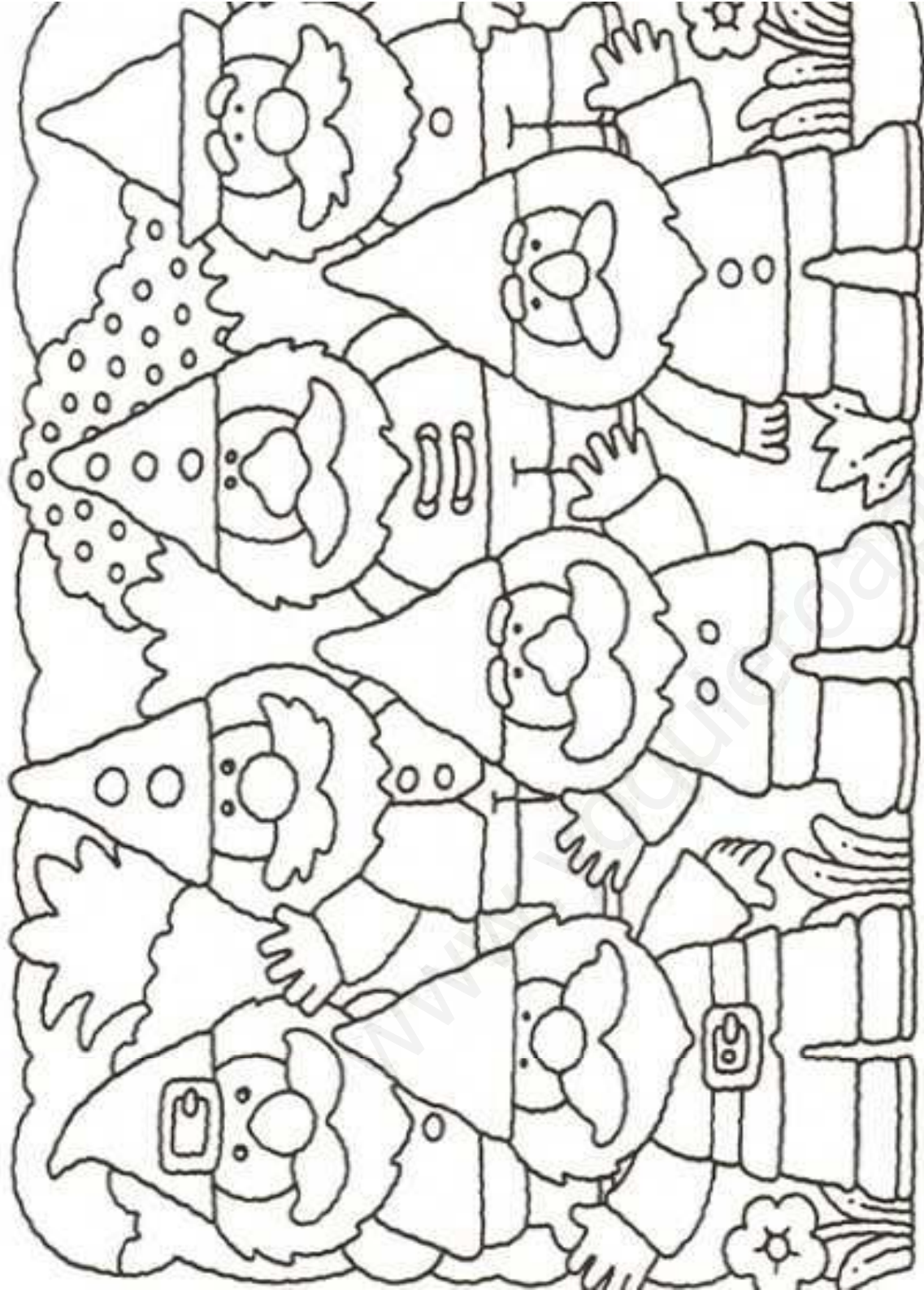

LLENA CON JUGO TANTOS VASOS COMO ENANOS HAY.

¿ALCANZAN? ¿SOBRAN? ¿CUÁNTOS?

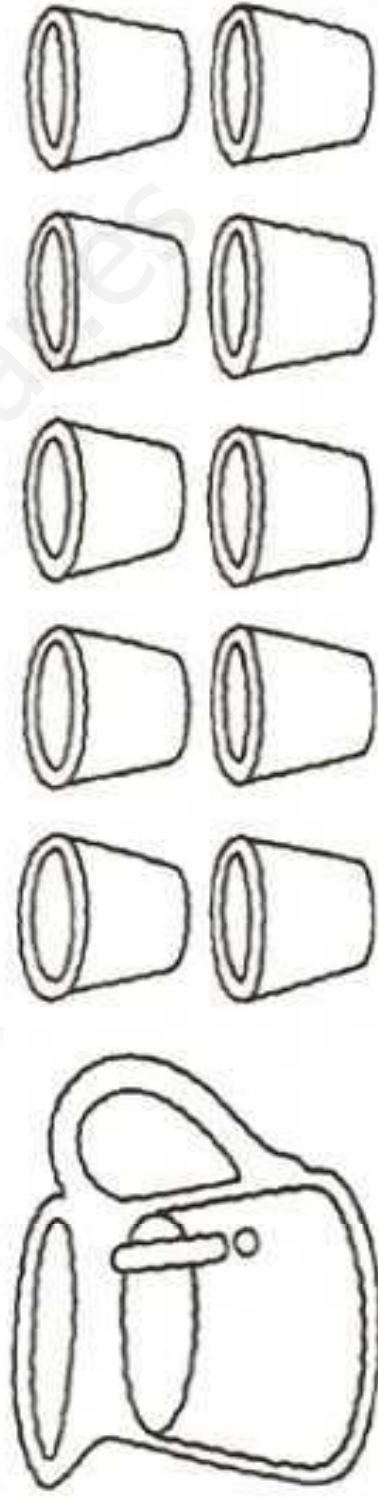

COLOREA LAS SIETE MANZANAS QUE SE COMERÁN LOS ENANITOS.

¿SOBRAN? ¿CUÁNTAS?

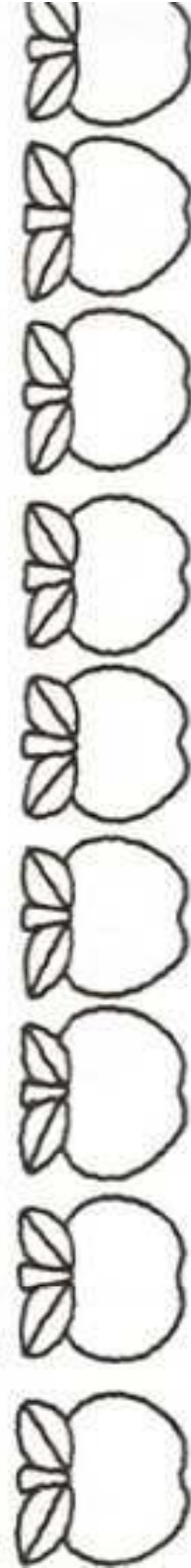

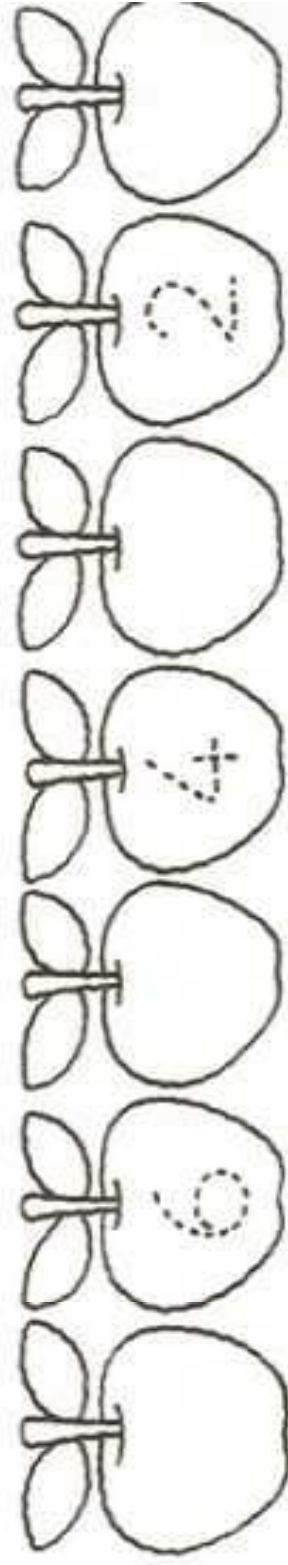
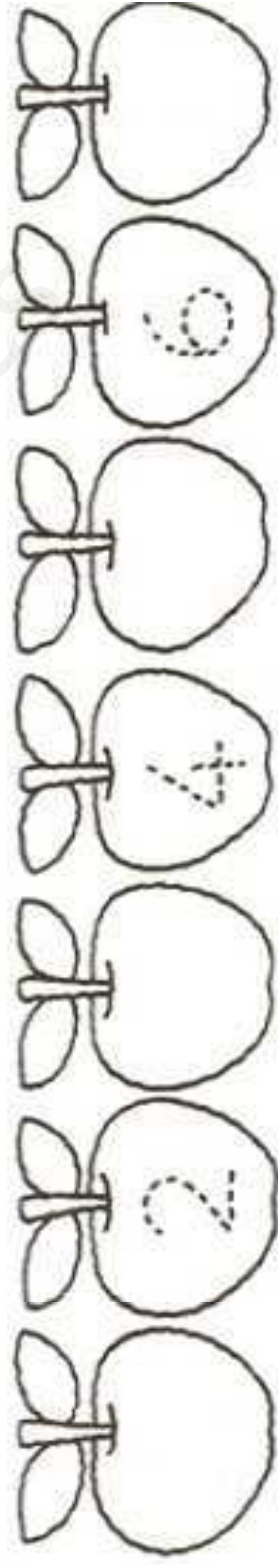
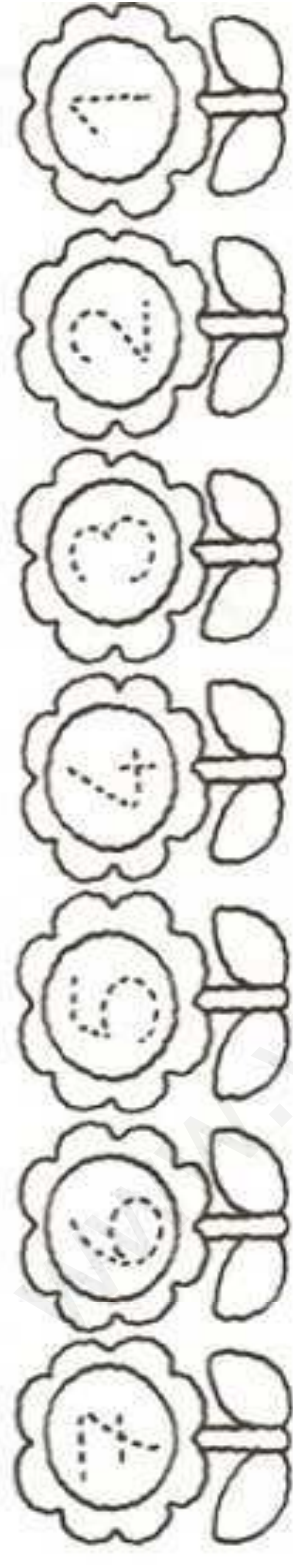
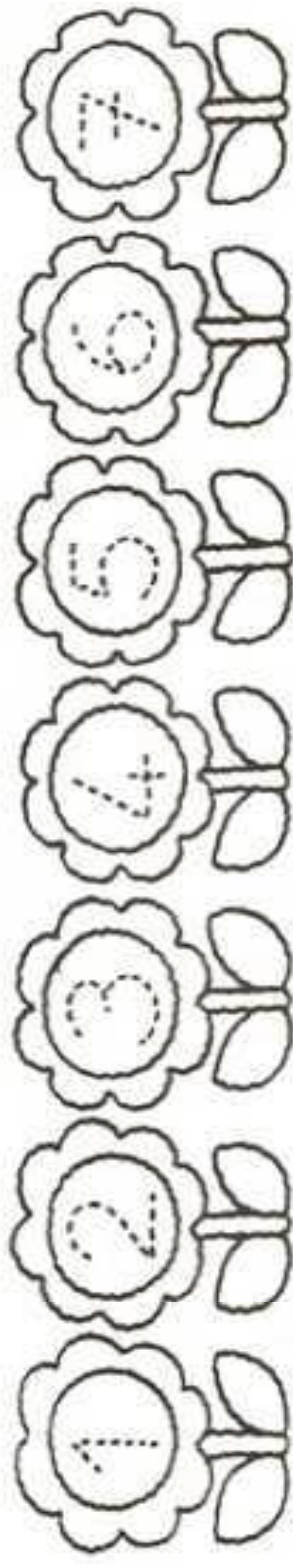

¡HOLA, SOY DOÑA ARAÑA! TENGO OCHO PATAS.
COLOREA LA ARAÑA Y CUENTA CUÁNTAS PATAS TIENE. SON

59

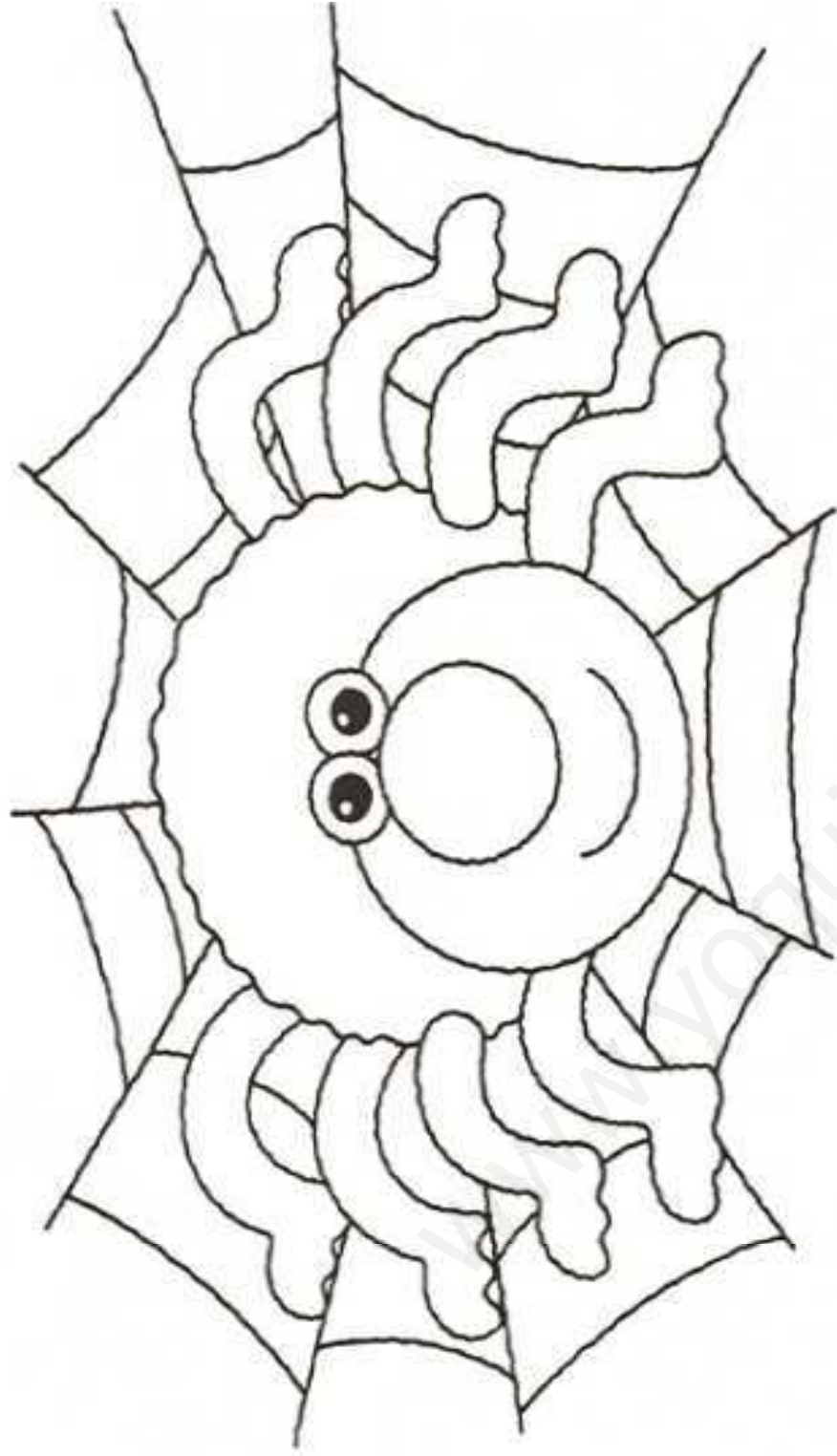

COLOREA TANTOS ZAPATOS COMO NECESITA LA ARAÑA.

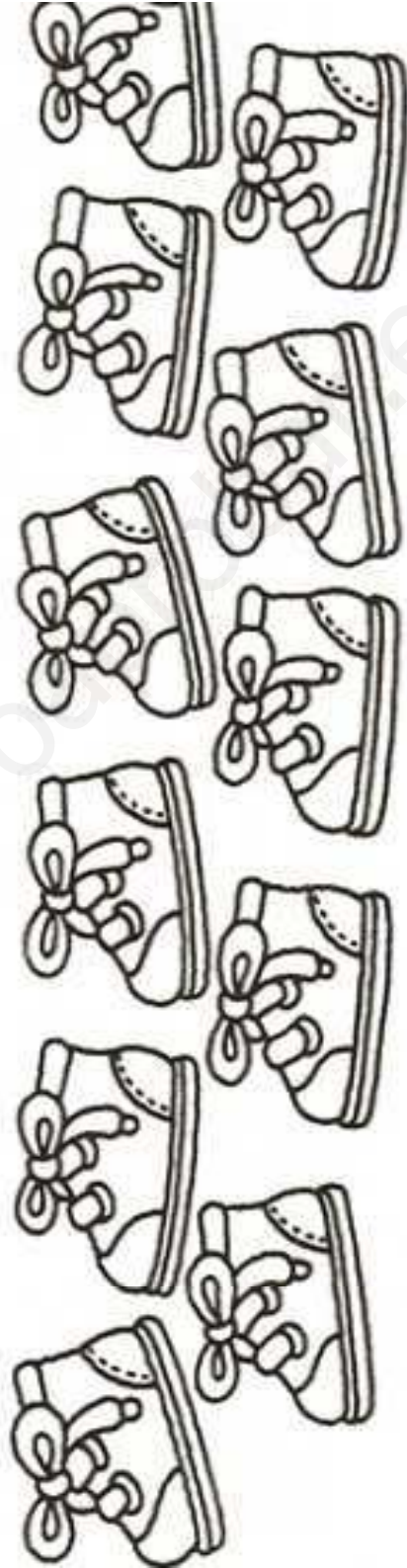

COLOREA LA CAMISA QUE SE PUEDE PONER DOÑA ARAÑA.

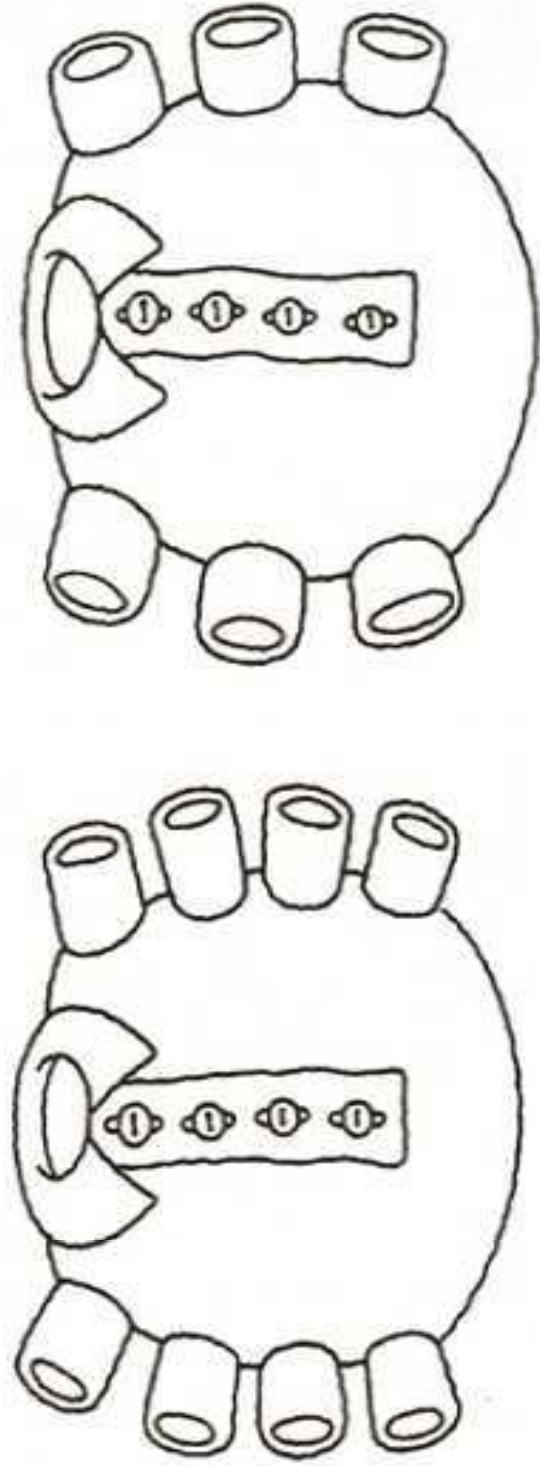

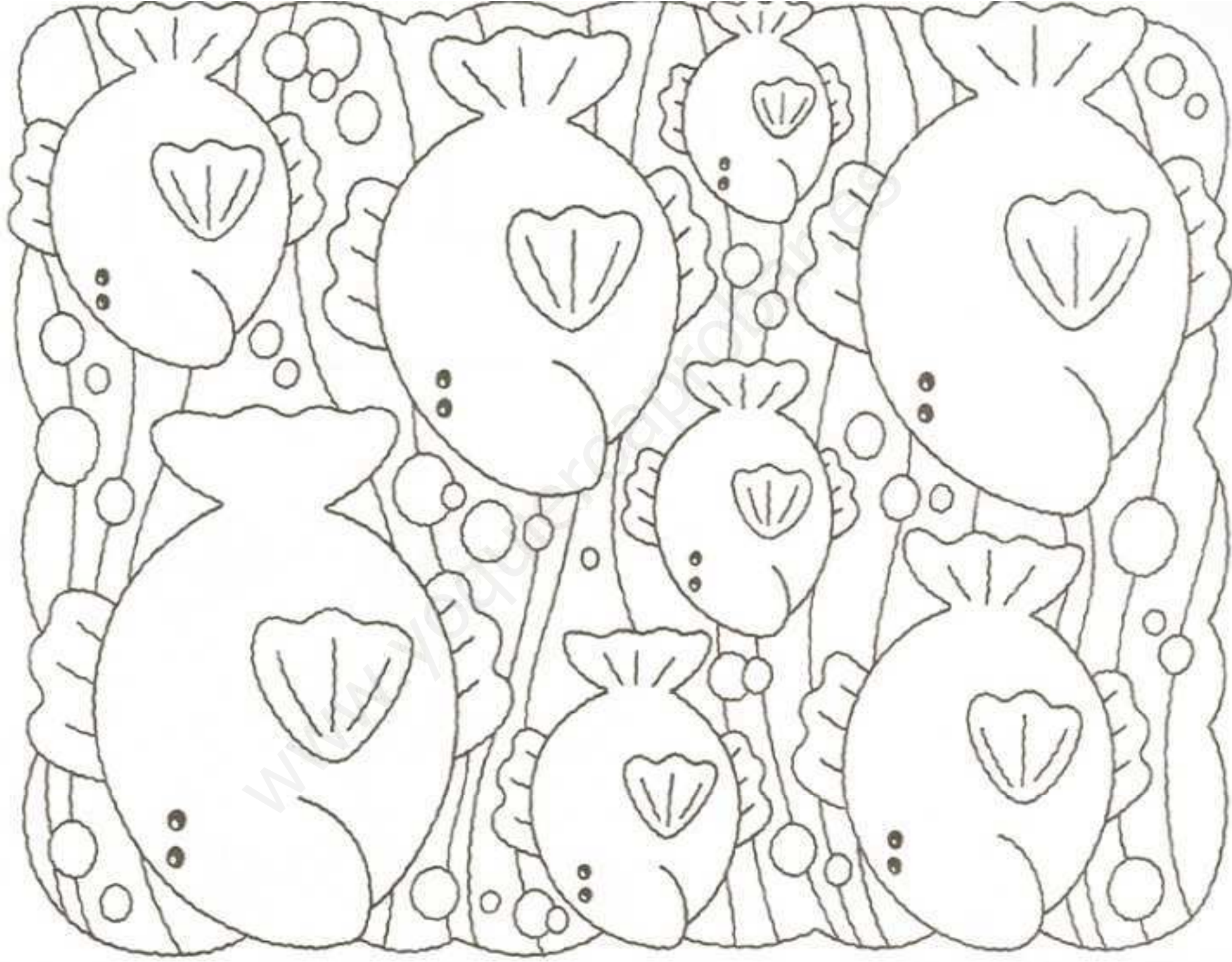

ENUMERA CADA PEZ DEL MENOR AL MAYOR.

¿CUÁNTOS PECES HAY?

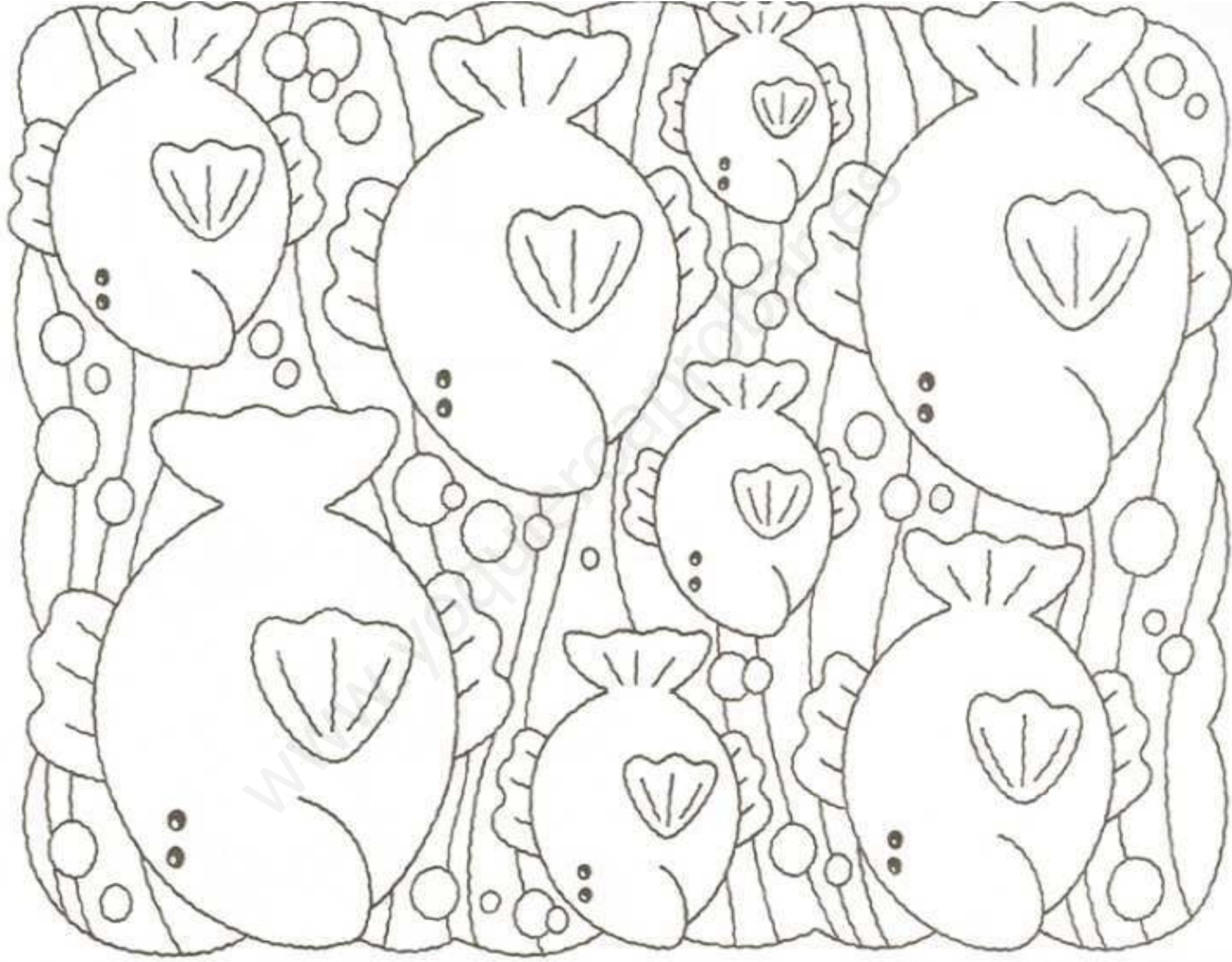

ENUMERA CADA PEZ DEL MENOR AL MAYOR.

¿CUÁNTOS PECES HAY?

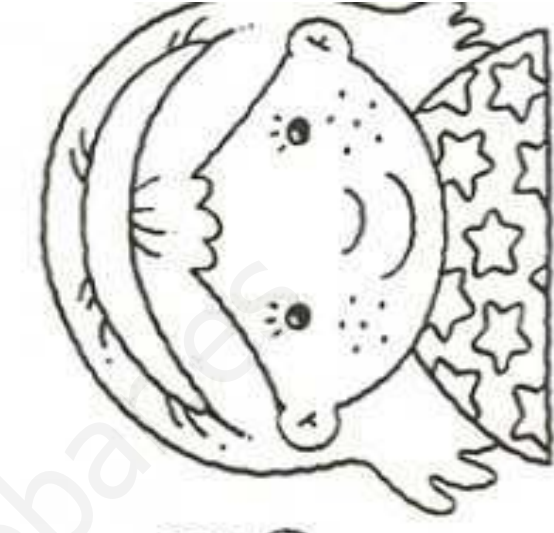
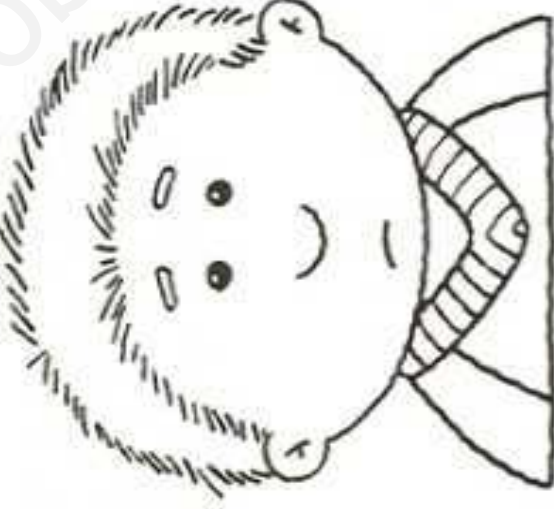
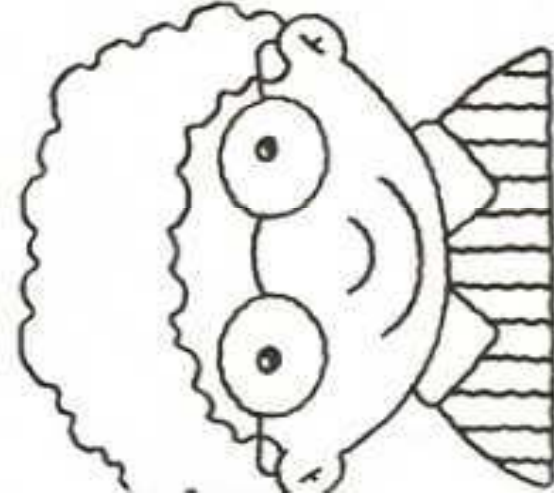
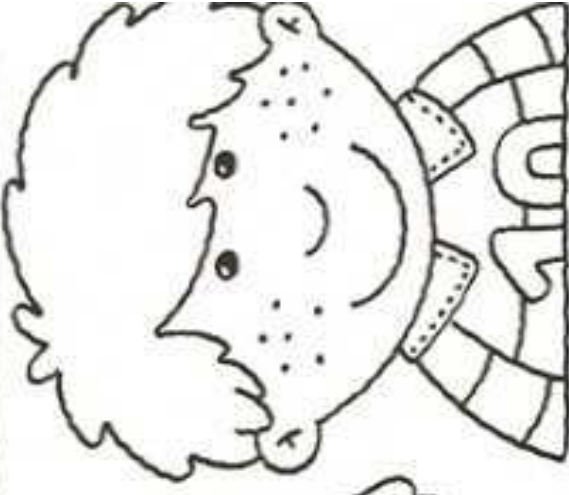
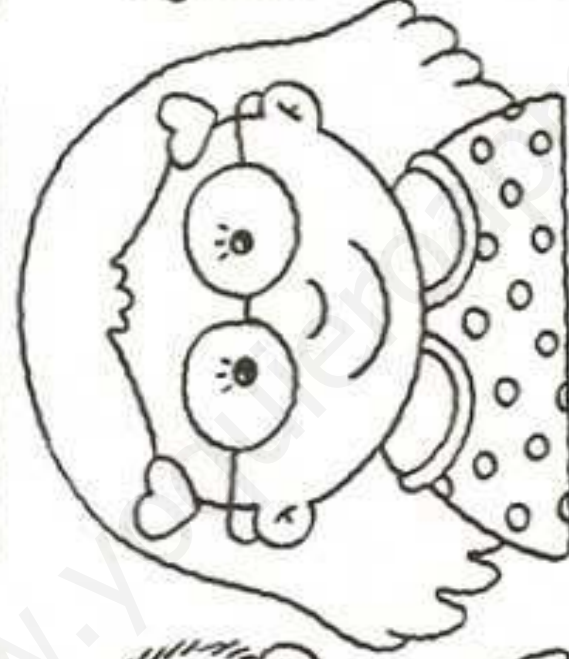
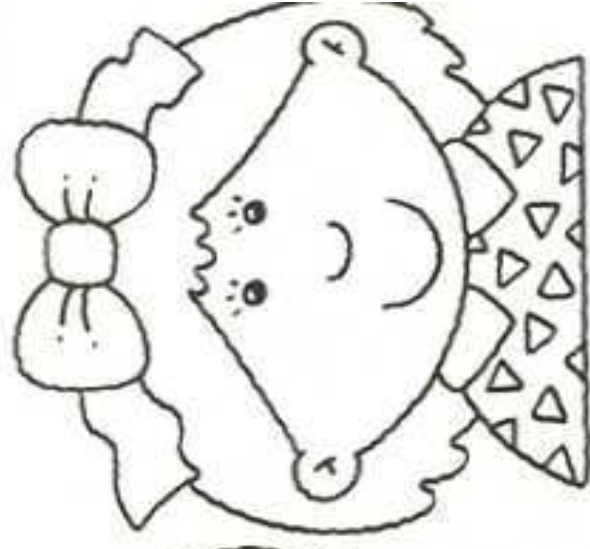
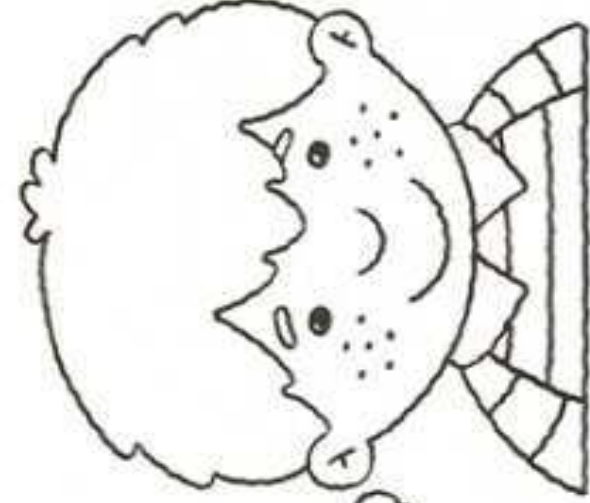
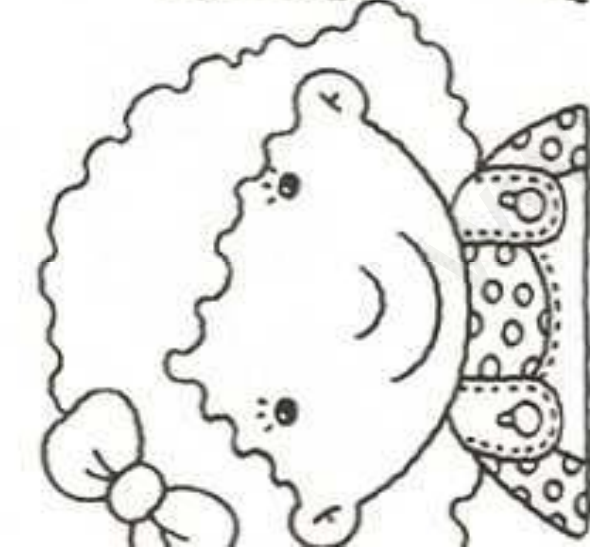

¿CUÁNTOS CHICOS HAY?

• ¿CUÁNTOS SON PECOSOS?

¿CUÁNTOS VARONES?

• ¿CUÁNTOS USAN ANTEOJOS?

¿CUÁNTAS MUJERES?

• ¿CUÁNTOS ESTÁN TRISTES?

¿QUE BUSCA ENCUENTRA!

COLOREA DE ROJO TODOS LOS NÚMEROS 9.
JUEGO COLOREA DE AZUL LOS NÚMEROS 6.

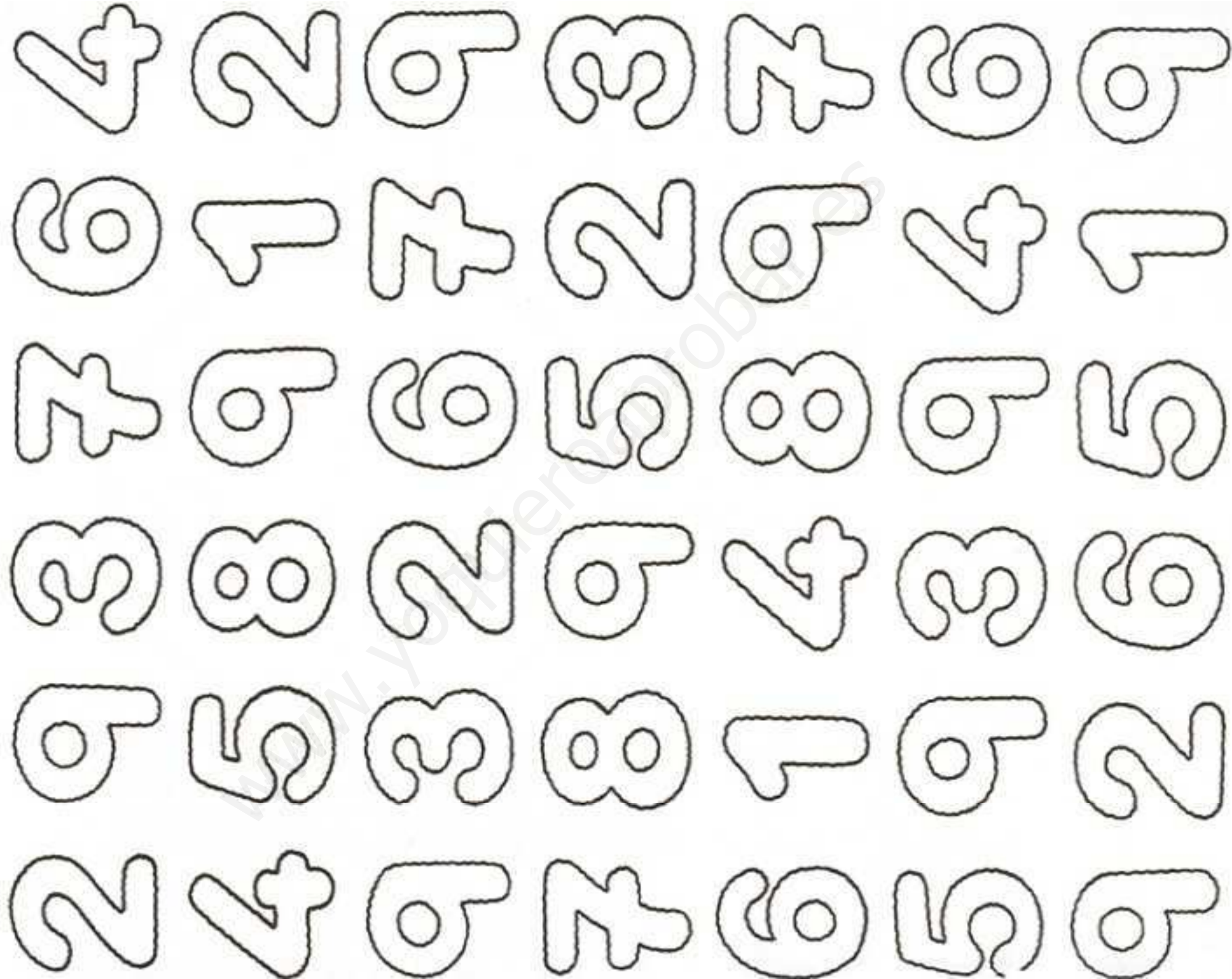

HOLA! AHORA QUE SABES CONTAR HASTA DIEZ, ¿ME AYUDAS?
 ESCRIBE EL NÚMERO CORRESPONDIENTE EN CADA CASILLERO.
 COLOREA LA IMAGEN.

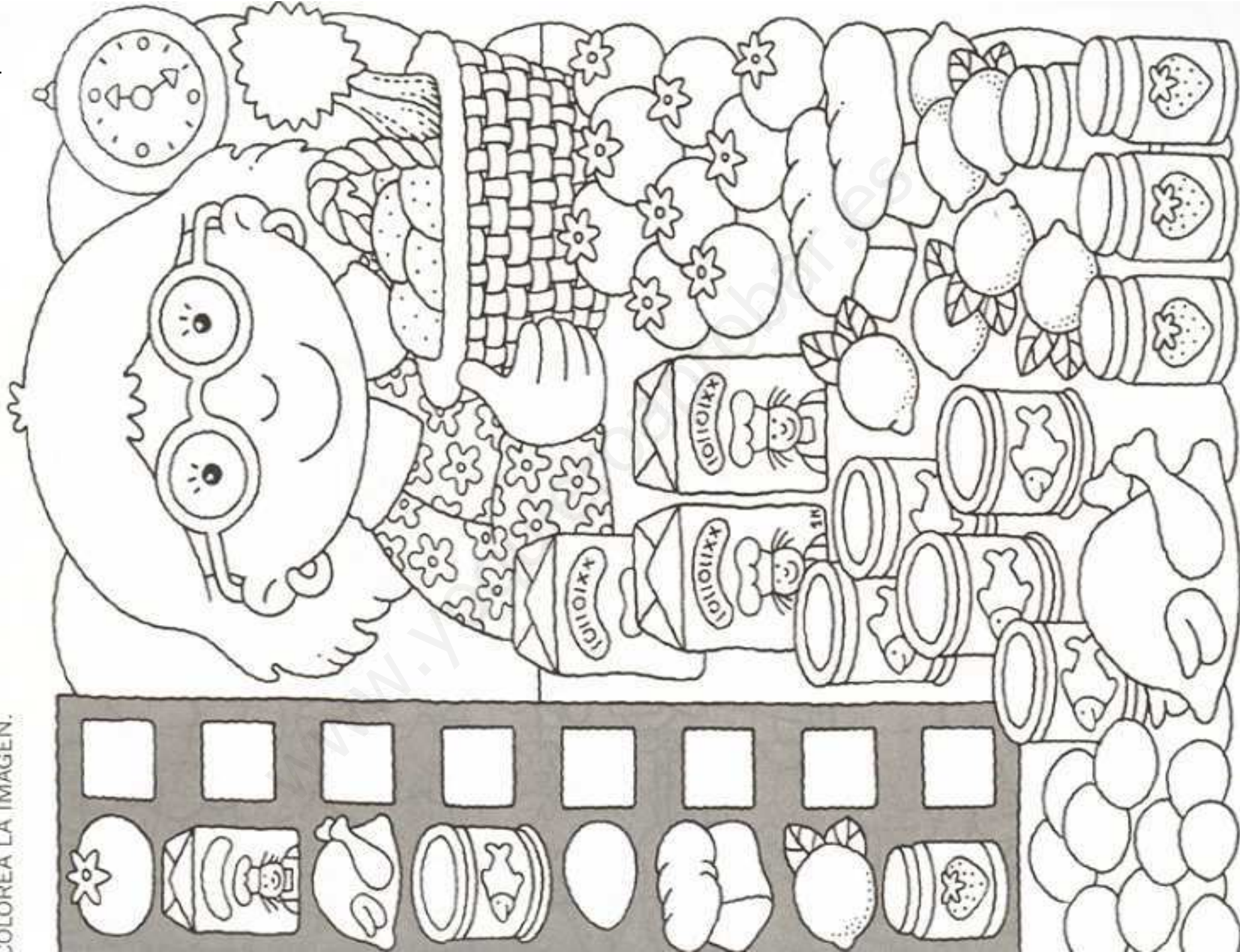

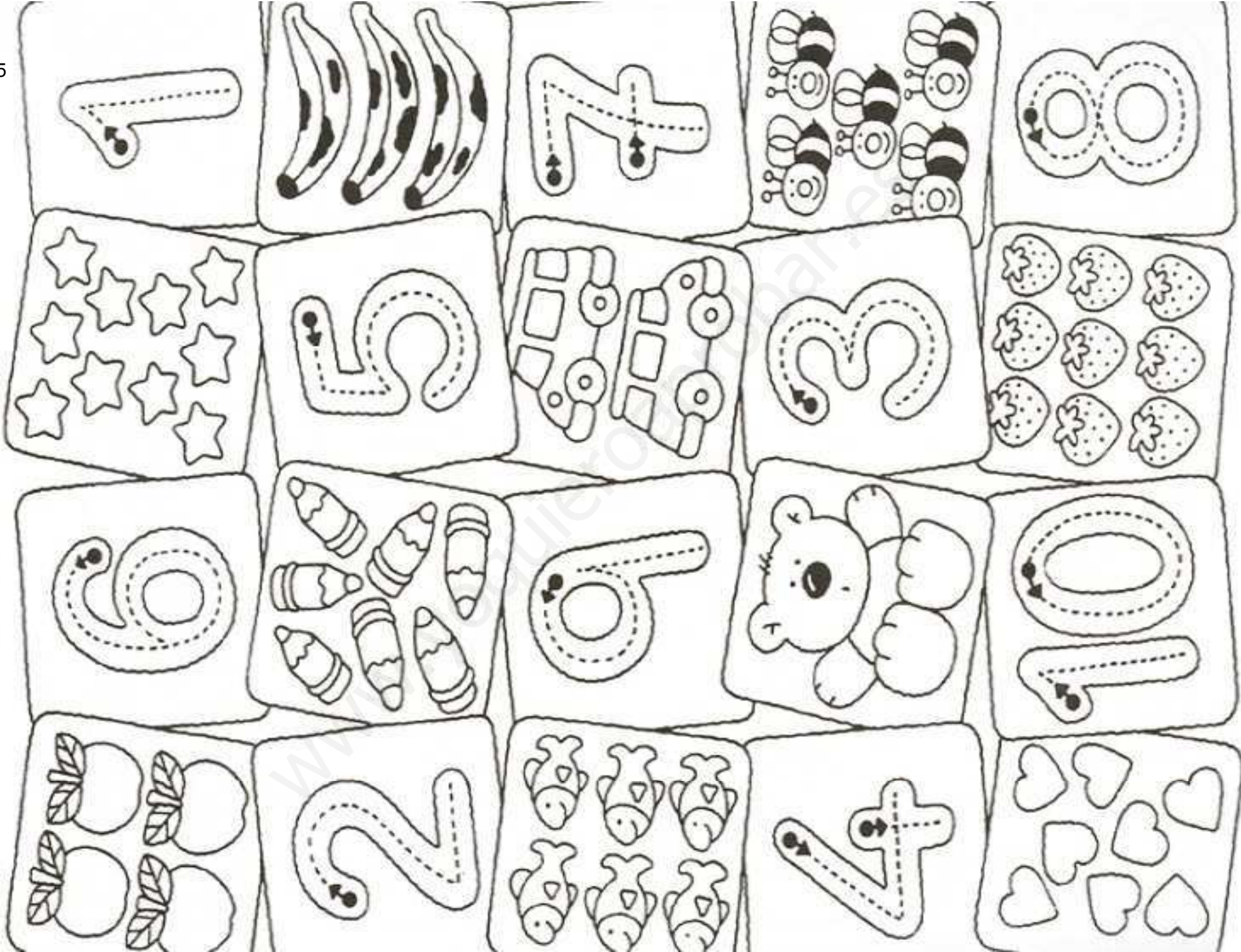

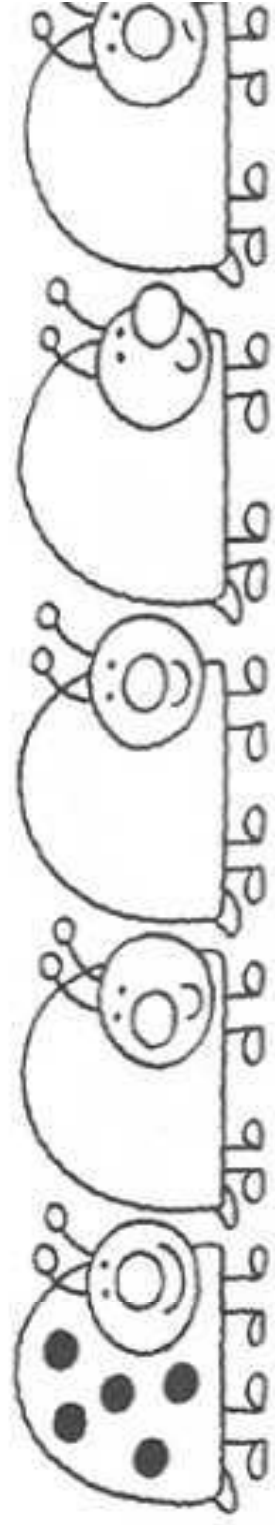

5

□

□

□

□

□

□

□

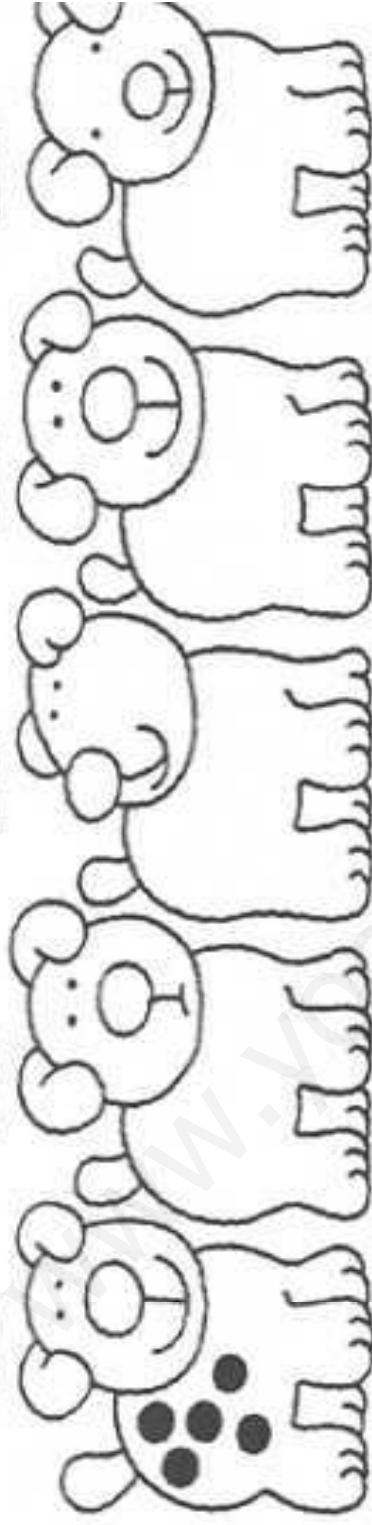

5

□

□

□

□

□

□

□

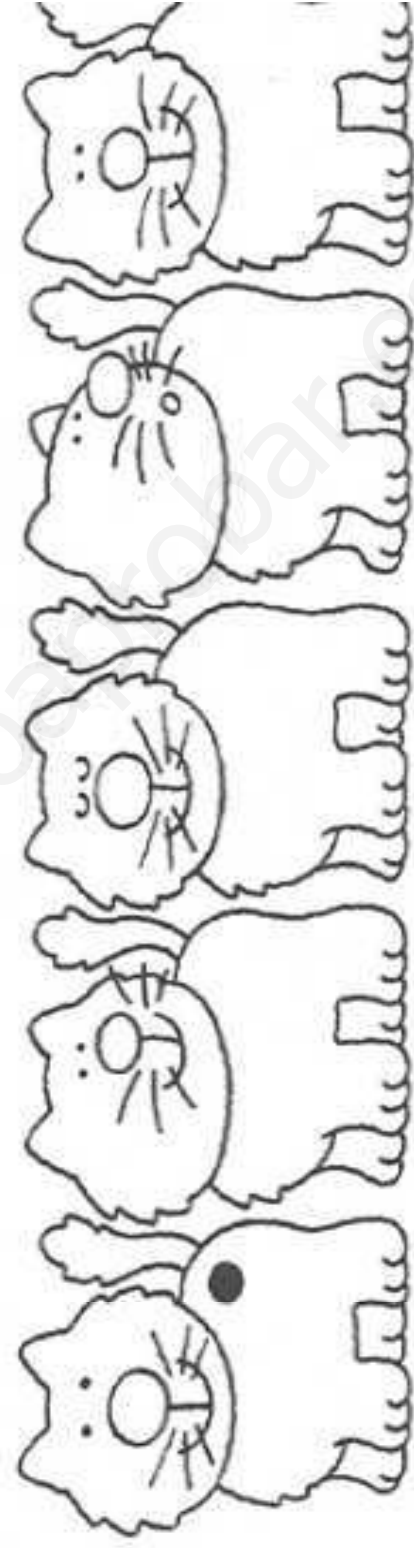

1

□

□

□

□

□

□

□

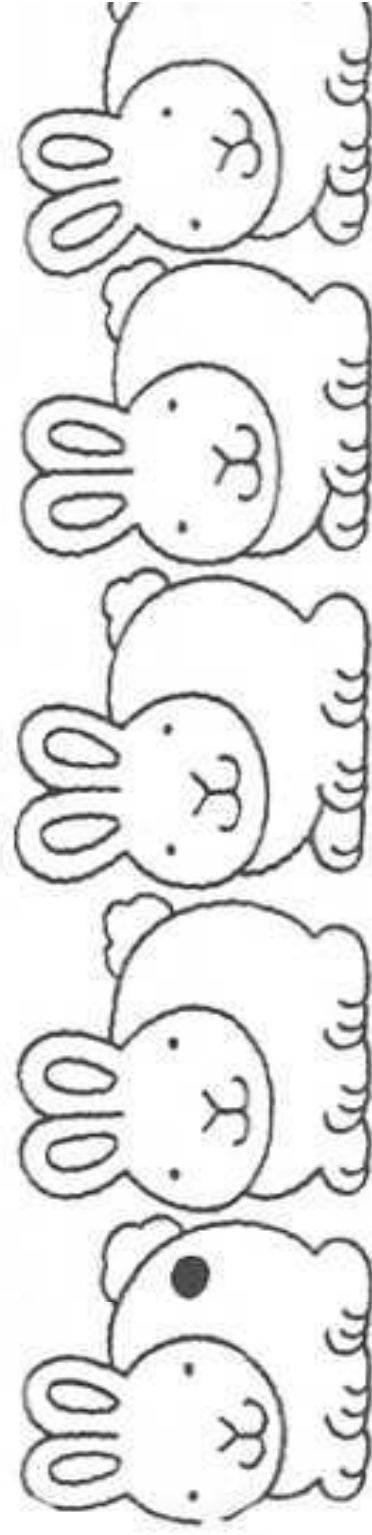

1

□

□

□

□

□

□

□

¿CUÁNTOS LUNARES TIENE CADA MARIQUITA? ESCRIBE EL NÚMERO DEBAJO DE CADA UNA.

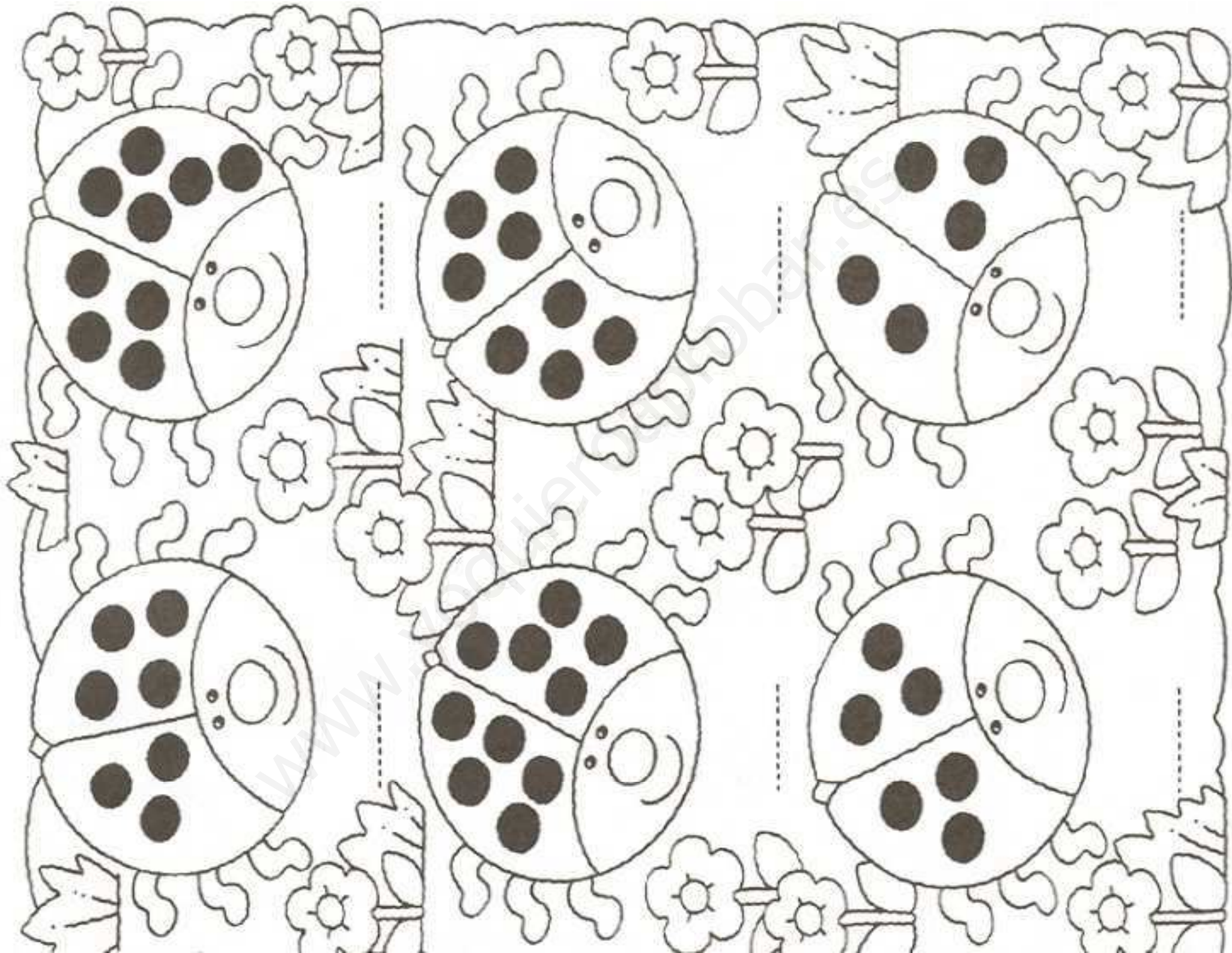

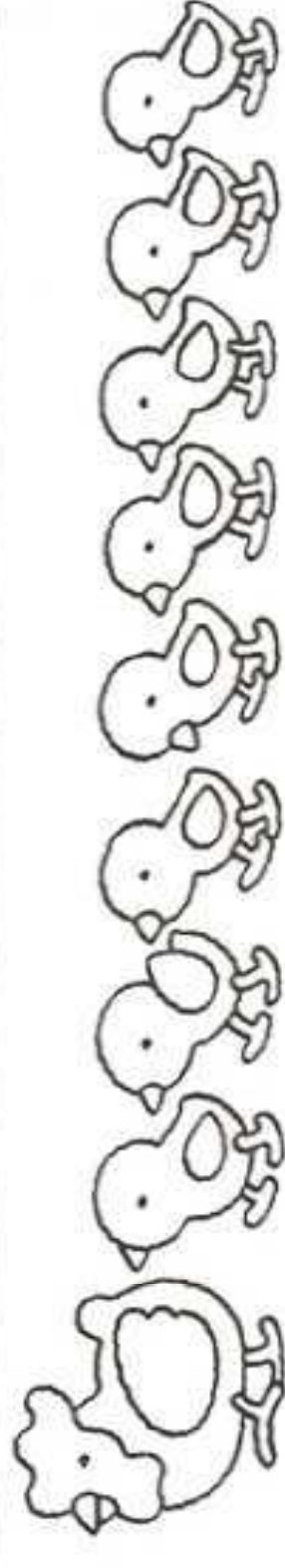
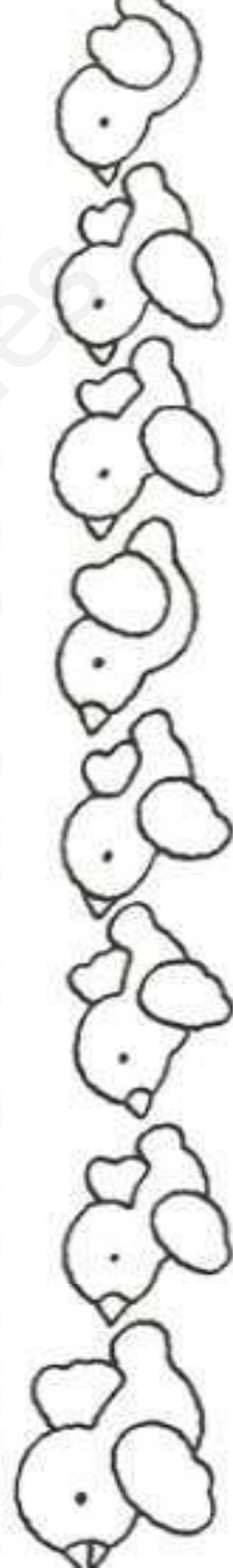
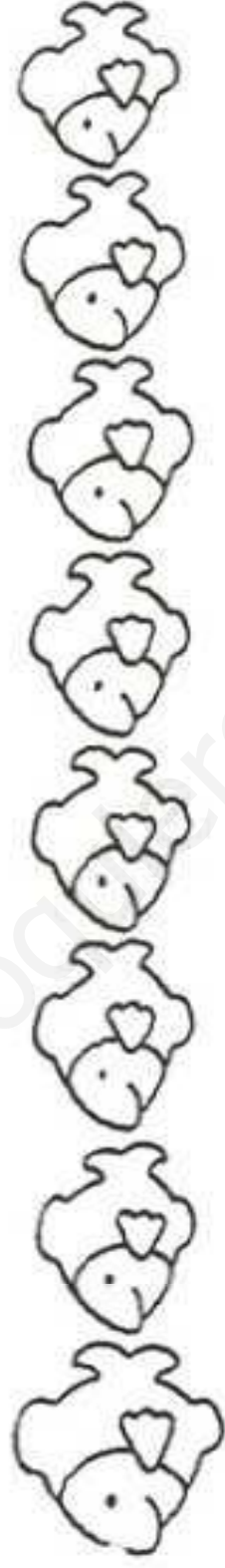
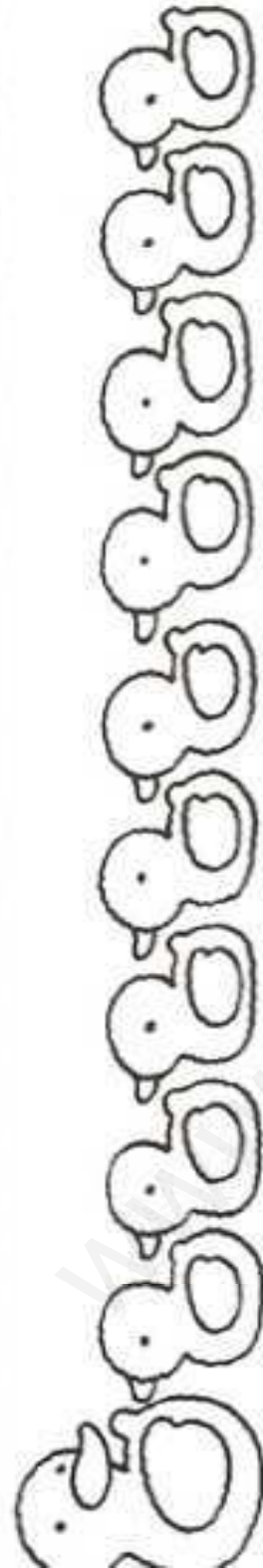

COLOREA LOS NÚMEROS EN LA DIRECCIÓN CORRECTA.

DECORA LAS MARIPOSAS CON TANTOS LUNARES COMO INDICA EL NÚMERO QUE EST

A SU LADO.

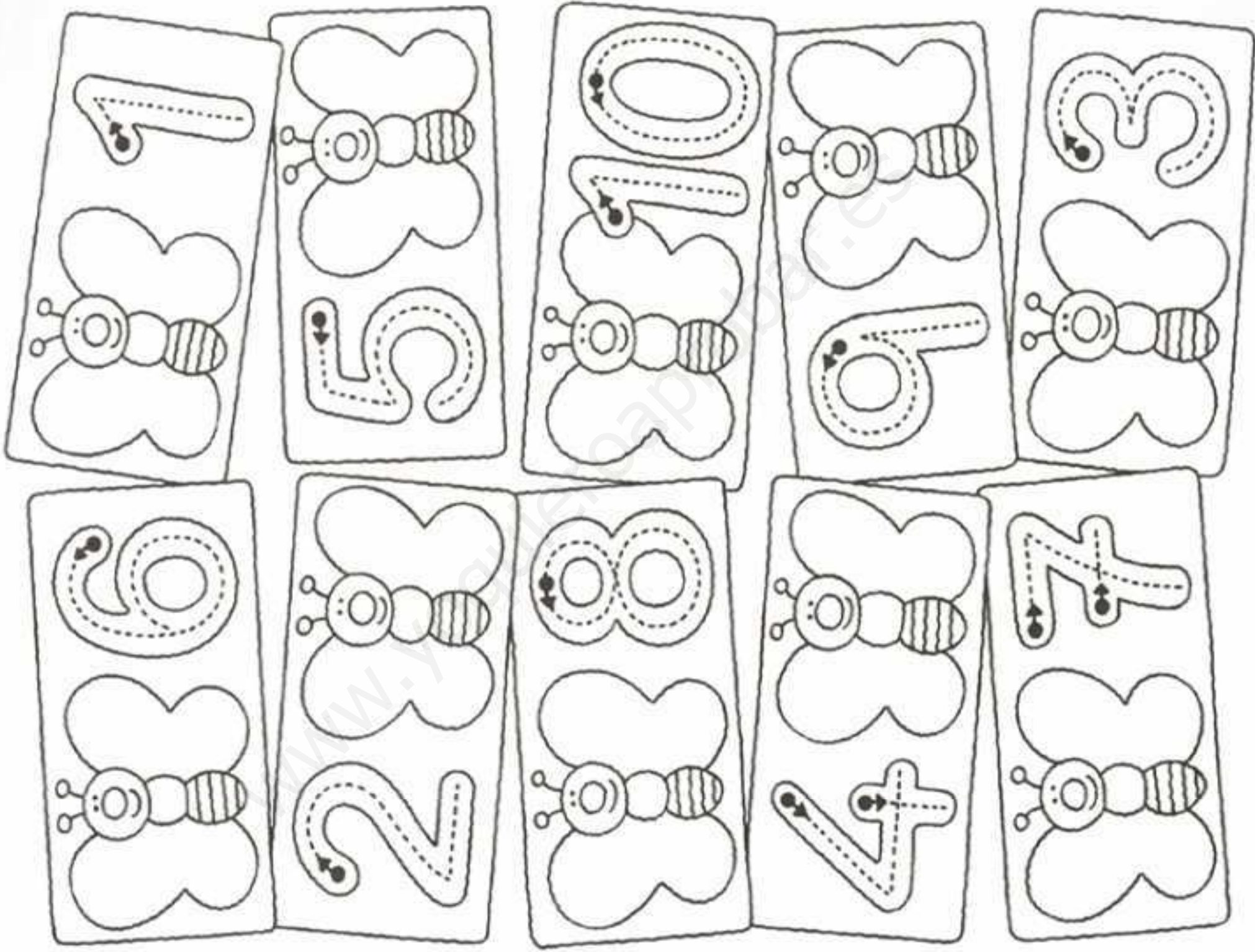

MÁS USOS DE LOS NÚMEROS!
ANÍMATE A ESCRIBIRLOS EN CADA OBJETO.

72

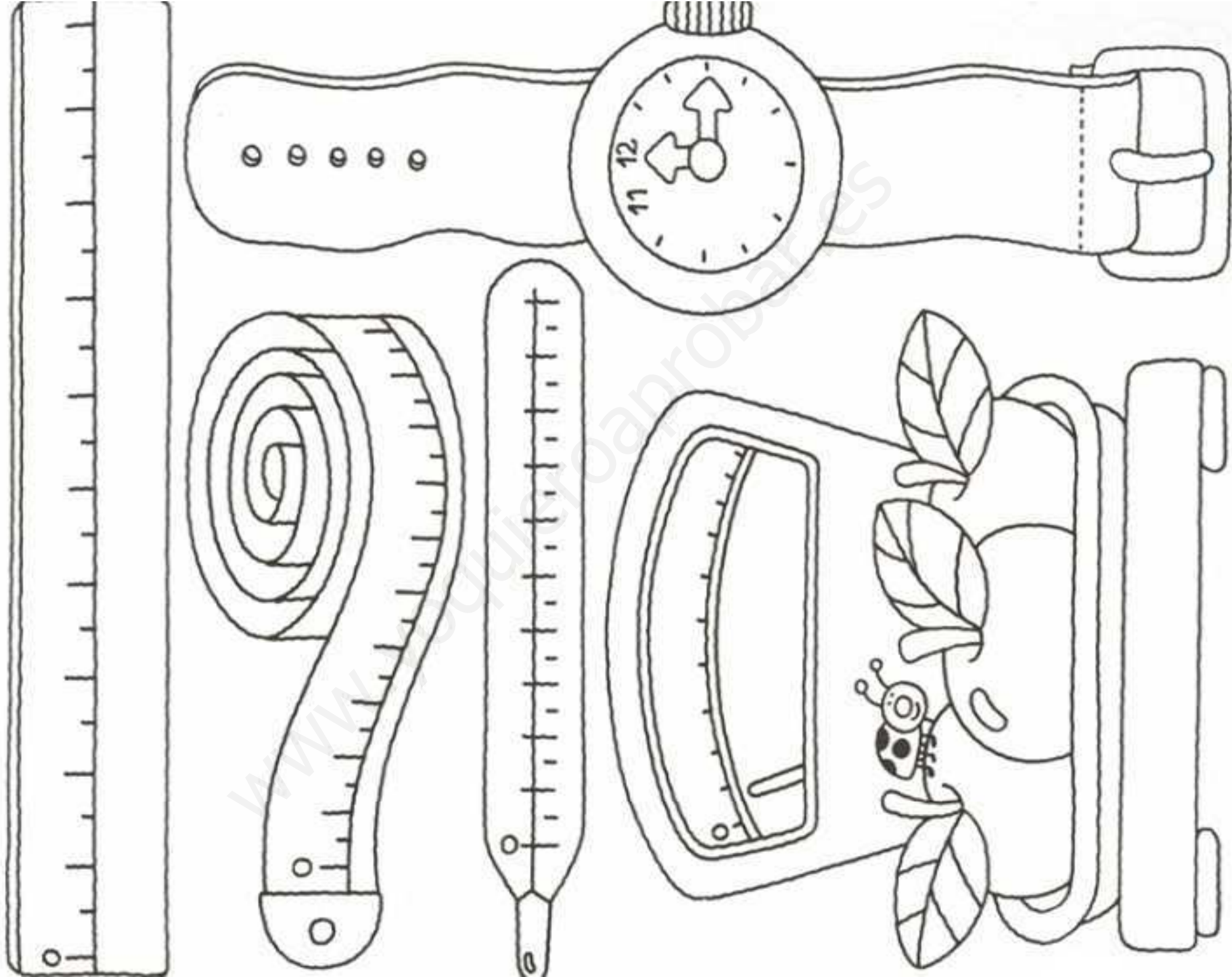

AVERIGUA Y ESCRIBE LOS NÚMEROS DE TELÉFONO DE ESTOS SERVIDORES PÚBLICOS.
IMITA EL SONIDO DE SUS SIRENAS.
COLOREA LAS IMÁGENES.

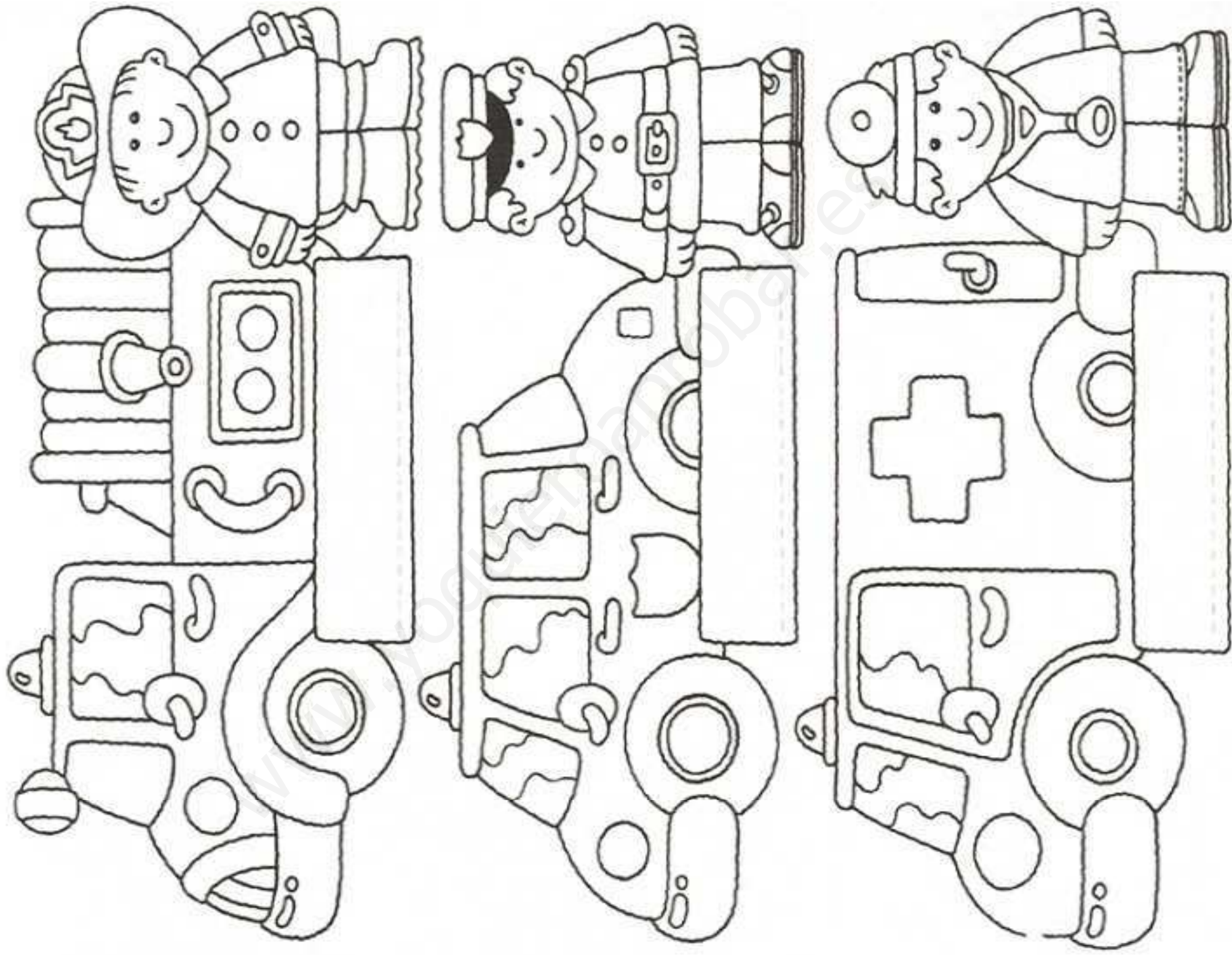

A BUSCAR! COLOREA, CUENTA Y COMPLETA CADA CASILLERO CON EL NÚMERO CORRESPONDIENTE.

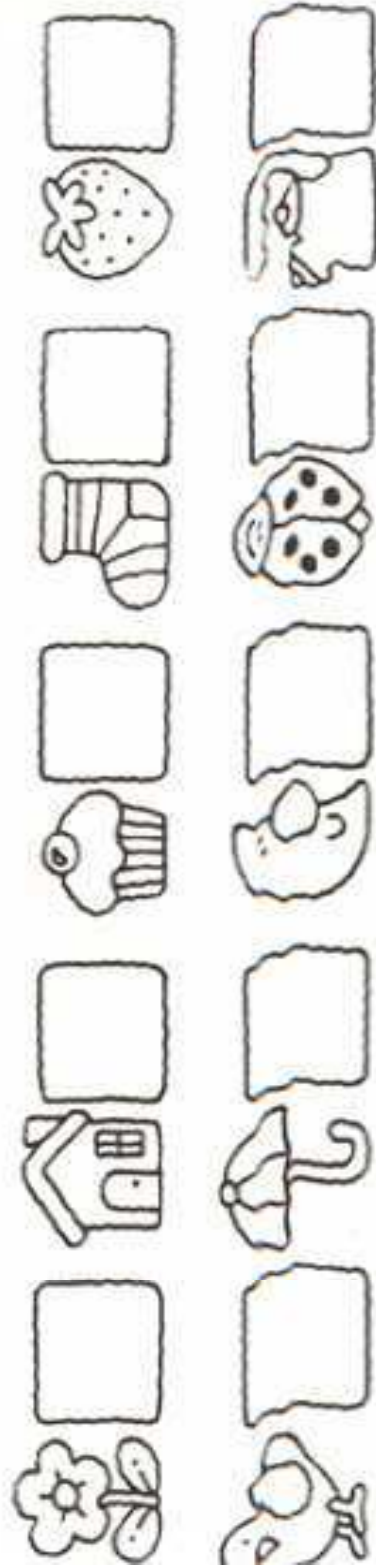
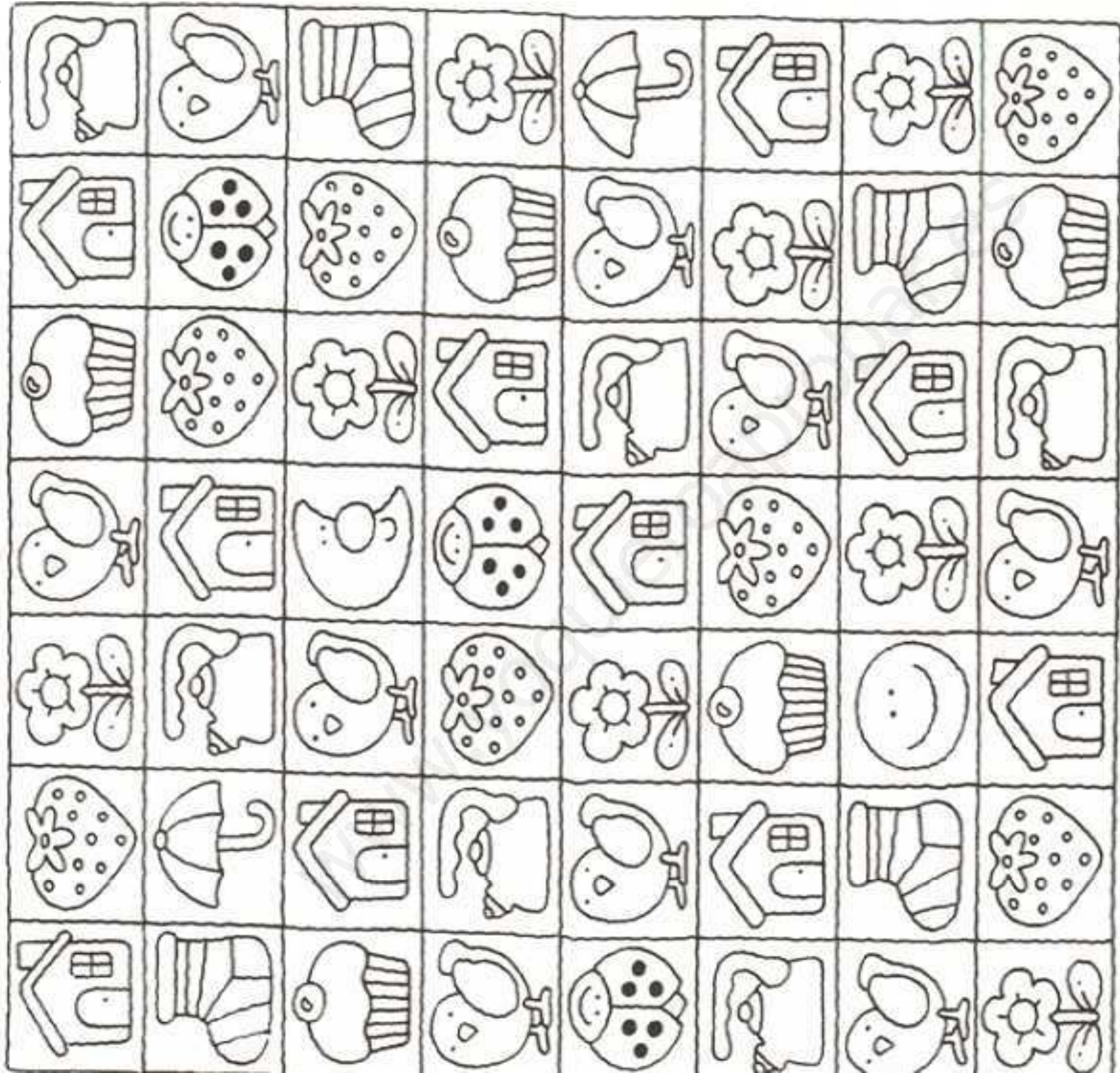

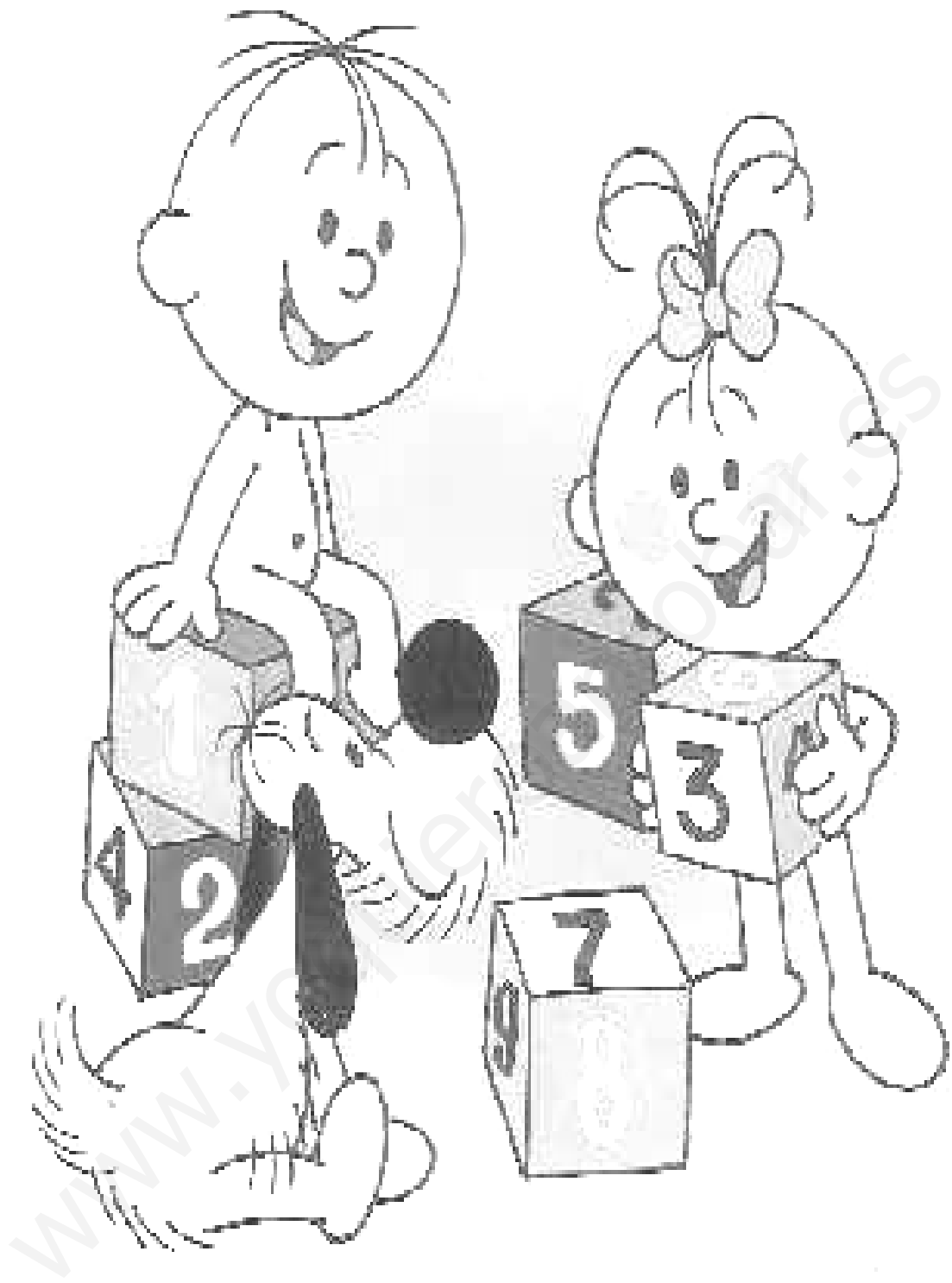

NÚMEROS

1

Libro 2. Números repaso

Colorea el número 1.

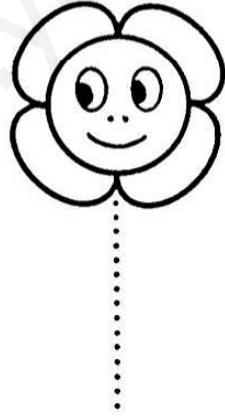
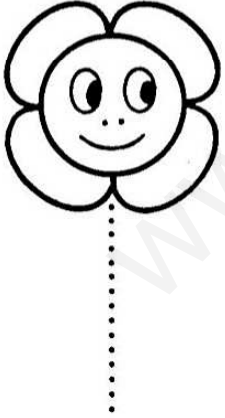
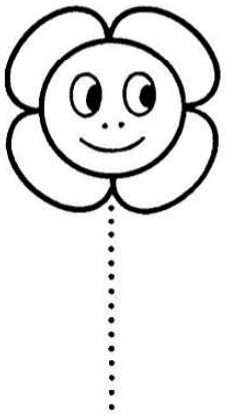
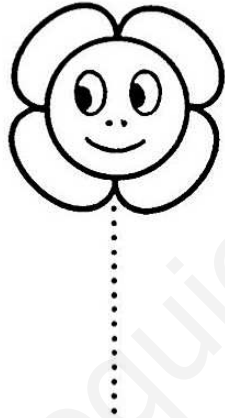
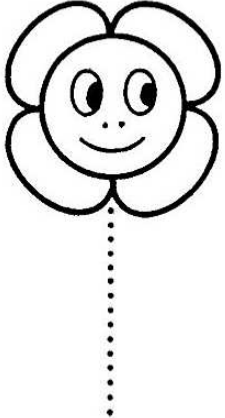
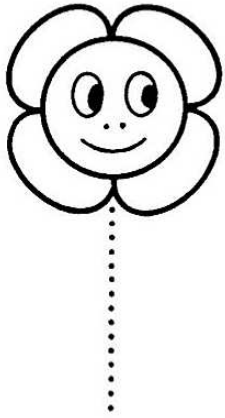
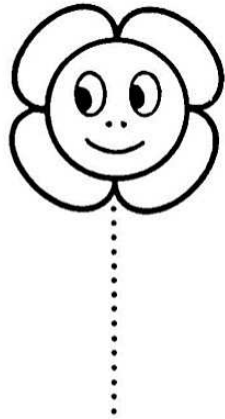
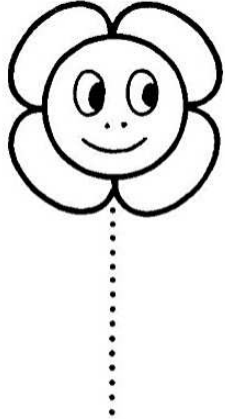
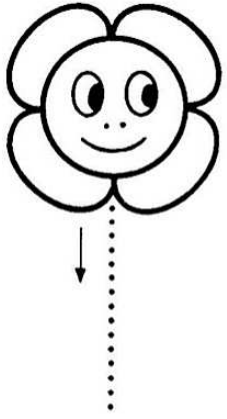

Sigue las líneas de puntos y colorea.

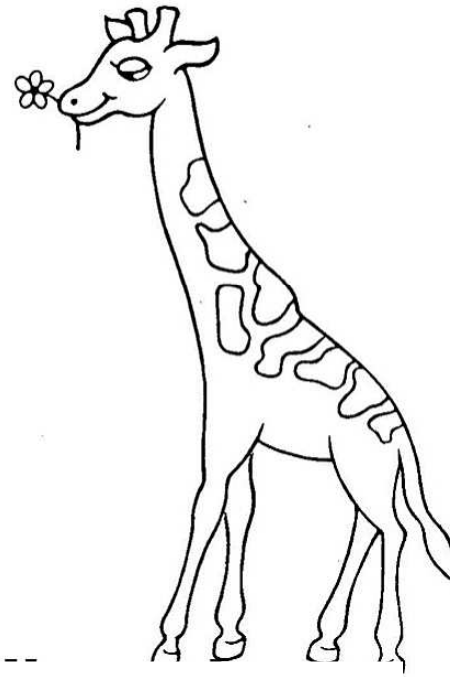
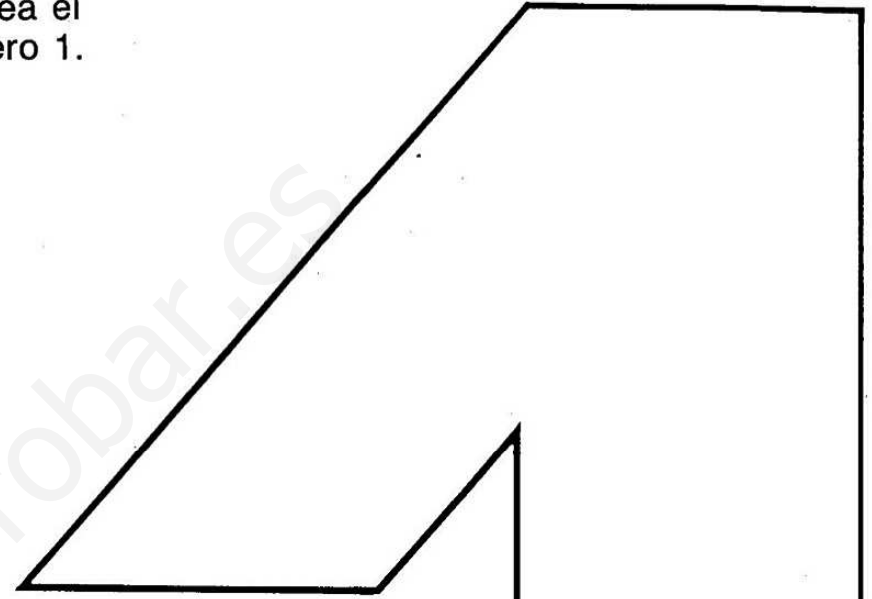

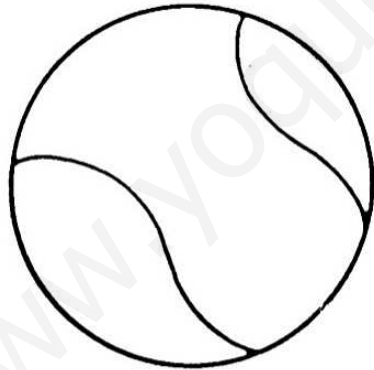
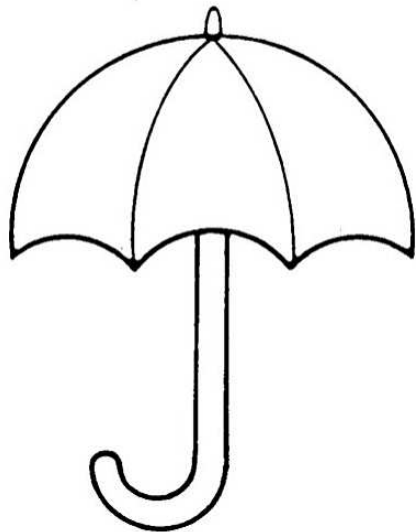
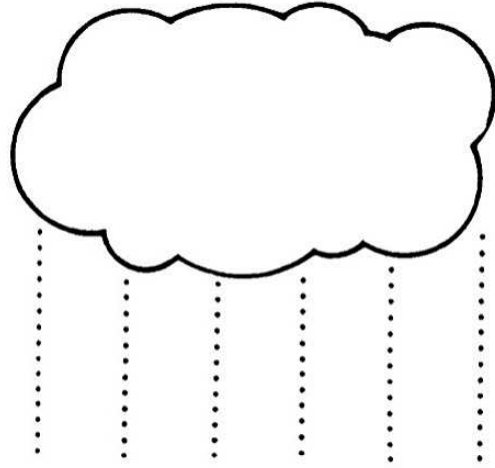
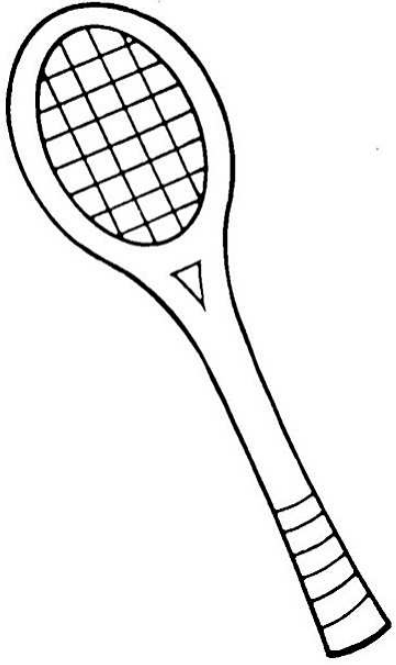

Une los dibujos que se correspondan y píntalos.

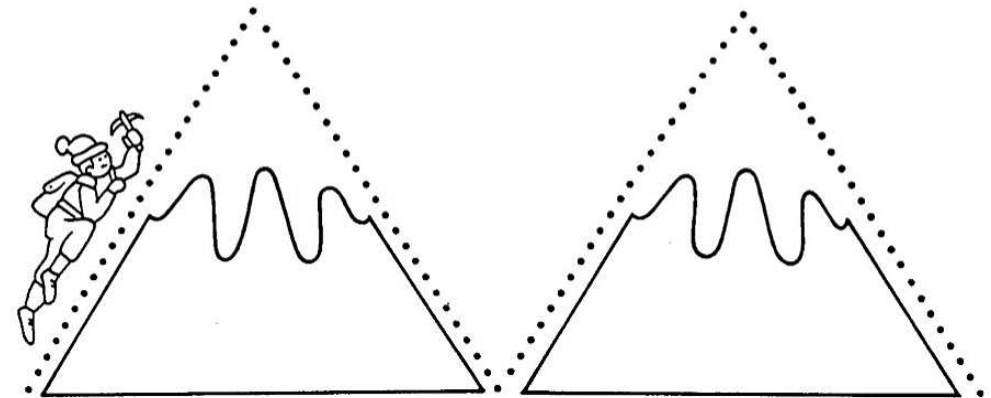
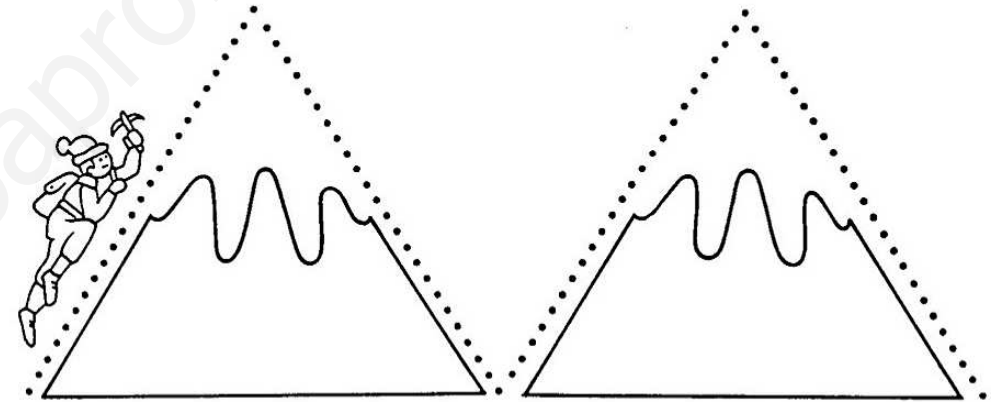
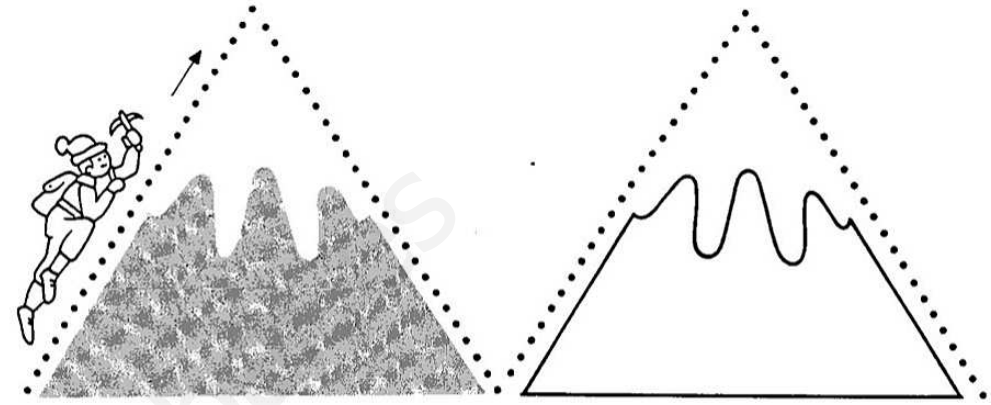

Sigue los puntos y colorea las montañas.

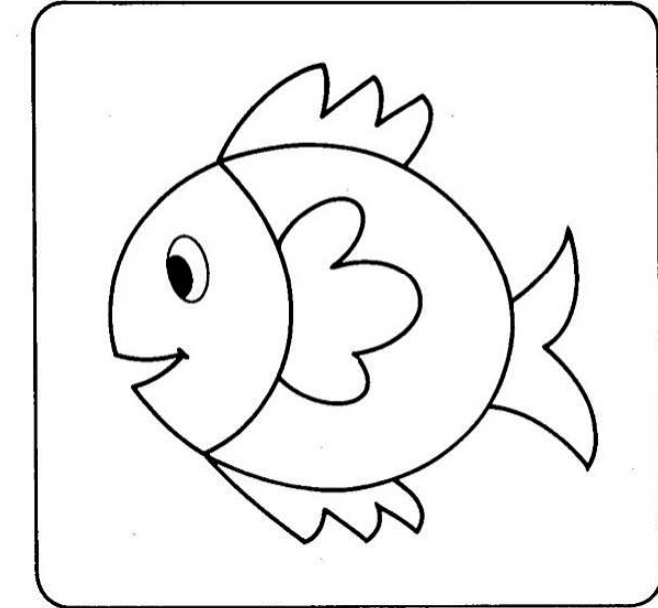
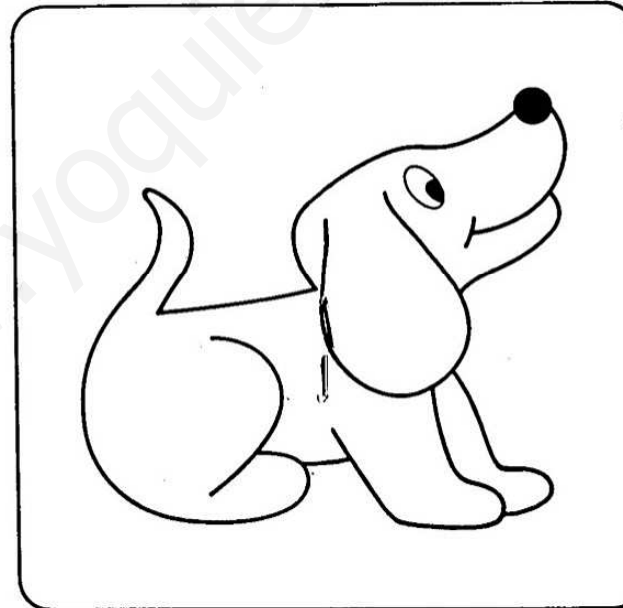
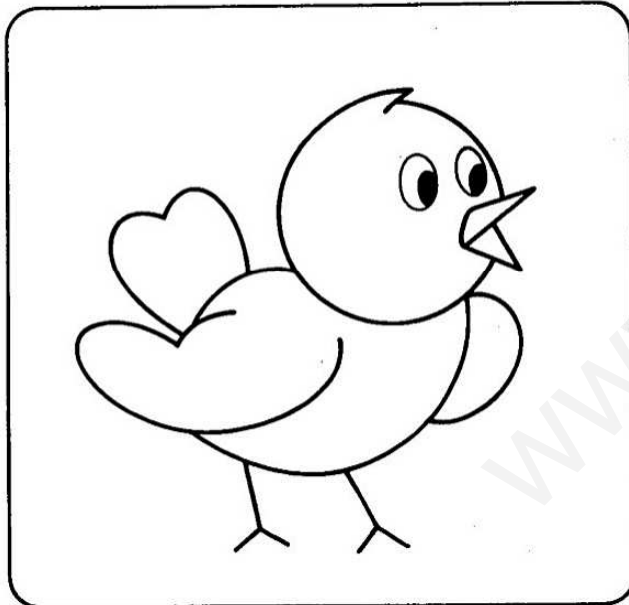
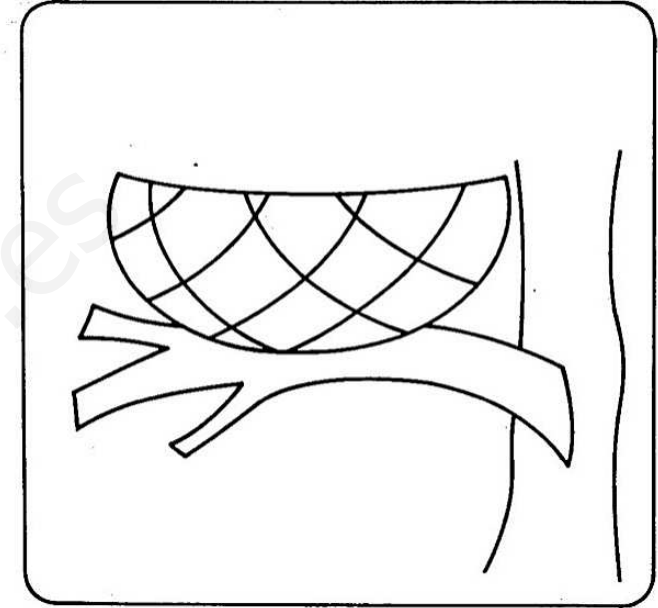
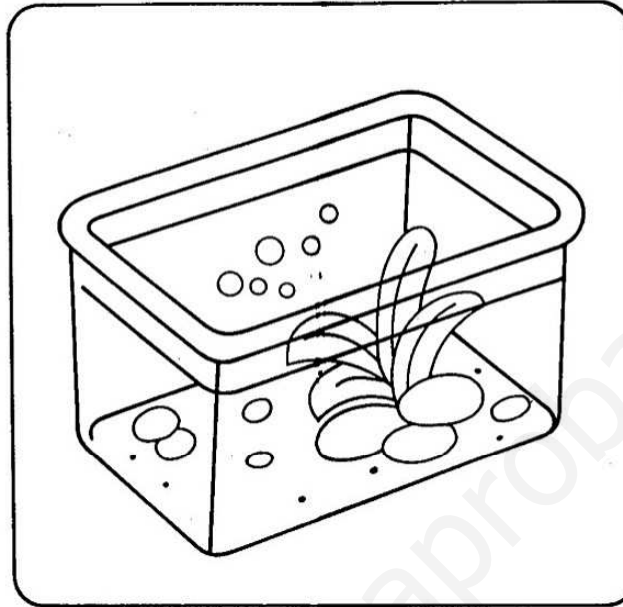
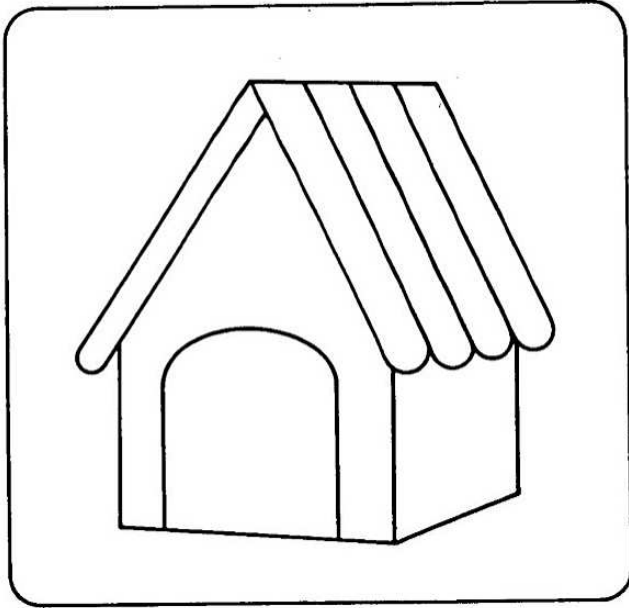

Une cada animalito con su vivienda y da color.

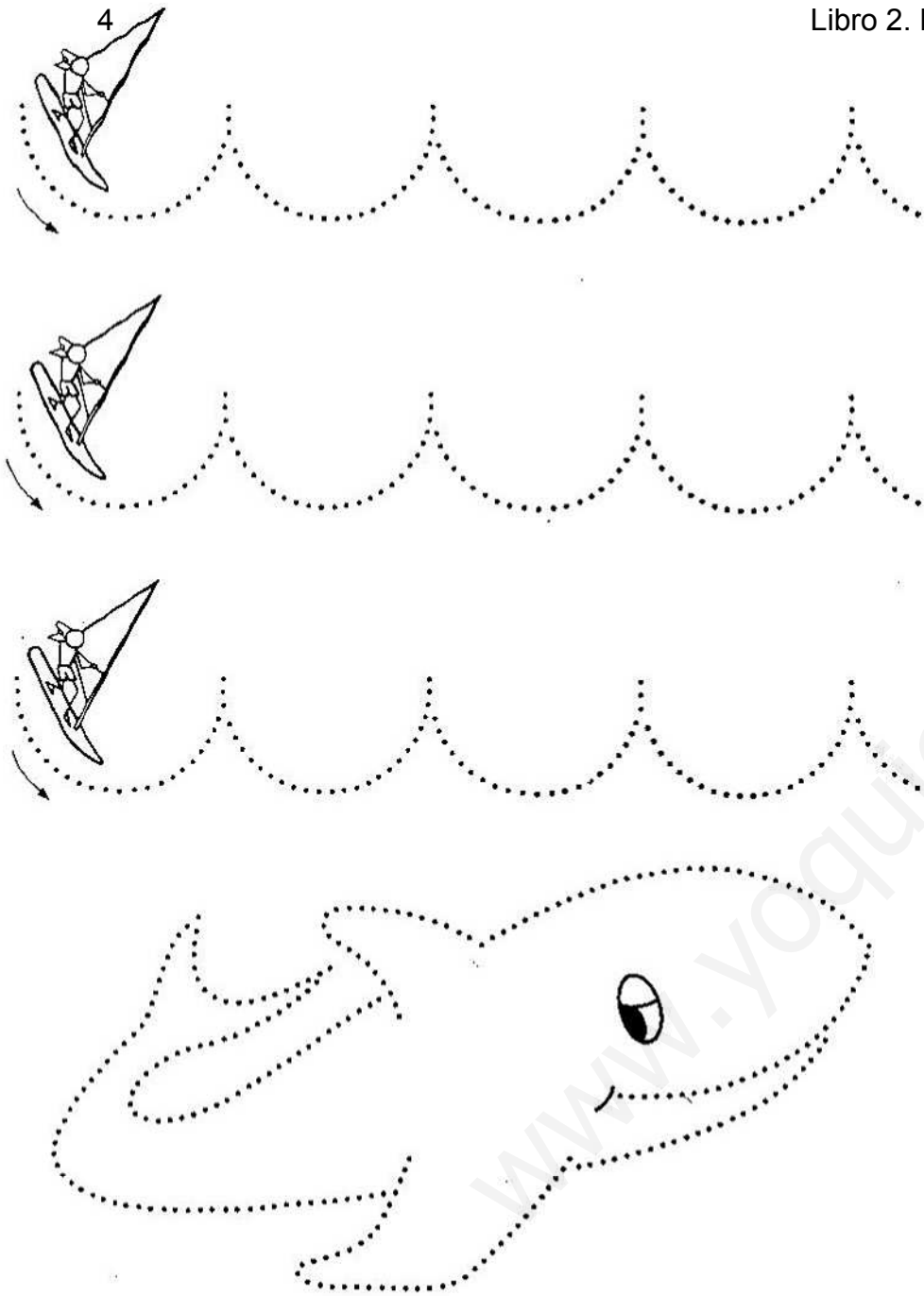

Repasa las líneas de puntos y colorea el tiburón.

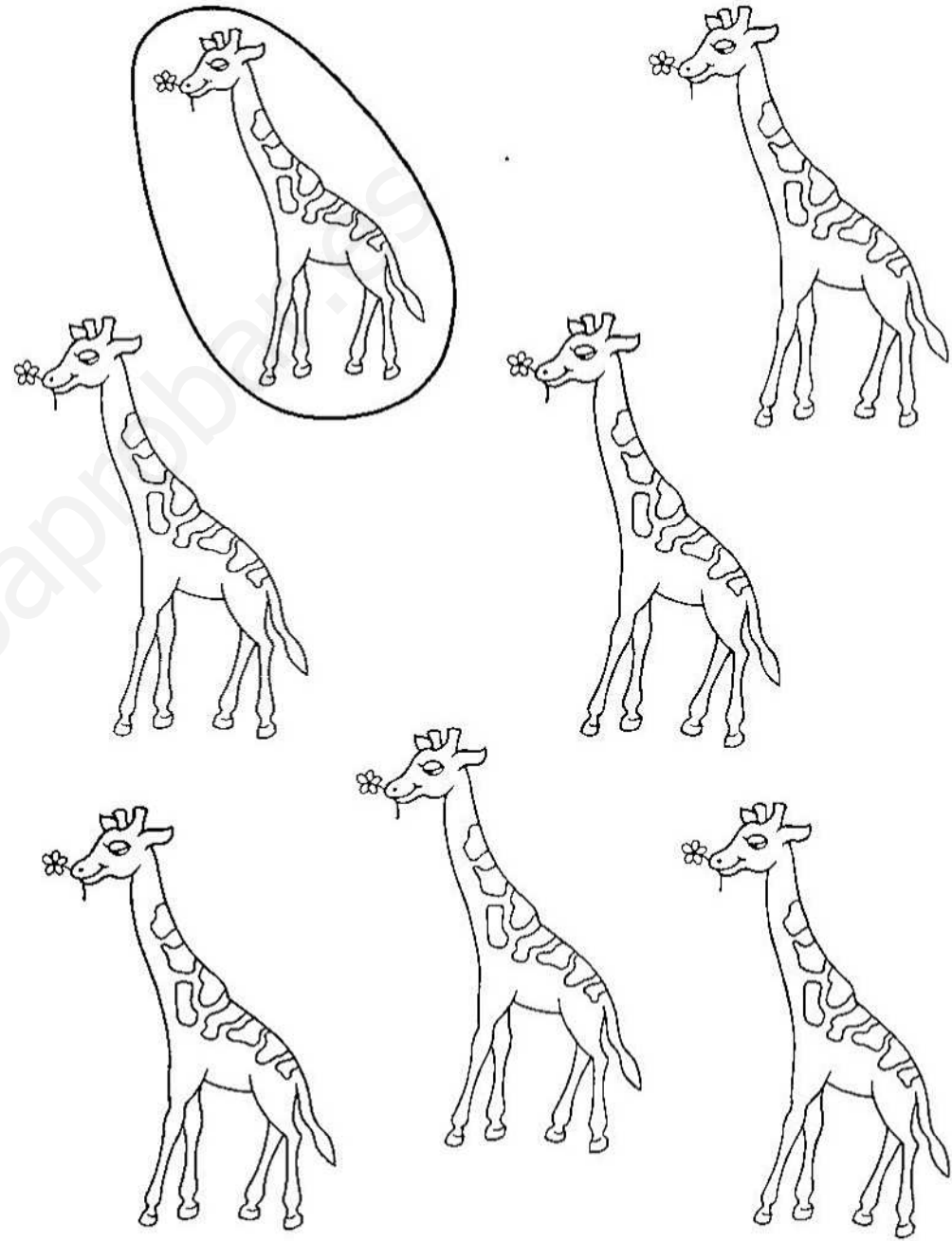

Rodea las jirafas de una en una como la muestra y píntalas.

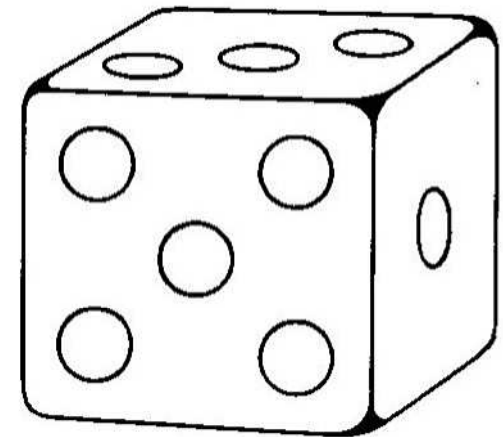
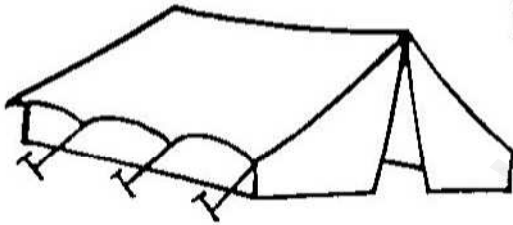
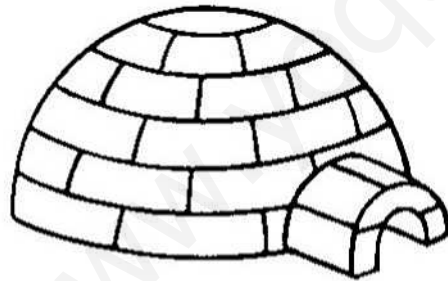
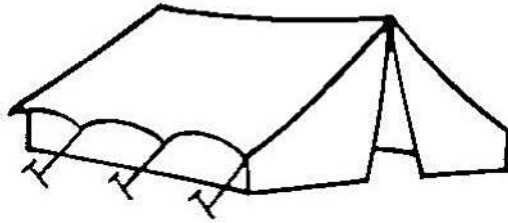
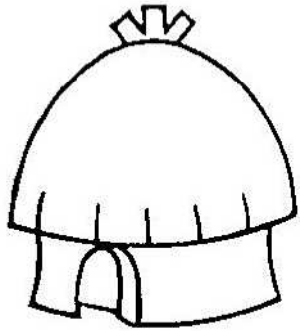
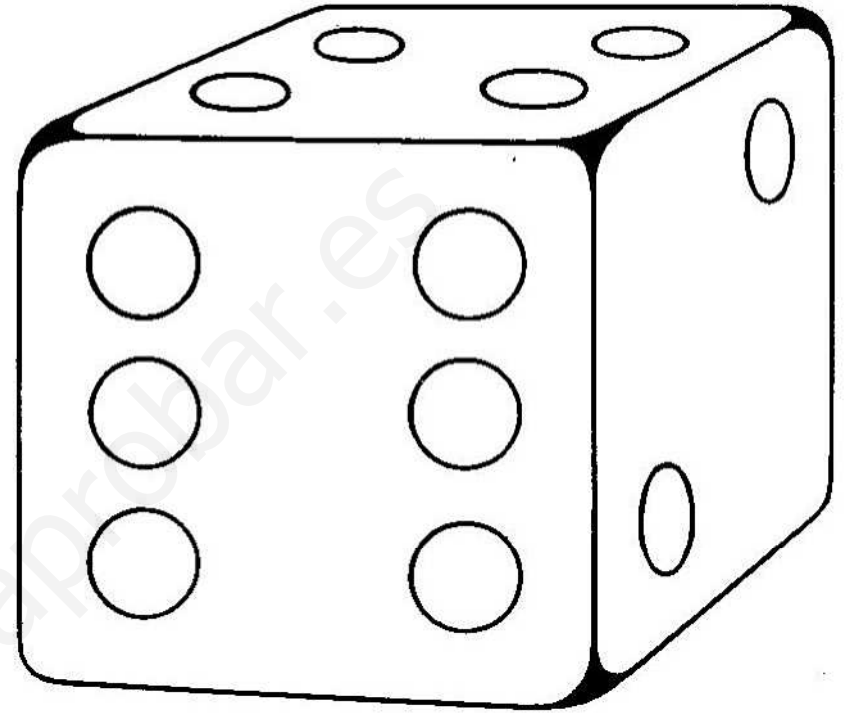
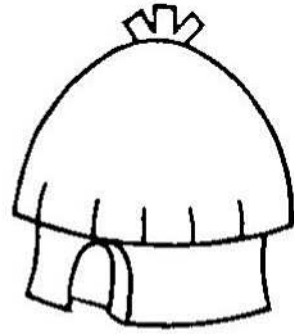
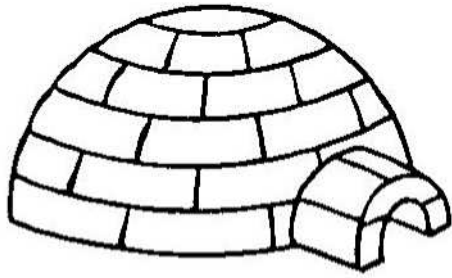

Une con una línea los dibujos que veas iguales y píntalos del mismo color.

Colorea el dado grande.

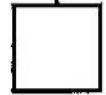
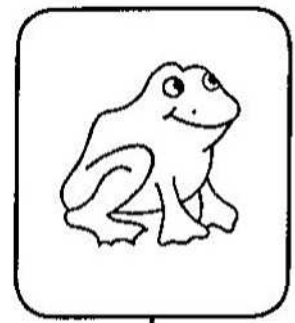
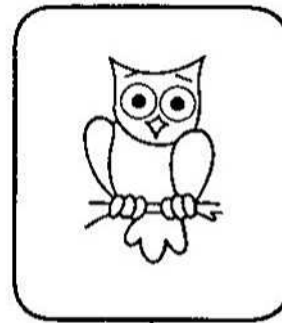
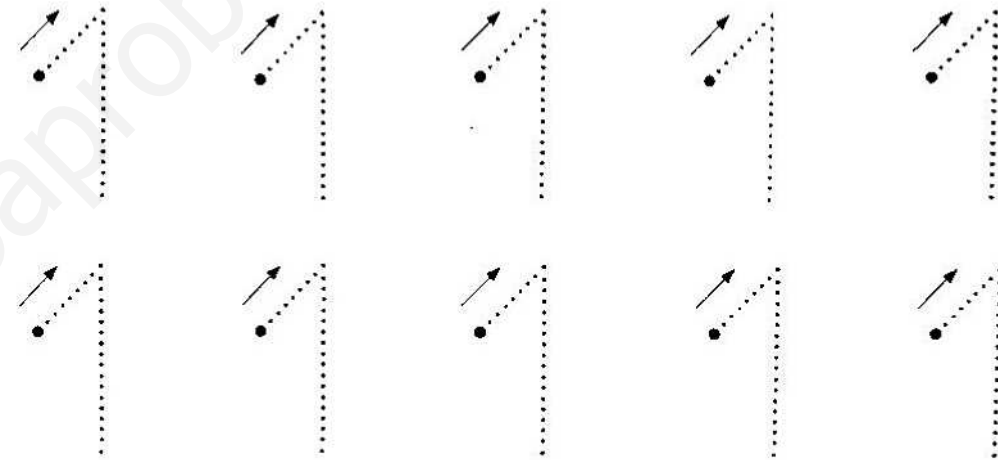
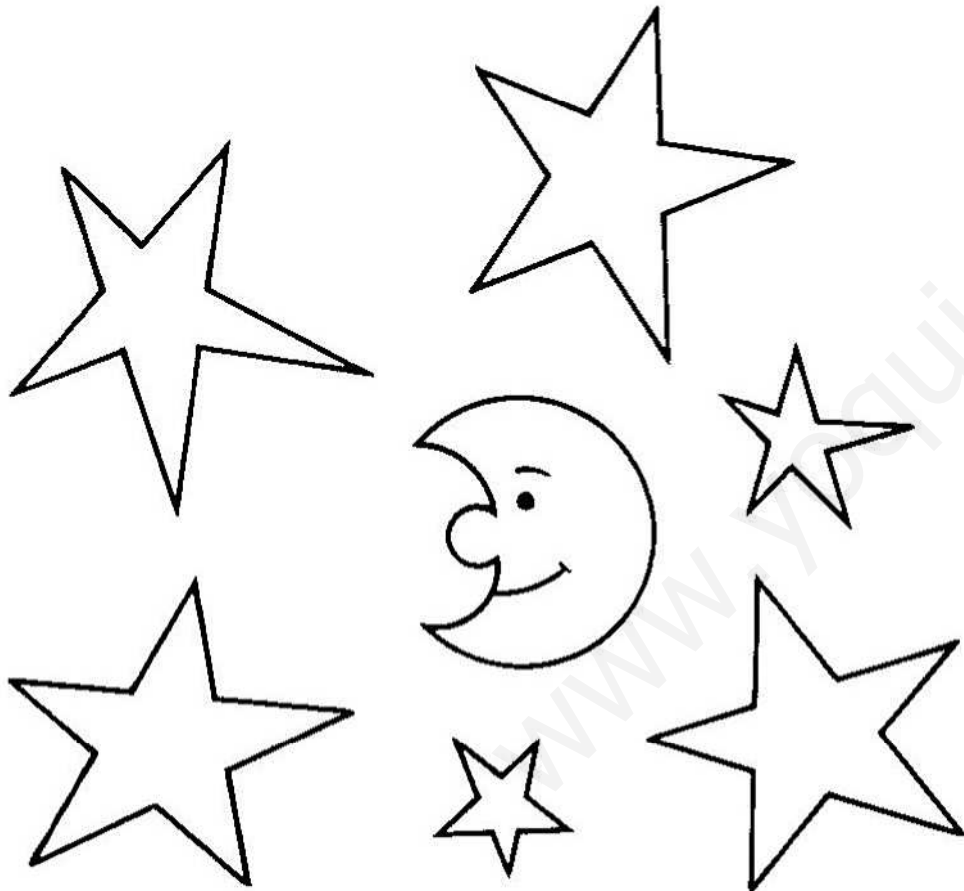
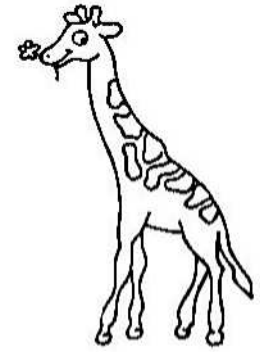
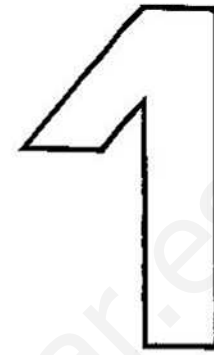
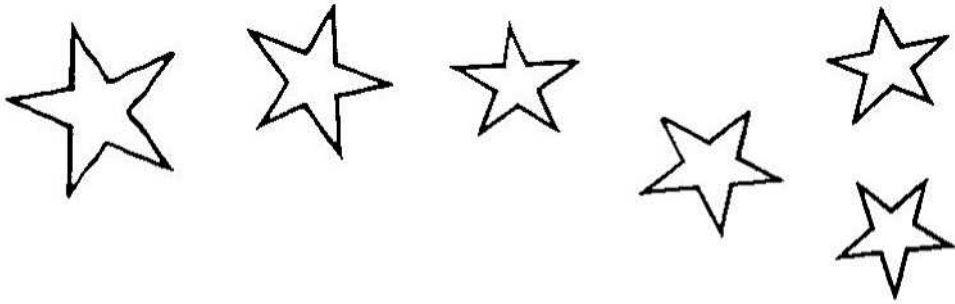

Colorea las estrellas que están cerca de la luna.

Colorea y escribe el número 1.

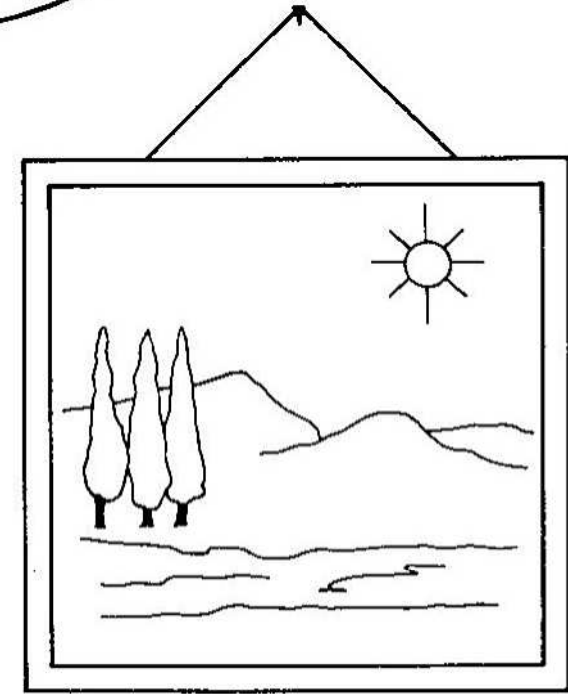
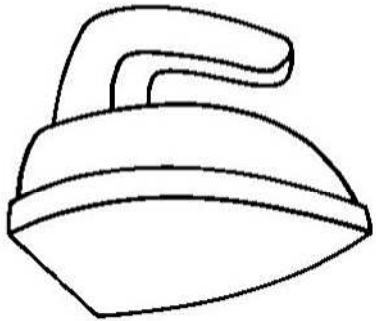
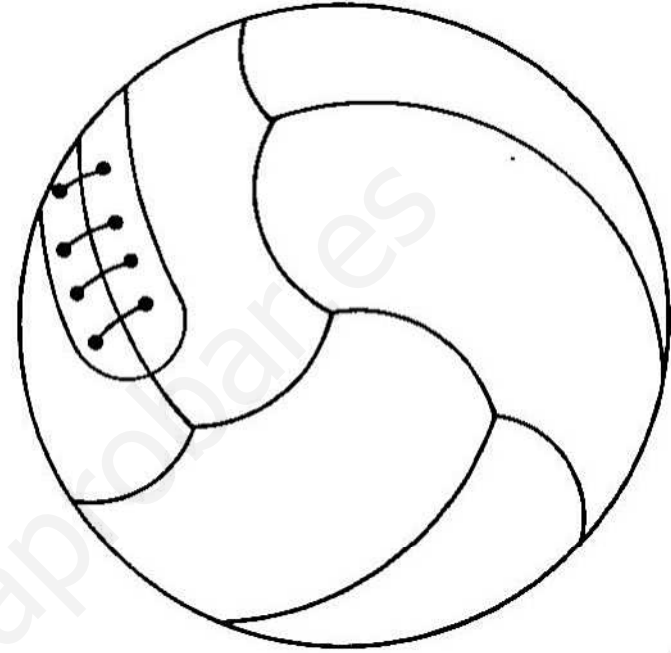
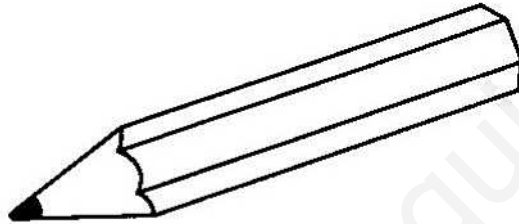
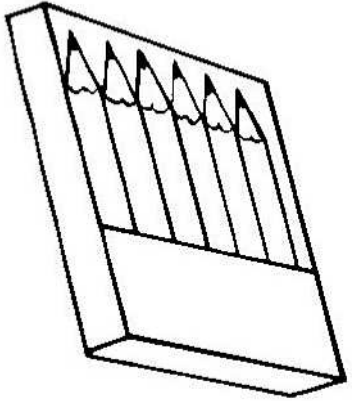
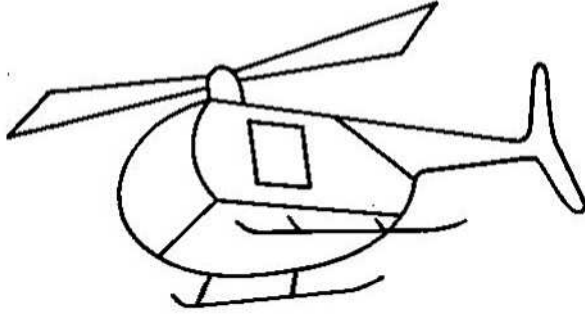
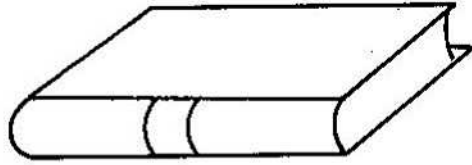
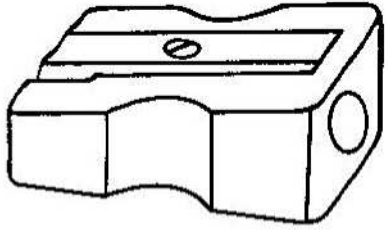

Colorea los objetos que pertenezcan al material escolar.

Colorea el dibujo que tiene forma cuadrada.

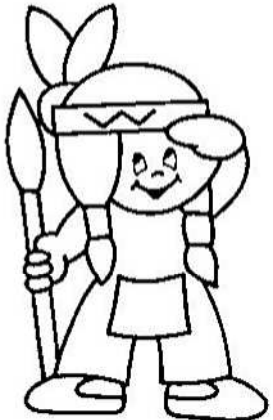
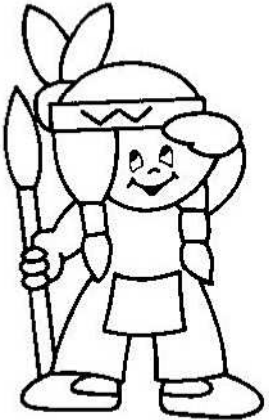
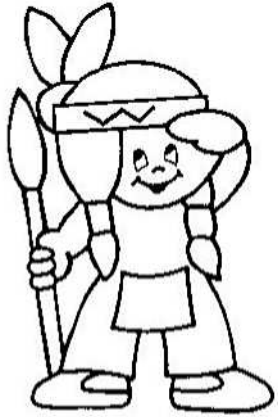

Une con una línea cada indio con su tienda y da color.

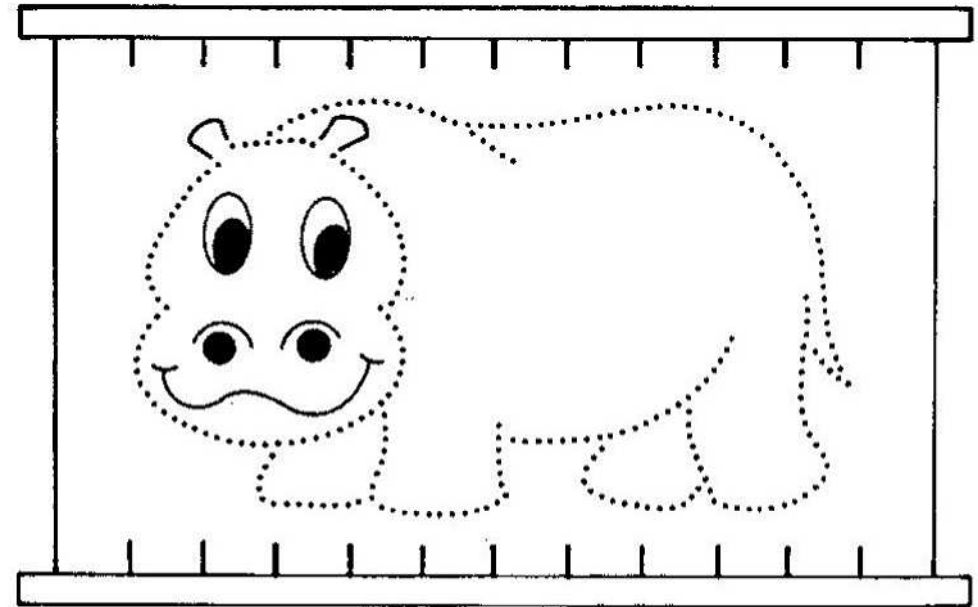
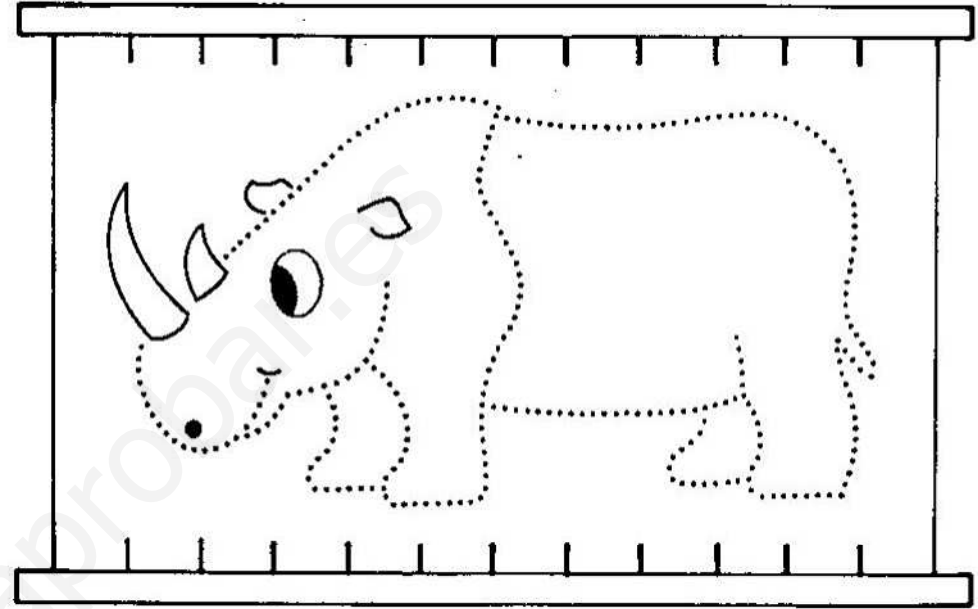

Sigue los puntos, colorea las fieras y traza los barrotes de las jaulas.

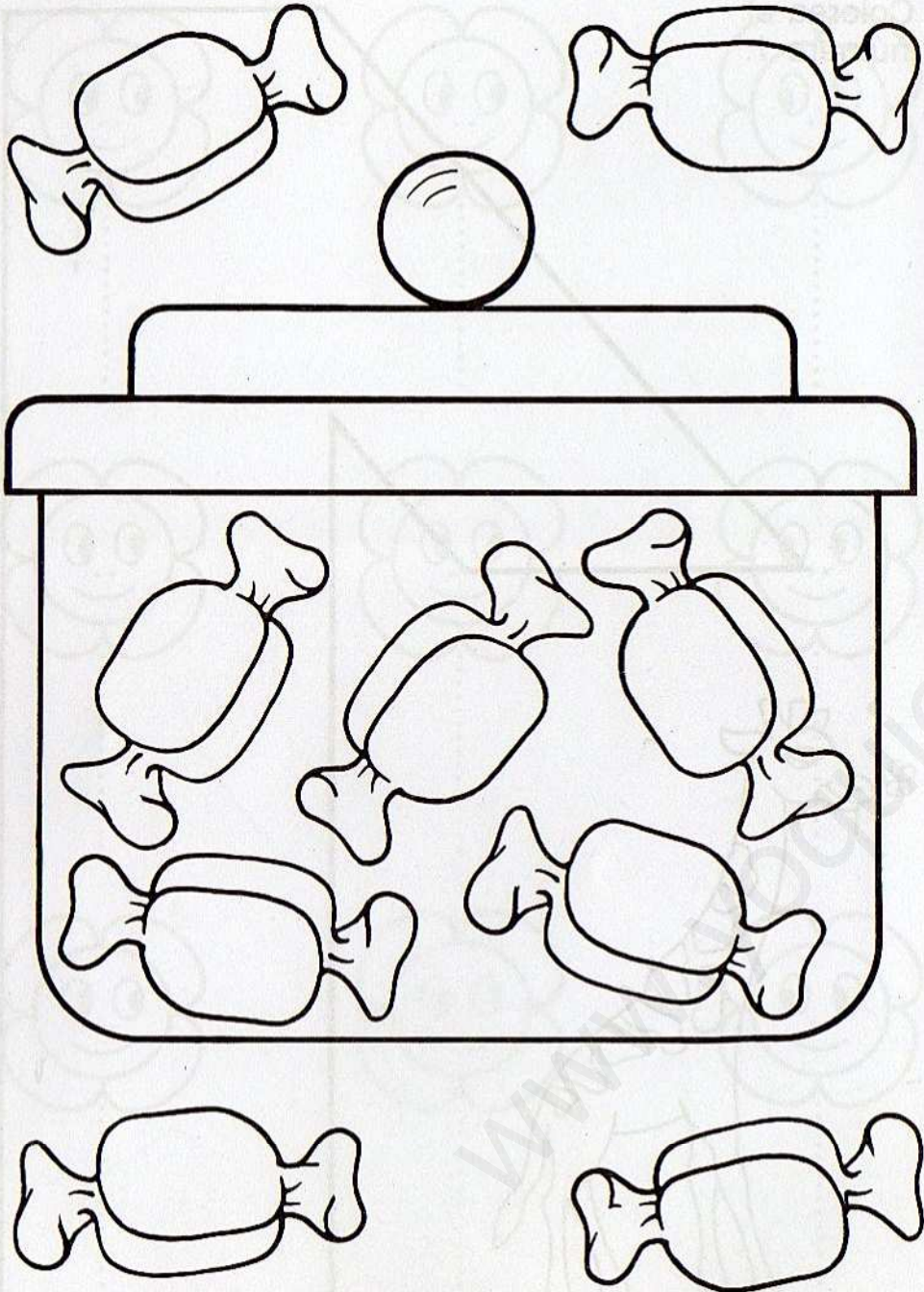

Pinta los caramelos que están dentro del bote.

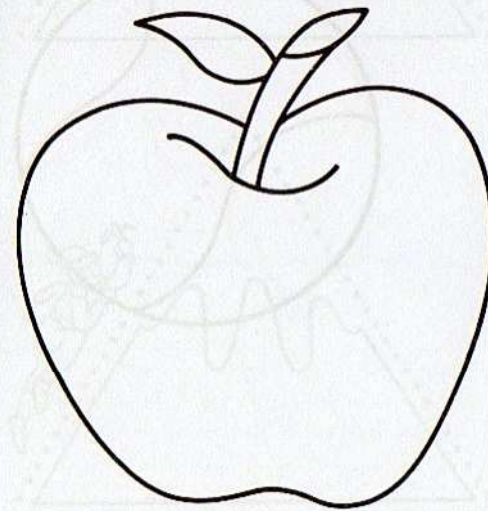
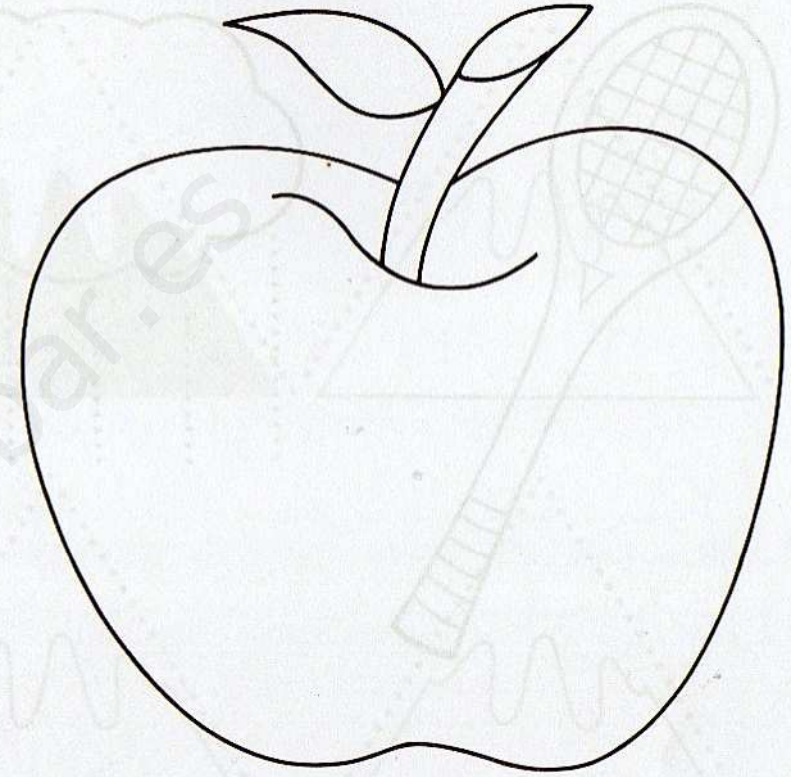

<http://www.libroselva.es>

Colorea la manzana más pequeña.

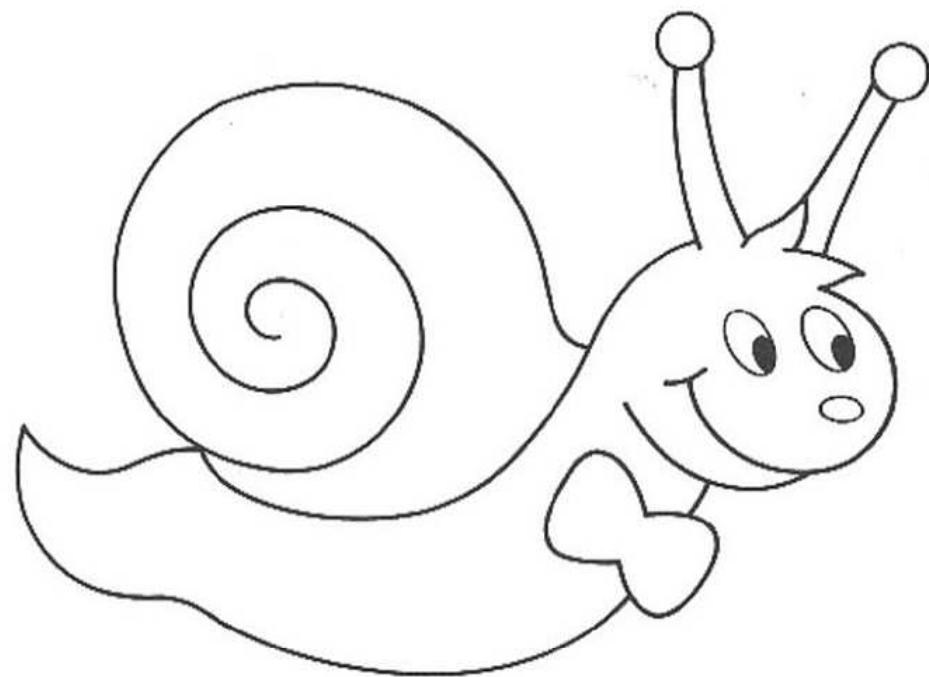
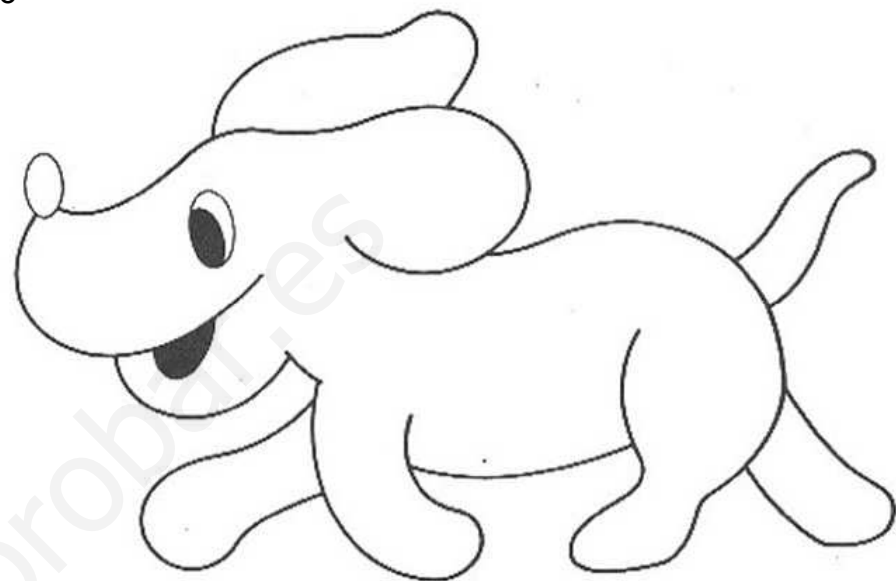
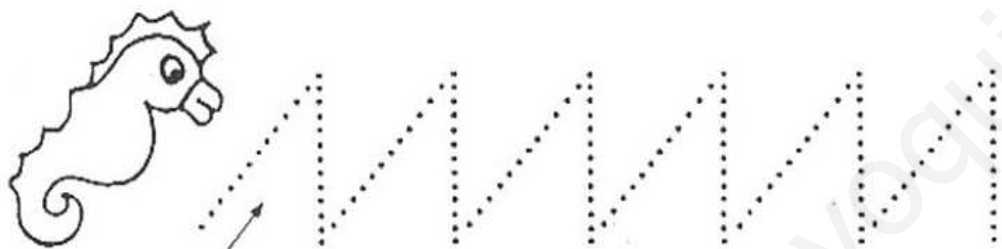
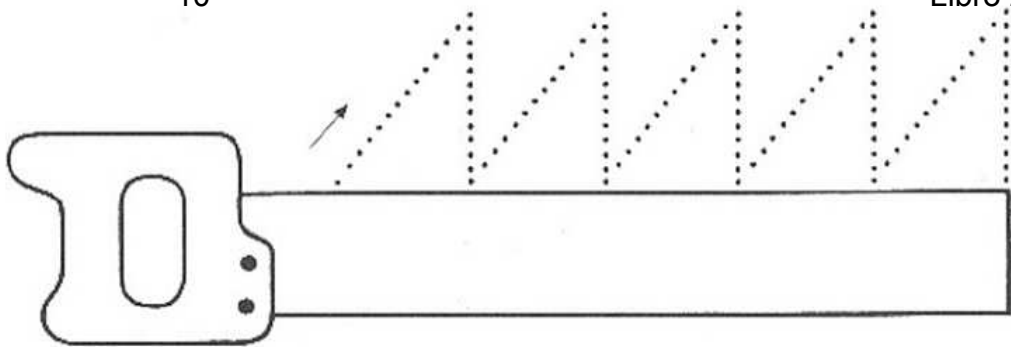

Repasa las líneas de puntos y colorea las figuras.

Colorea el animalito que va más despacio.

FELIZ NAVIDAD

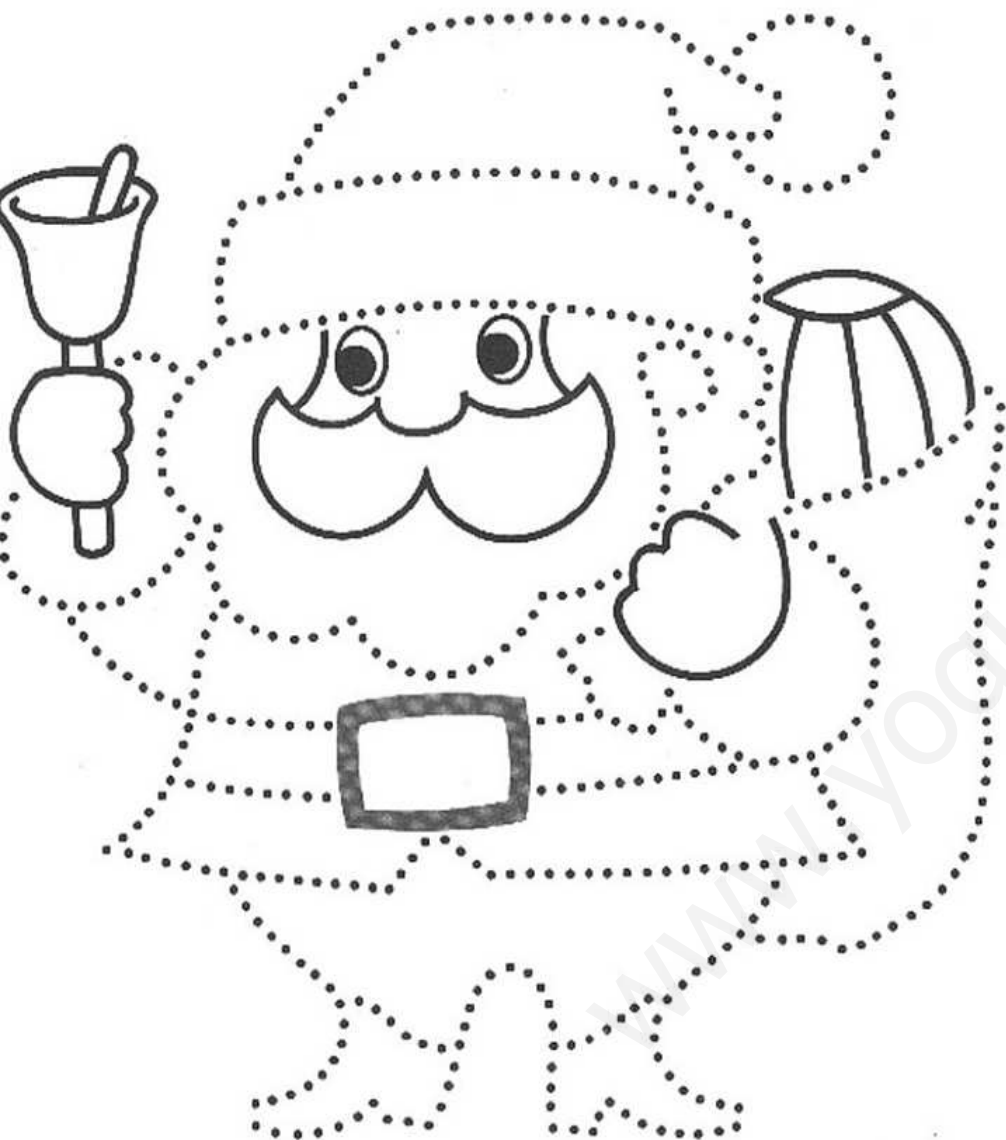

Sigue los puntos y da color.

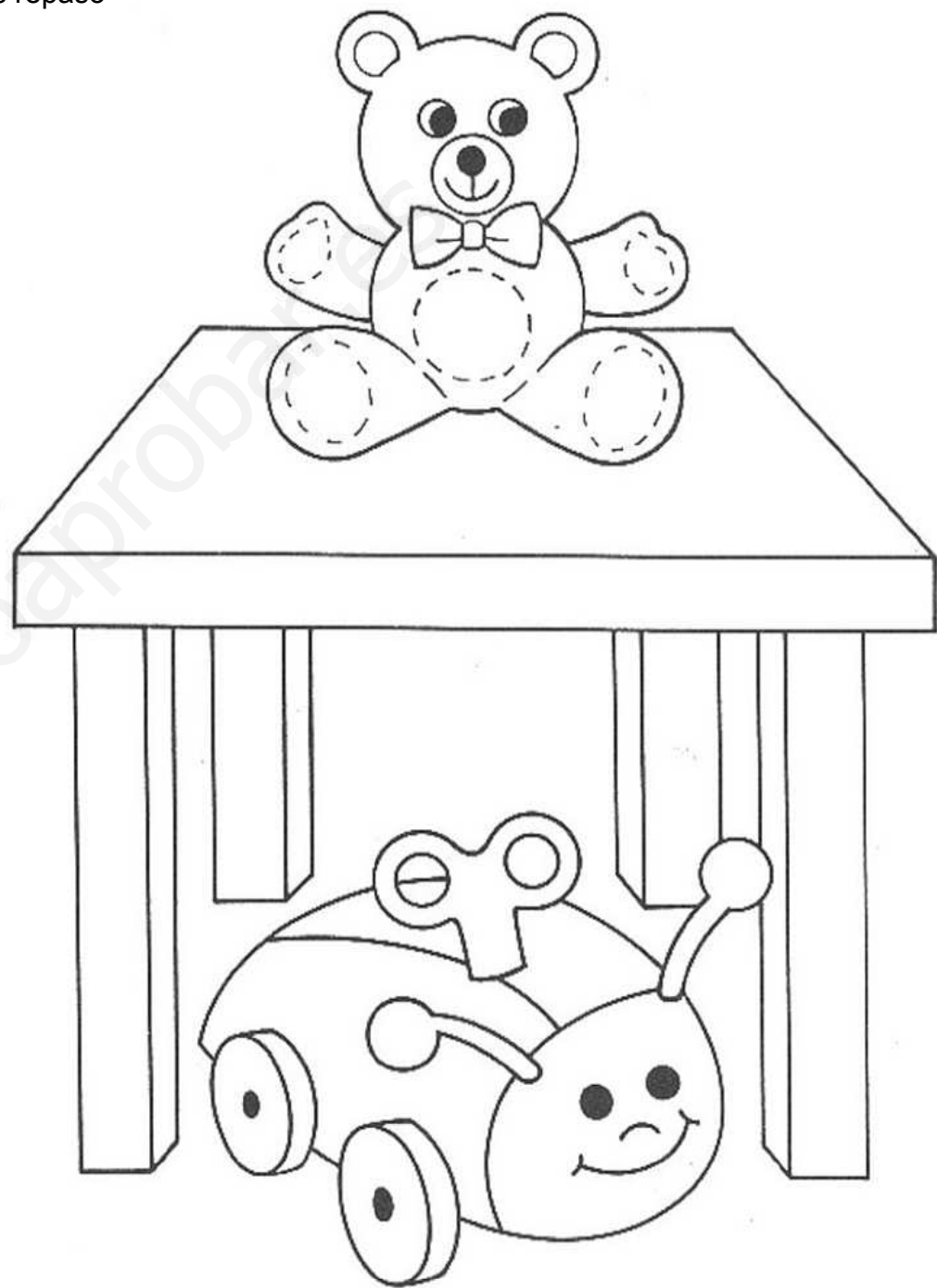

Colorea de amarillo el juguete que está encima de la mesa.

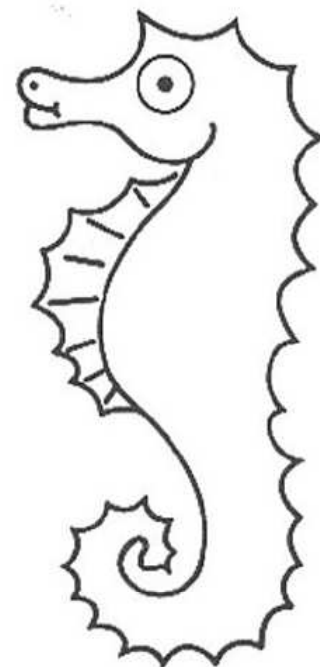
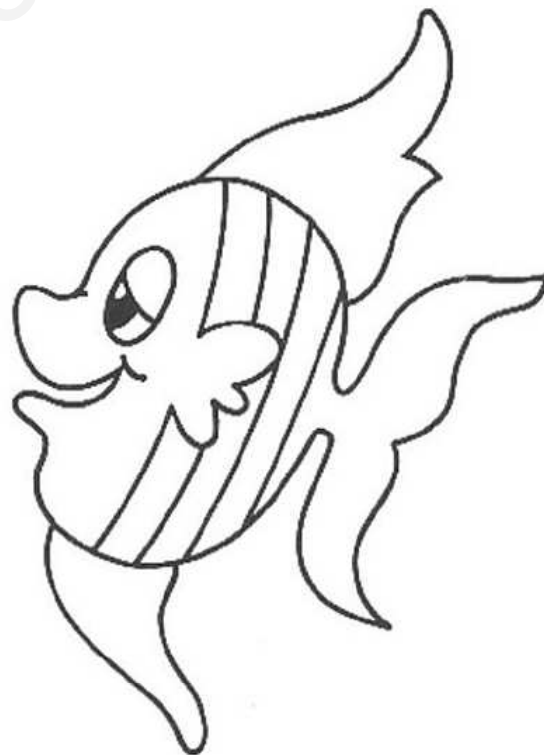
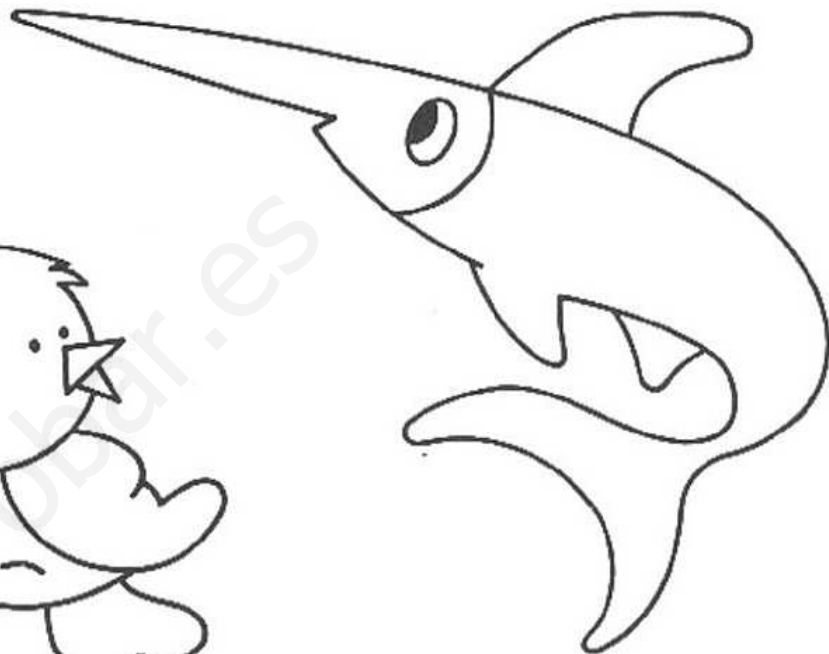
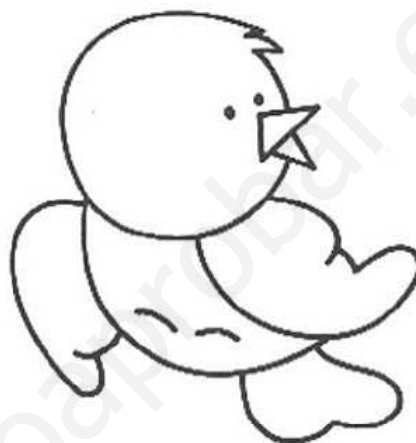
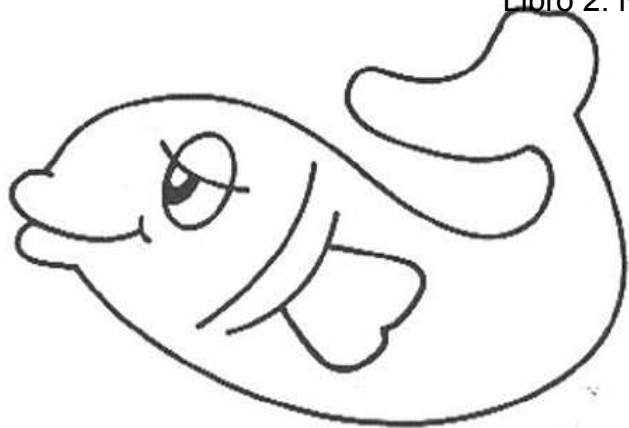

Colorea los animales que viven en el mar.

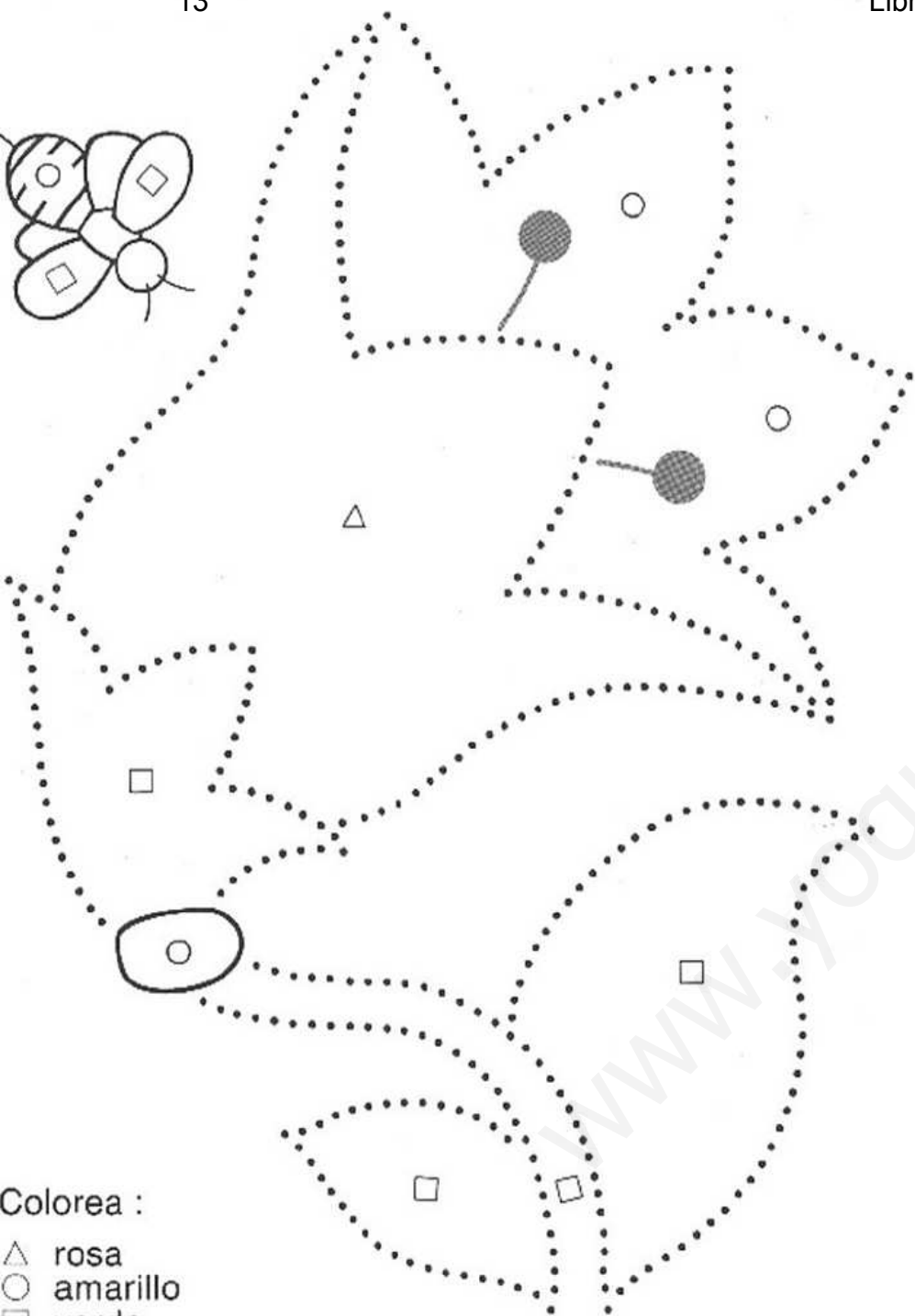

Colorea :

- △ rosa
- amarillo
- verde

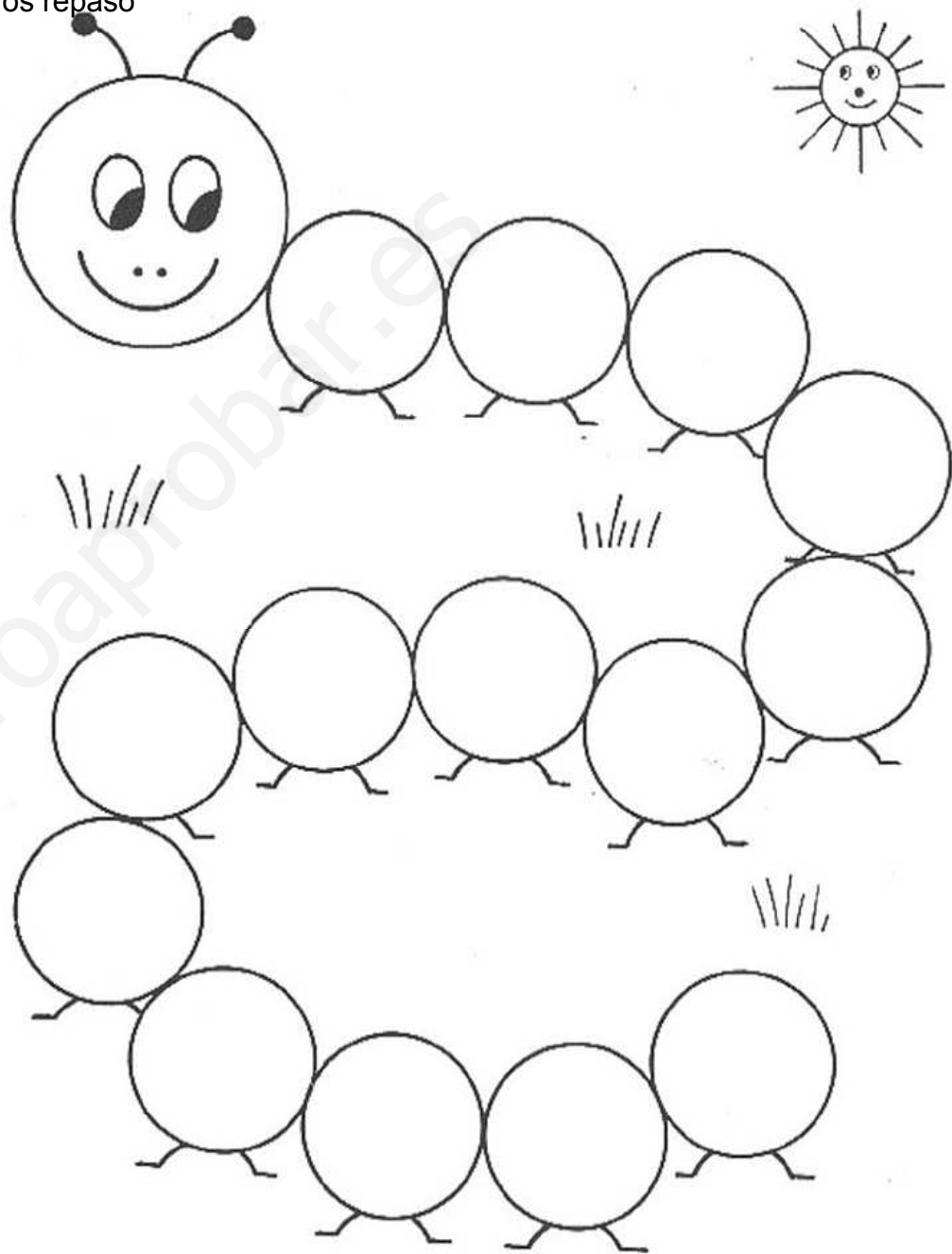

Colorea los círculos del gusano de verde y amarillo alternativamente.

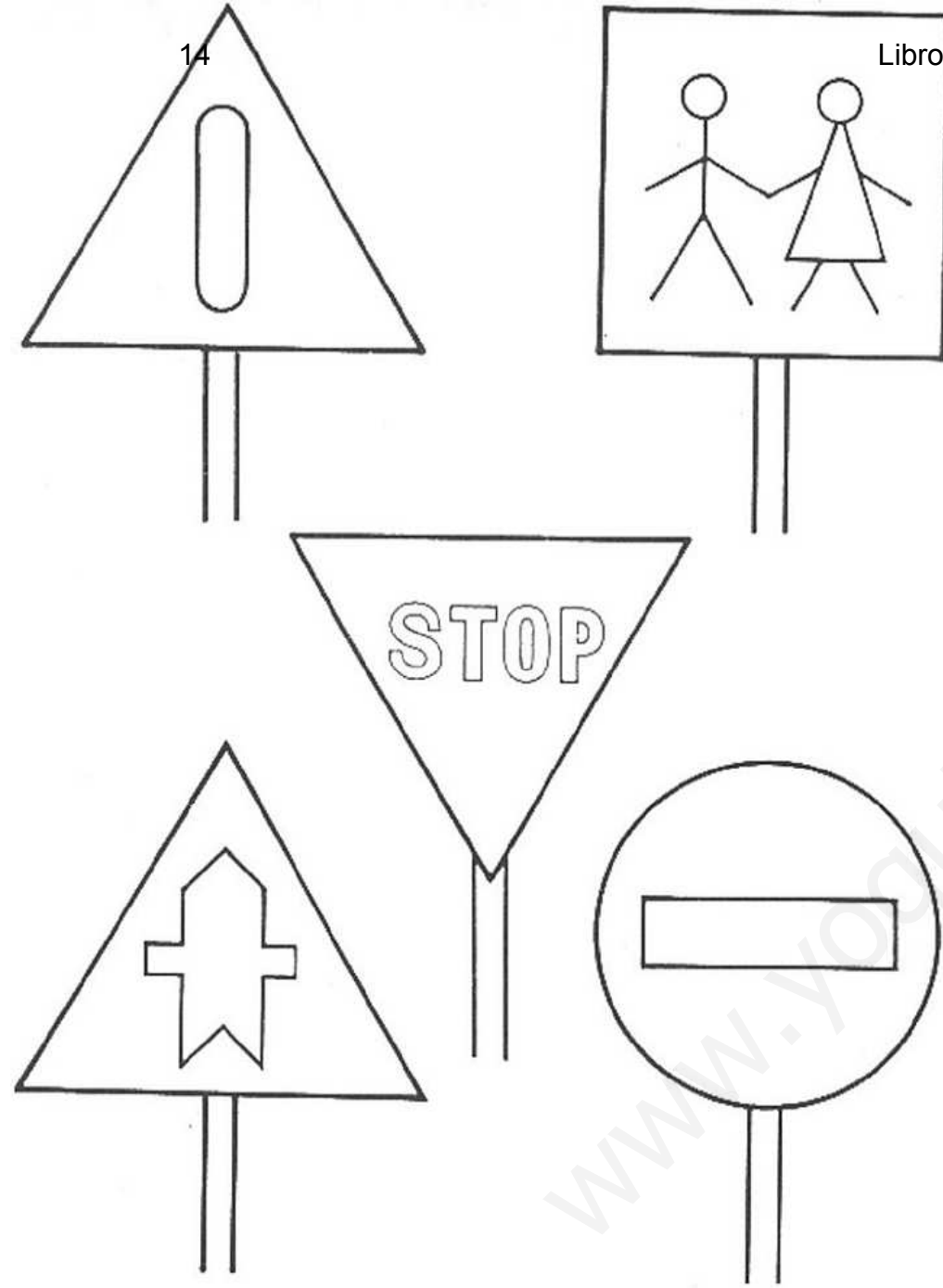

Colorea las señales que tienen forma de triángulo.

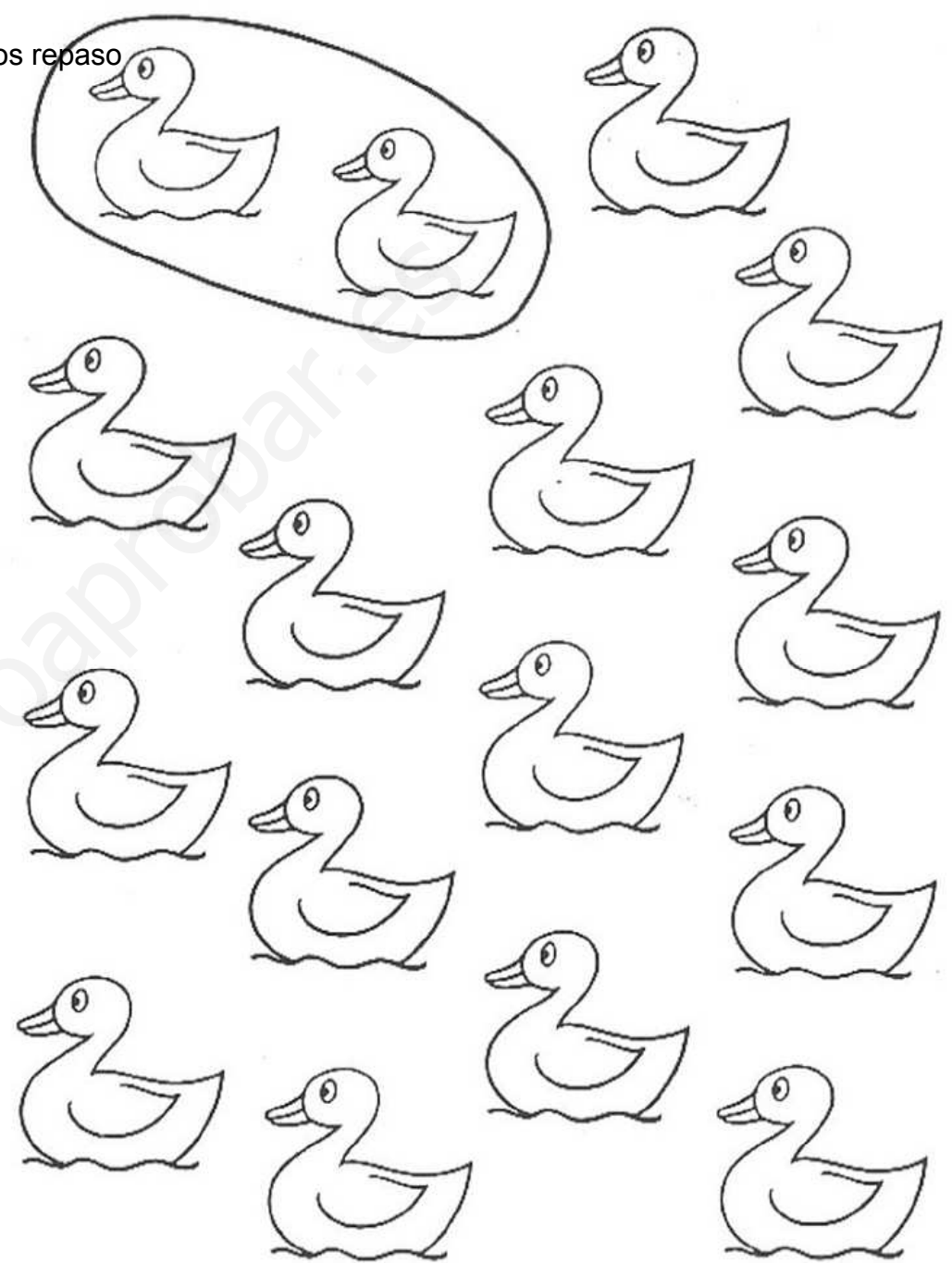

Pon los patitos de 2 en 2 dentro de un contorno como la muestra y coloréalos.

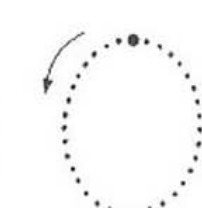
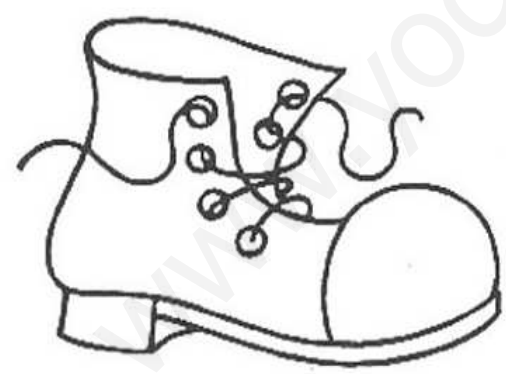
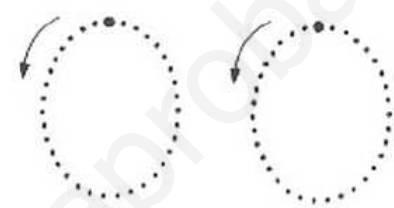
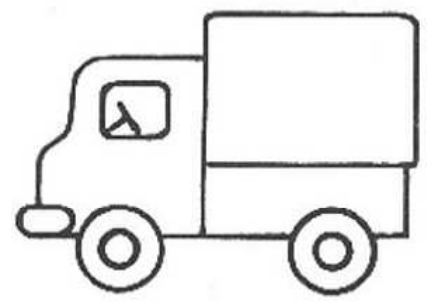
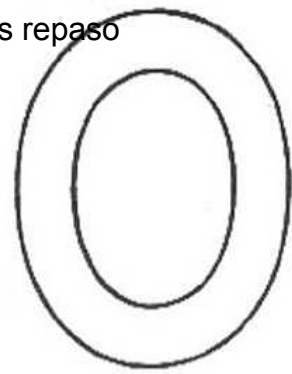
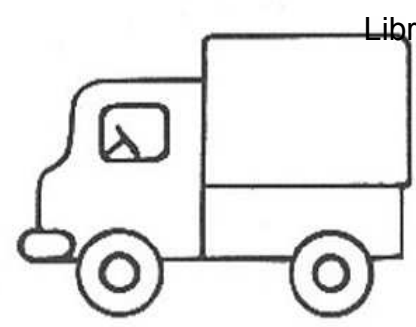
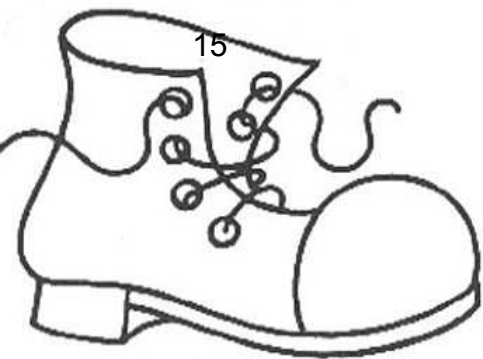

Une con una línea los dibujos que veas iguales y píntalos del mismo color.



Escribe la letra o y colorea.

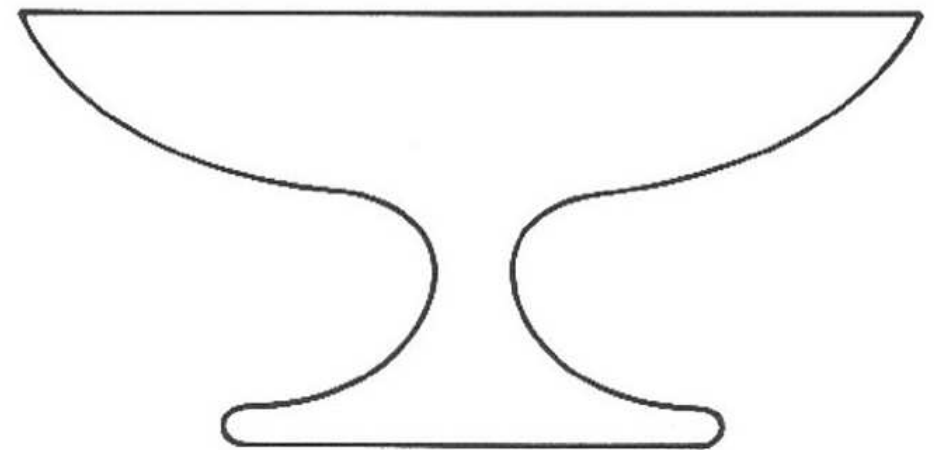
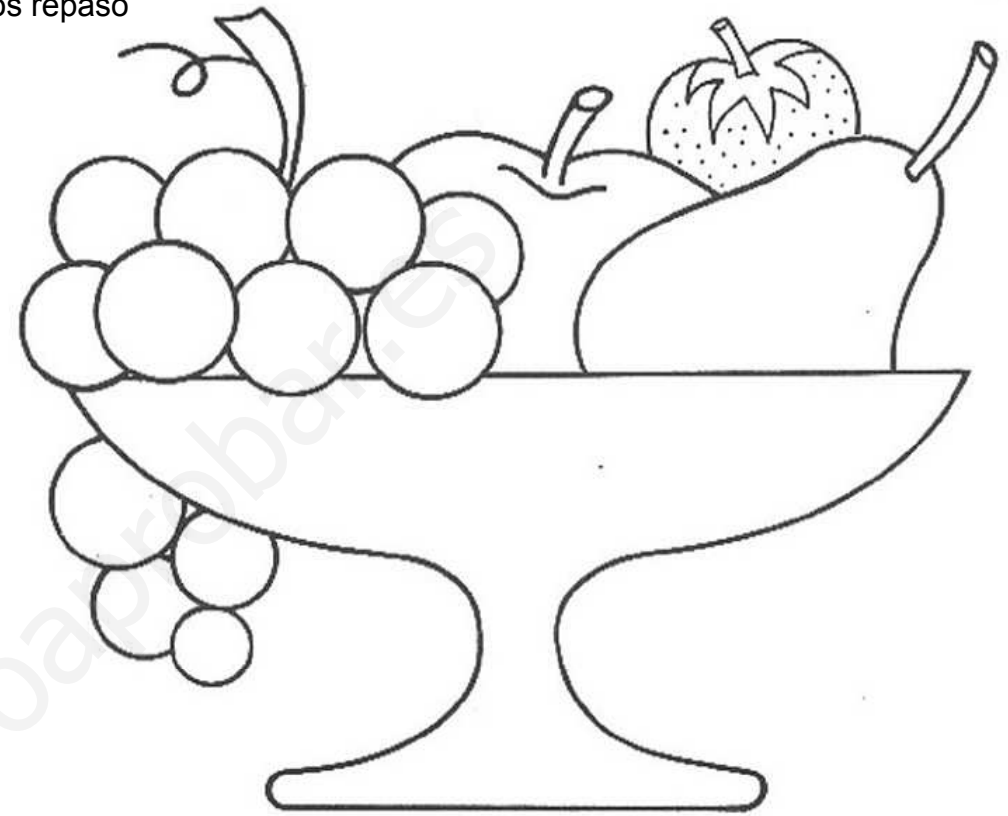
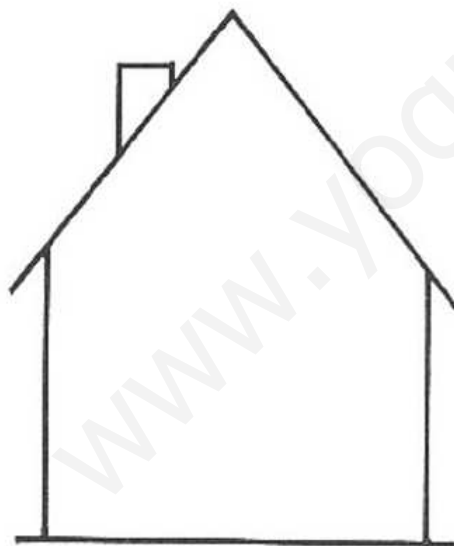
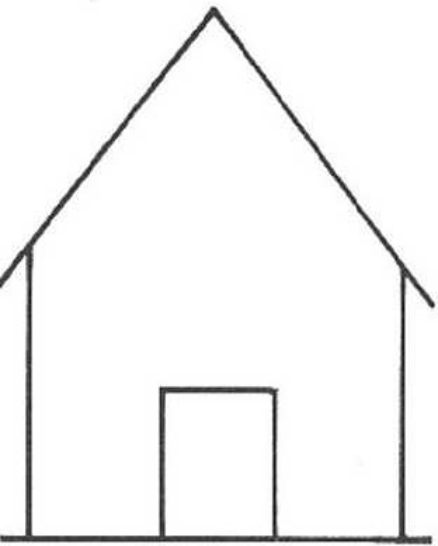
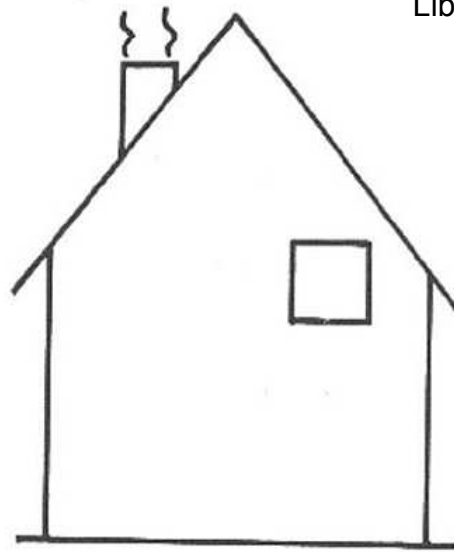
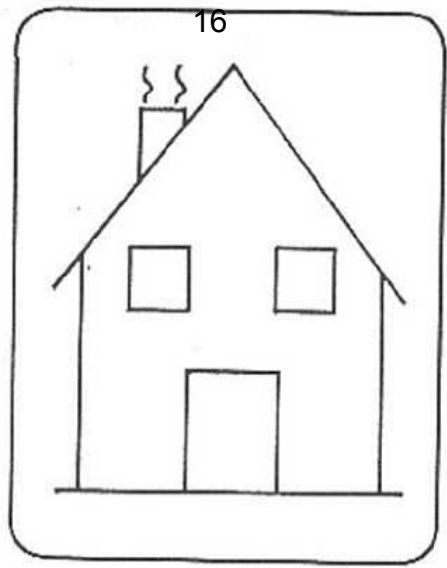

Completa las casas como la del recuadro y píntalas.

Colorea el frutero que está lleno.

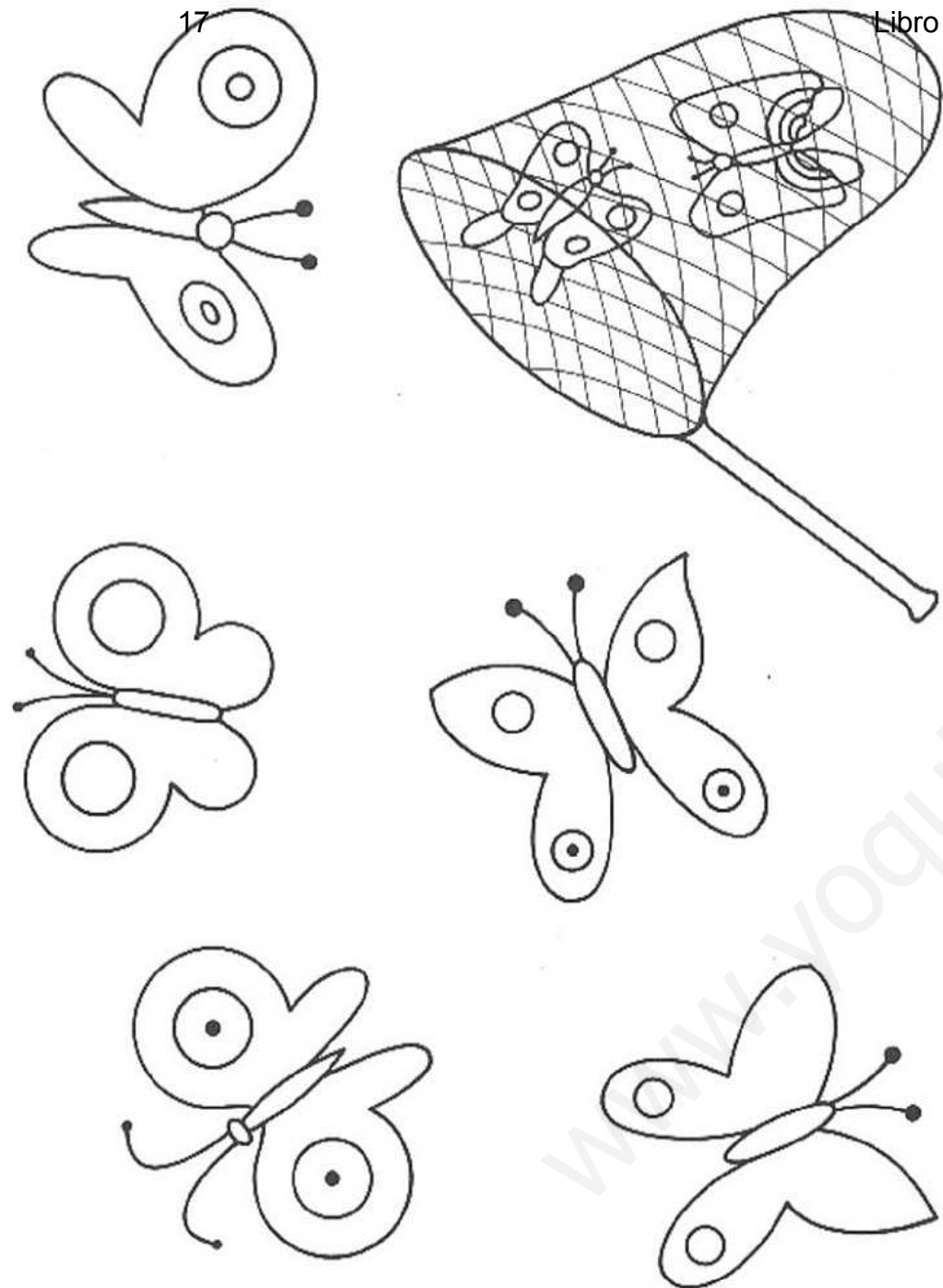

Pinta las mariposas que están fuera de la red.

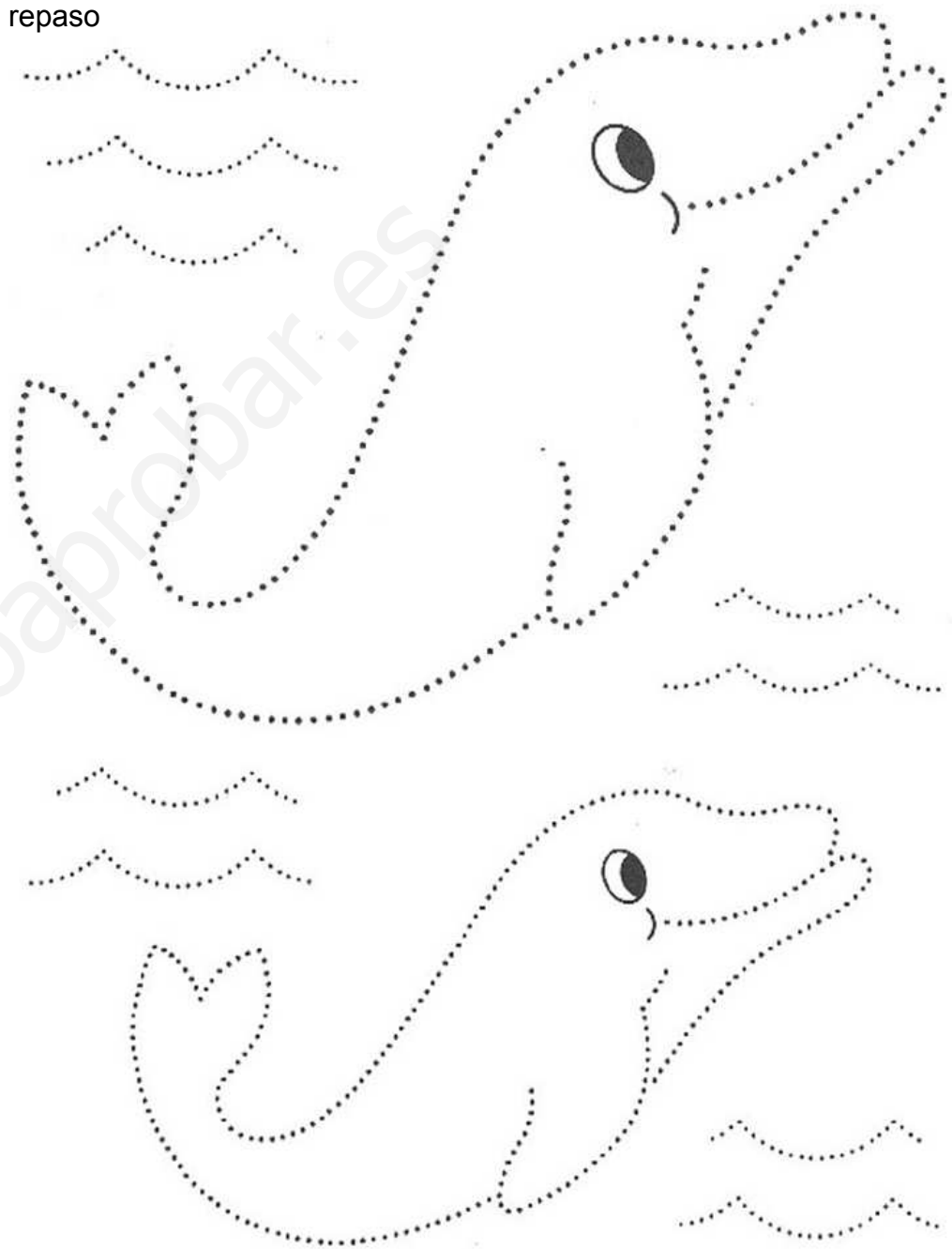

Sigue los puntos y colorea de azul el delfín grande y de rosa el pequeño.

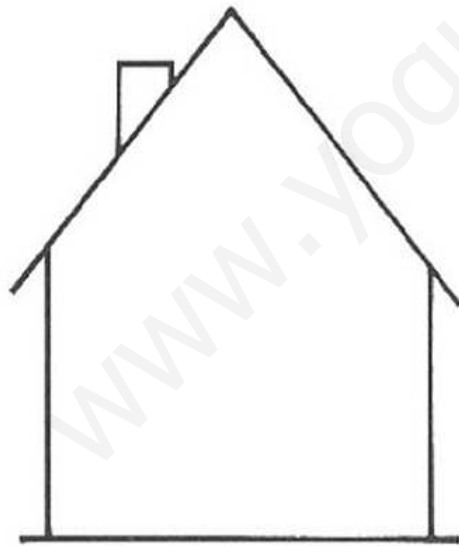
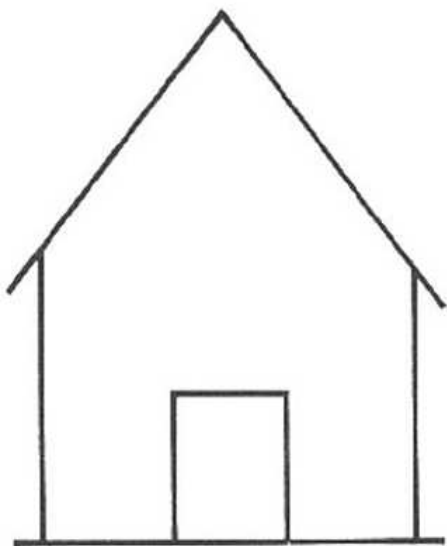
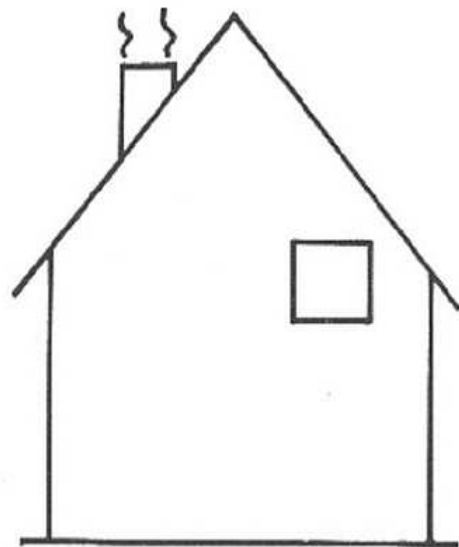
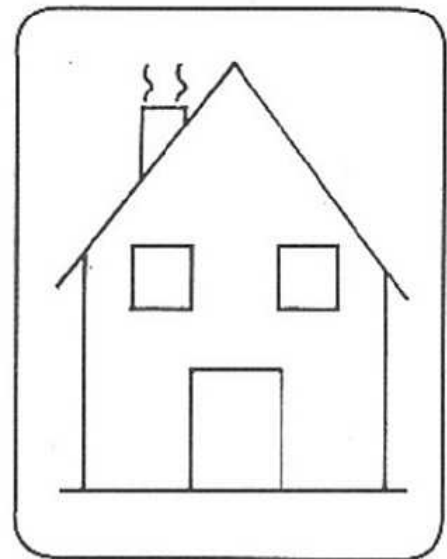

Completa las casas como la del recuadro y píntalas.

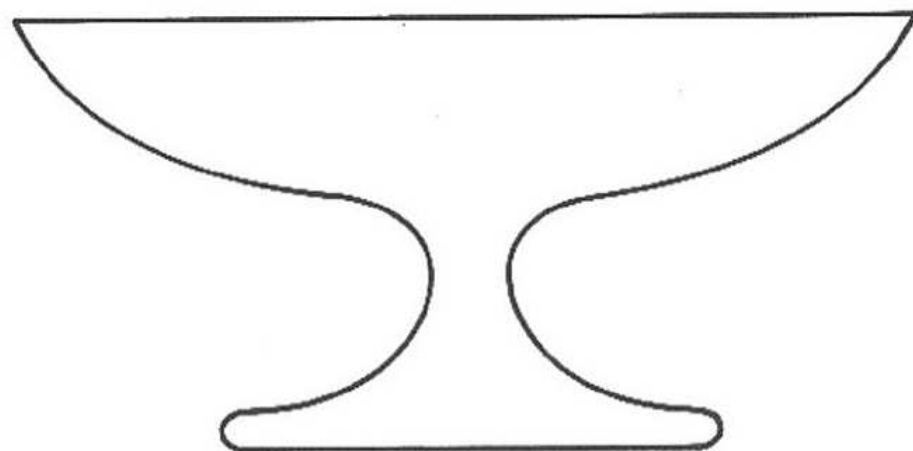
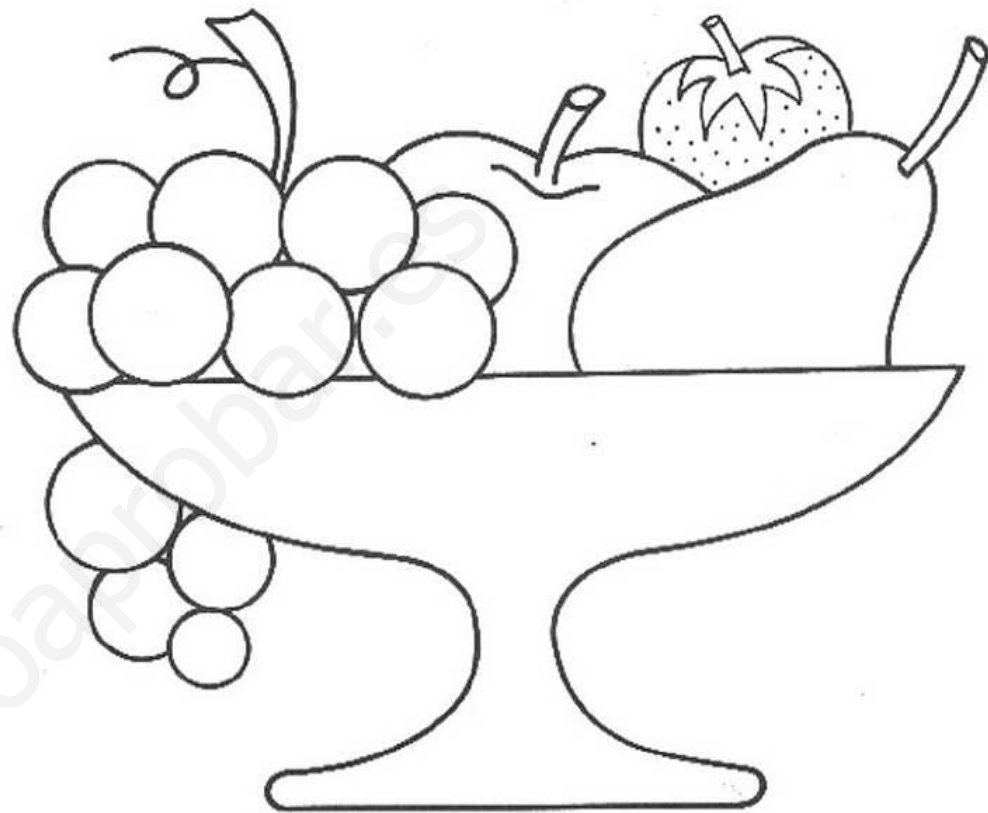

Colorea el frutero que está lleno.

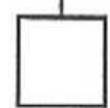
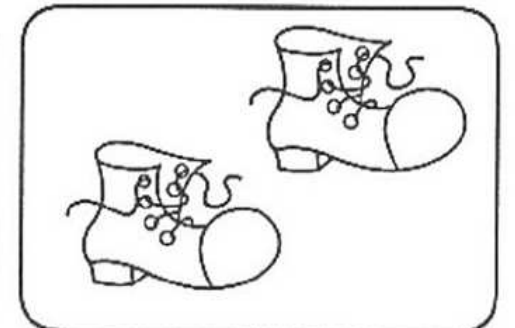
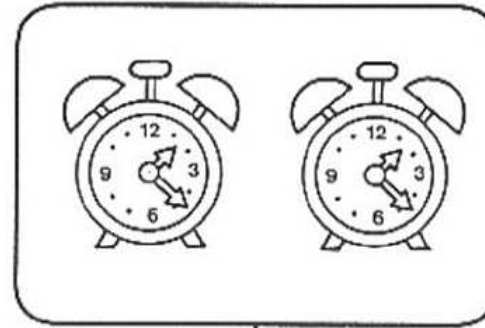
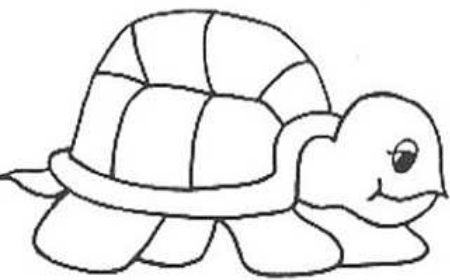
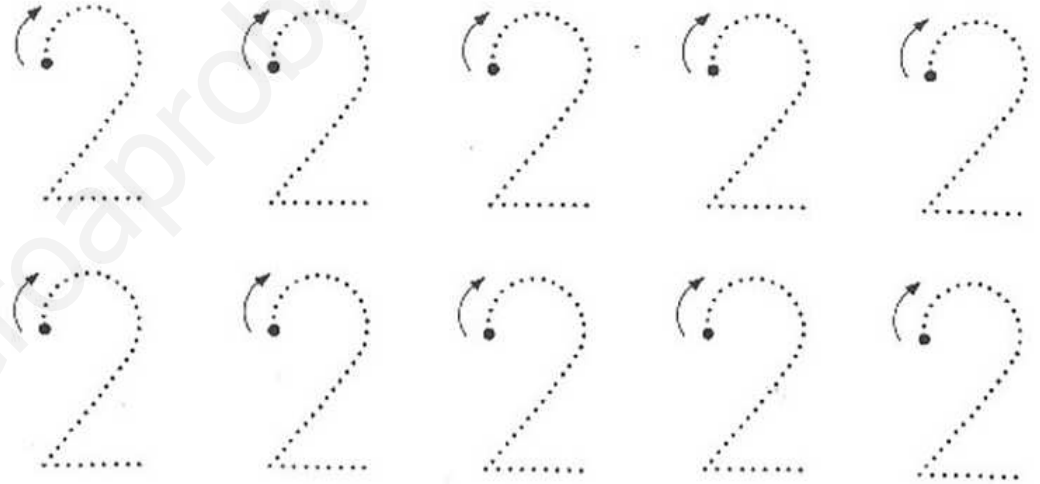
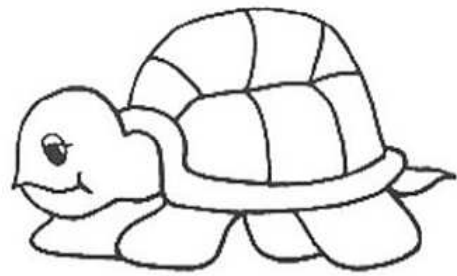
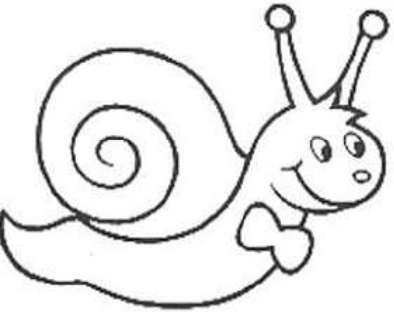
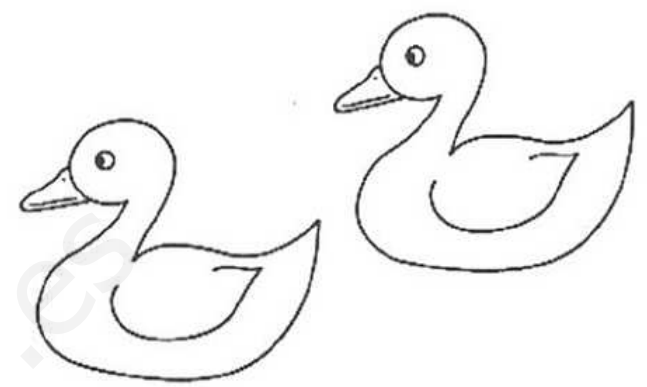
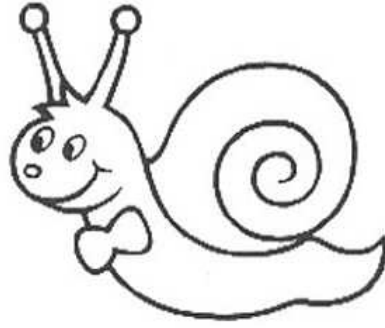
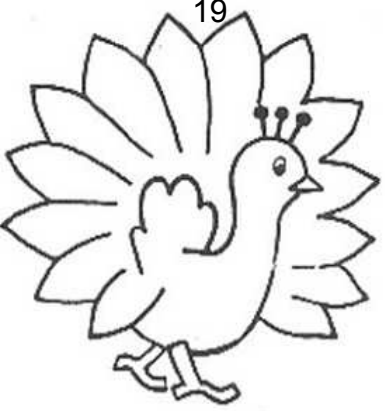

Une con una línea los dibujos que veas iguales y píntalos del mismo color.

Colorea y escribe el número 2.

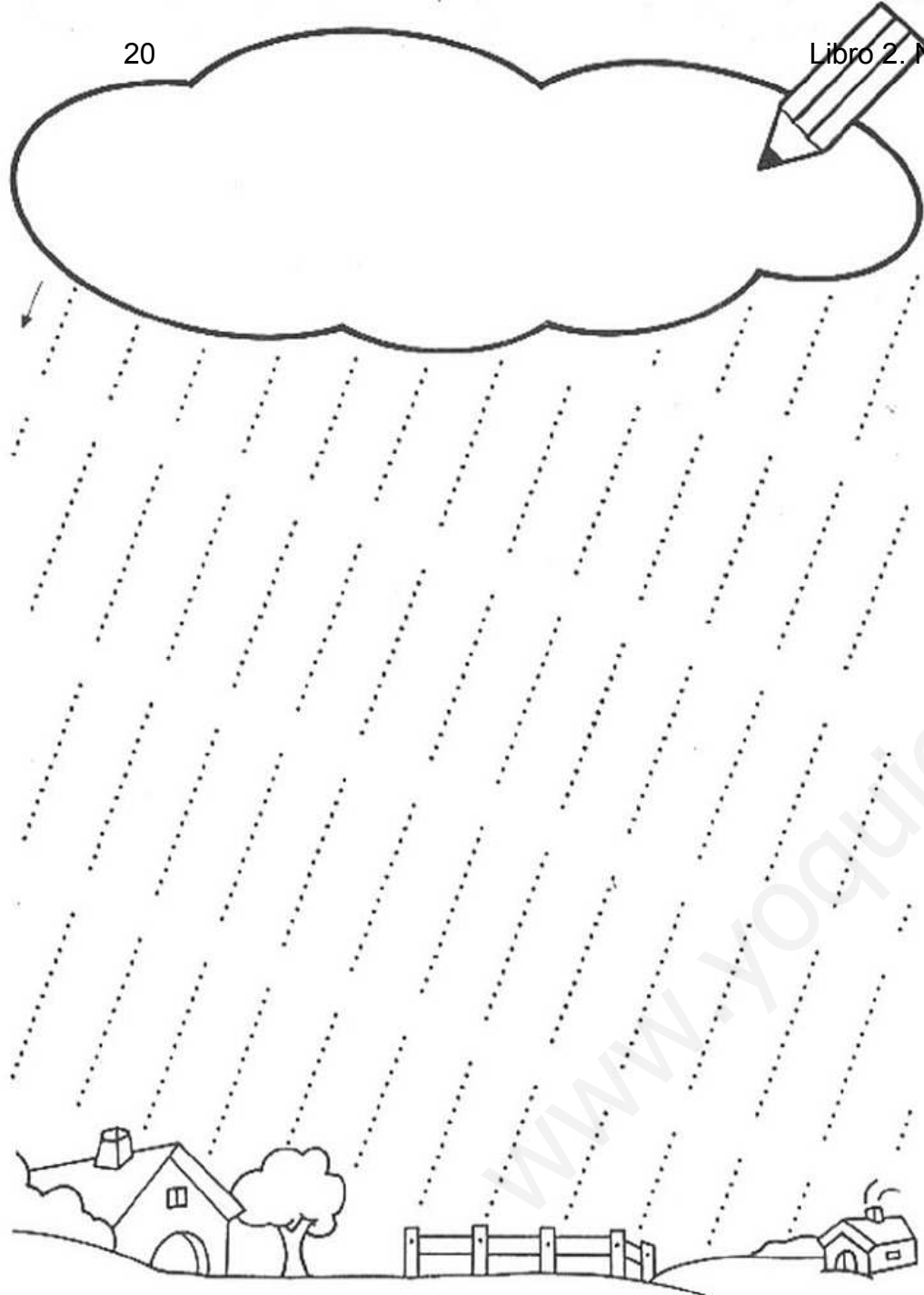

Traza las líneas de lluvia y colorea la nube.

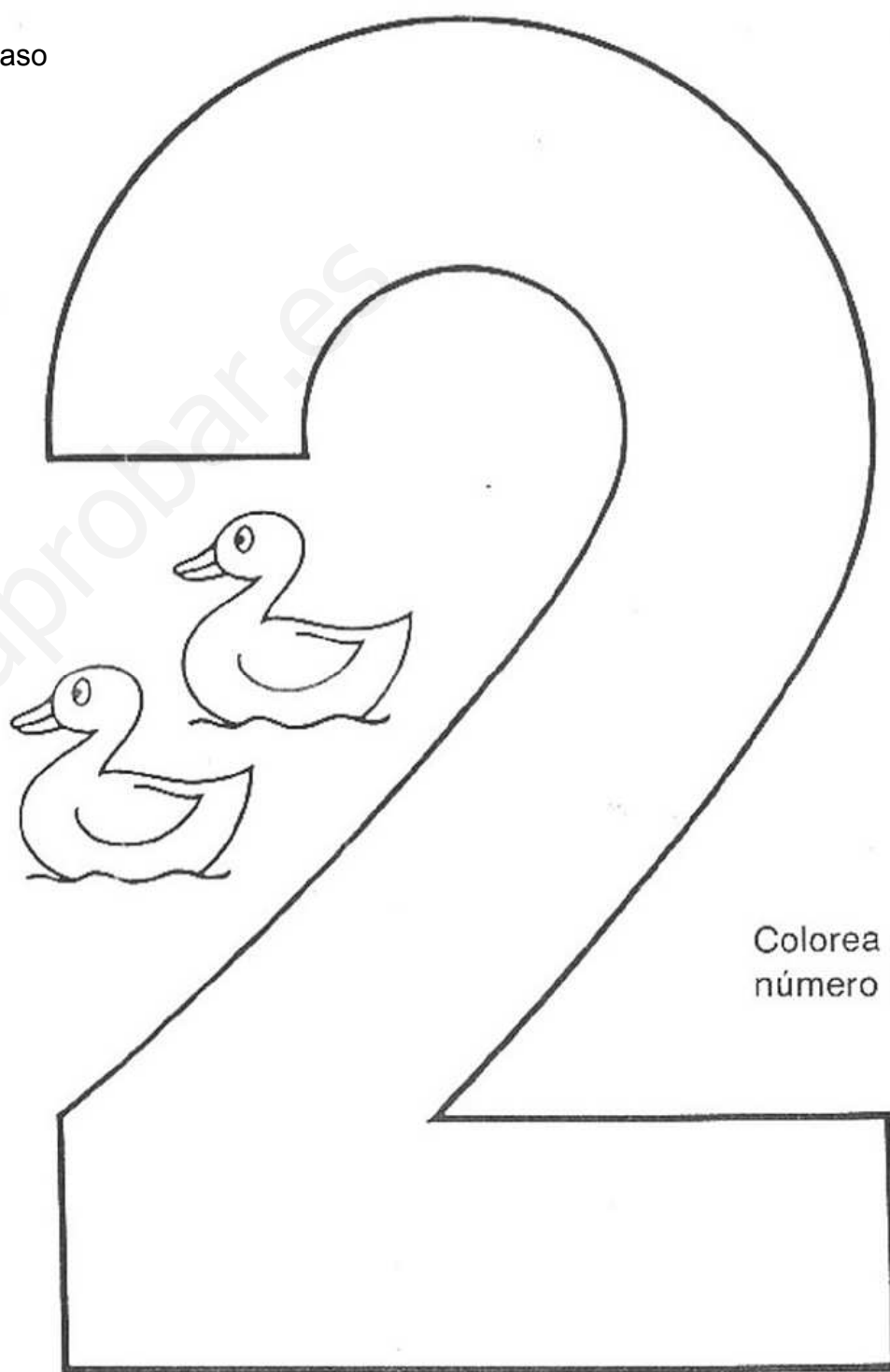

Colorea el número 2.

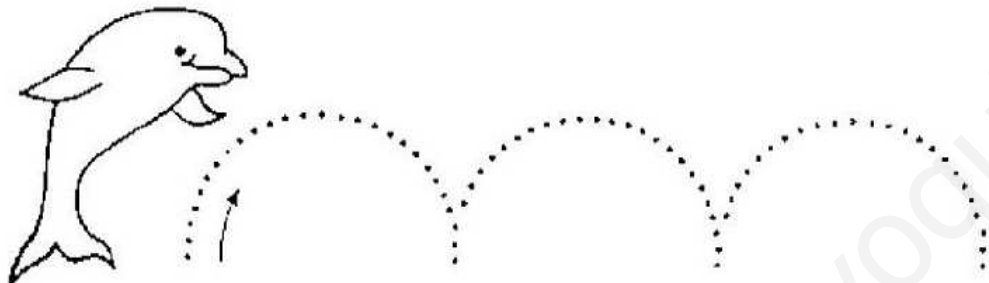
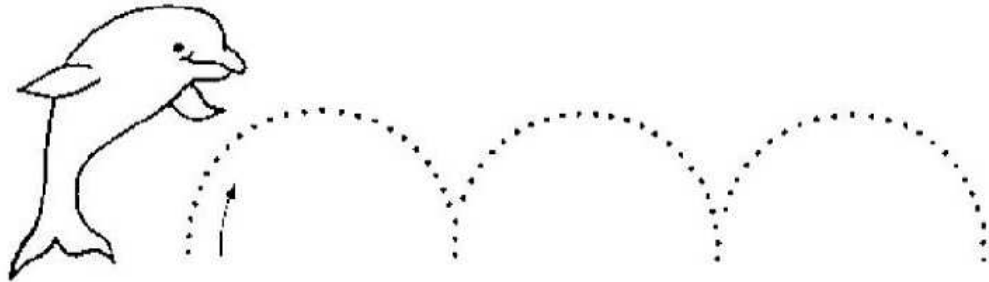
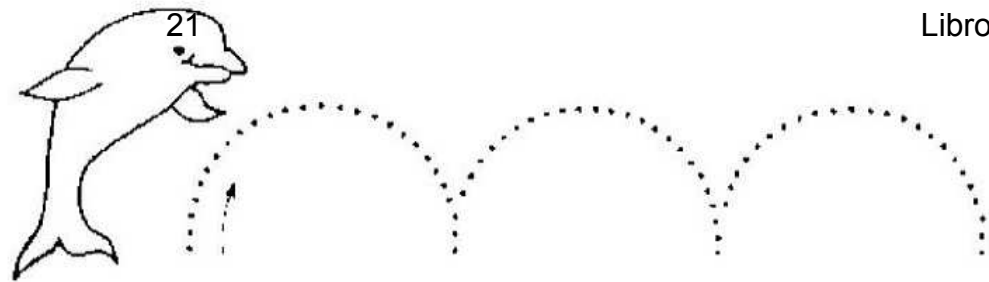

Repasa las líneas de puntos y colorea los delfines.

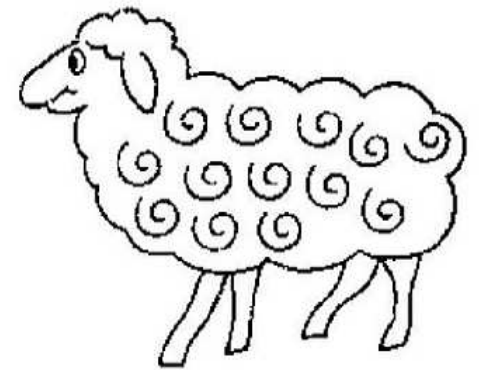
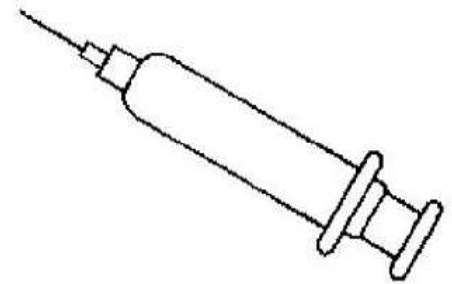
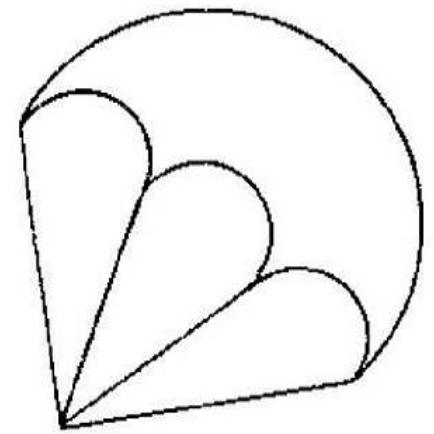

Une con una línea los dibujos que se correspondan y píntalos

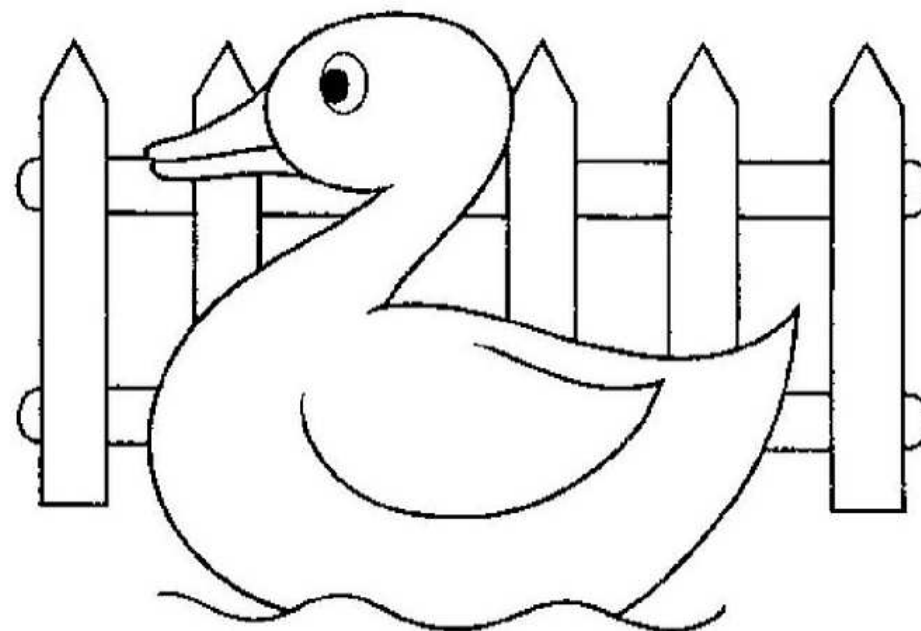
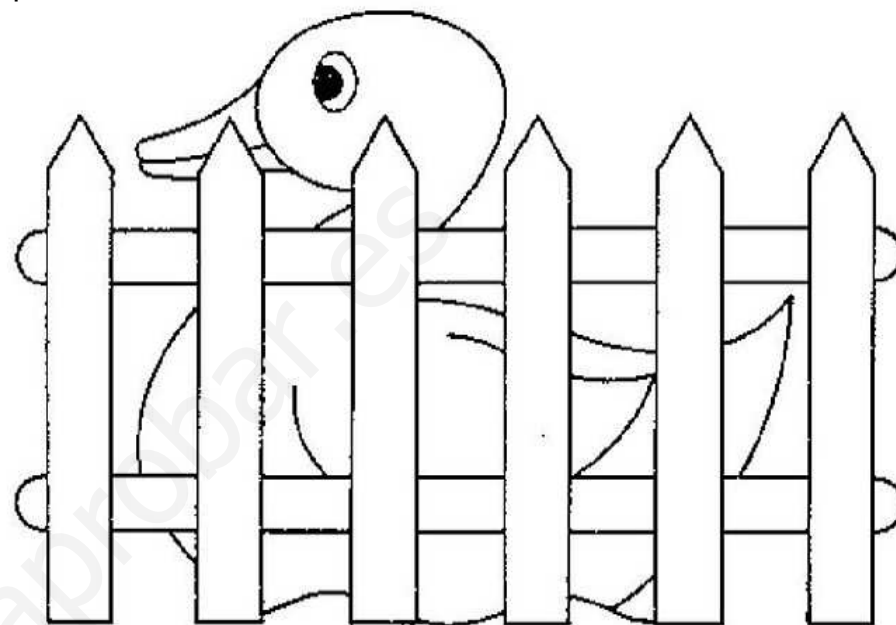
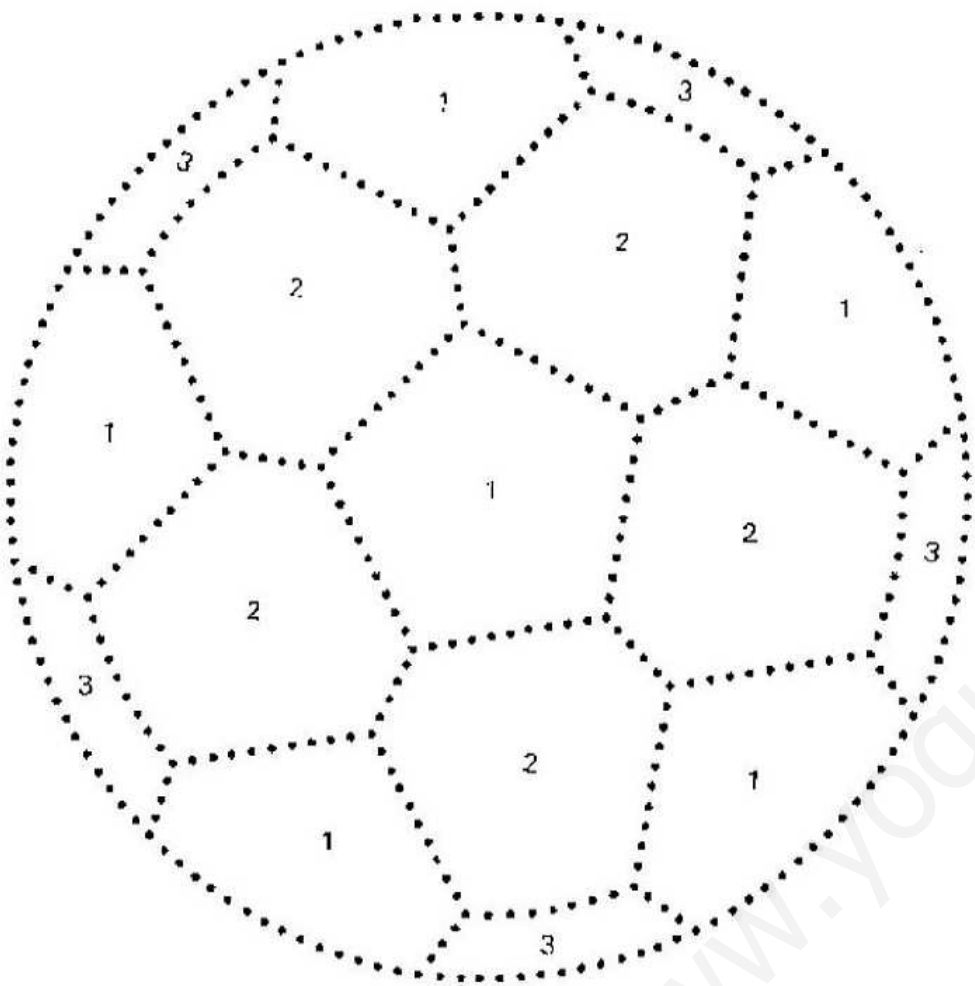

Sigue los puntos y colorea:
1 en rojo, 2 en verde y 3 en negro.

Colorea el patito que está delante de la valla.

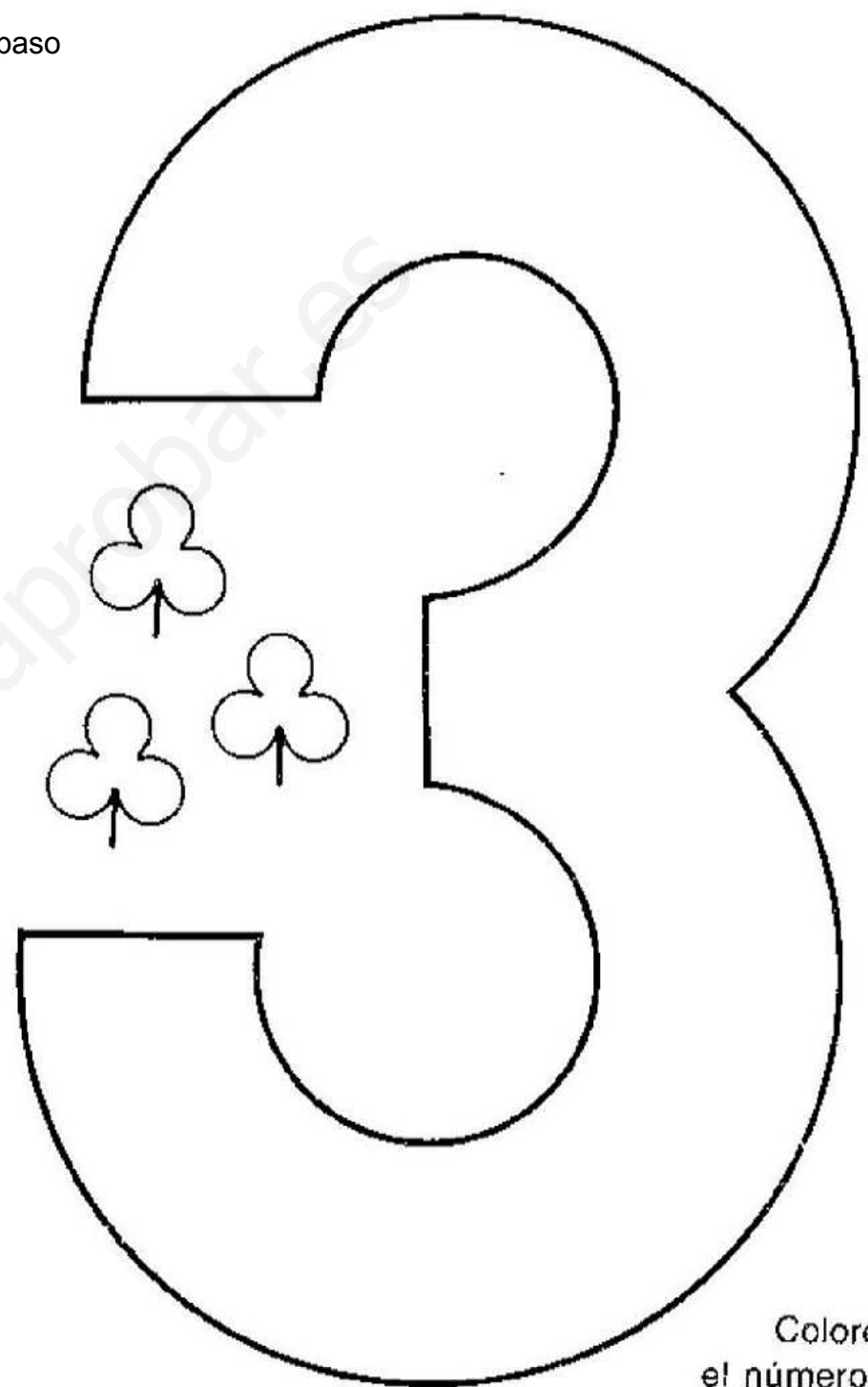
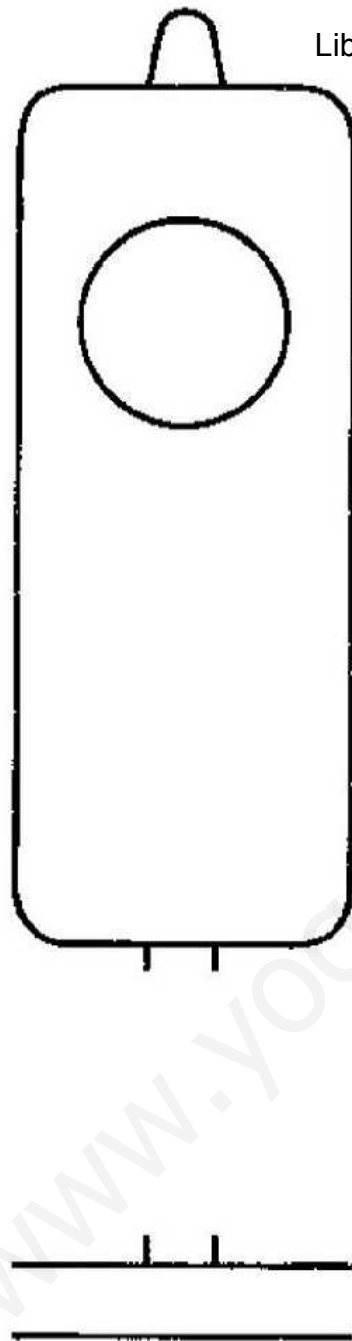
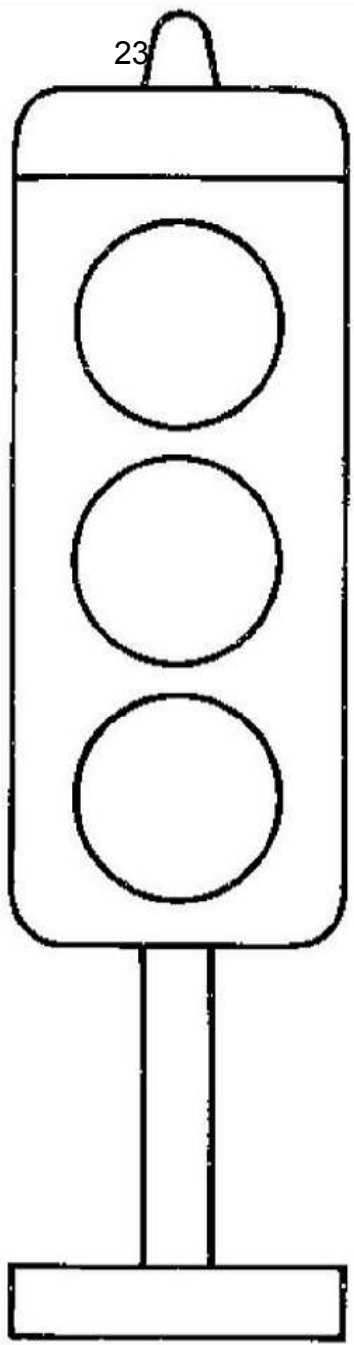

Completa el semáforo de la derecha y pinta los dos.

Colorea el número 3.

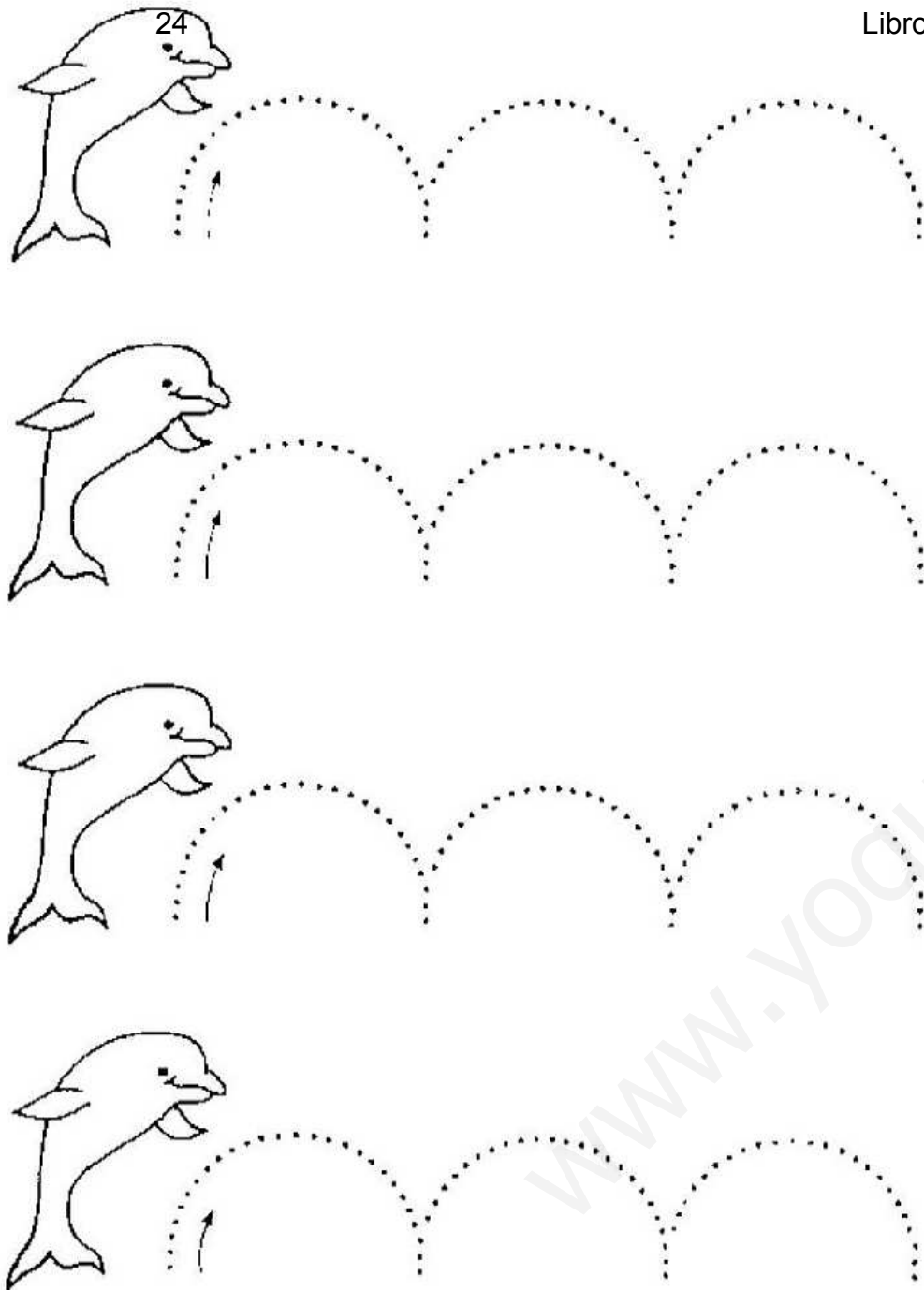

Repasa las líneas de puntos y colorea los delfines.

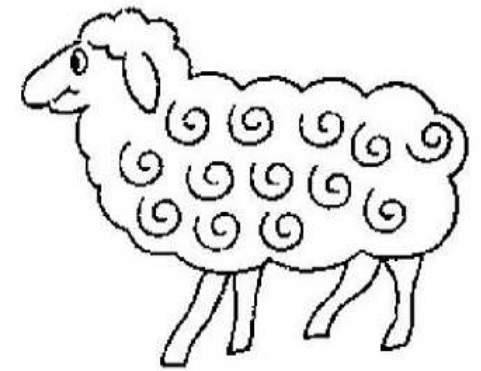
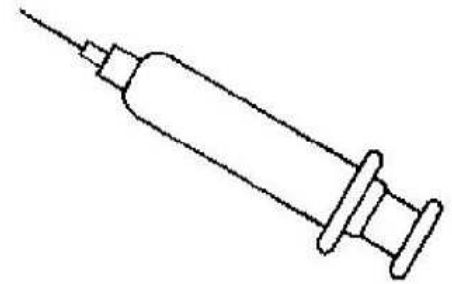
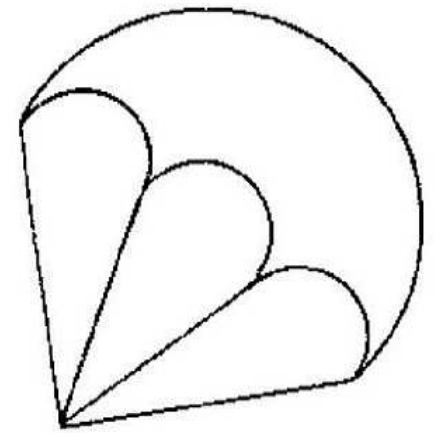

Une con una línea los dibujos que se correspondan y píntalos

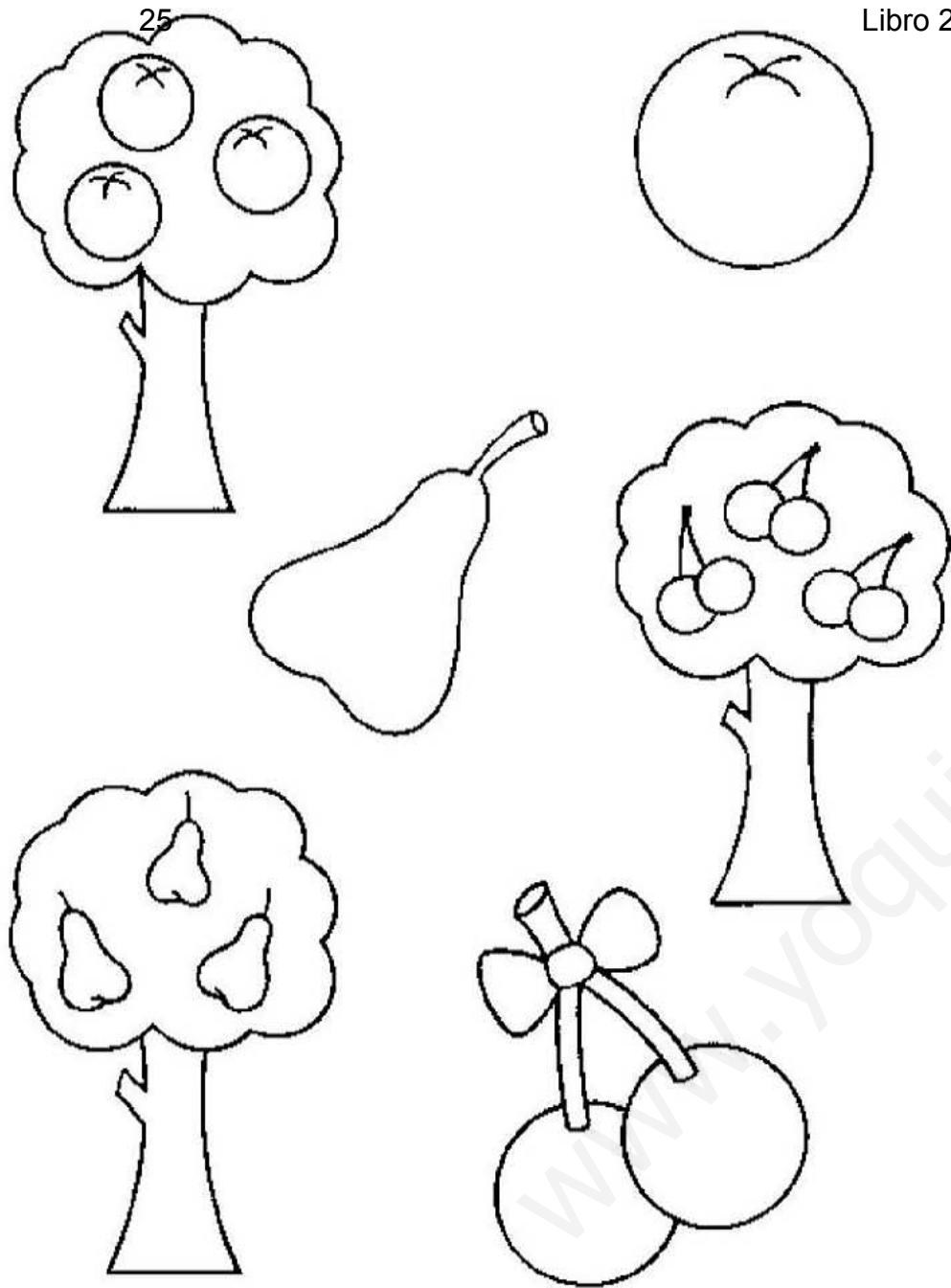

Une la fruta con el árbol que le corresponda y píntalos.

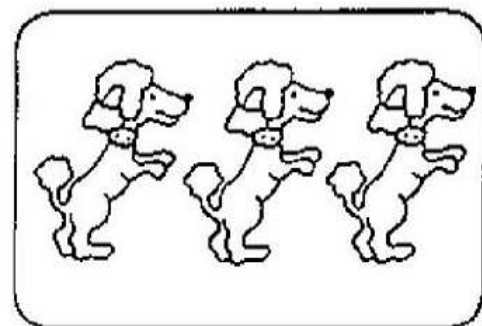
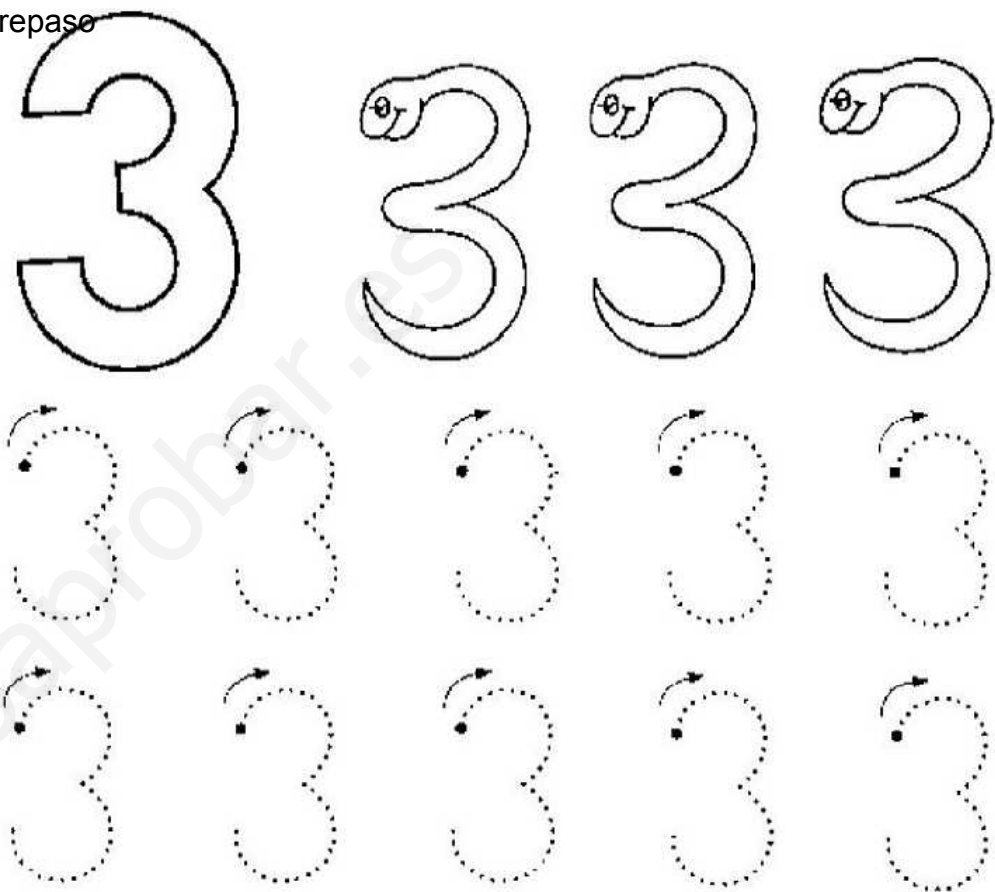

3

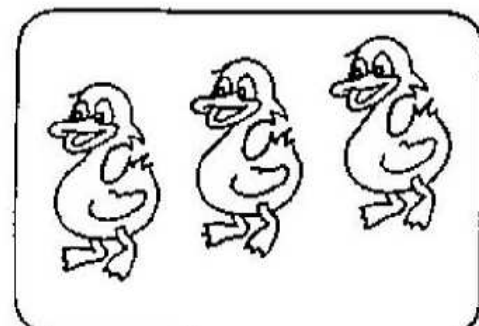

Colorea y escribe el número 3.

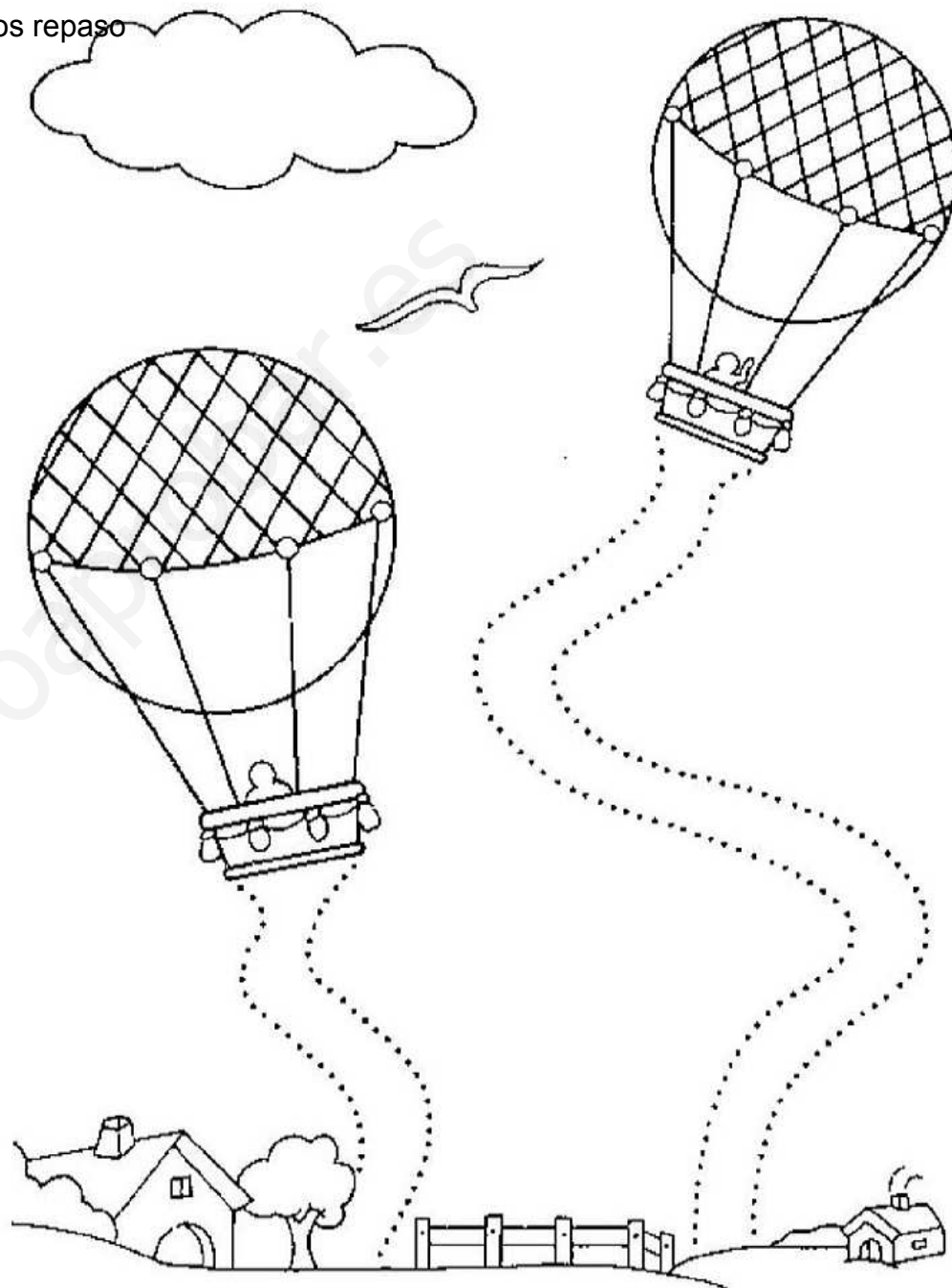
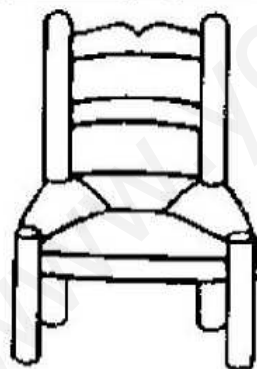
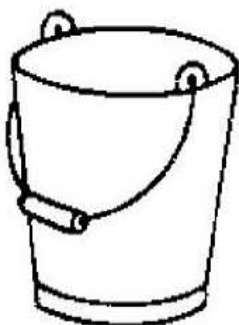
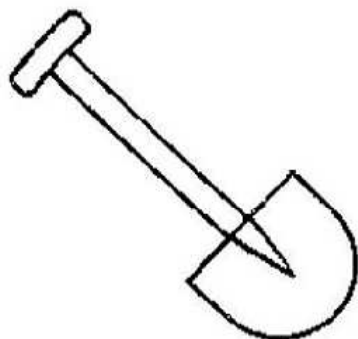
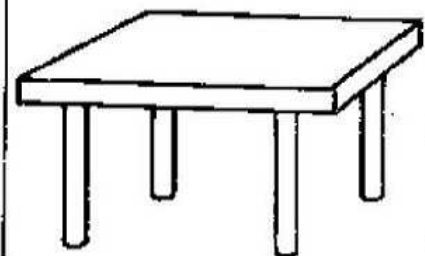

Une con una línea los objetos que tengan relación entre sí y píntalos del mismo color.

Traza en azul el trayecto largo, en amarillo el corto y colorea.

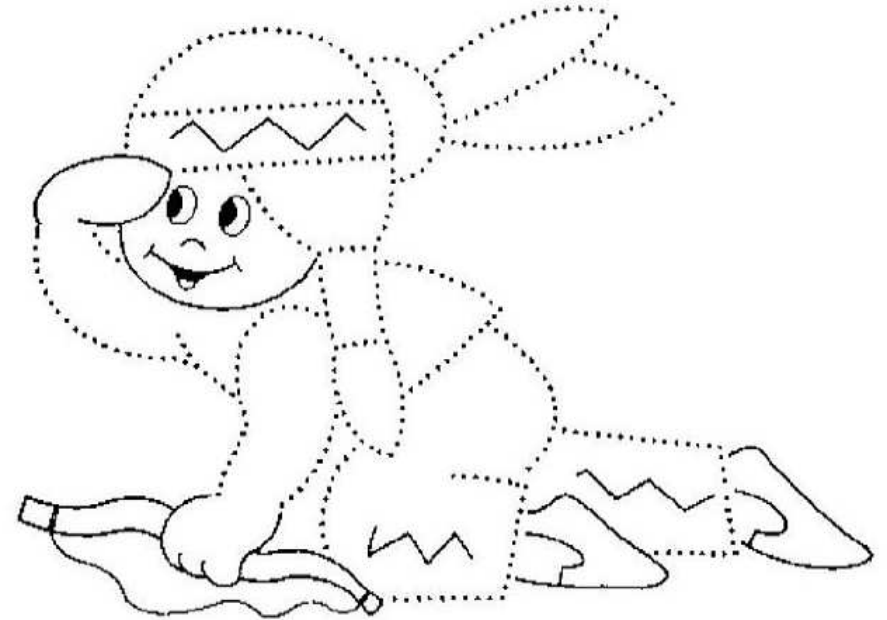
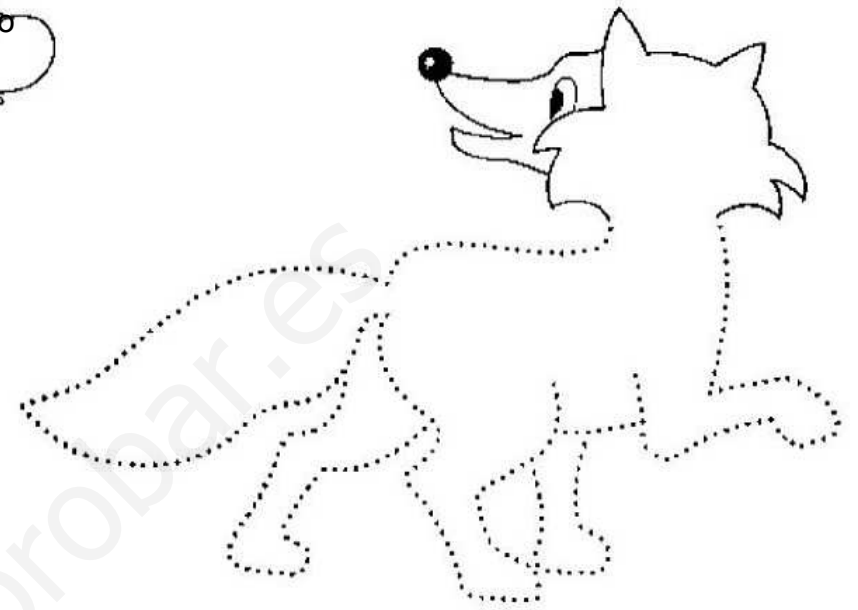
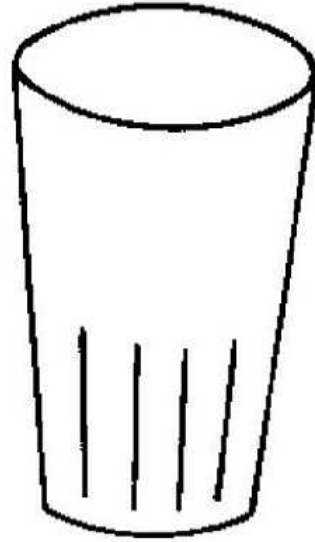
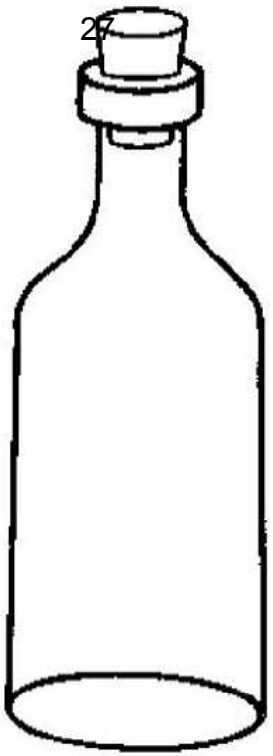

Colorea los recipientes que están vacíos.

Repasa los puntos y colorea. Rodea el de abajo.

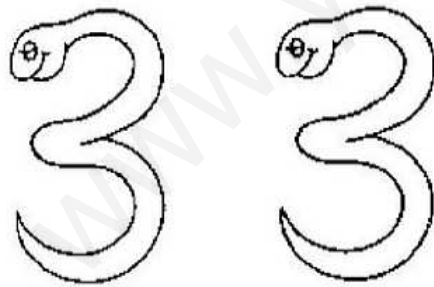
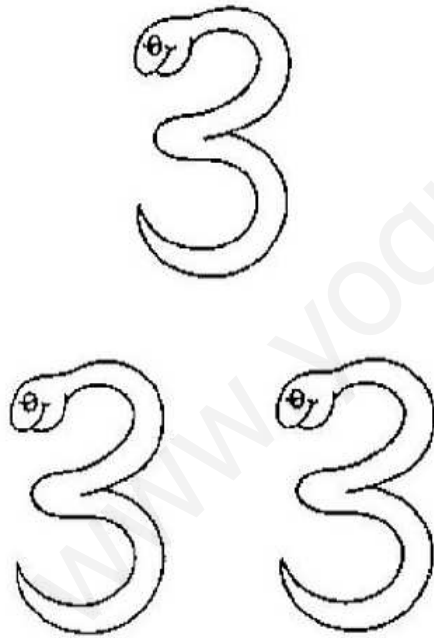
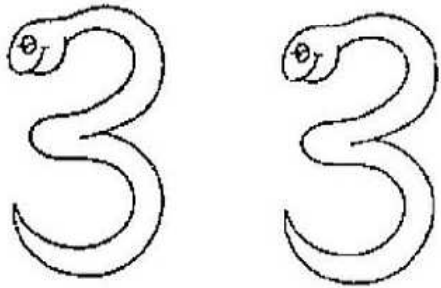
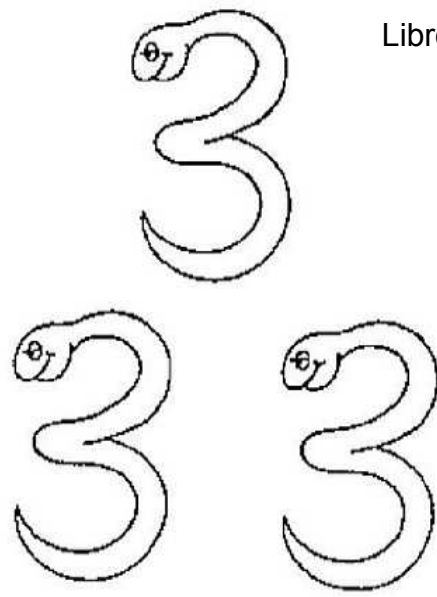

Agrupar los gusanos de 3 en 3 dentro de un contorno como la muestra y pinta los.

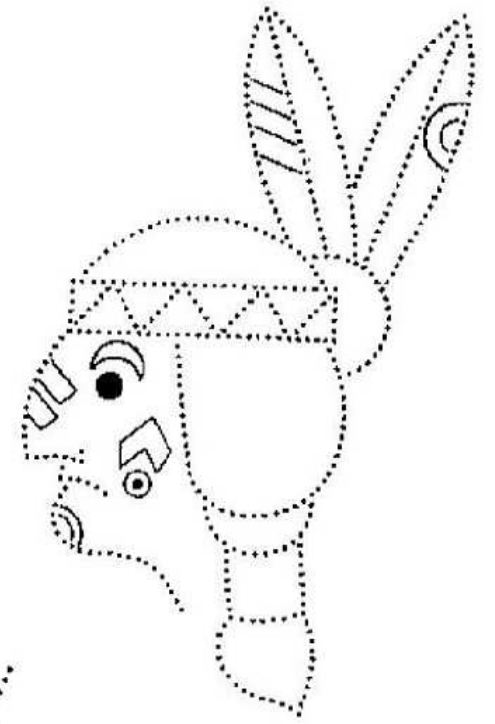
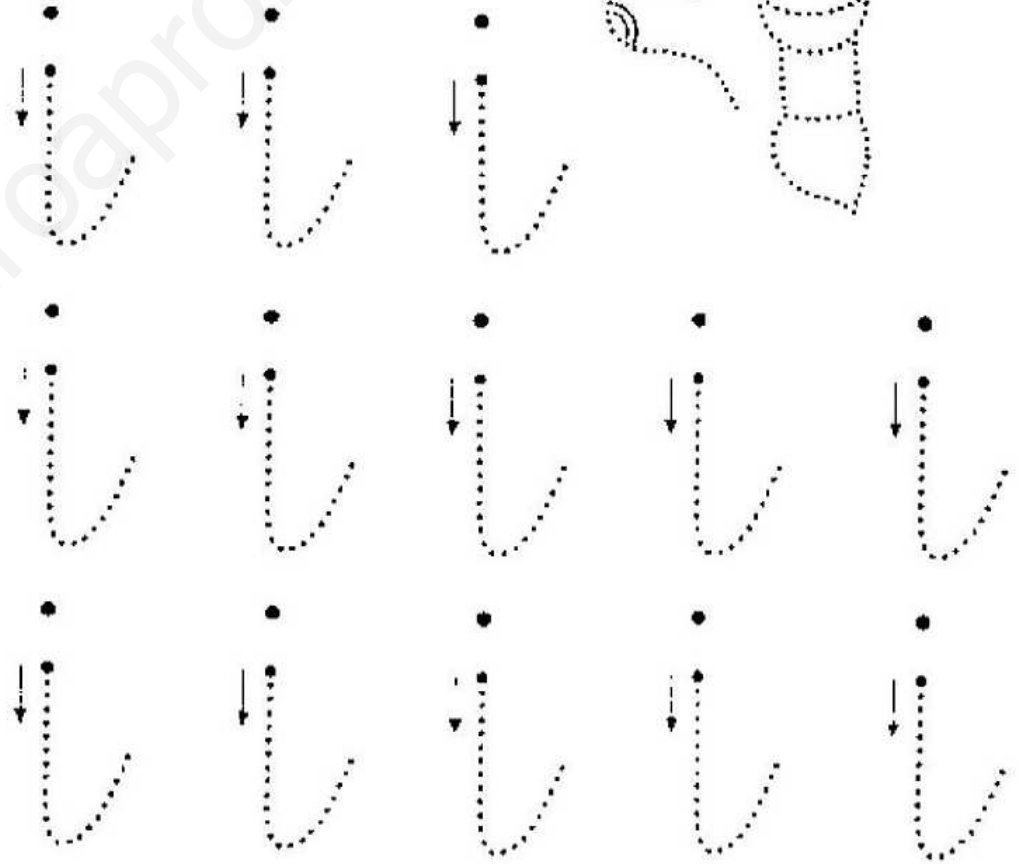
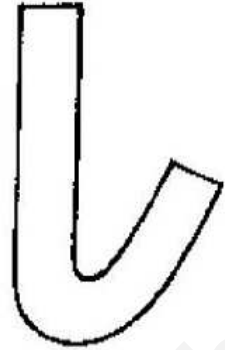

Escribe la letra i y colorea.

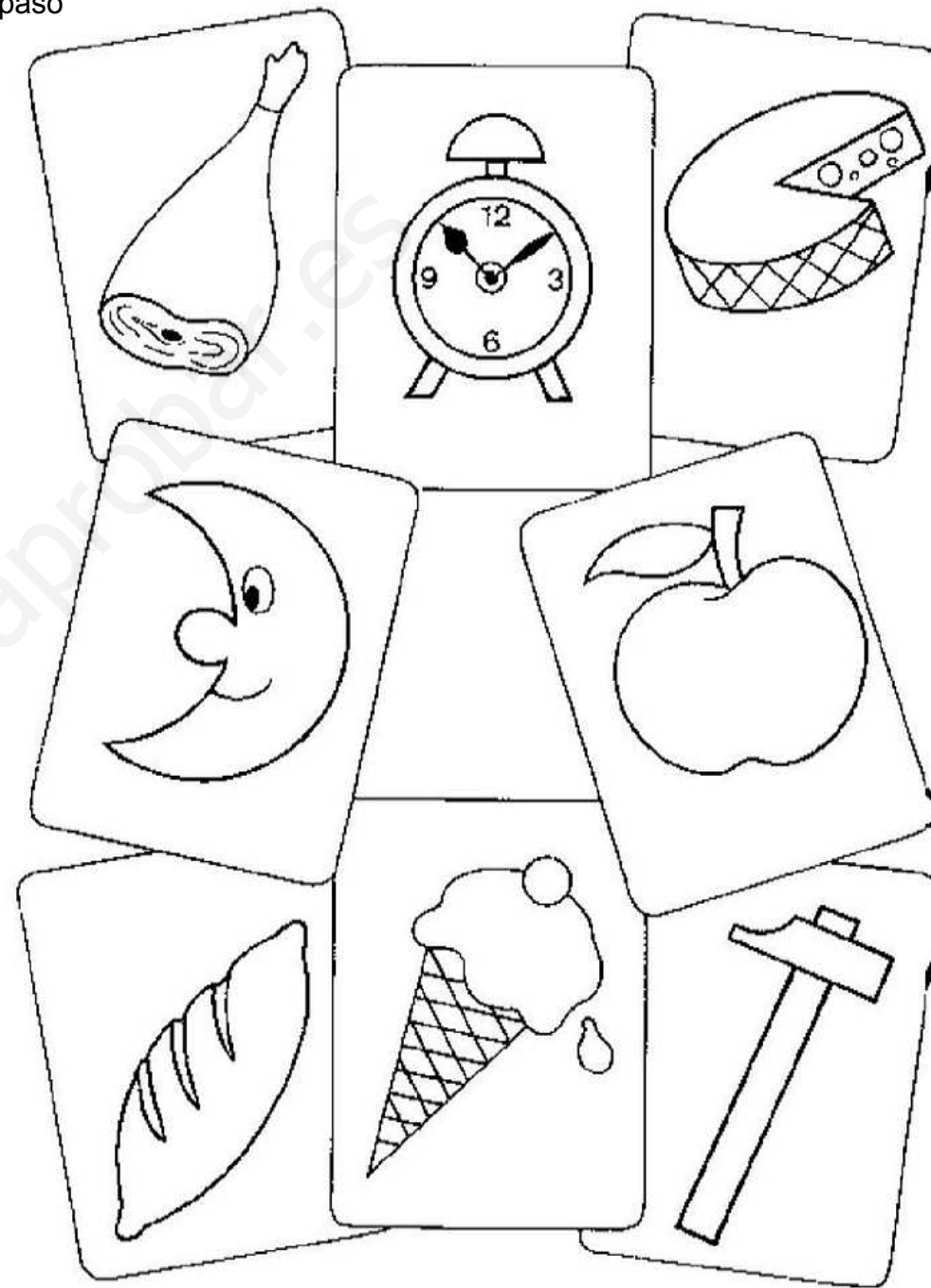
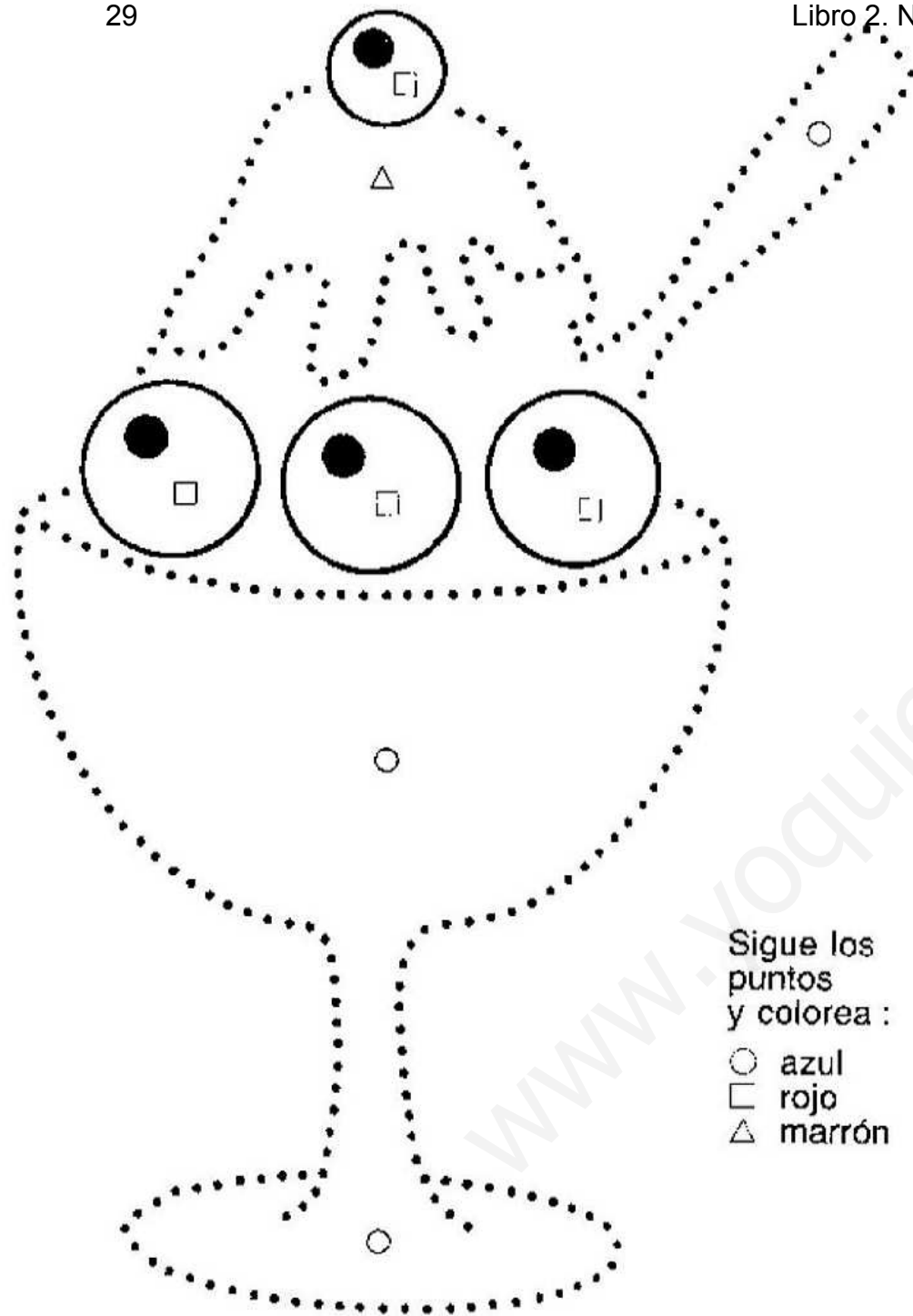

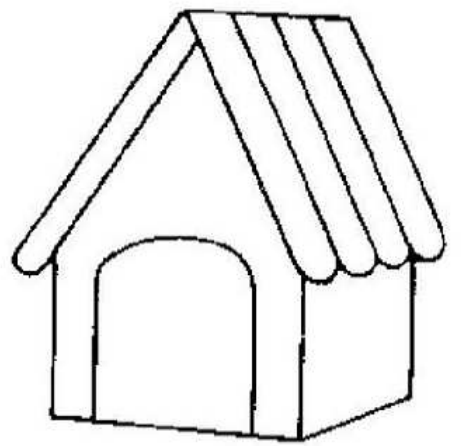
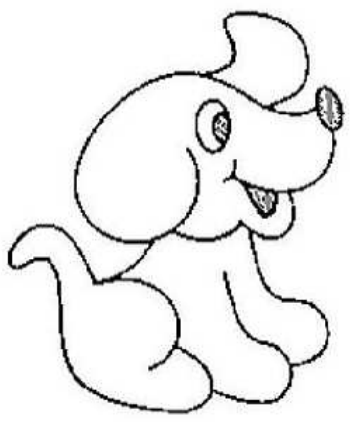
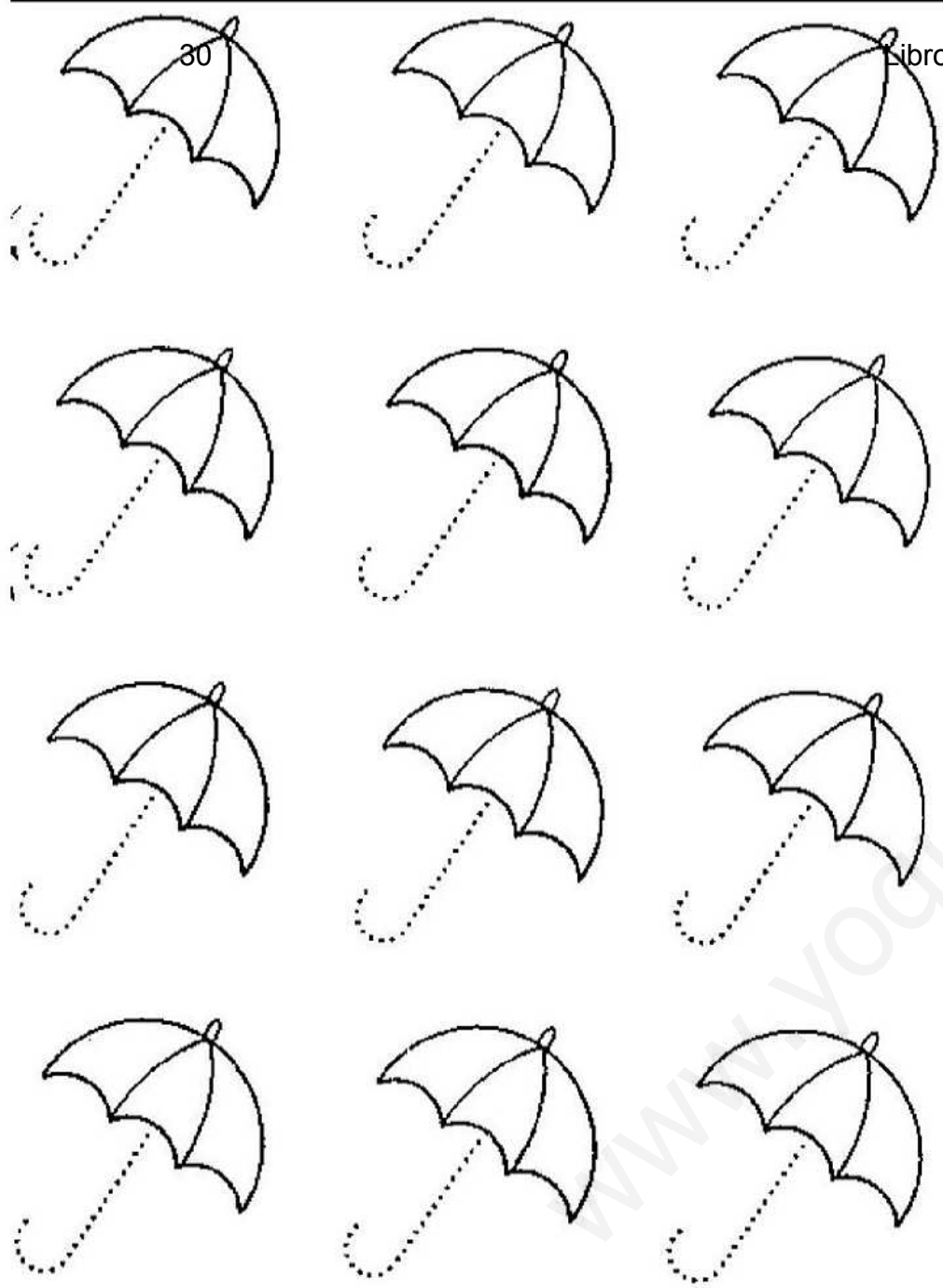

Repasa las líneas de puntos y colorea los paraguas.

Une con una línea cada perrito con la casita que le corresponda, según el tamaño, y píntalos del mismo color.

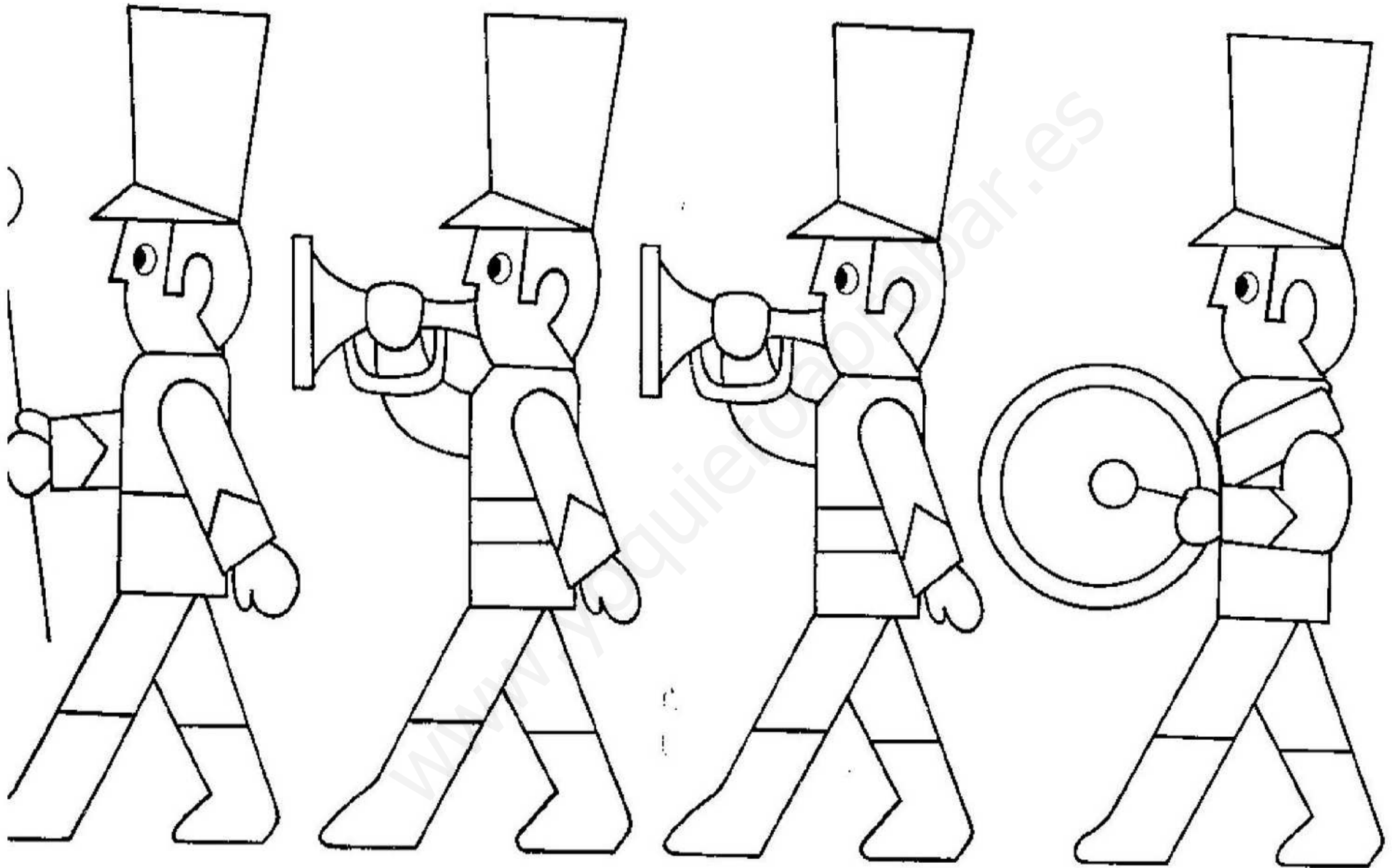

orea el músico que va el primero y repasa el que va el último.

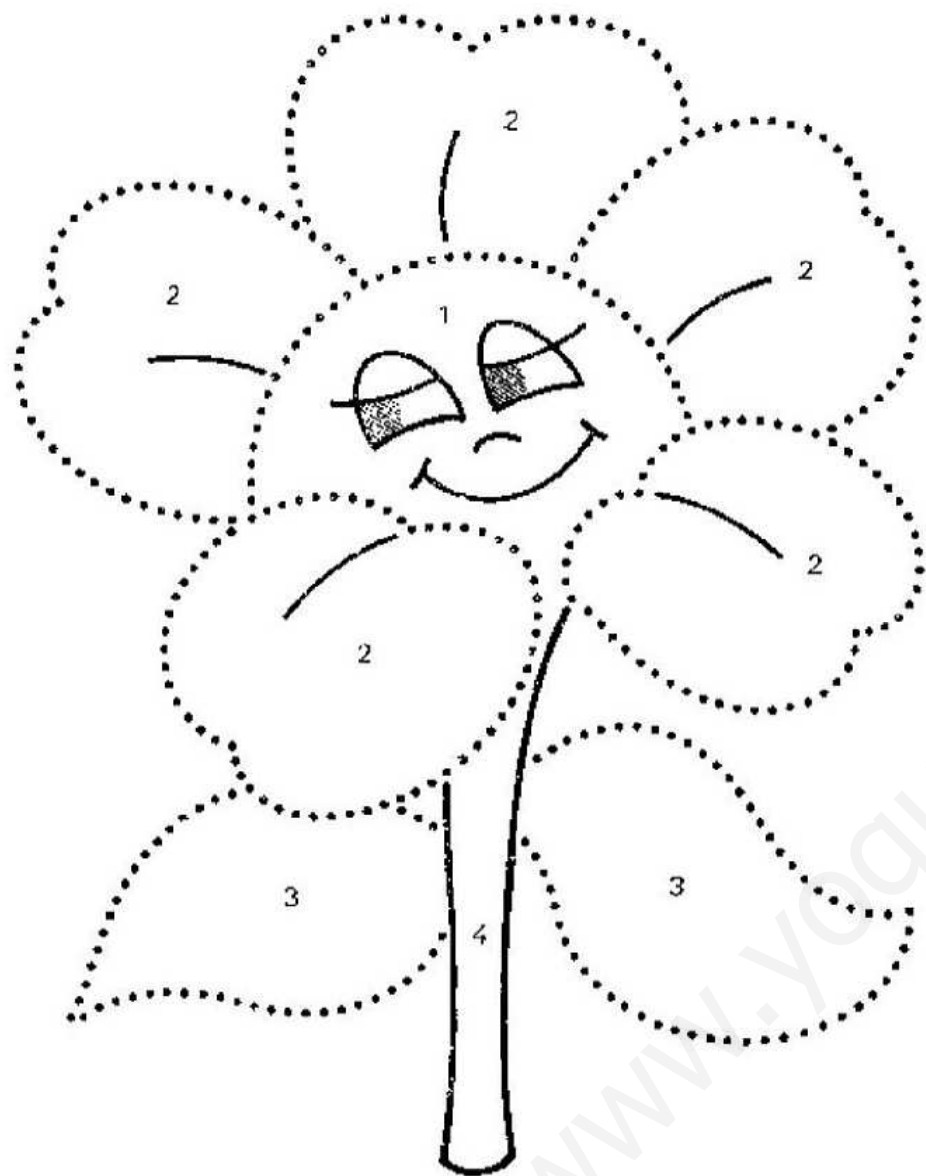

Sigue los puntos y colorea: 1 en amarillo, 2 en rojo, 3 en verde y 4 en marrón.



Colorea el niño más alto.

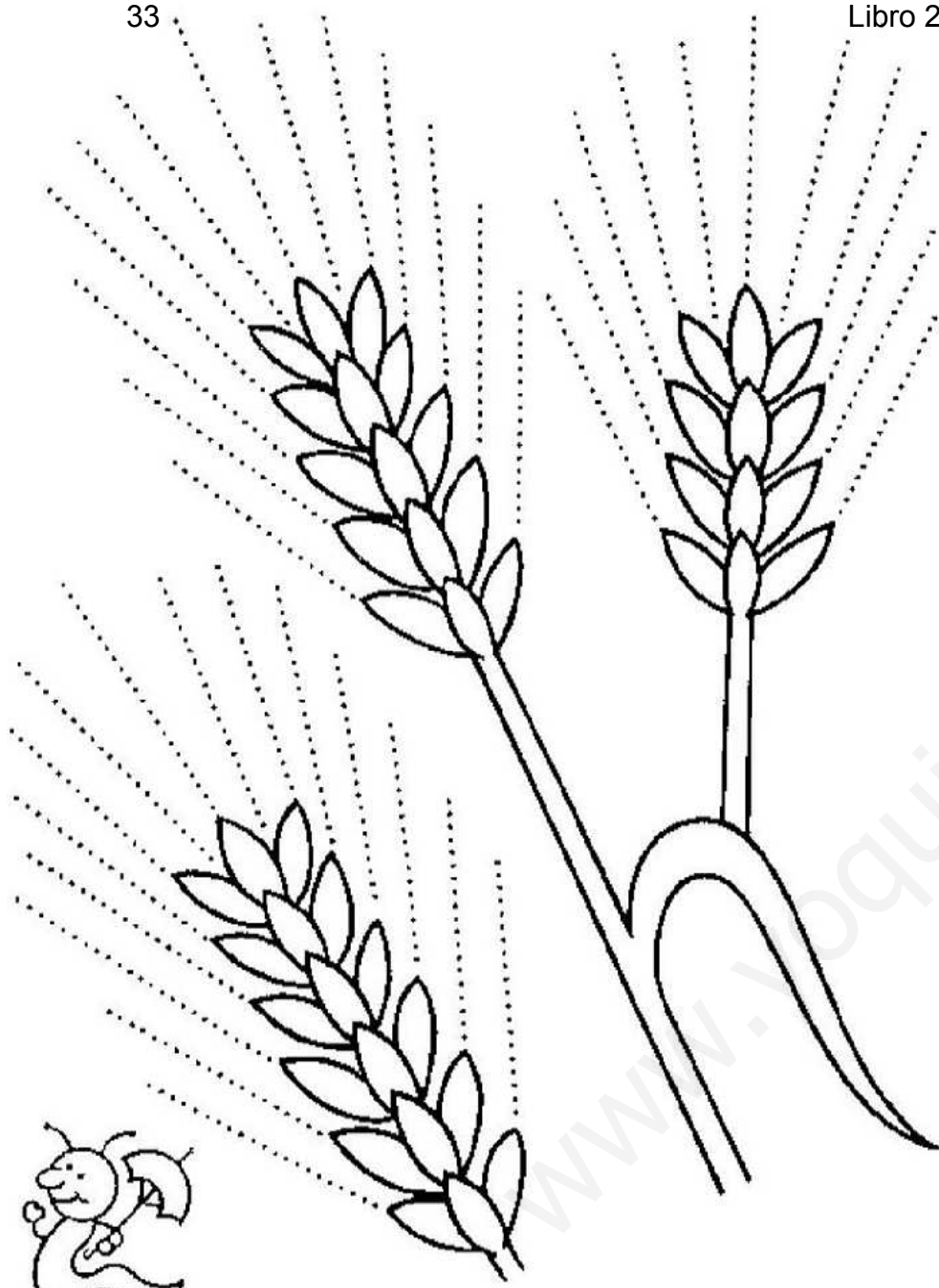

Sigue los puntos y colorea en amarillo las espigas.

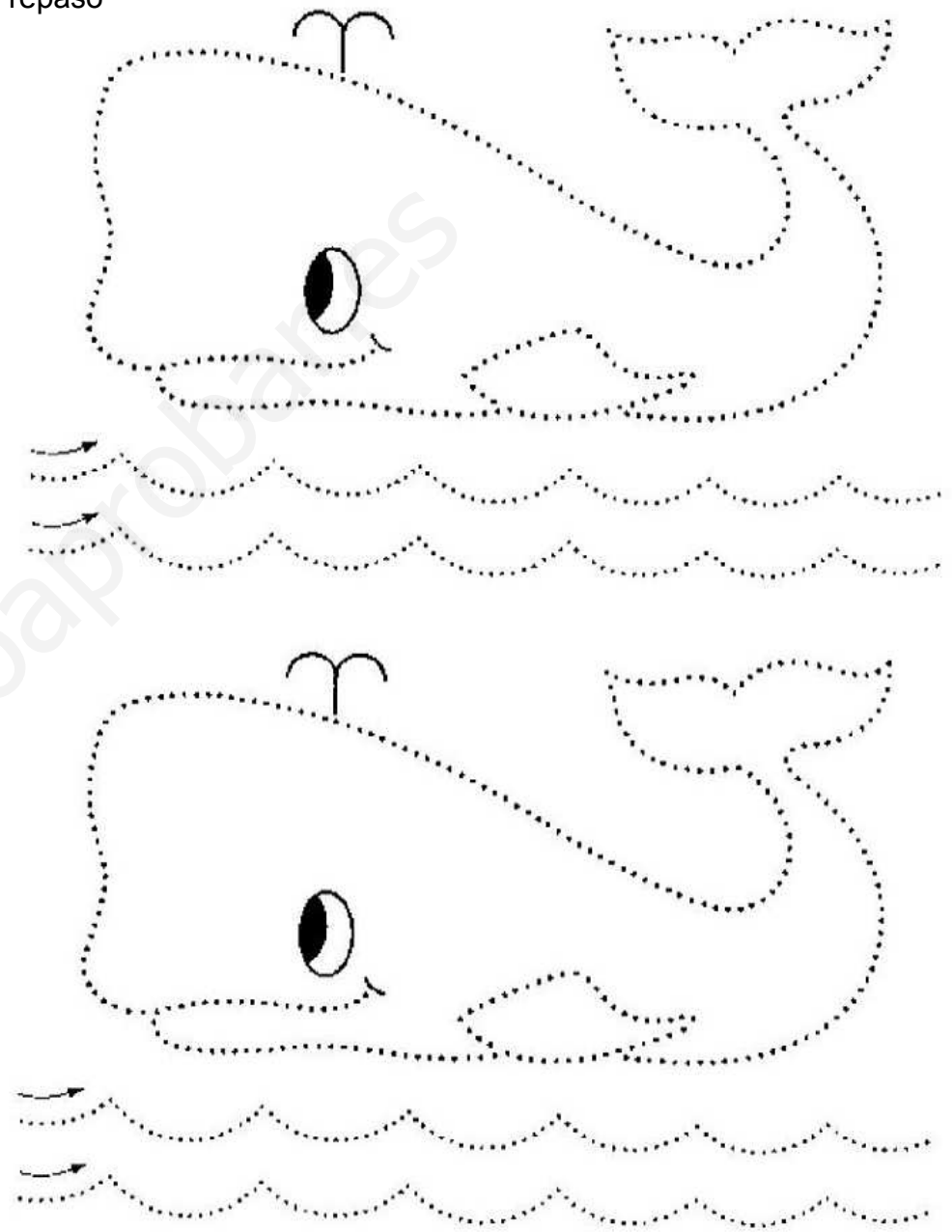

Repasa los puntos y colorea de verde la ballena de arriba y de rojo la de abajo.

Colorea el número 4.

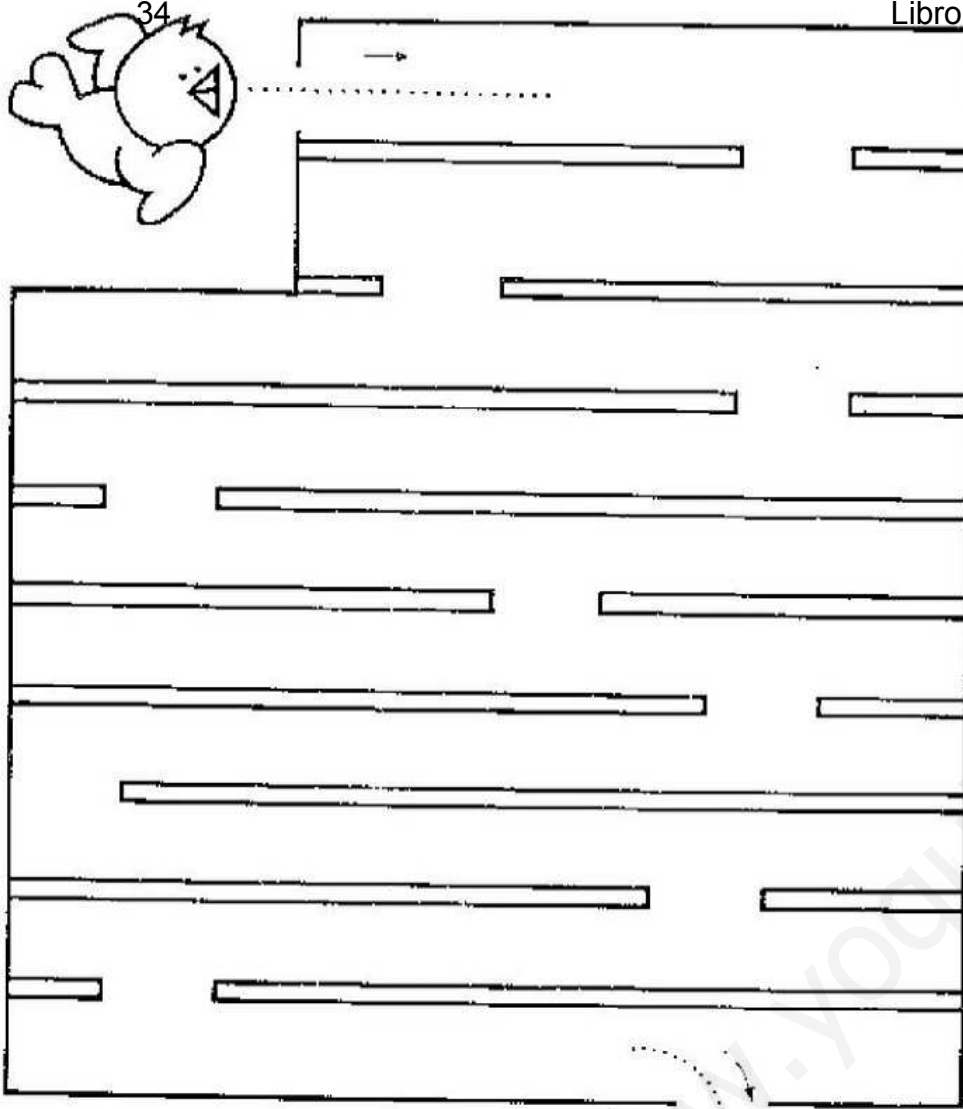

Señala el camino que seguirá el pájaro para llegar al nido y colorea.

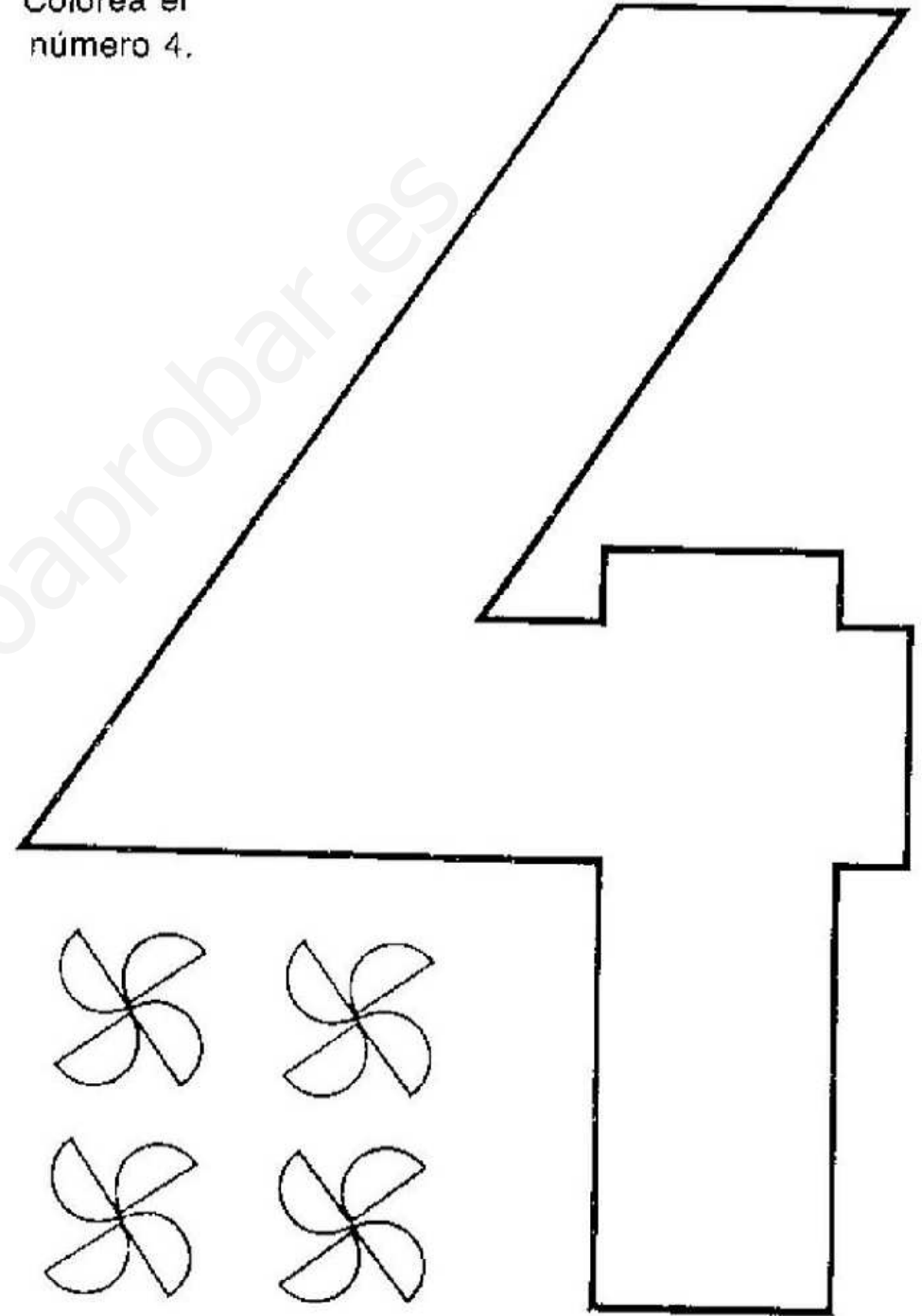
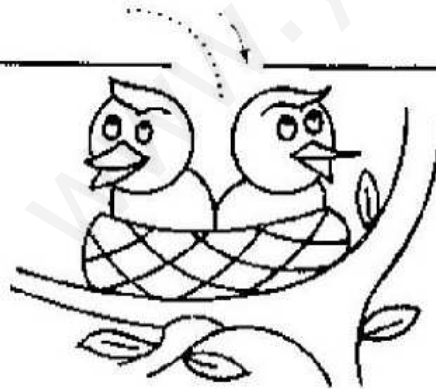

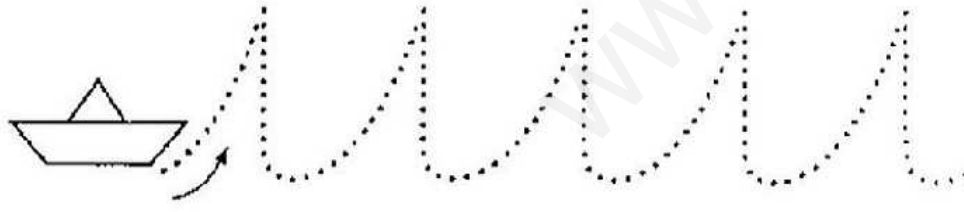
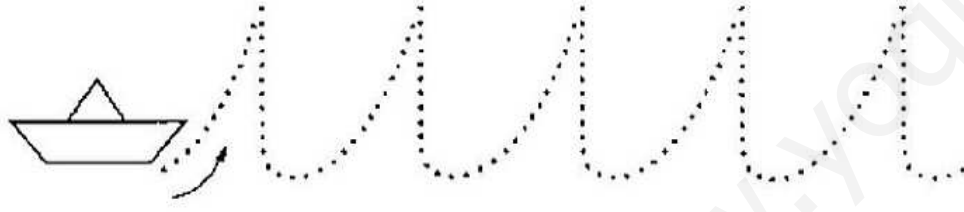
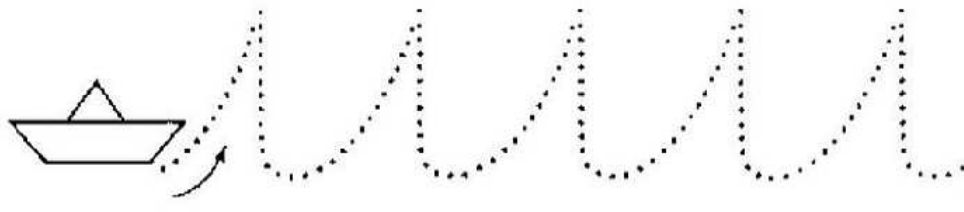
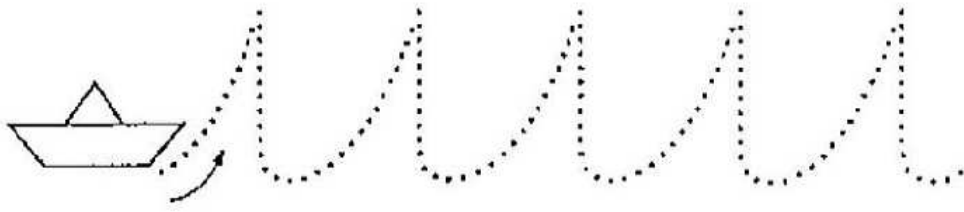
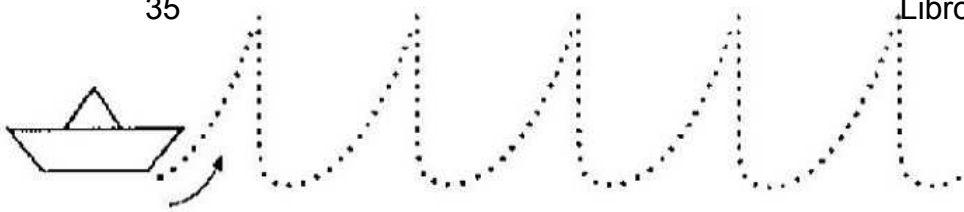

Repasa los puntos y colorea los barquitos.

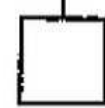
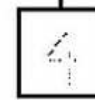
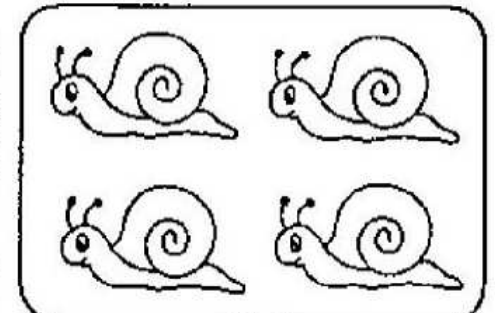
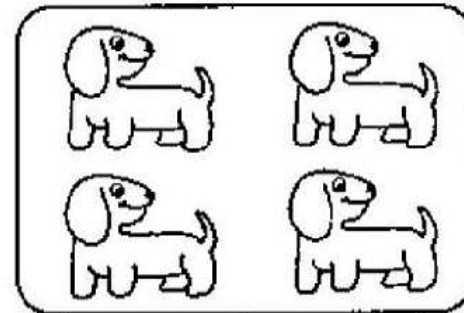
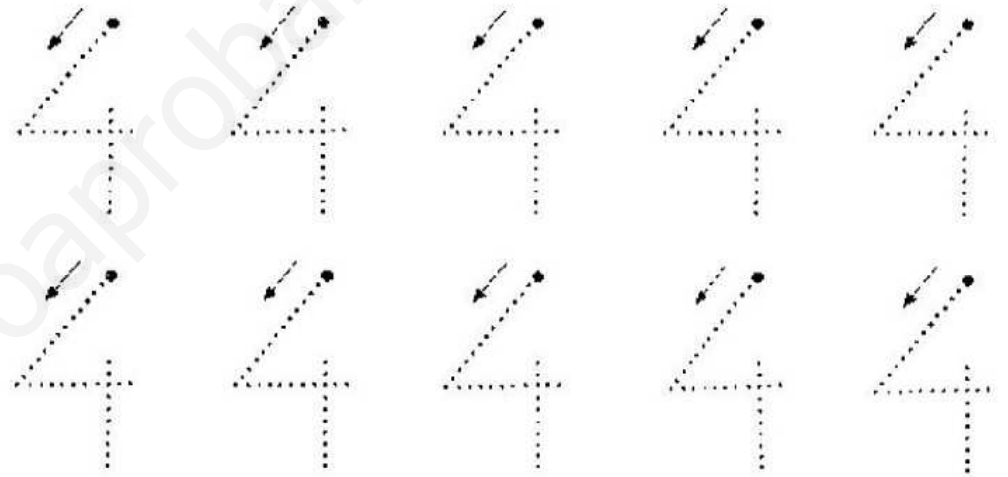
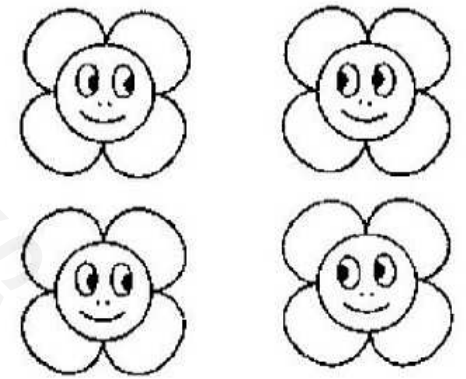
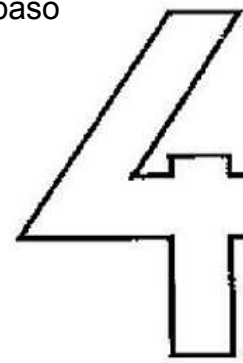

Colorea y escribe el número 4.

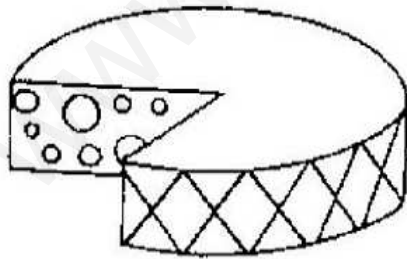
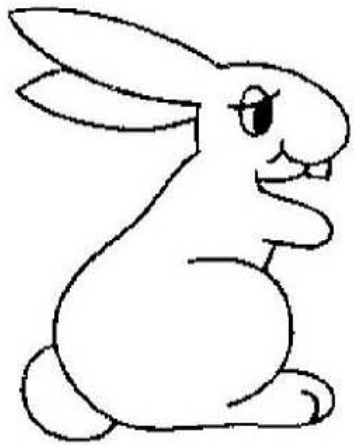
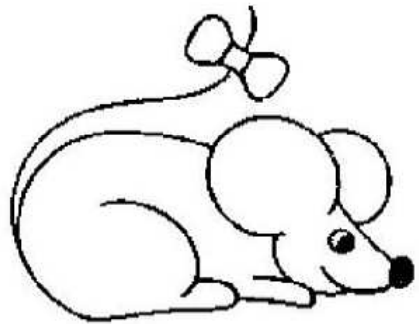
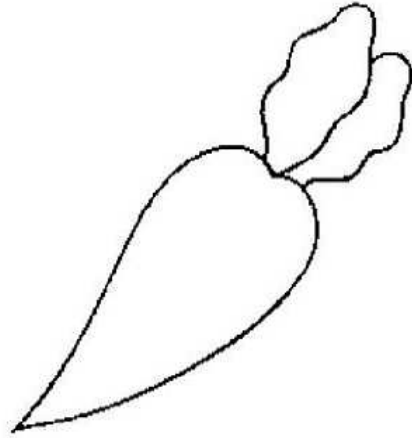

Une cada animalito con su alimento y colorea.

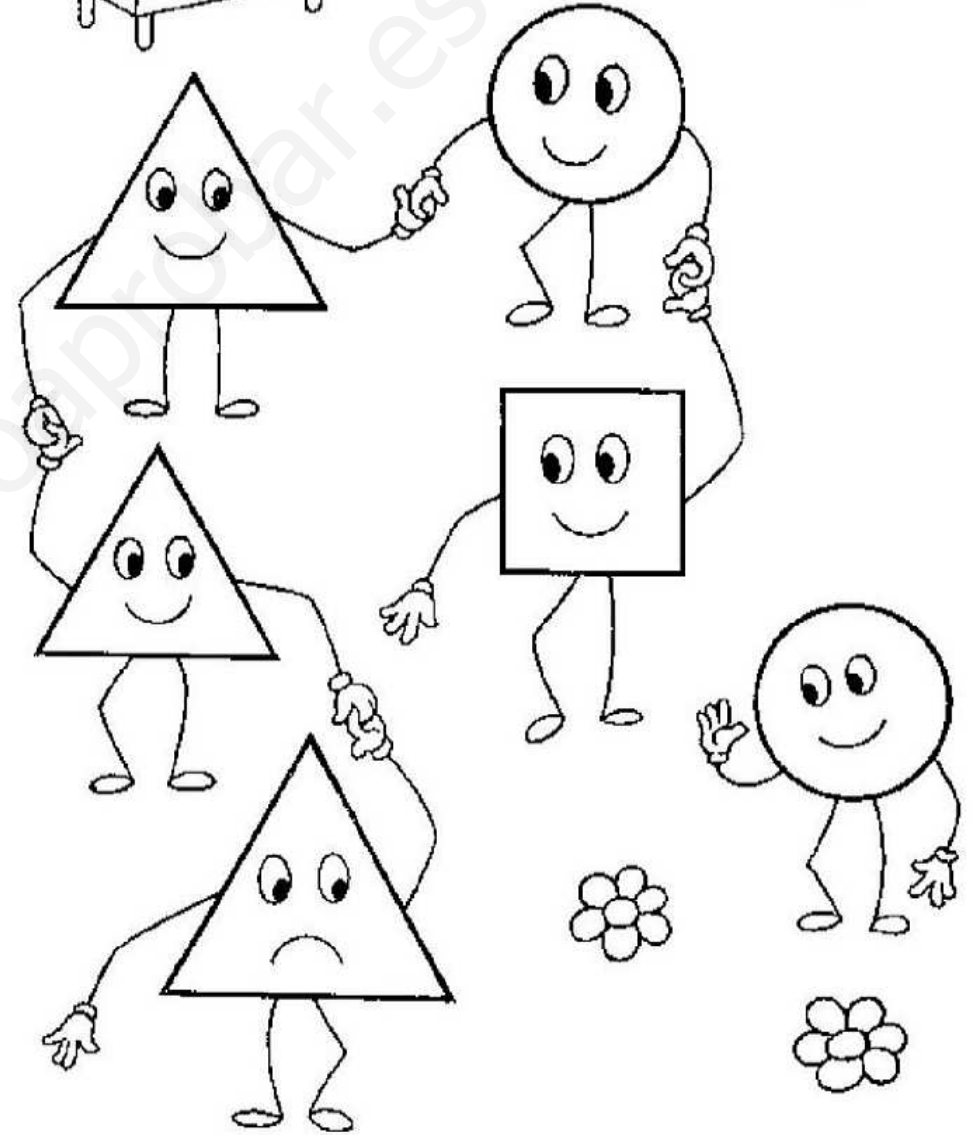
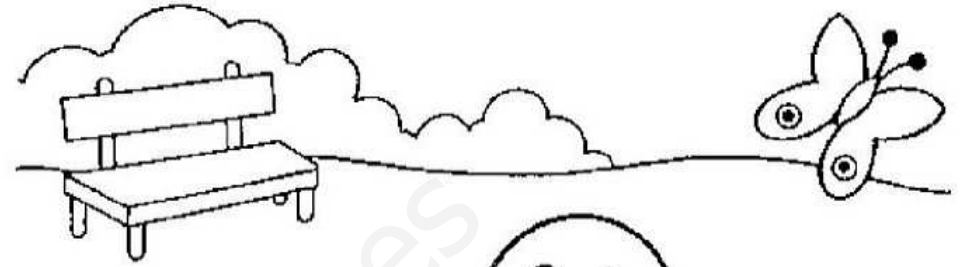

Colorea de verde los triángulos y de amarillo los círculos.

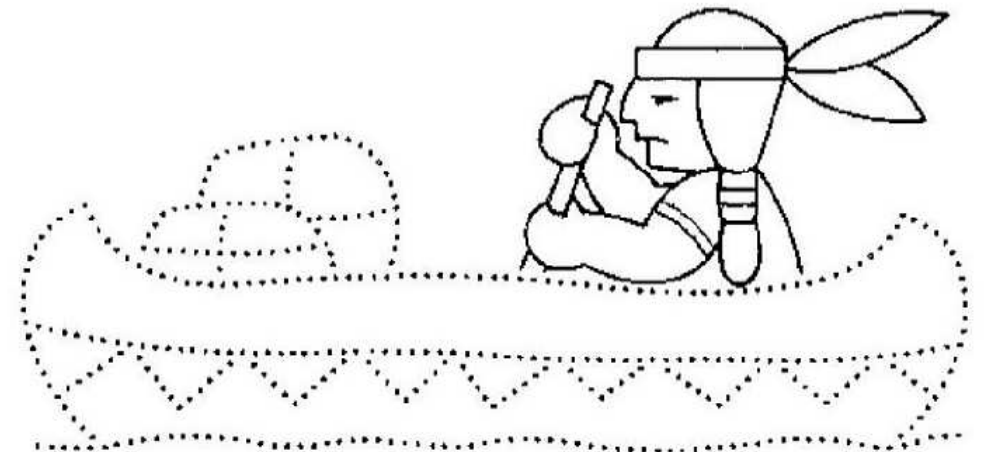
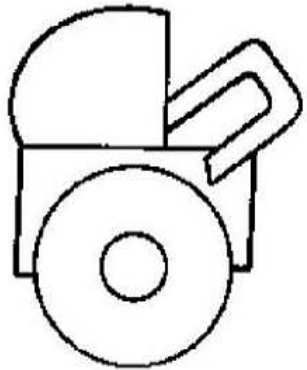
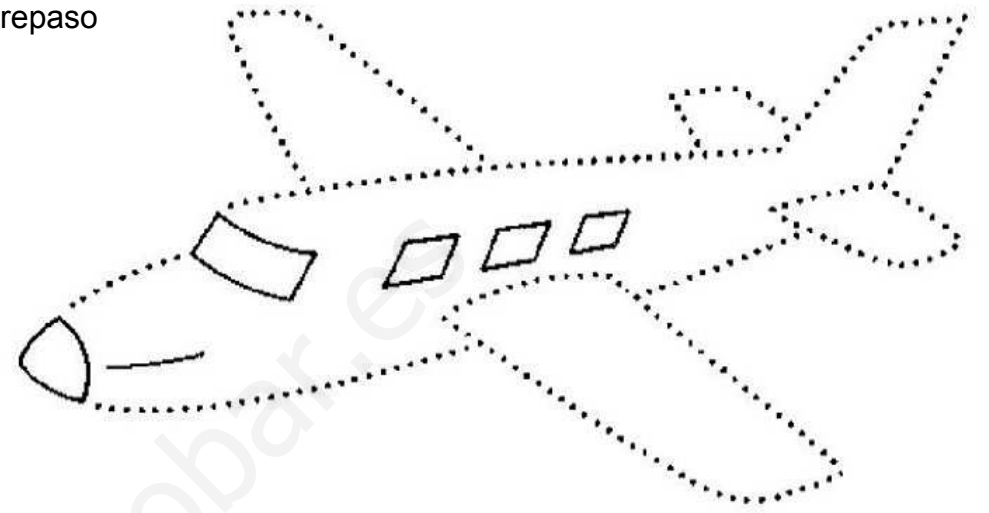
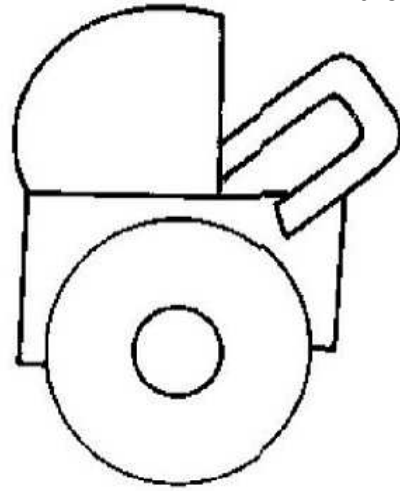

Une con una línea cada niña con su carrito según el tamaño y da color.

Repasa los puntos y colorea el que va más rápido.

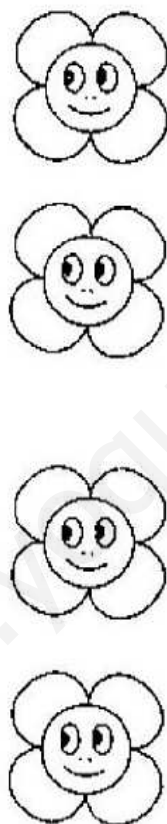
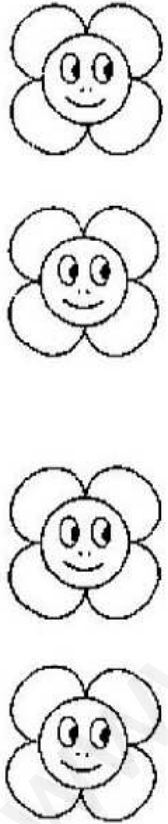
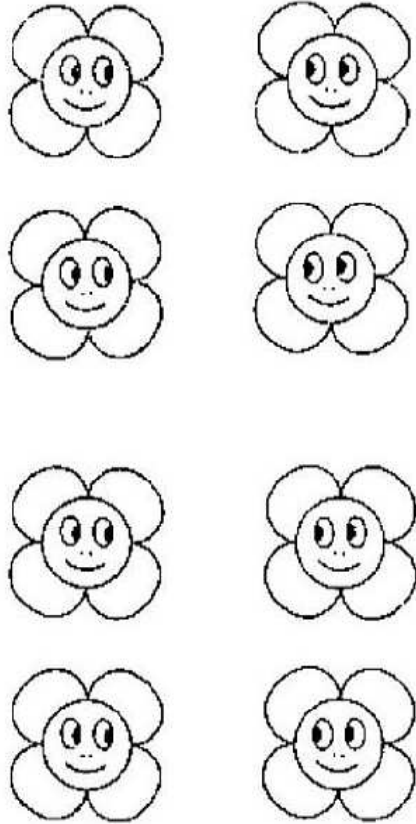
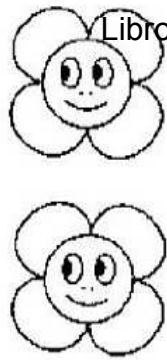
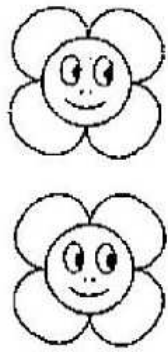
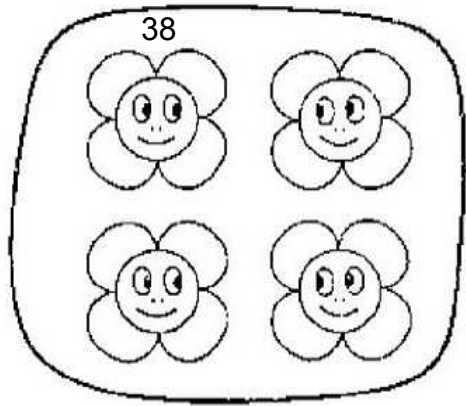

Pon las margaritas de 4 en 4 dentro de un contorno como la muestra y píntalas.

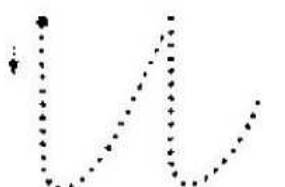
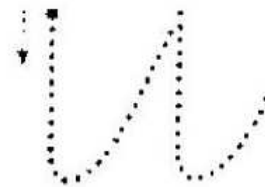
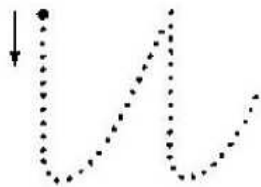
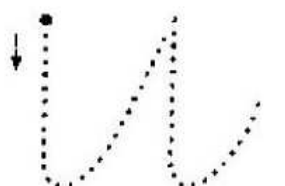
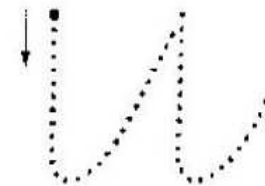
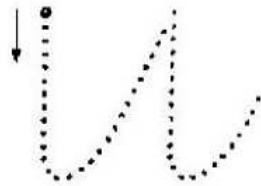
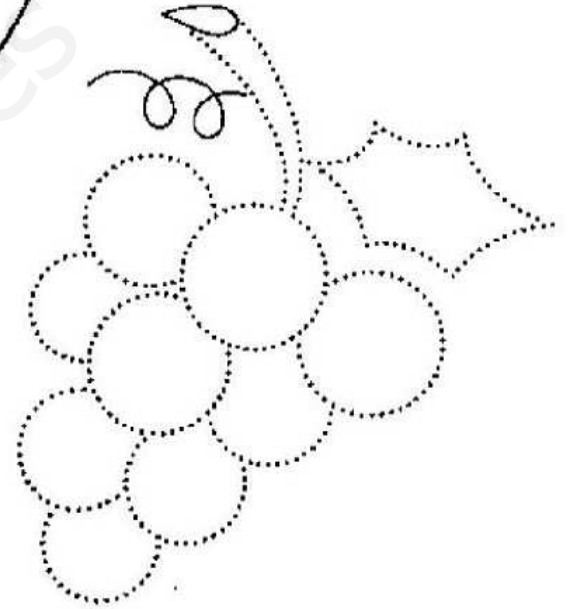
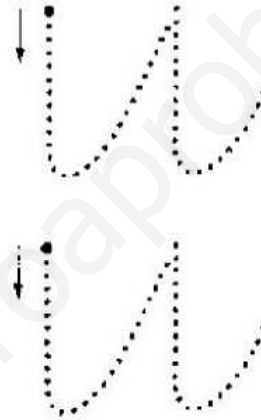
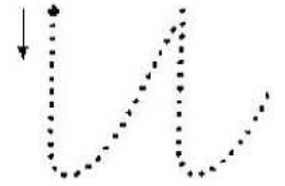
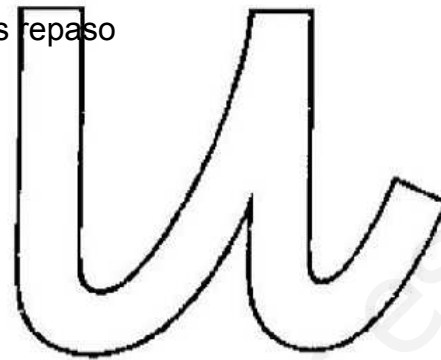

Escribe la letra u y colorea.

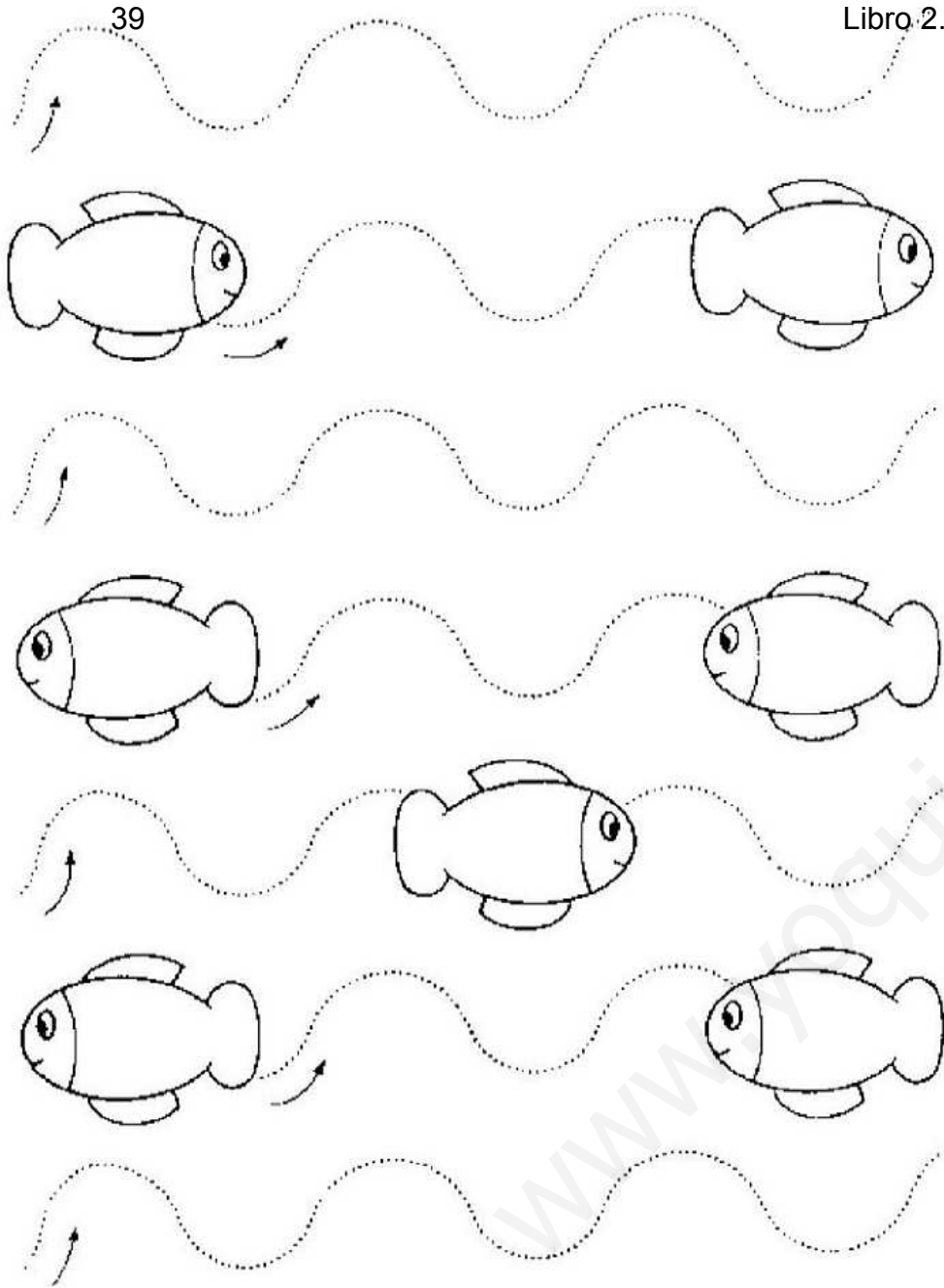

Repasa las líneas de puntos y colorea los peces.



Colorea de verde los pájaros que están cerca del espantapájaros y de amarillo los que están lejos.

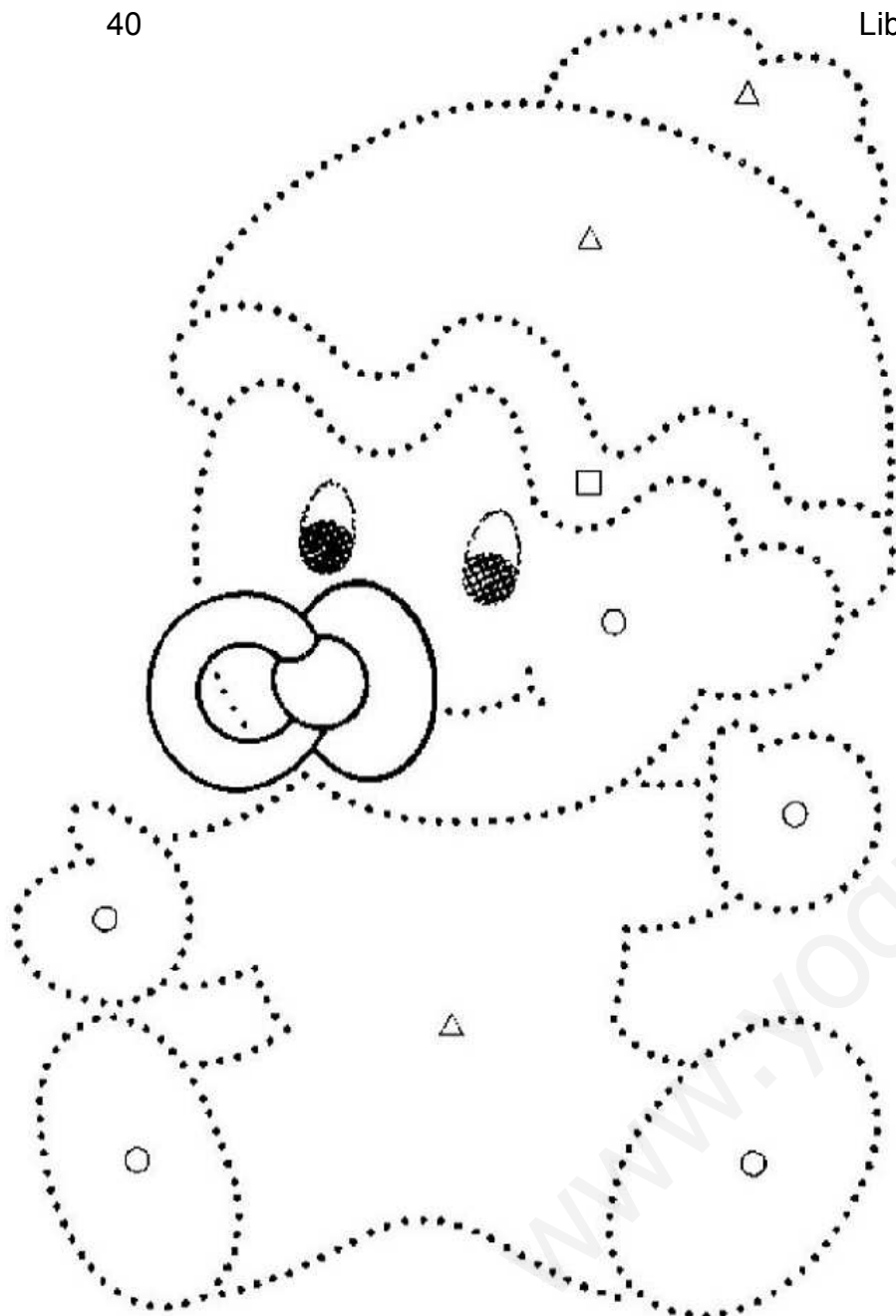

Sigue los puntos y colorea: \triangle en azul, \circ en rosa y \square en amarillo.

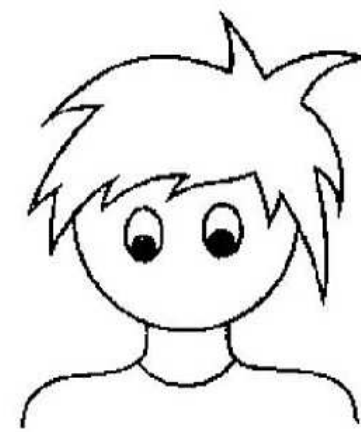
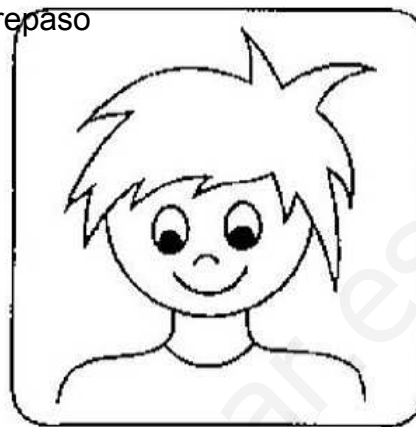

Completa las caras como la del recuadro y píntalas.

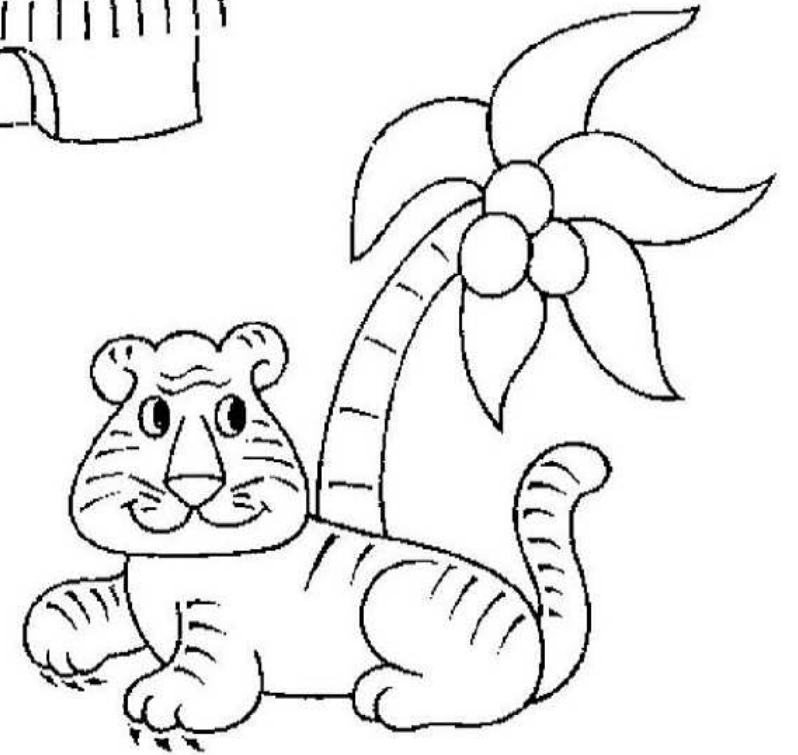
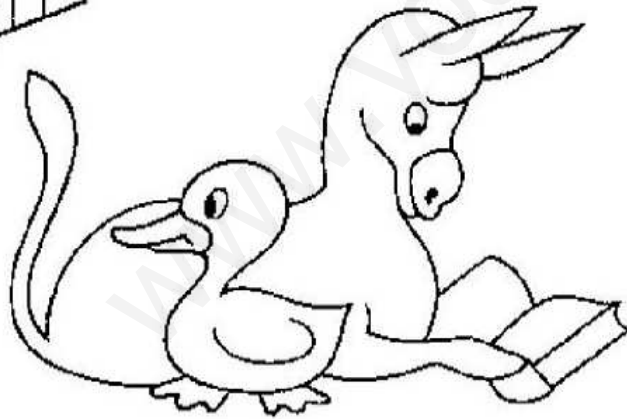
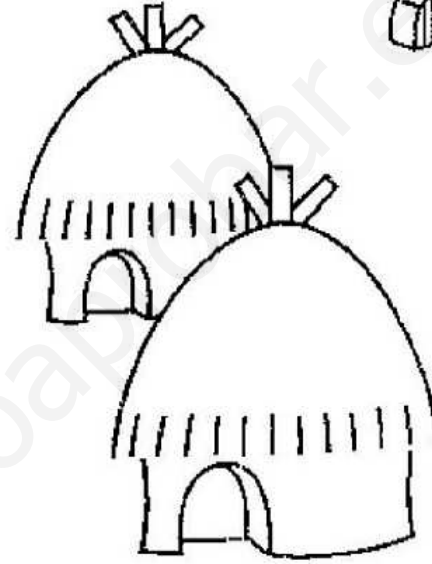
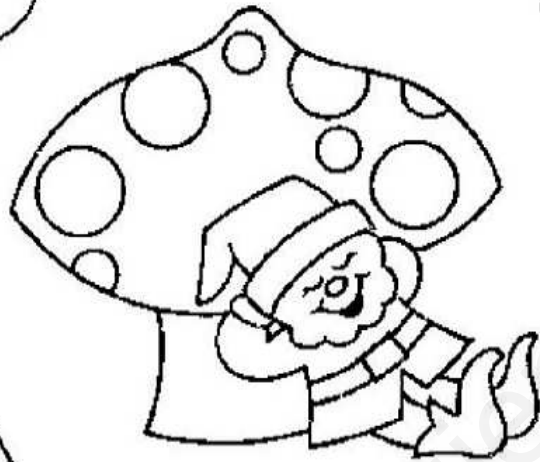

Colorea las figuras que están delante.

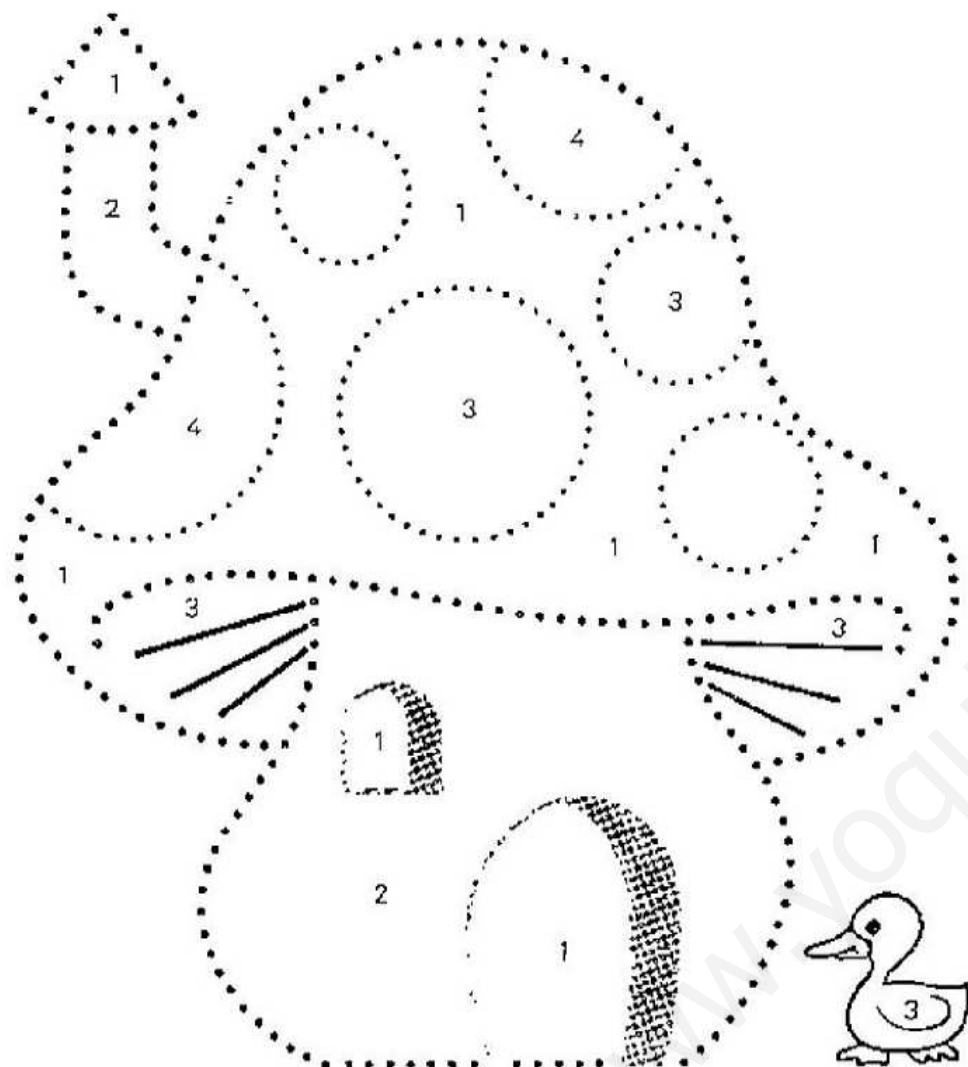

Sigue los puntos y colorea : 1 en rojo, 2 en azul, 3 en amarillo y 4 en verde.

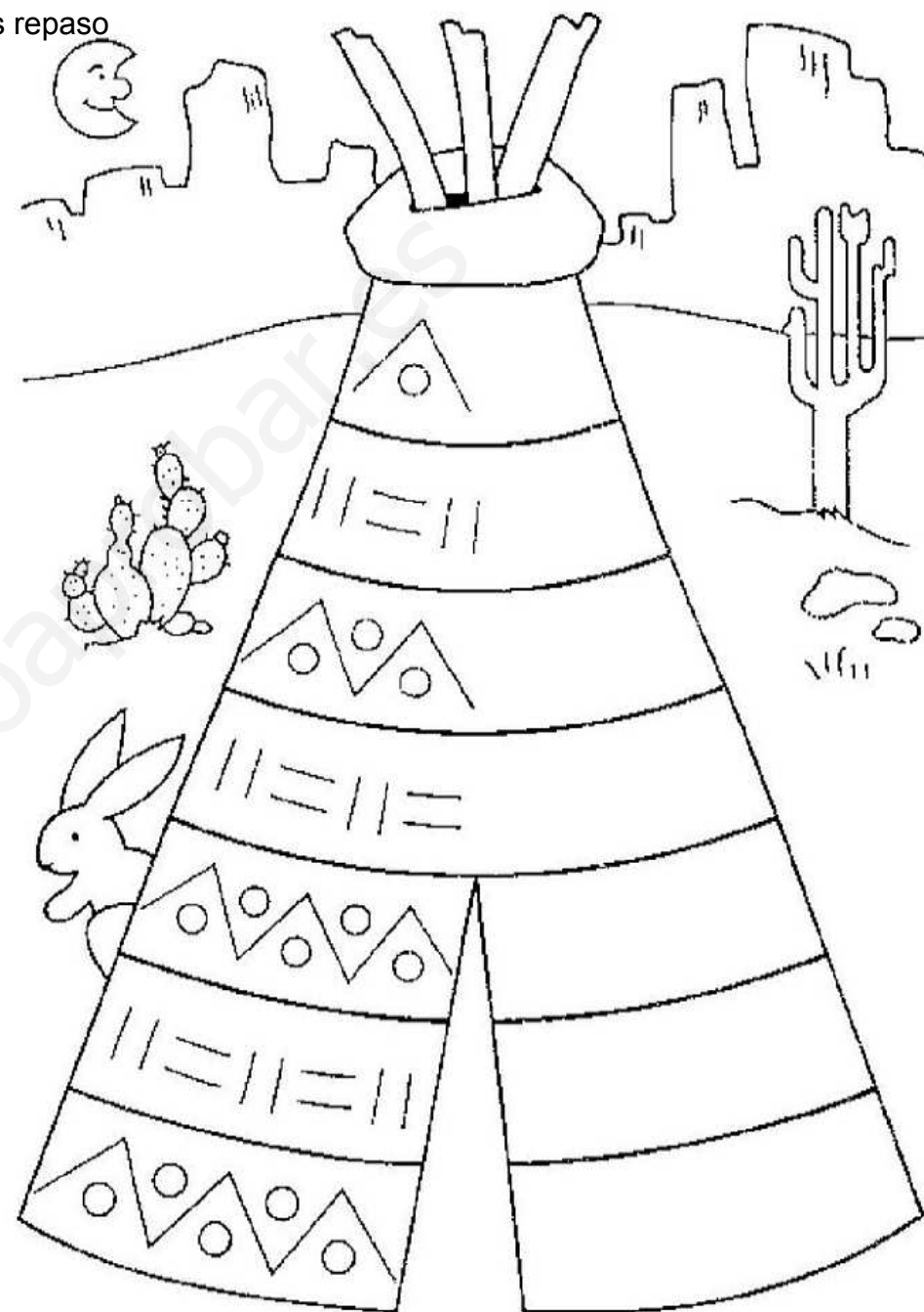

Continúa las cenefas y colorea el paisaje.

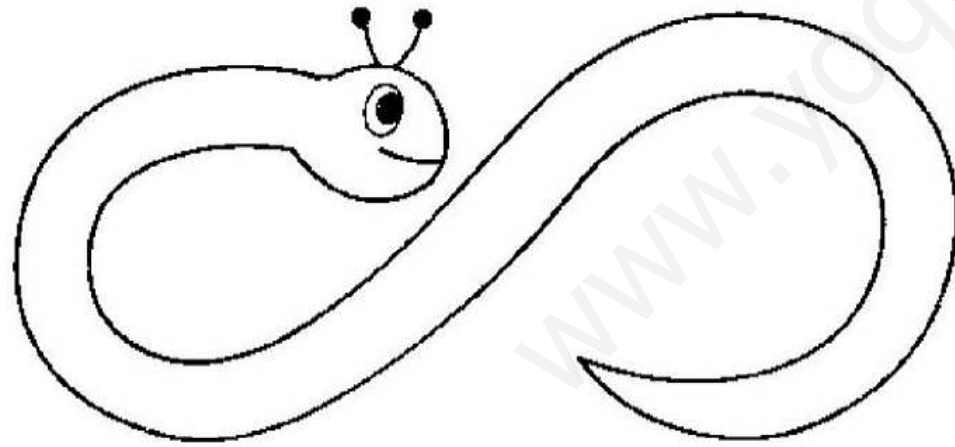
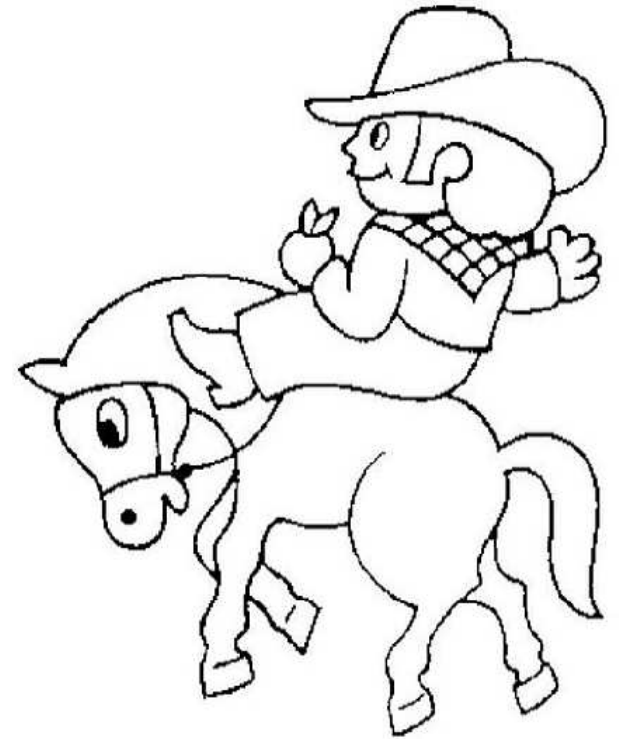
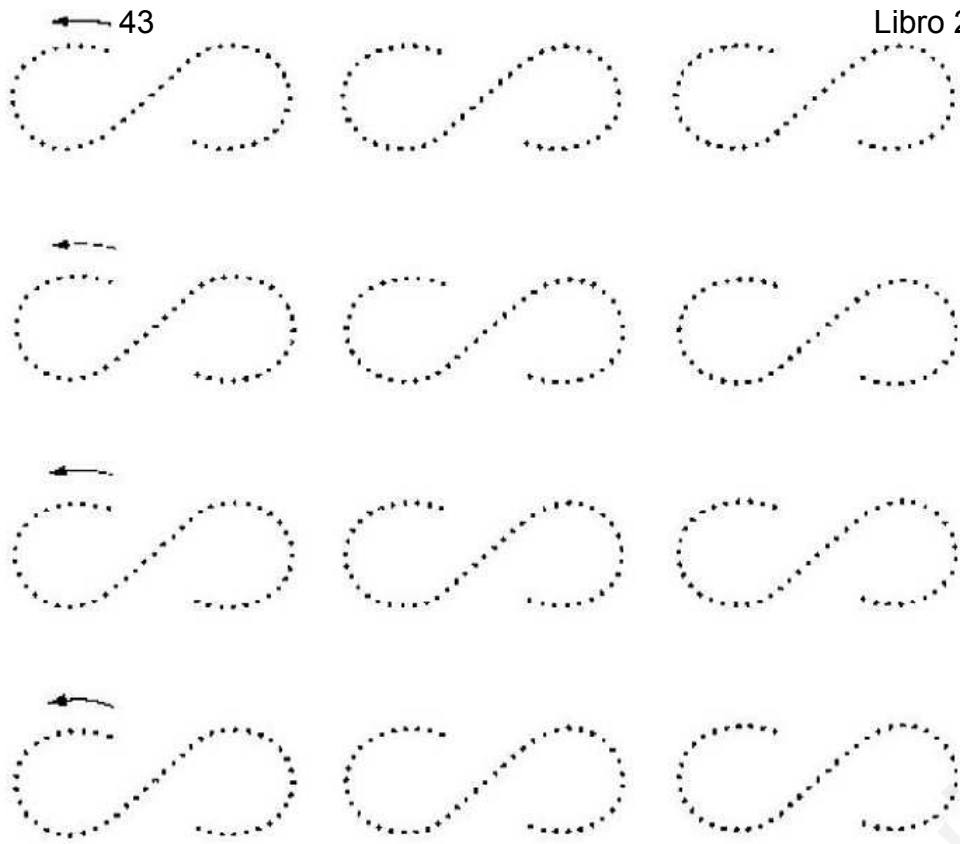

Repasa las líneas de puntos y colorea de verde el gusano.

En cada dibujo hay un personaje que está encima.
Píntalo.

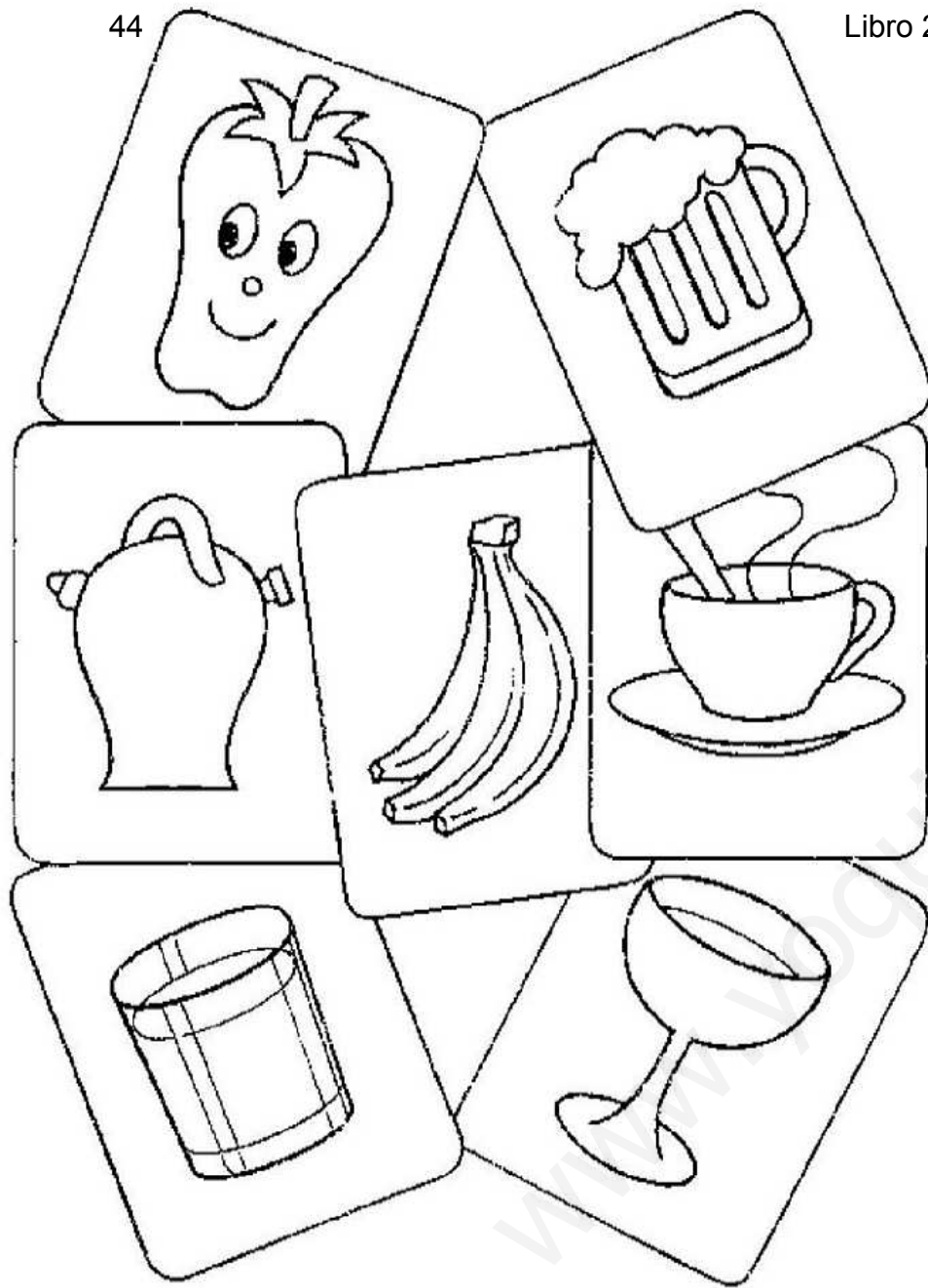

Pinta lo que sirva para beber.

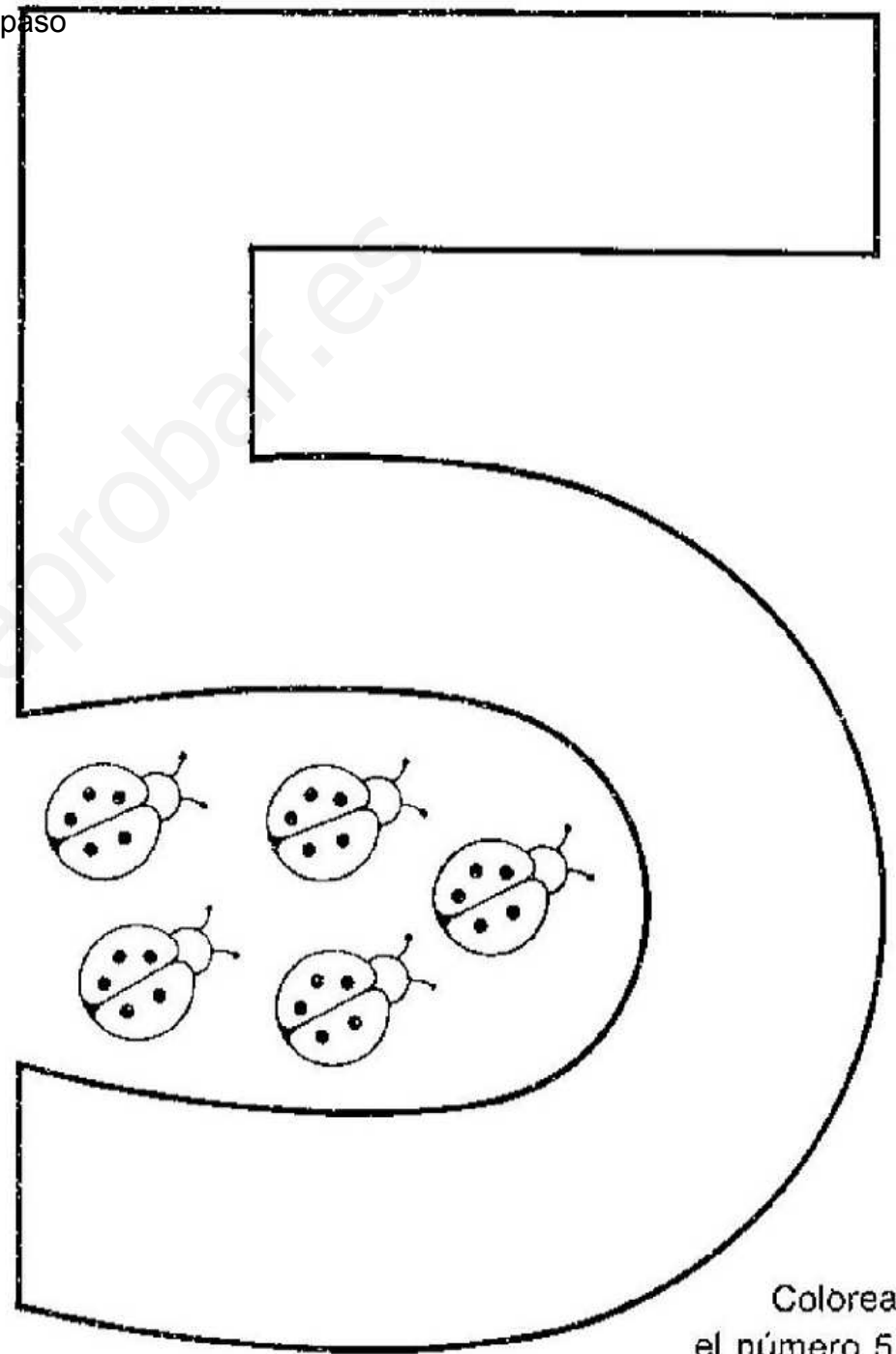

Colorea el número 5.

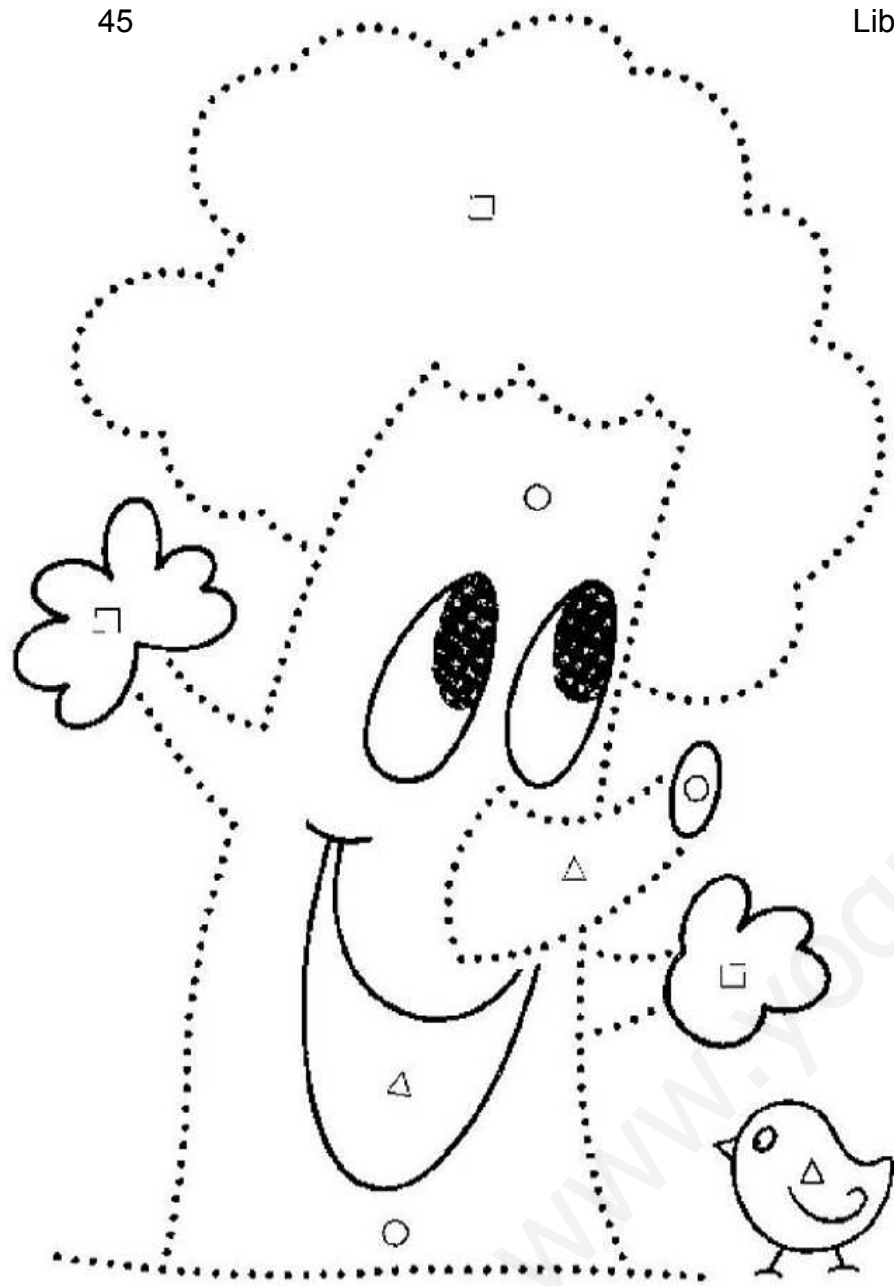

Sigue los puntos y colorea: □ en verde, ○ en marrón y △ en naranja.

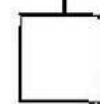
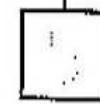
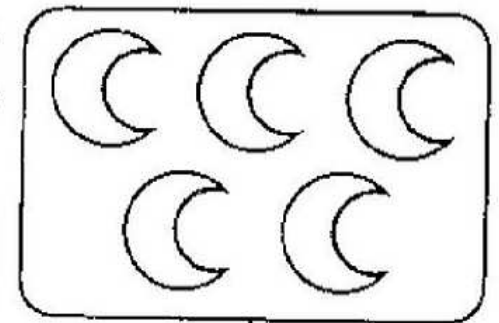
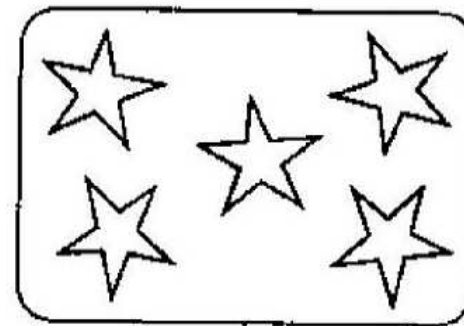
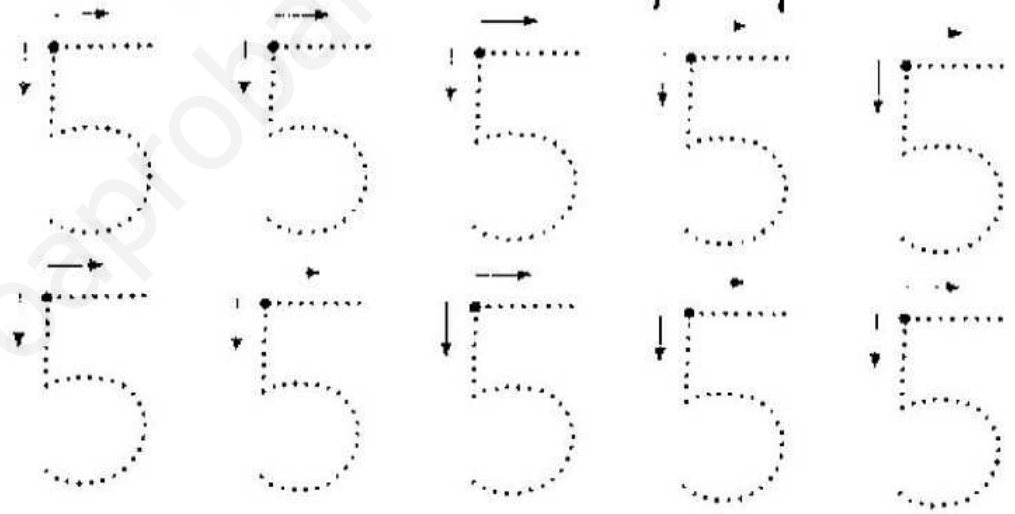
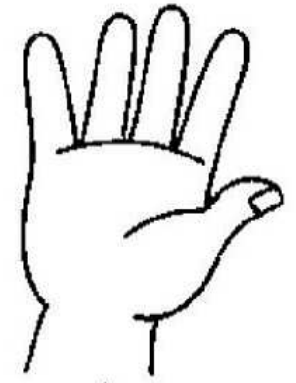

Colorea y escribe el número 5.

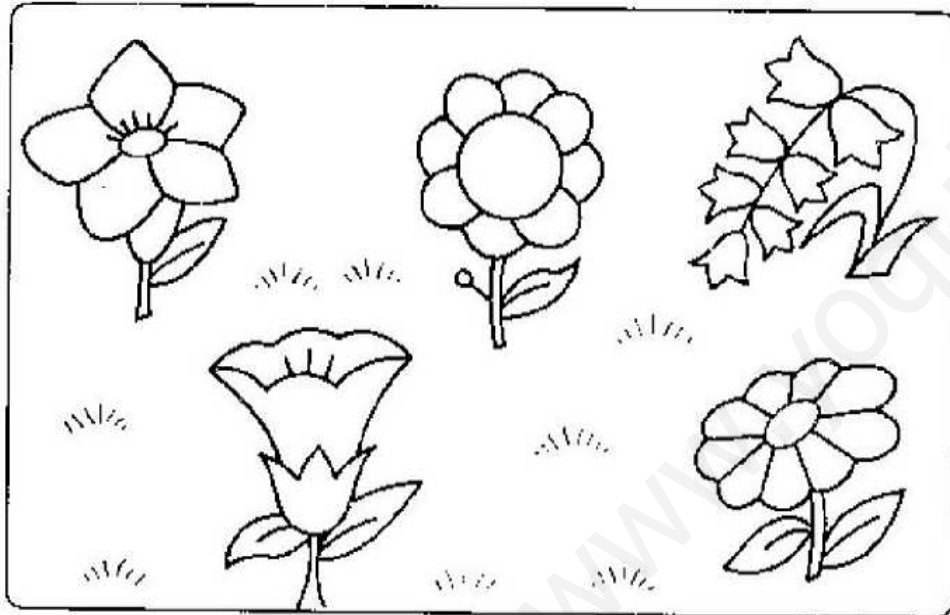
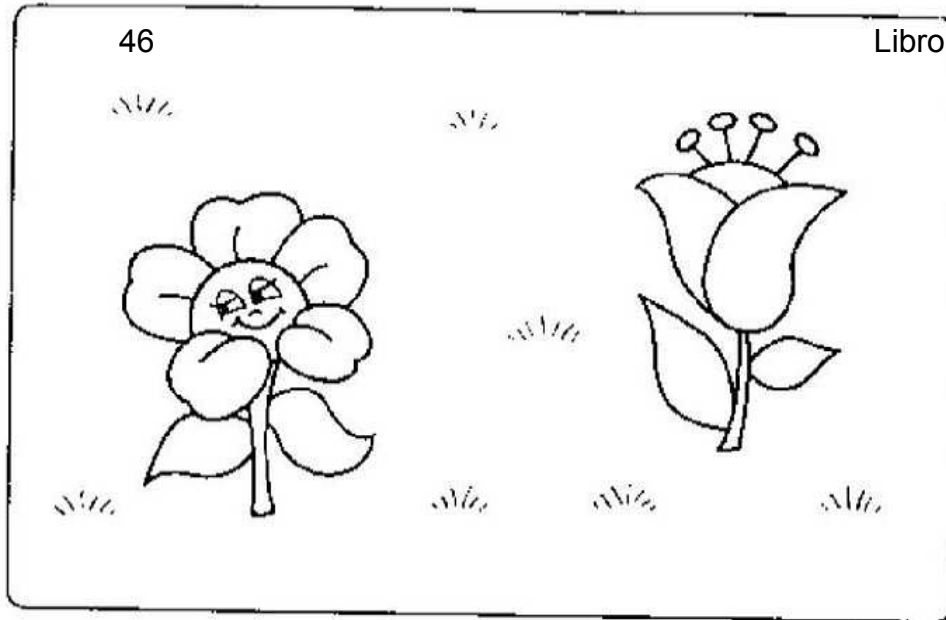

Colorea de amarillo las flores del recuadro donde hay pocas.

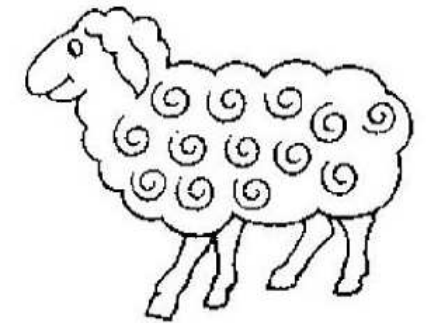
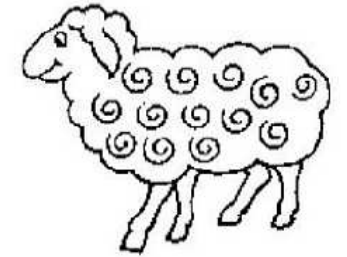
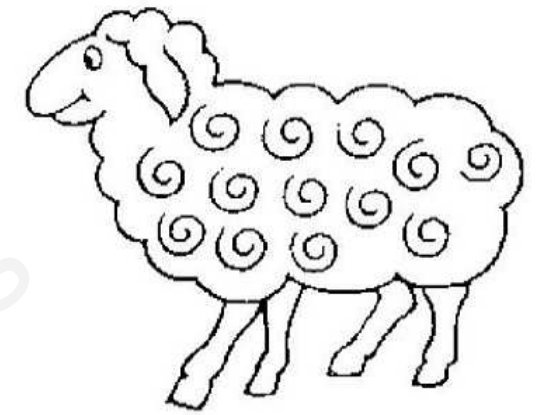

Une con una línea cada pastor con la oveja que le corresponda, según el tamaño, y pintaos.

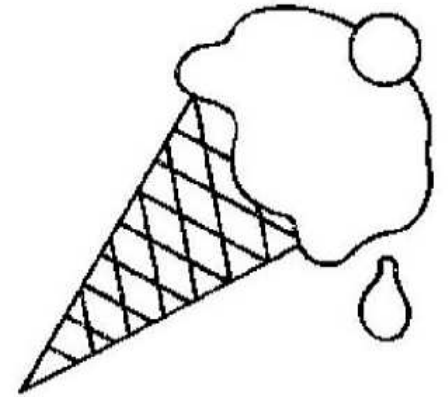
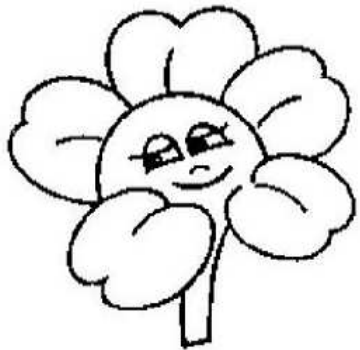
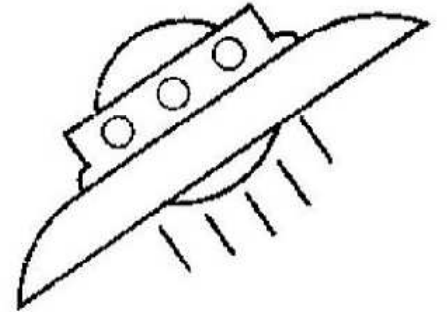
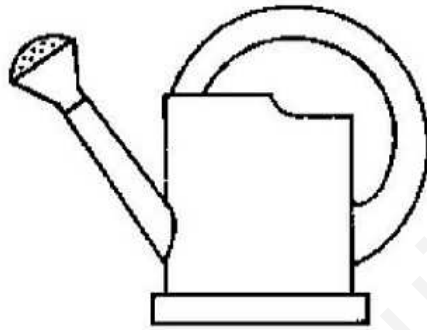
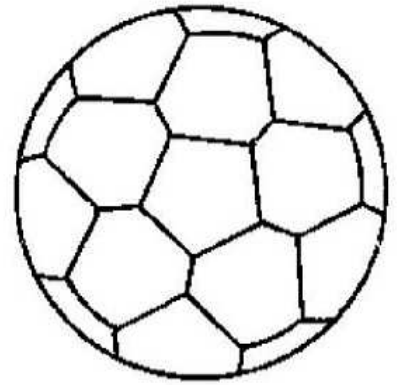
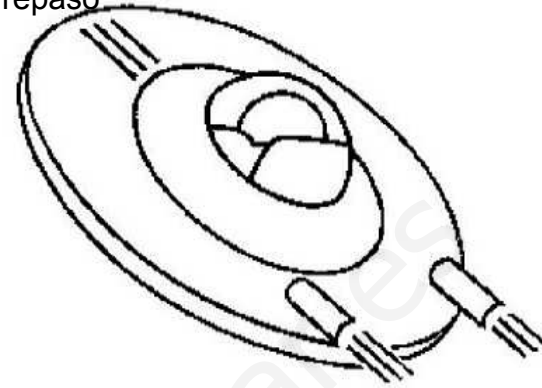

Une con una línea los dibujos que se correspondan y píntalos

Une los dibujos semejantes y da color.

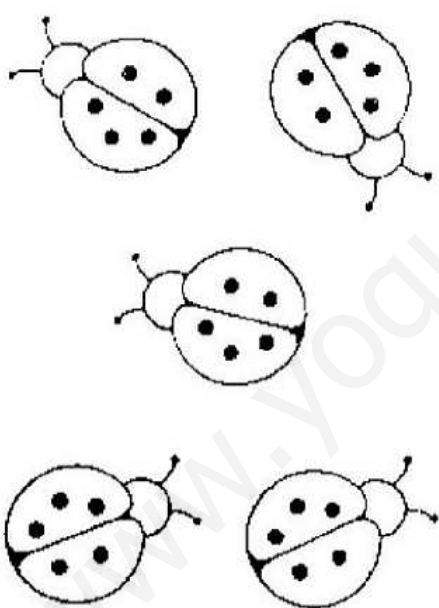
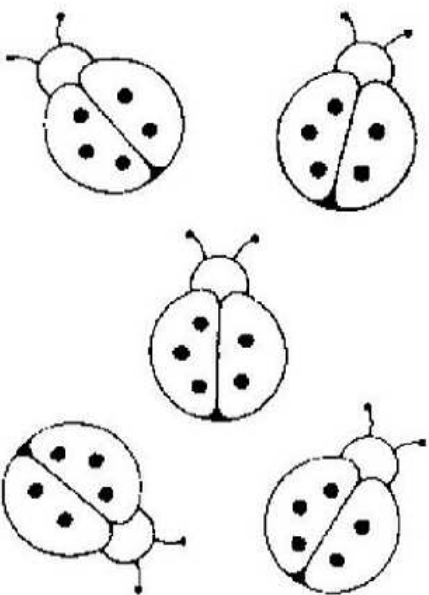
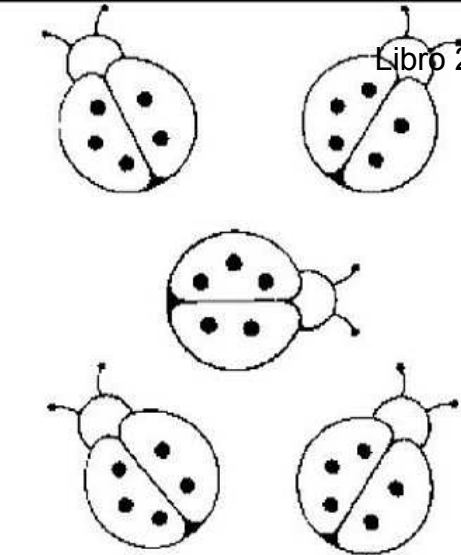
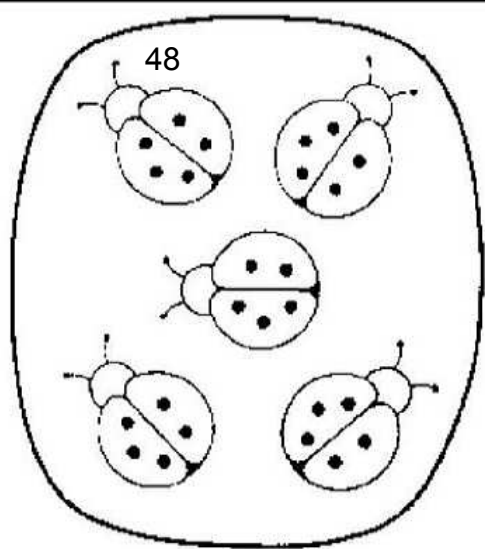

Pon las mariquitas en grupos de 5 como la muestra y píntalas.

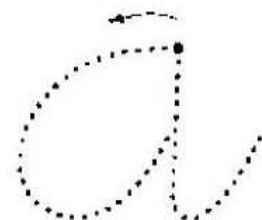
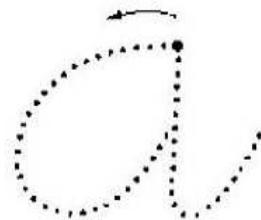
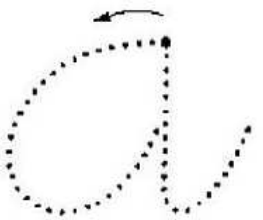
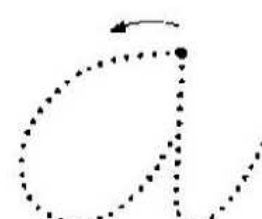
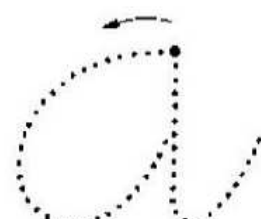
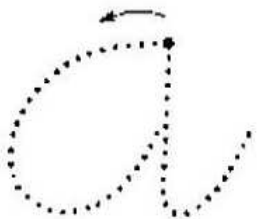
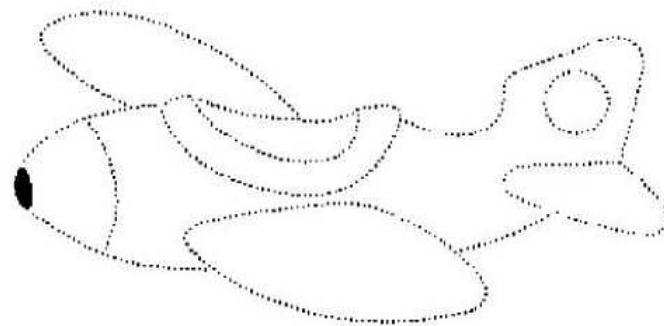
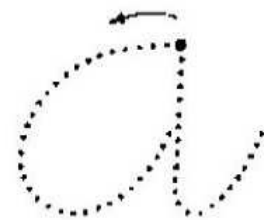
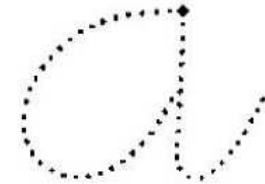
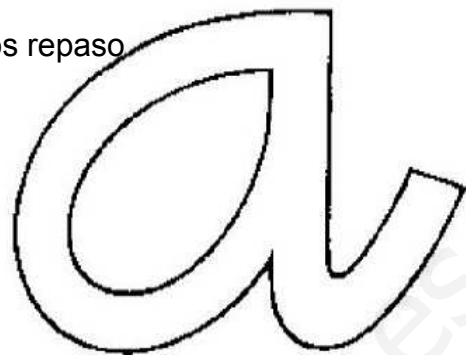

Escribe la letra a y colorea.

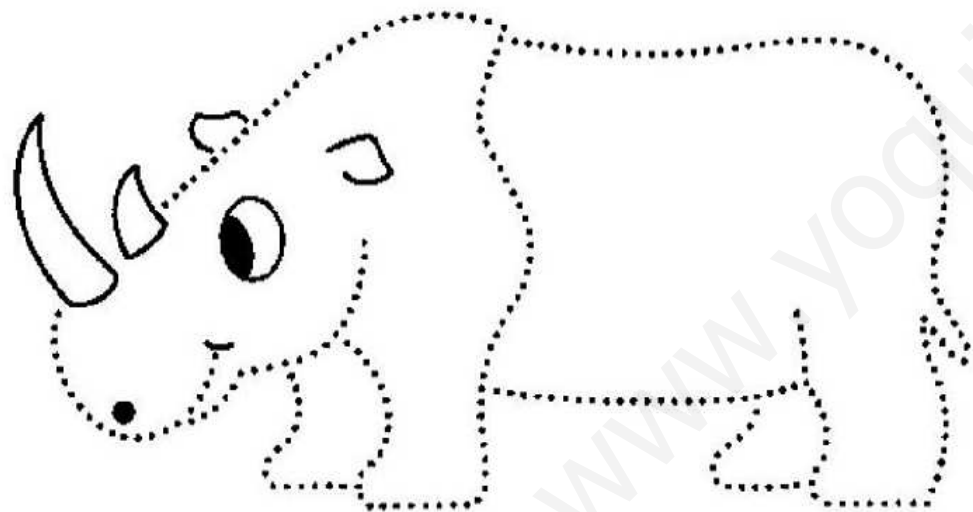
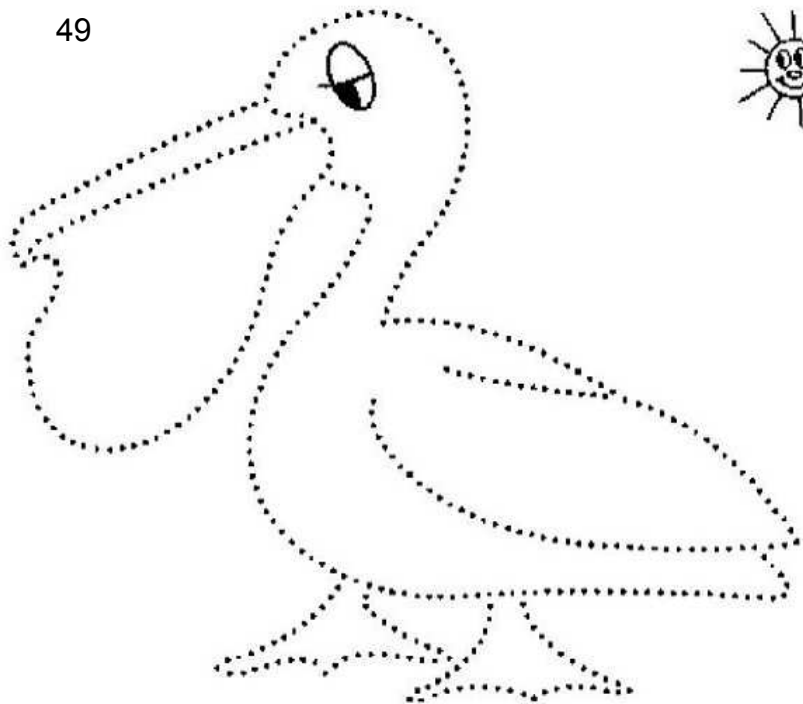
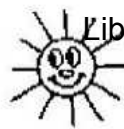

Sigue los puntos y colorea: en rosa el de arriba y en marrón el de abajo.



Pinta la casa que está detrás del árbol.

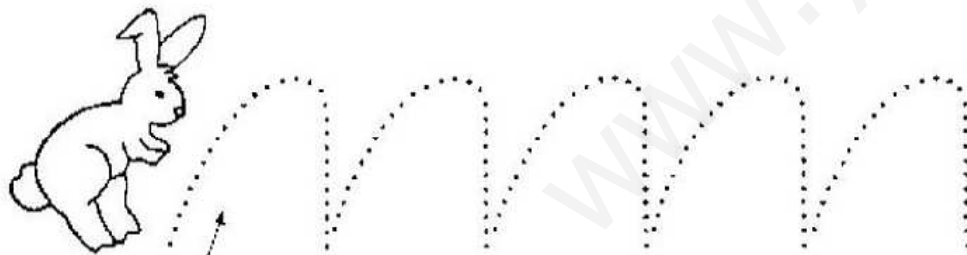
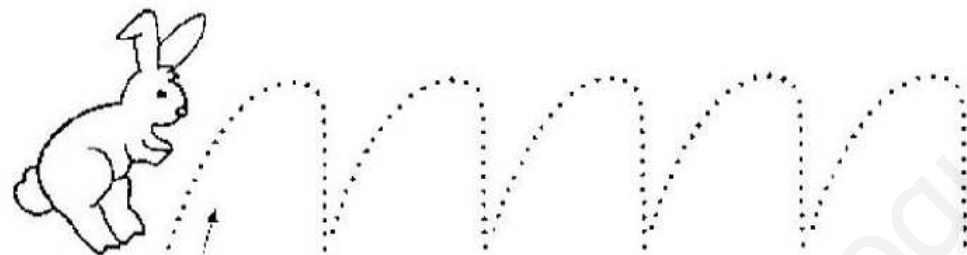
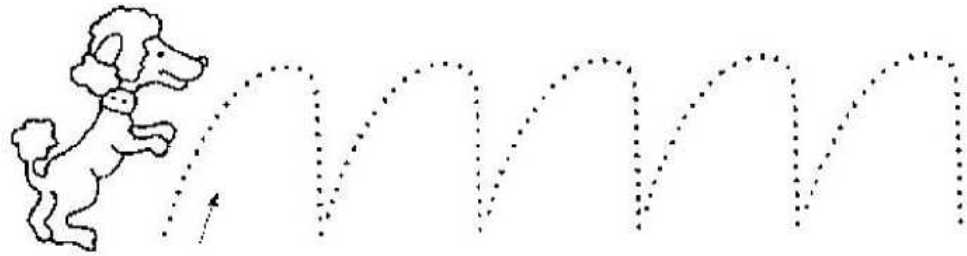
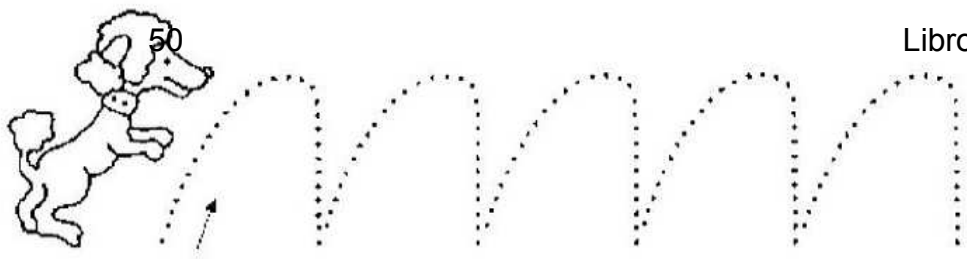

Repasa las líneas de puntos y colorea los animalitos.

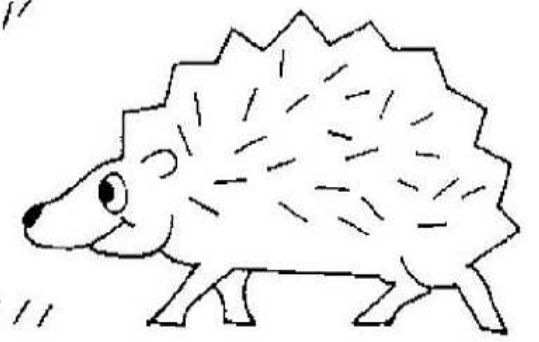
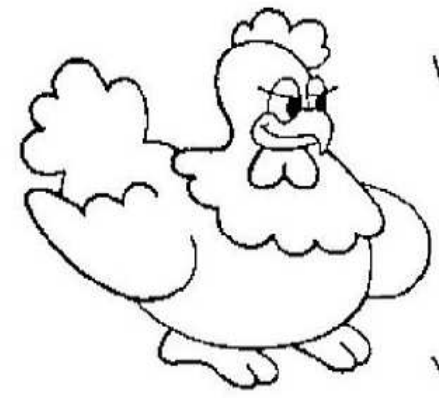
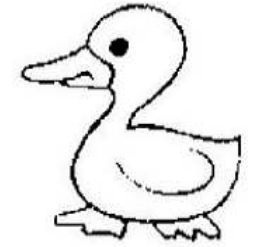
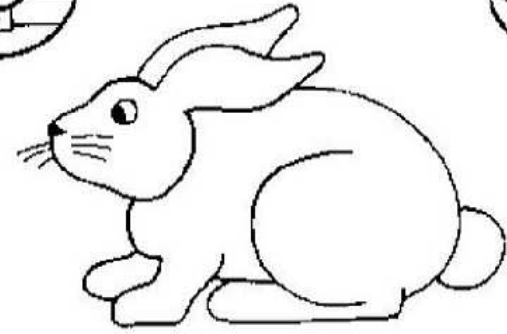
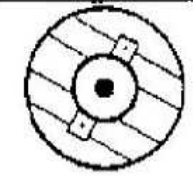
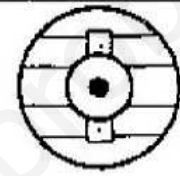
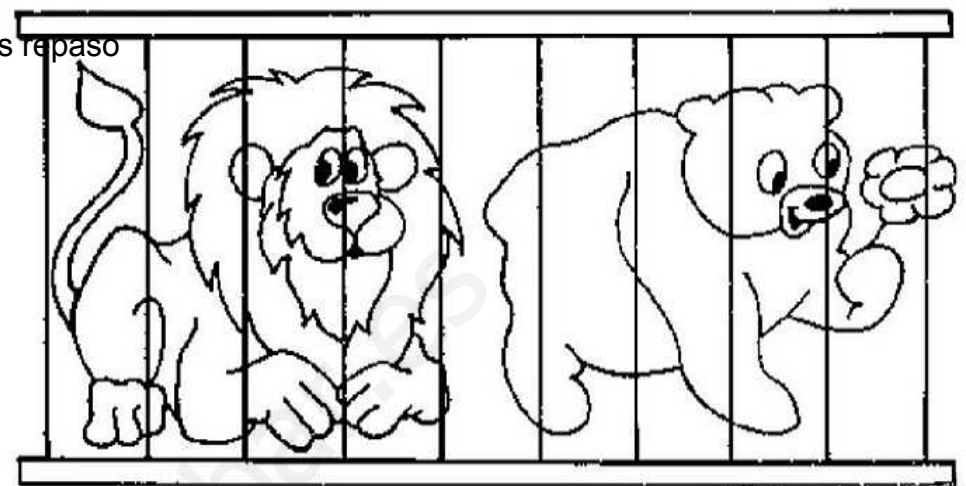

Pinta los animales que están fuera de la jaula.

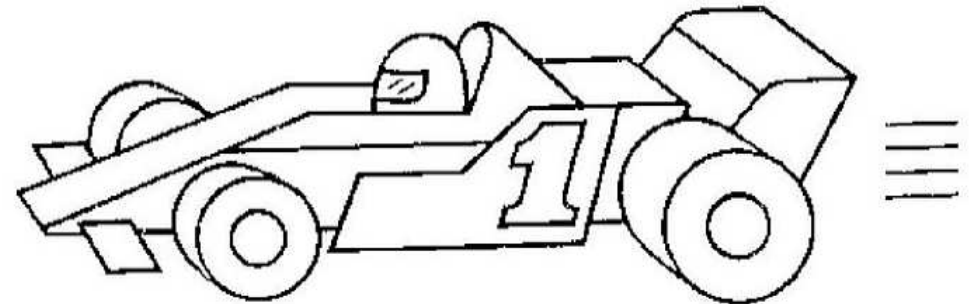
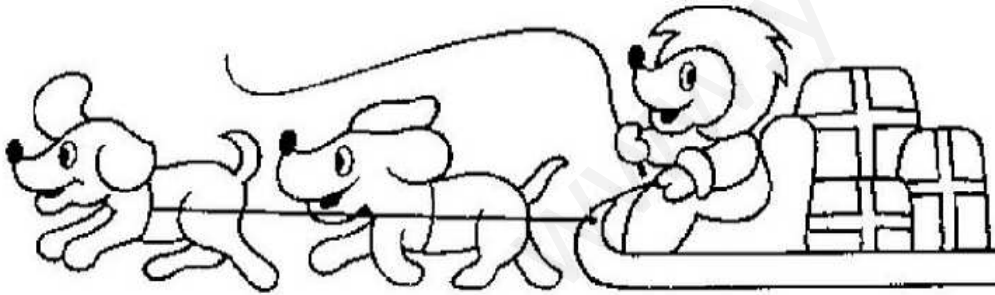
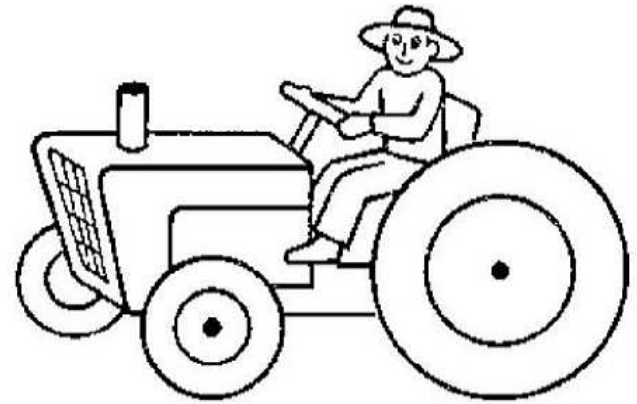
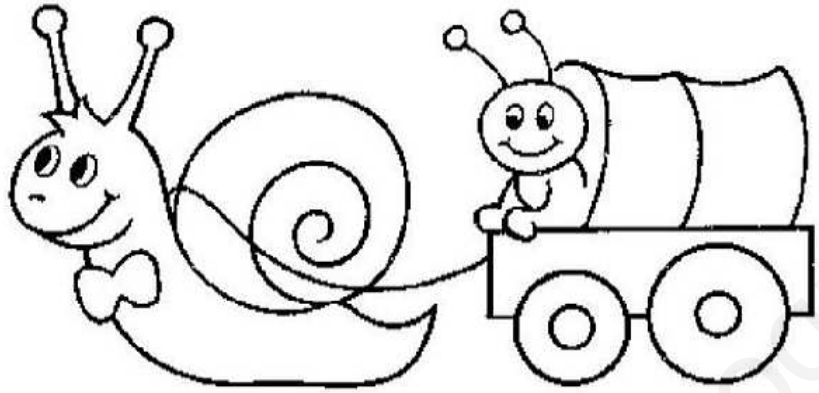
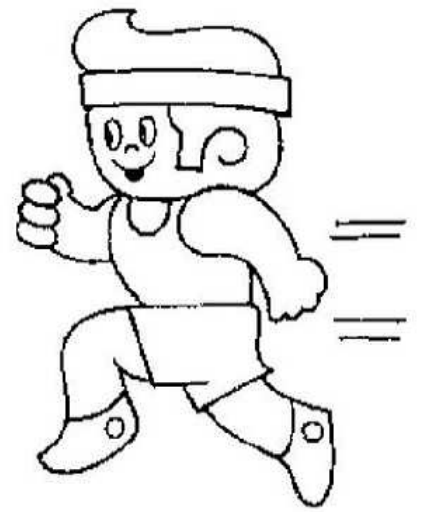
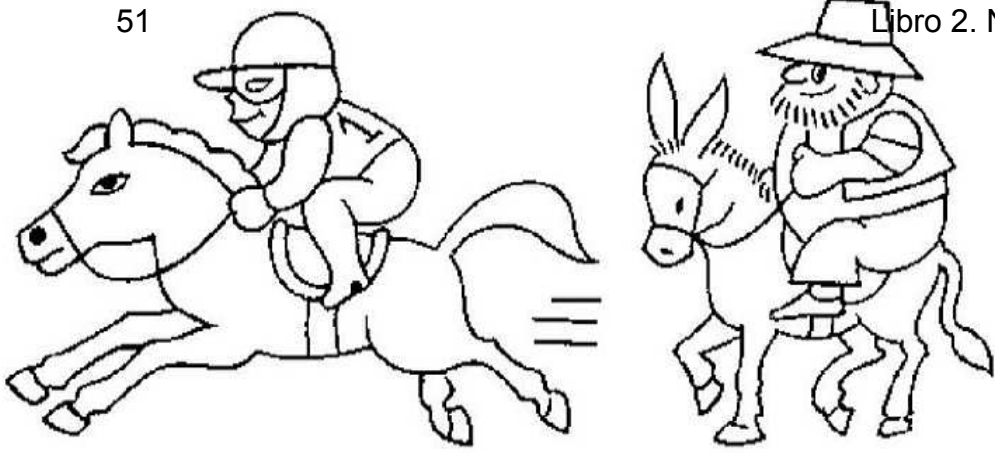

Colorea el que va más rápido en cada recuadro.

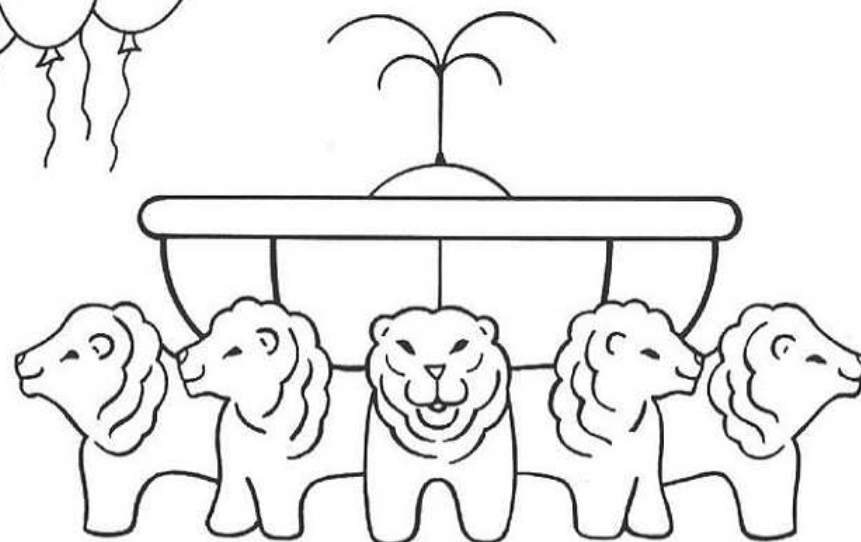
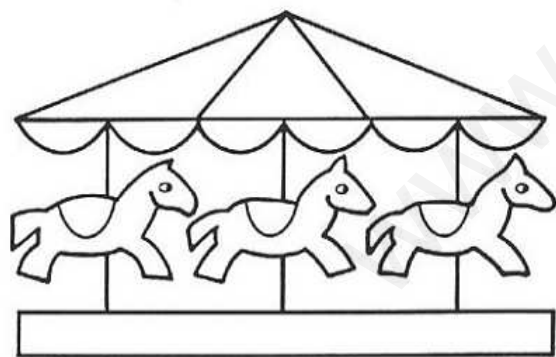
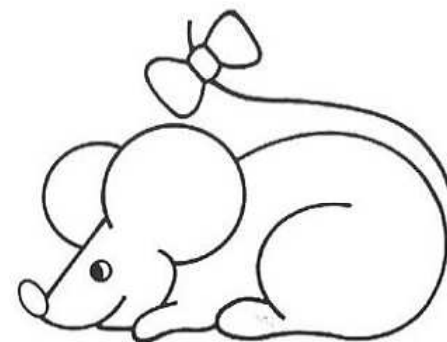
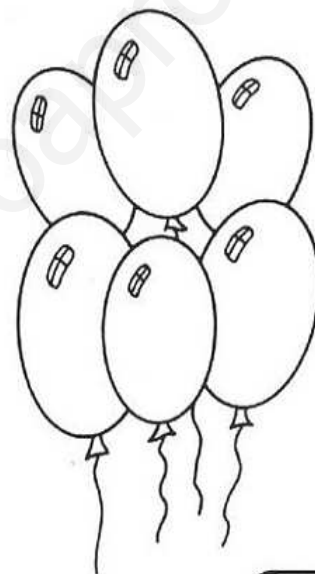
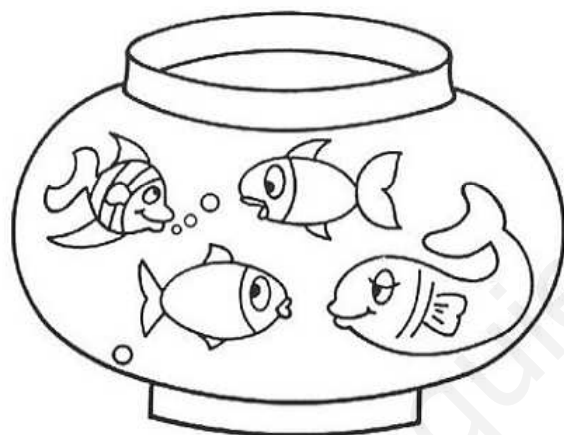
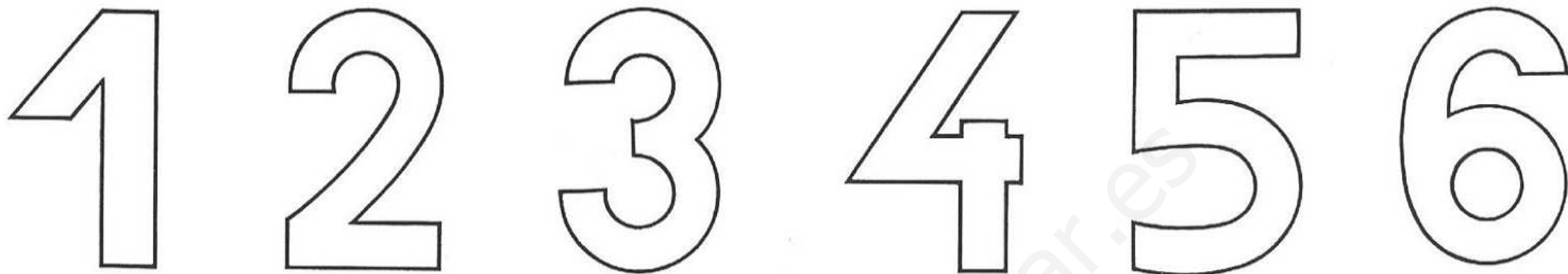

Une con una línea cada dibujo con su número y da color.

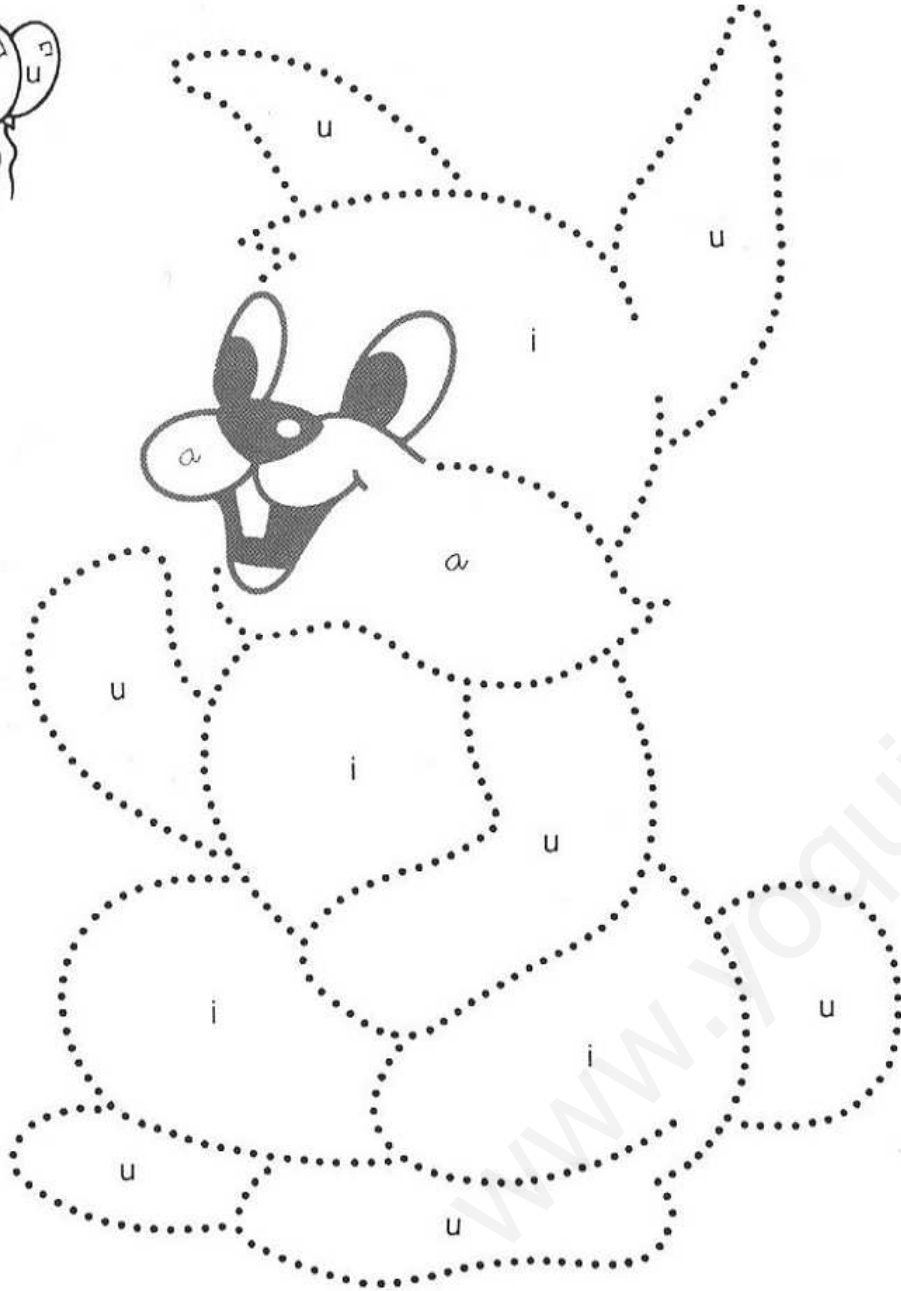
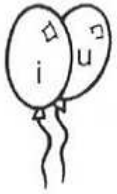

Sigue los puntos del conejo y colorea : *a* en gris, *i* en rosa y *u* en morado.



Sigue los puntos y colorea de marrón el que está encima del árbol y de naranja el que está debajo.

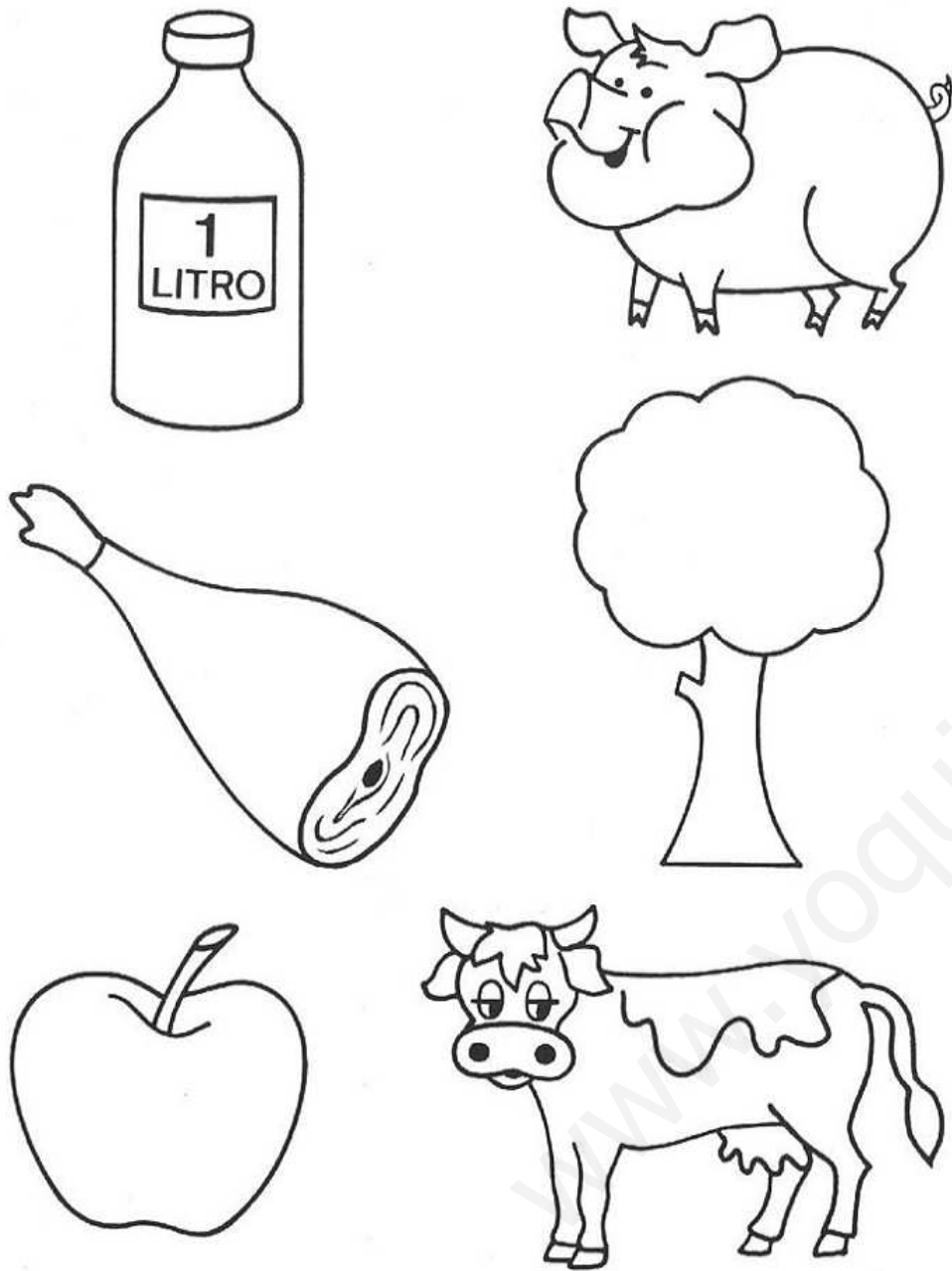

Une con una línea los dibujos relacionados entre sí y píntalos.

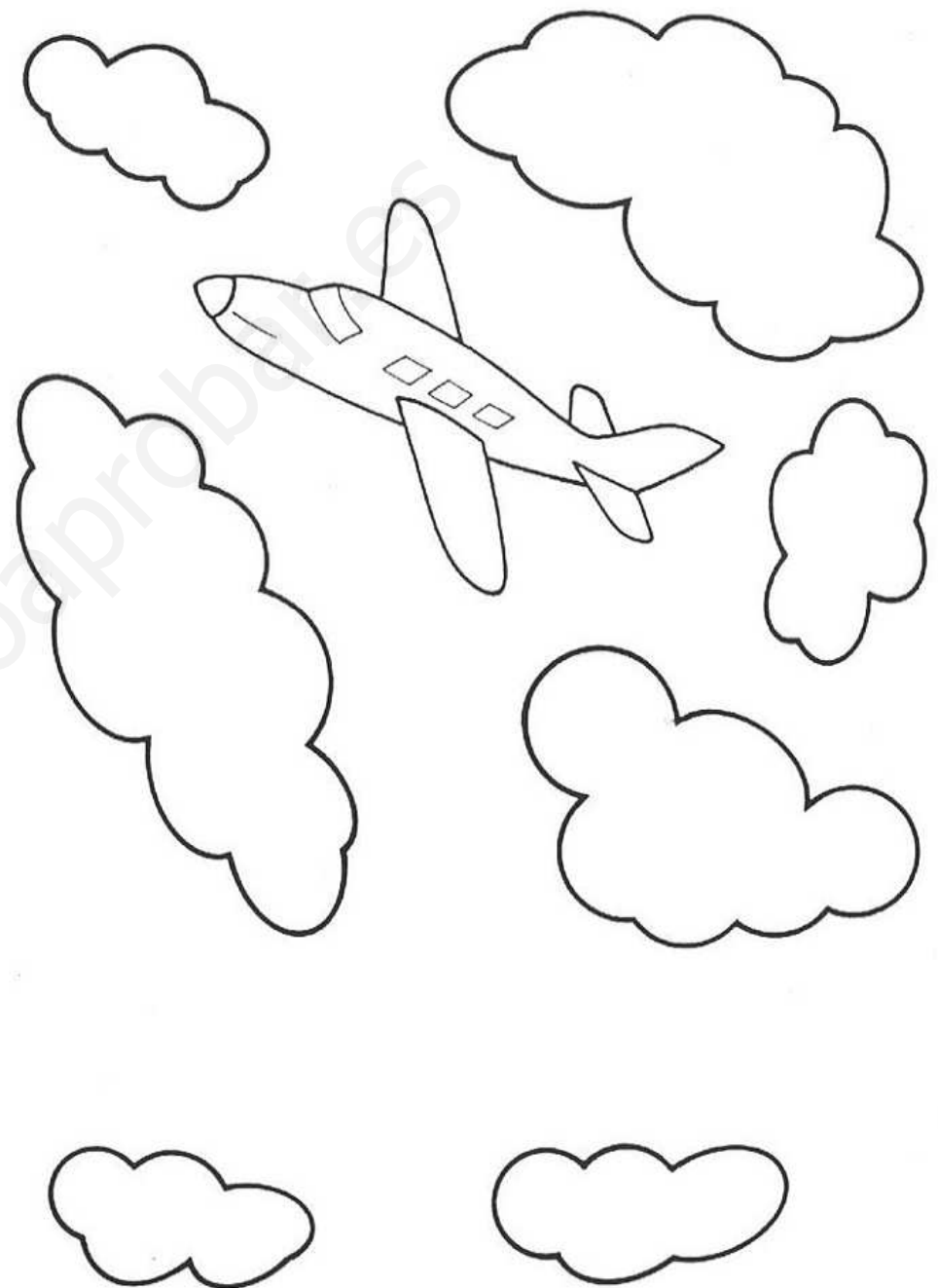

Pinta las nubes que están alrededor del avión.



Colorea la ardilla y el niño que van delante.

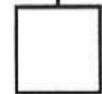
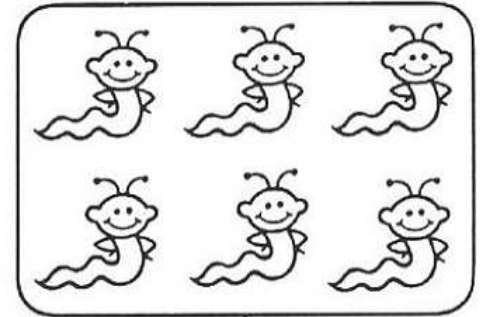
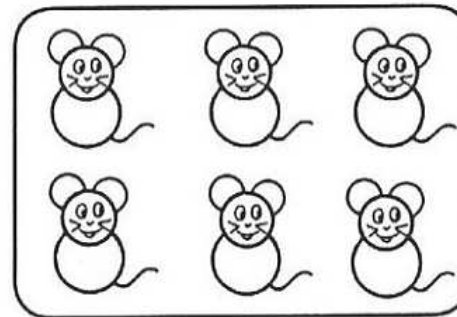
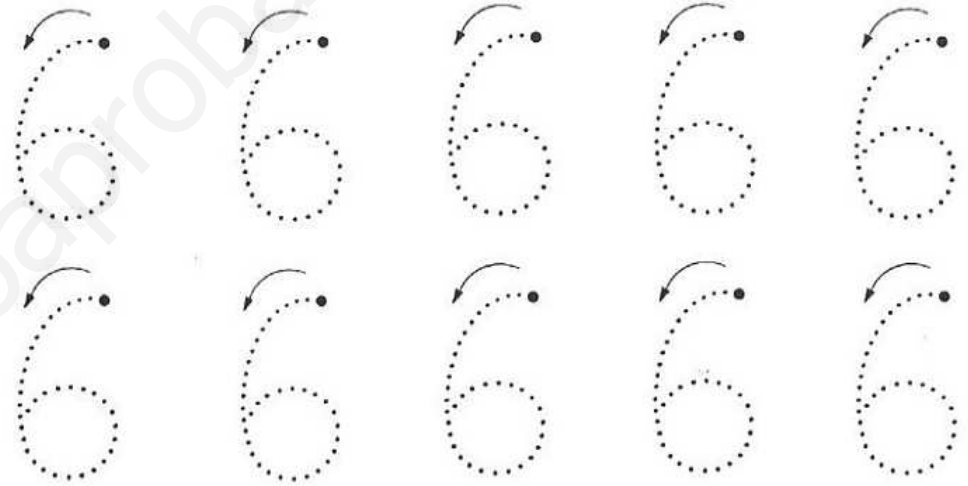
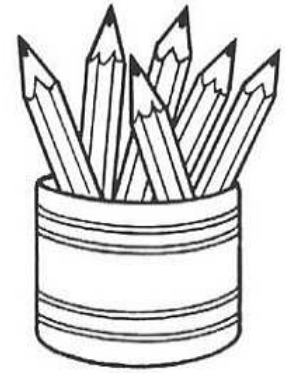

Colorea y escribe el número 6.

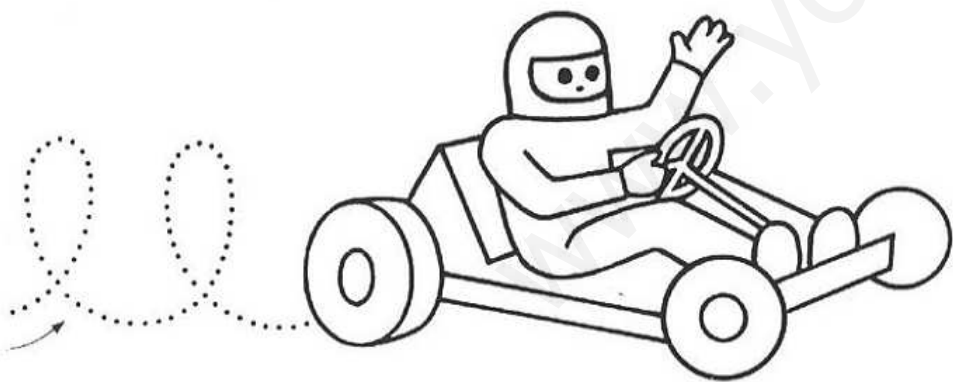
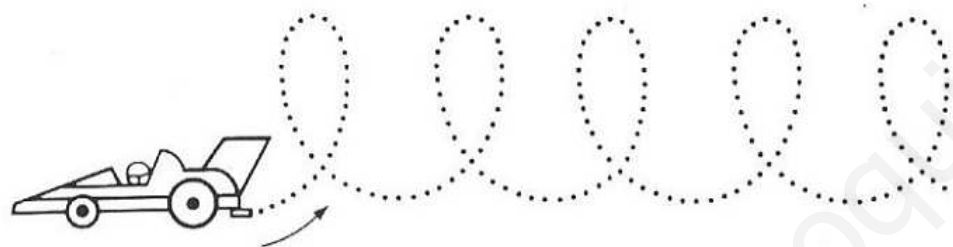
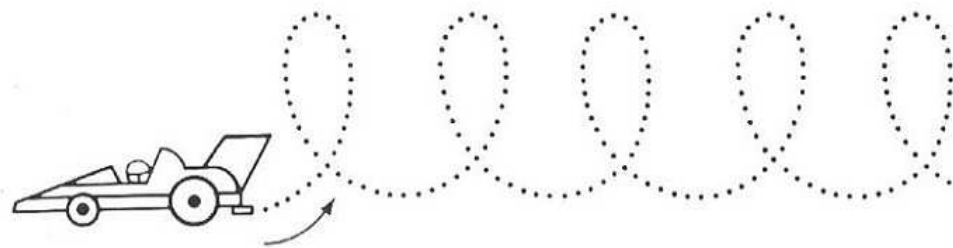
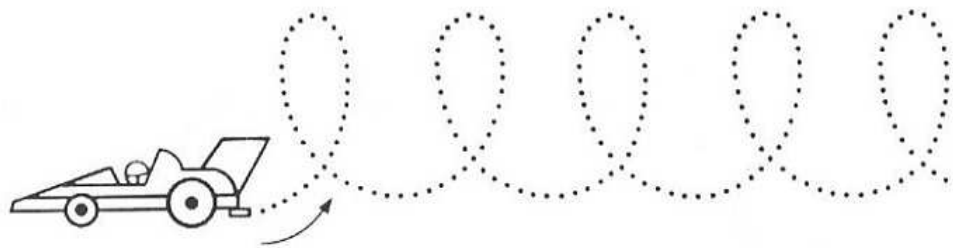

Repasa las líneas de puntos y colorea los coches.

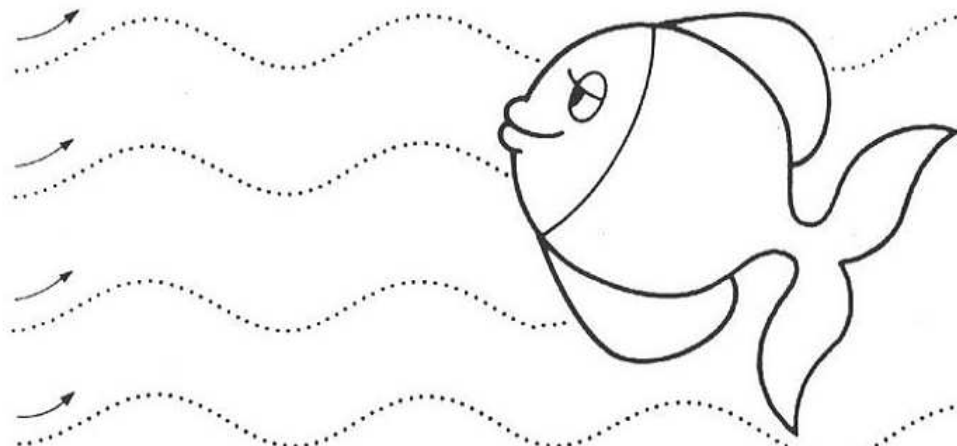
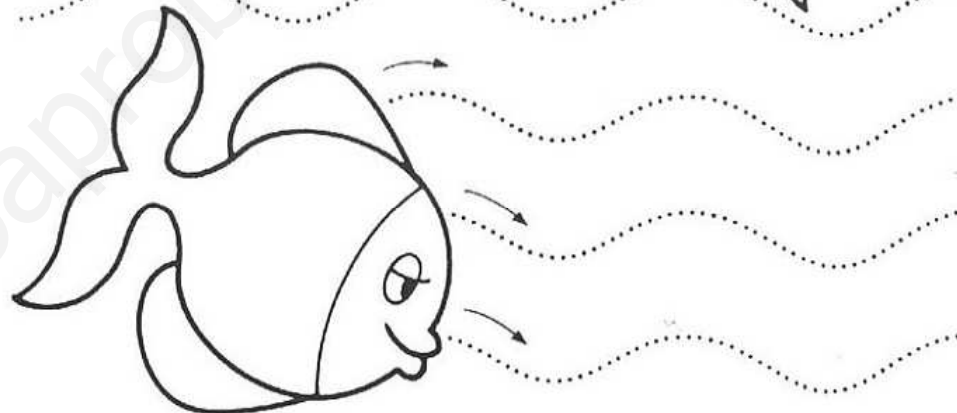
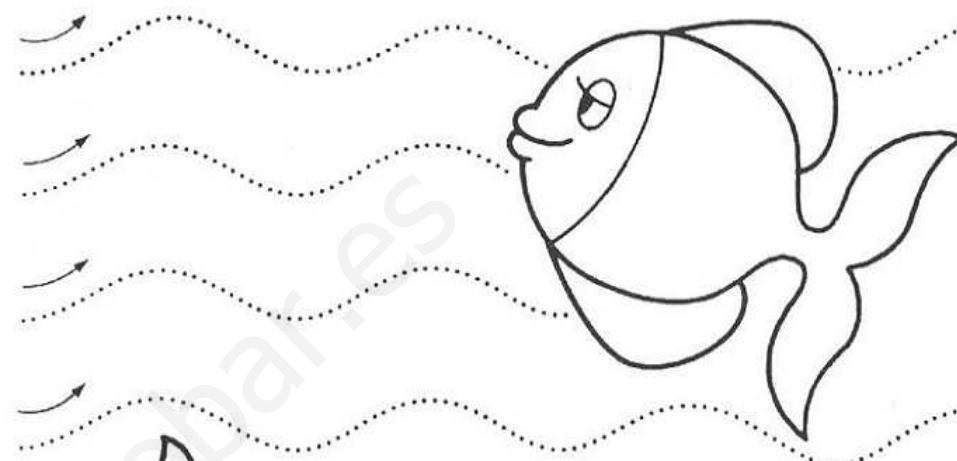

Repasa las líneas de puntos y colorea de rojo los peces que van hacia arriba.

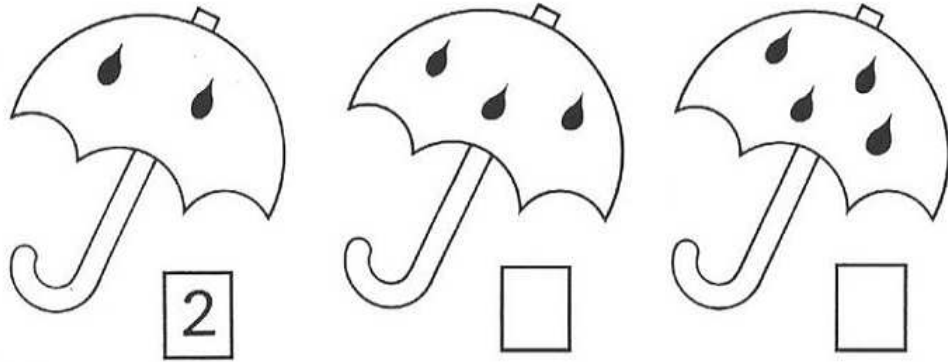

Cuenta las gotas y escribe el número como en el primero.

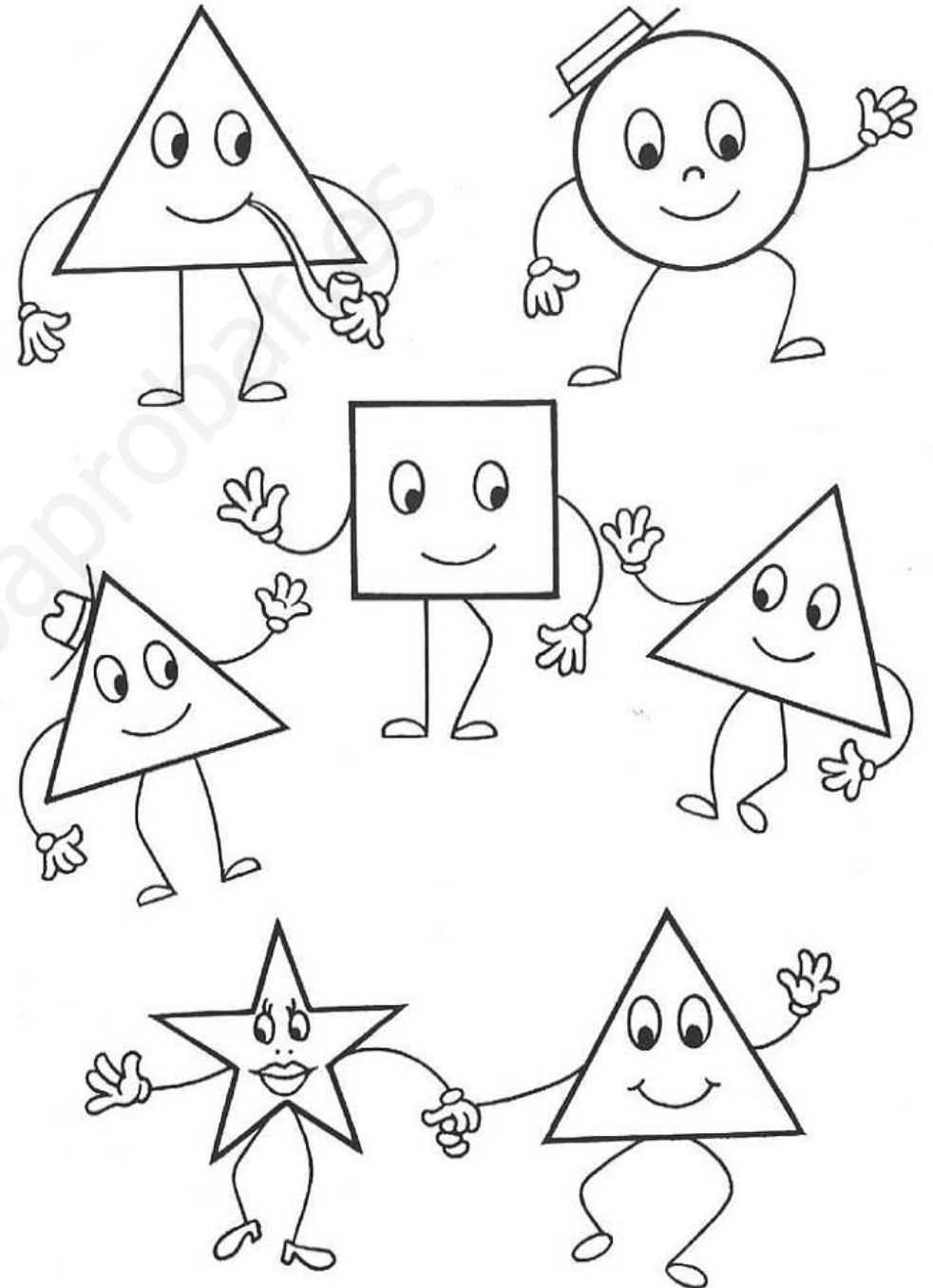

Colorea las figuras que tengan forma de triángulo.

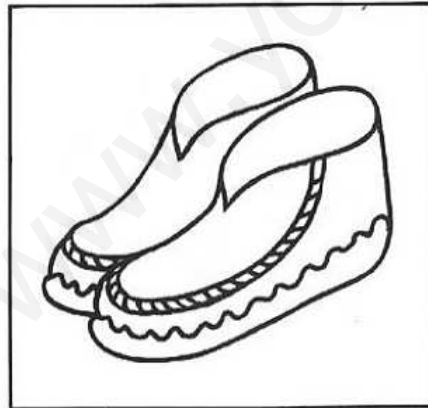
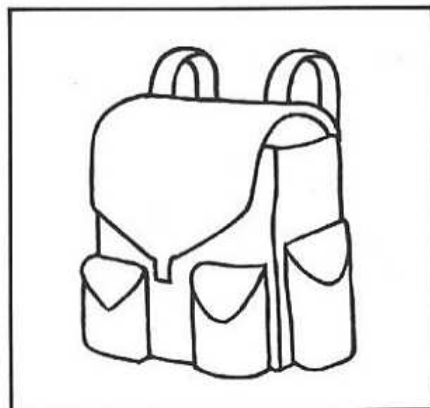
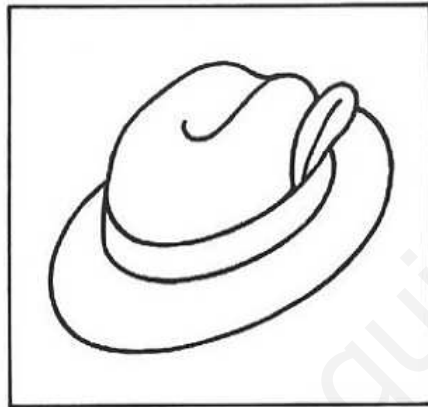
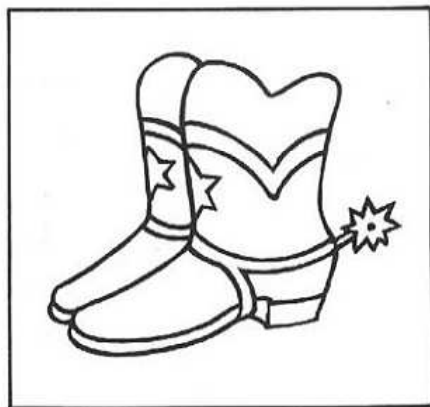
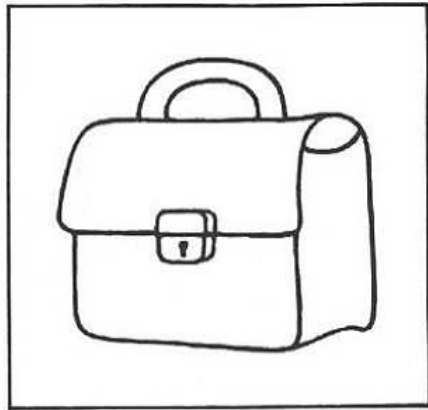
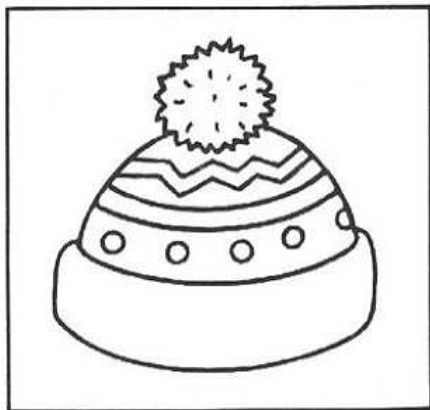

Une con una línea los que sean semejantes y píntalos.

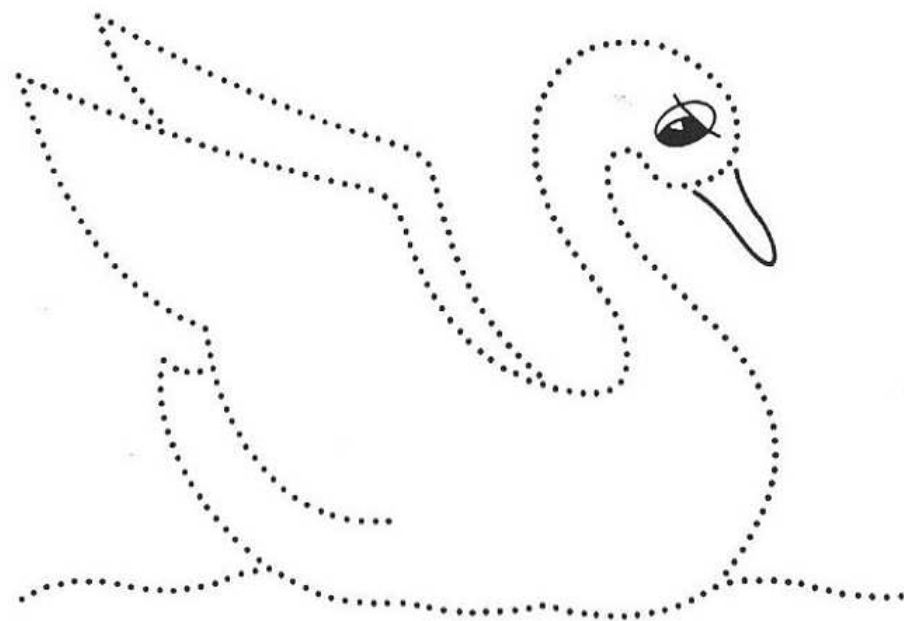
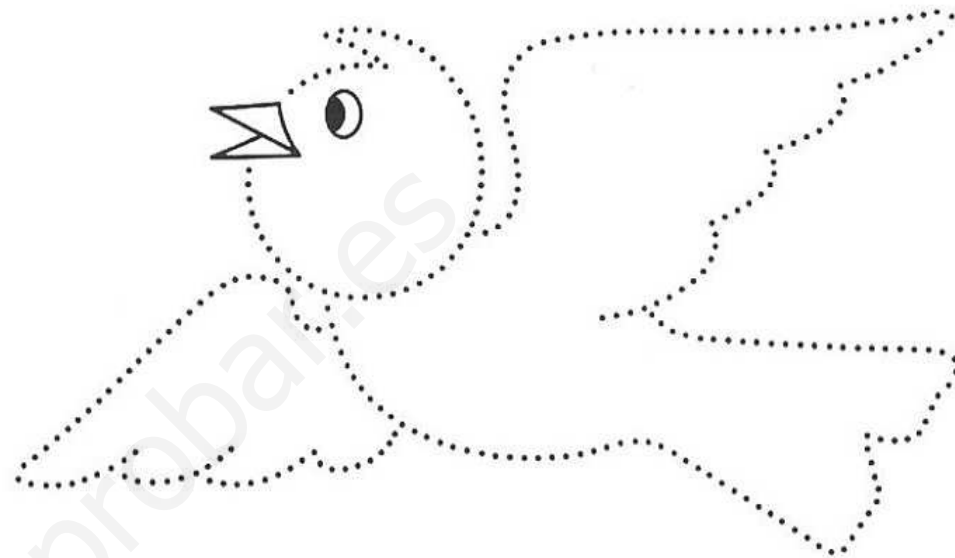

Sigue los puntos y colorea: en rosa el que está volando y en azul el que está nadando.

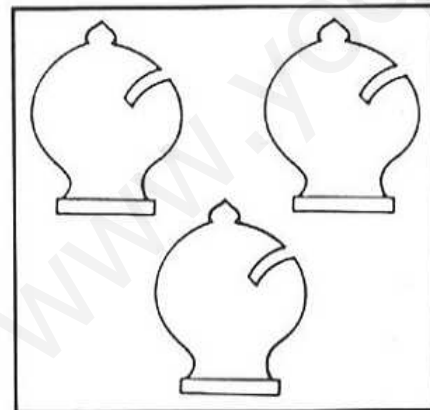
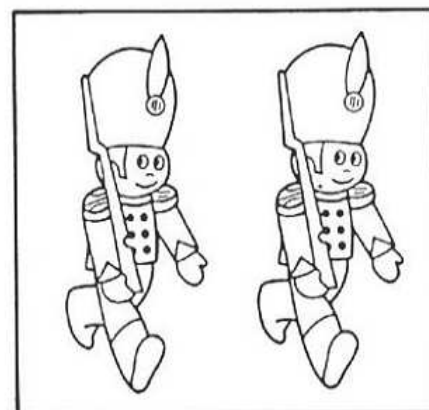
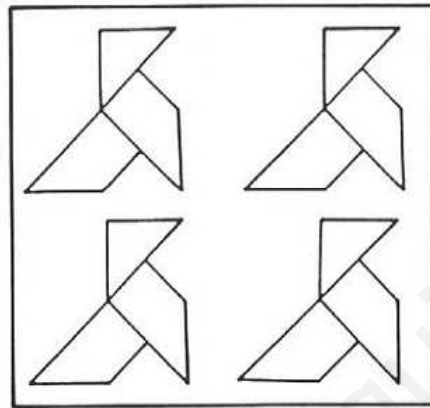
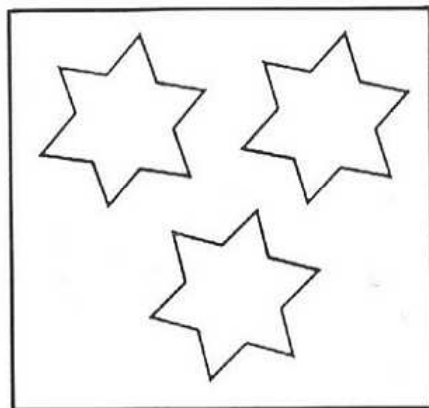
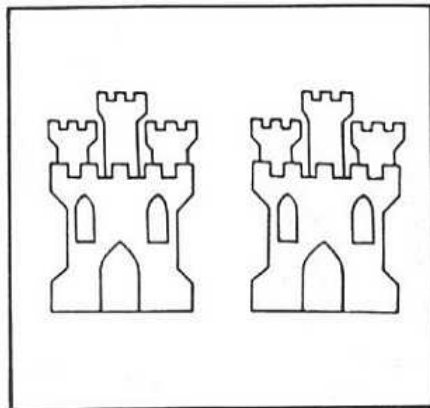
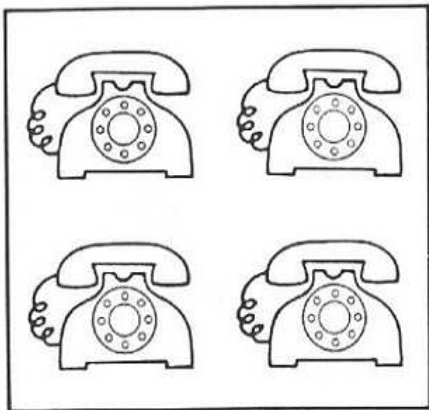

Une los cuadros que tienen el mismo número de cosas y colorea.

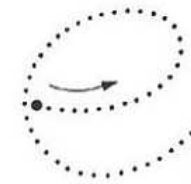
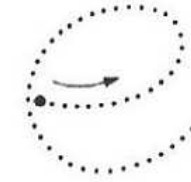
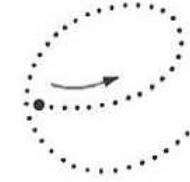
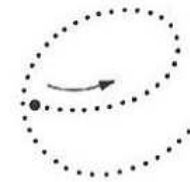
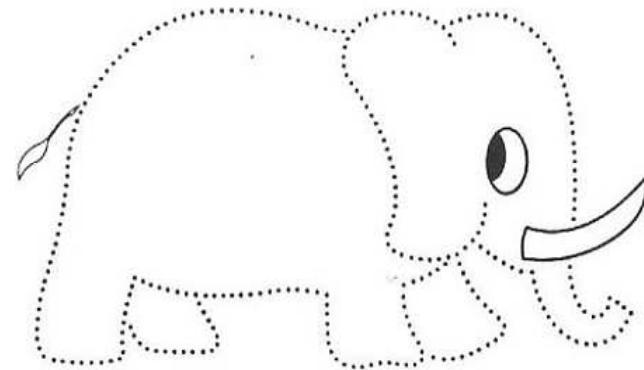
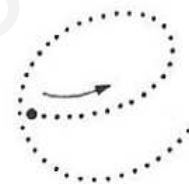
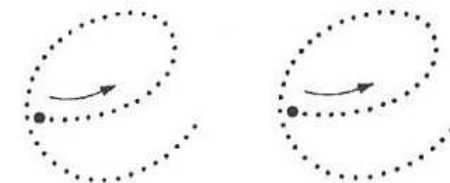
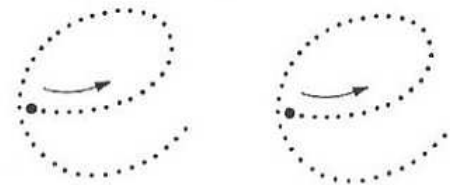

Escribe la letra e y colorea.

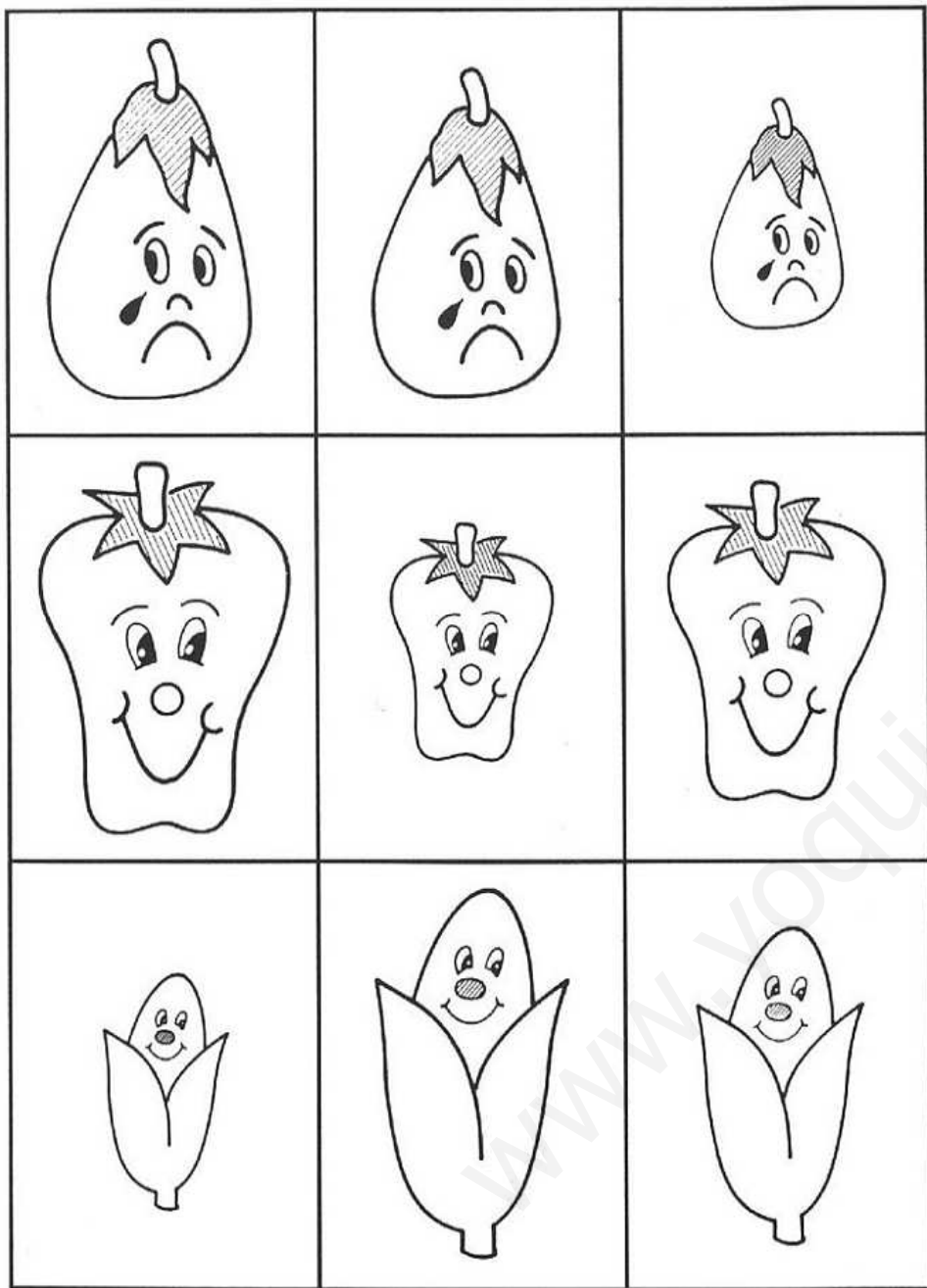

Colorea todos los dibujos y rodea con un círculo los más pequeños.



Colorea de rojo las cosas de aseo y de azul las de vestir.

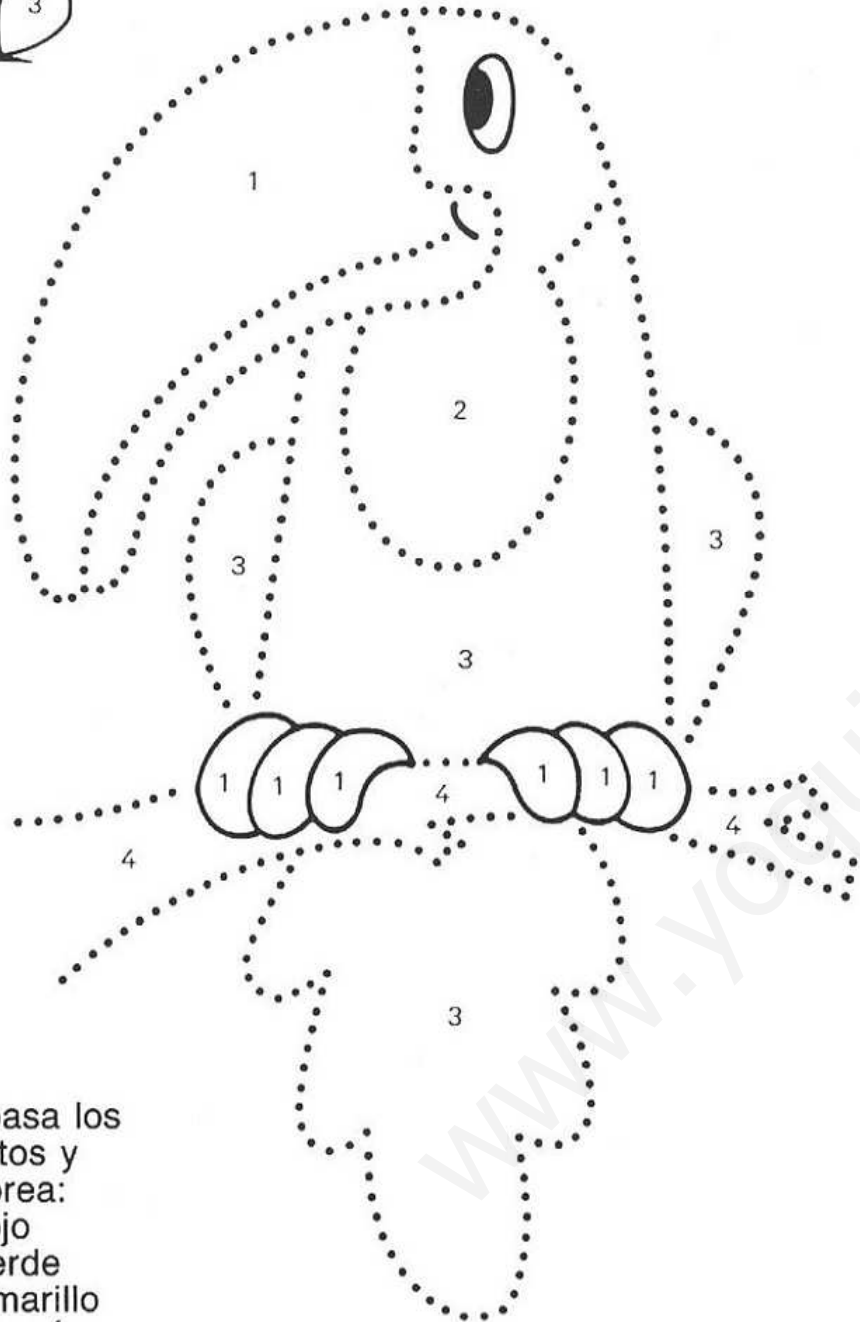
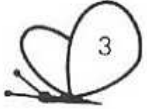

Repasa los
puntos y
colorea:
1 rojo
2 verde
3 amarillo
4 marrón.

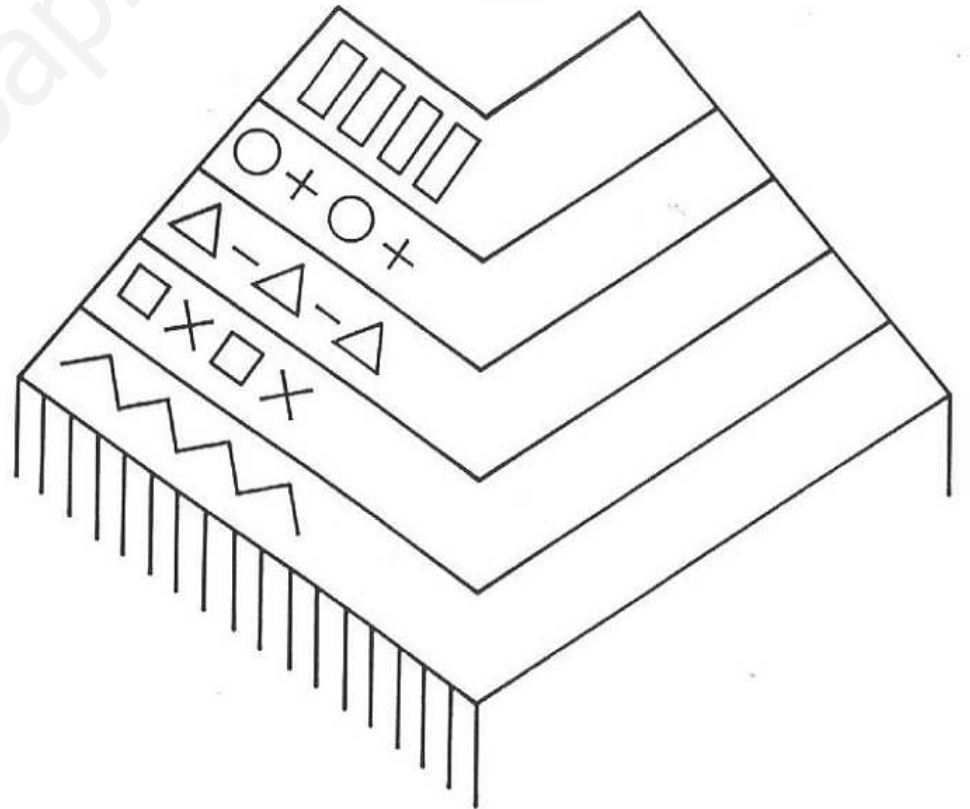
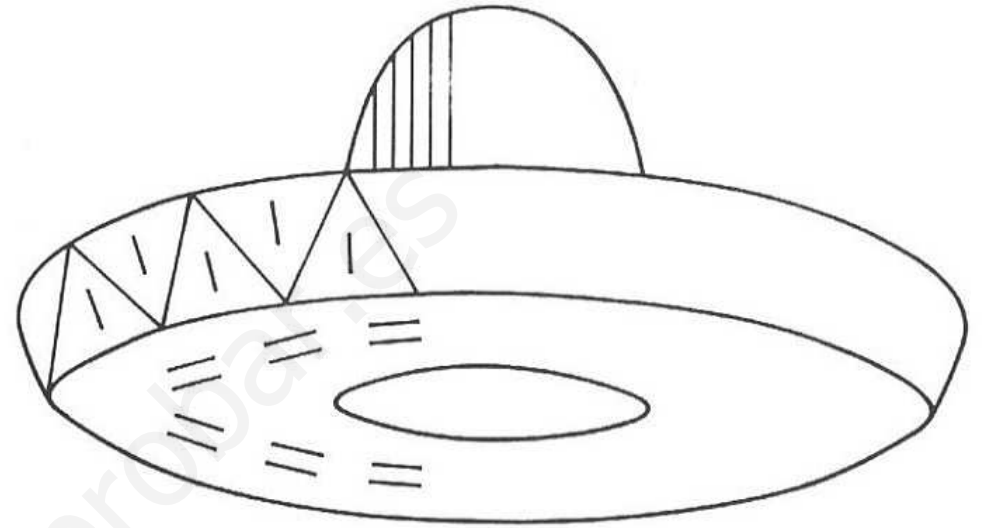

Continúa las cenefas y colorea.