

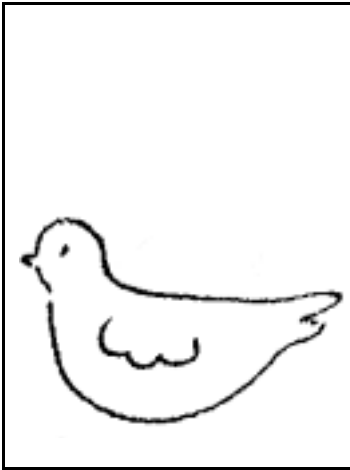

pa pe pi po pu
ap ep ip op up

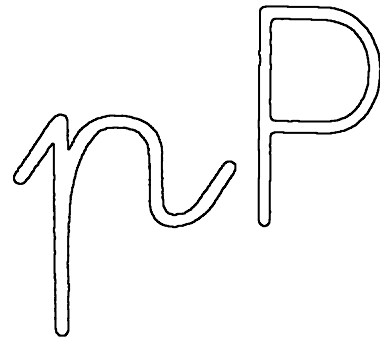

paloma

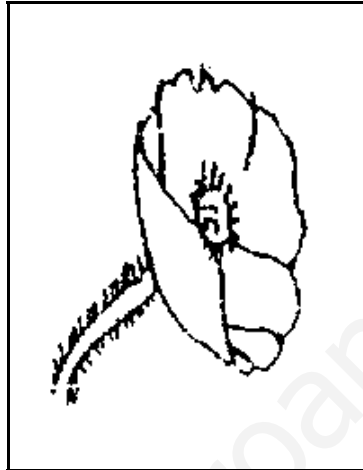

amapola

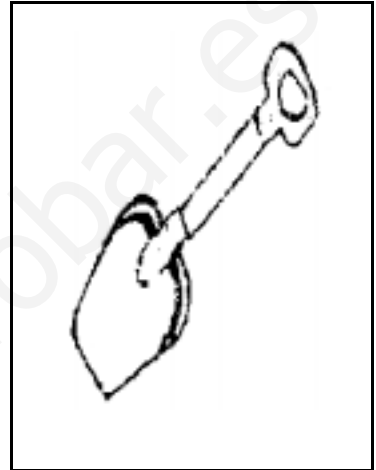

pala



sopa



sapo



papá

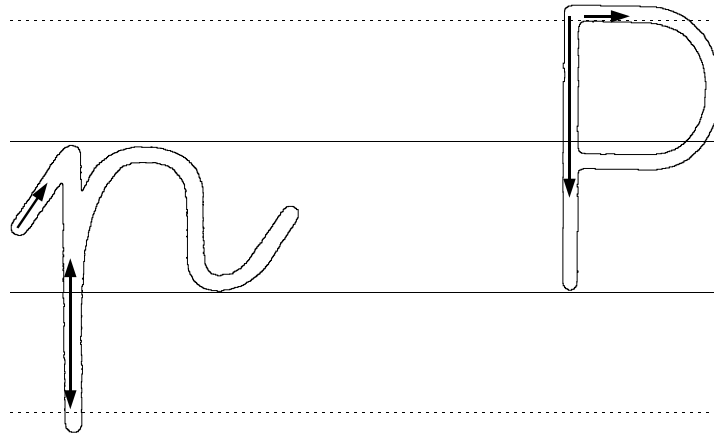

na ne ni no nu

an en in on un

Pa Pe Pi Pe Pa

papá pipa pis Pepe

sapo pila sopa pelo

pala pases pipas peso

Pepe pasea a Lulú.

Pili pisa la amapola.

Papá olía el pemelo.

Papá alisa el pelo a

Pili.



Pa Pe Pi Pe Pu

na ne ni ne nu

M. mamá pasa casa

El ese pasa al sol

Pila se alisa el pelo

Mamá asa el pulpo

Paula lee noticias

Luis me pisa el pie



Pepe pasa la pala



El pelo de Pili

Pepe pasea a Lulú



pelo

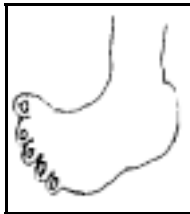

ripa
paloma



mapa



pala

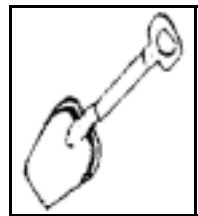

pila

pie

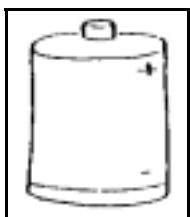

muela

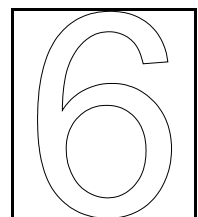

seis



amapola



pala



sopa



sapo



paleta

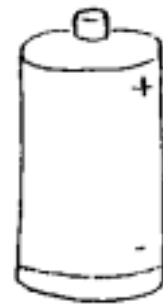

pila



pipa



pie



papá

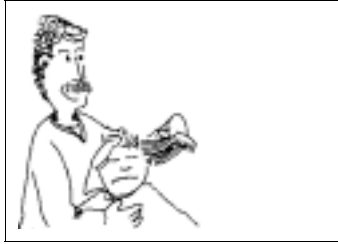

Papá alisa el pelo a Pili



Paloma olía las amapolas



Pepe pasa la pala a Elisa



Luis me pisa el pie



los las

los _ polos

_____ sapos

_____ palos

_____ pesos

_____ lomos

las _ pilas

_____ pipas

_____ pesas

_____ palas

_____ mapas

~~suma~~ ~~miel~~ ~~pomelo~~ ~~lila~~ mesa
 pelo sapo lima muela lomo
 Lola sol mula papá seis pala

l

lila

m

miel

s

suma

p

pomelo



Leo...



Pepe y papá

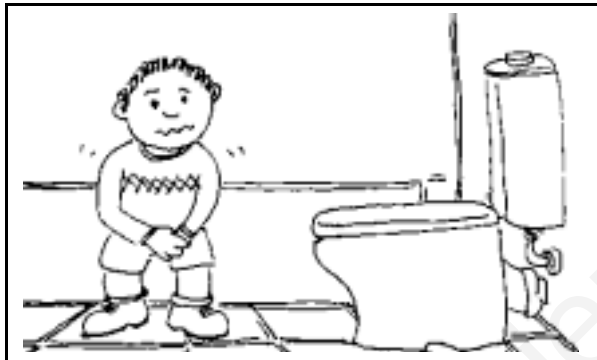

Papá, papá, pipí

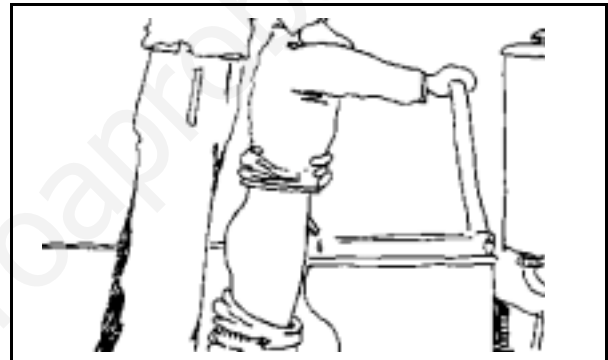

Sí, sí, Pepe











Papá, papá,
pupa



Papá mima a
Pepe





~~Papá,~~ Pili



Papá alisa el pelo a

Paloma, las

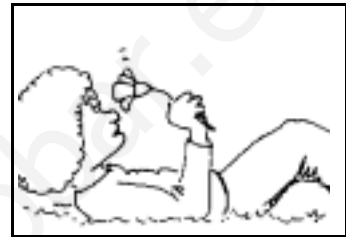

olía amapolas



Pepe, Elisa

pasa la pala a

pisa, pie



Luis me el



Mi papá pasea solo.
El oso pasea al sol.
Pili se alisa el pelo.
El sapo pisa la amapola.
Pepe olía la sopa.
Seis palomas, seis palomos.
Mamá asa el pulpo.
Paula lee poesías a Pepe.



Handwriting practice lines consisting of multiple sets of three horizontal lines (top, middle, bottom) with a dotted line in the middle. Two small circles are placed at the beginning of the first two lines.



Tema 5	第五课	Unit 5
Pepe y Papá.	贝贝和爸爸	Pepe and Dad
Papá, papá, pipí.	爸爸，爸爸，撒尿。	Daddy, daddy, I need a wee
Sí, sí, Pepe.	好，好，贝贝。	Yes, yes, Pepe
Papá, papá, pupa.	爸爸，爸爸，结疤了。	Daddy, daddy, it hurts
Papá mima a Pepe.	爸爸宠爱贝贝。	Dad cuddles Pepe



Mi papá pasea solo.	我爸爸一个人散步。	My dad walks alone
El oso pasea al sol.	熊在太阳下散步。	The bear walks in the sun
Pili se alisa el pelo.	碧丽把头发梳直了。	Pili smooths her hair down
El sapo pisa la amapola.	癞蛤蟆踩了虞美人花。	The toad steps on the poppy
Pepe olía la sopa.	贝贝闻到了汤的香味儿。	Pepe smelled the soup
Seis palomas, seis palomos.	六个雌鸽，七个雄鸽。	Six female doves, six male doves
Mamá asa el pulpo.	妈妈烤章鱼。	Mum roasts the squid
Paula lee poesías a Pepe.	巴乌拉念诗给贝贝听。	Paula reads poetry to Pepe



ta te ti to tu
at et it ot ut

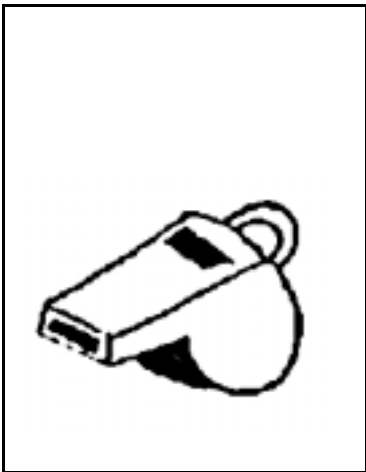
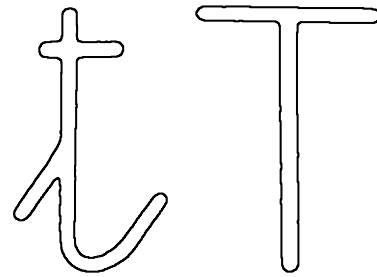

pito

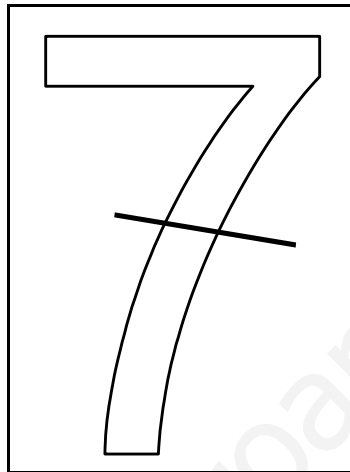

siete



seta



tapa

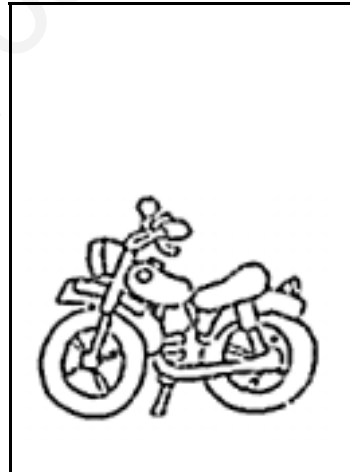

moto

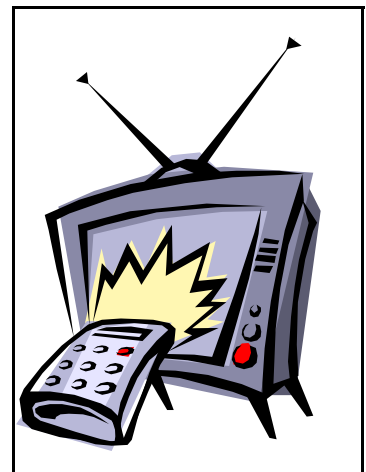

tele

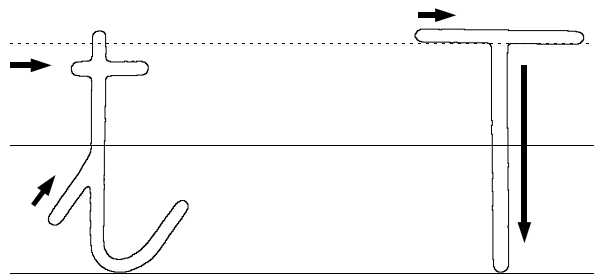

ta te ti te tu
at et it et ut
Ta Te Ti To Tu

tapa topo maleta
pito pata patito
tomate tela lata

Mamá pata, papá pata.
Papá pata pela patatas.
Mamá pata asa tomates.
Maite toma té.

Mamá pata pasea a sus seis
patitos.



T a T e T i T o T u

T a T e T i T o T u

Mamá papa, mamá papa

El ese papa al pate

El patite se asa

La papa toma la mela

Ella pela papatas

Aya toma la pelota



Lola se asea el pelo



Alí toma la lata

Emilio pasa a Lulú

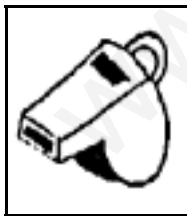
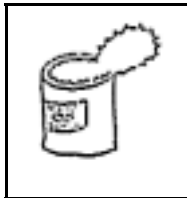
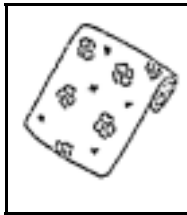

tela
 tomate
 moto
 tele
 lata
 pelota
 pito
 tapa
 seta
 siete

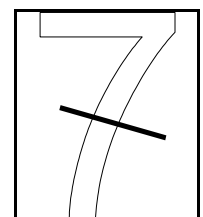
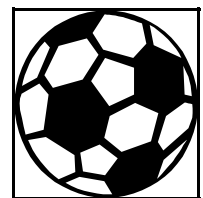



tomate



tela

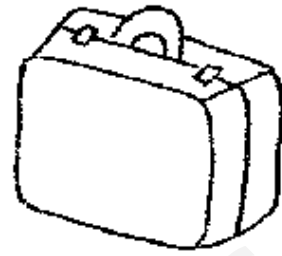

maleta



moto

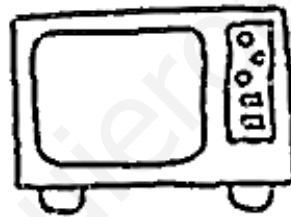

tele



lata



pito



seta



pelota

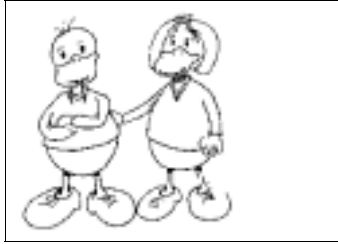

Mamá pata, papá pata



El patito se asea



Mamá pata asa tomates



Papá pata pela patatas



los ↔ las

las _ telas

los _ pitos

_____ sapos

_____ patos

_____ teles

_____ setas

_____ latas

_____ pelos

_____ sietes

_____ sopas

~~tomate~~ ~~tela~~ maleta tele pato
 moto pelota lata pito siete
 tapas setas Pepe seis polo pilas

__ a
tela

__ e
tomate

__ o

__ s



Leo...

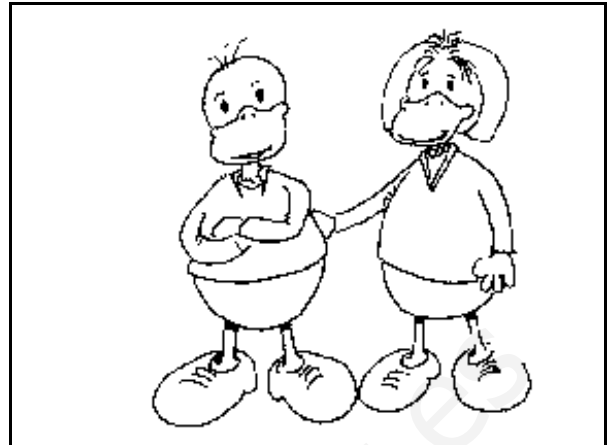

Papá pato. Mamá pata

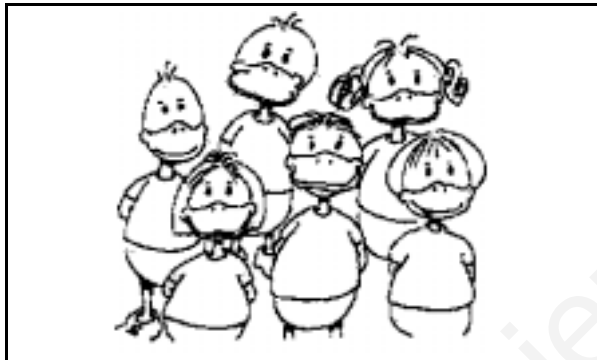

Los seis patitos



Mamá pata asa
tomates









Papá pato pela patatas

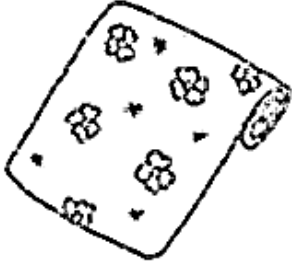
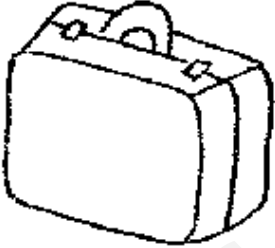

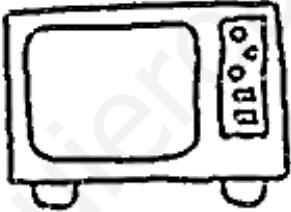
El patito se aseá





polo
 pipa
 paloma
 pala
 pila
 pie
 seis

tela
 tomate
 moto
 lata
 pelota
 pito
 tapa
 seta
 siete



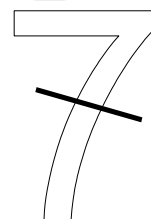
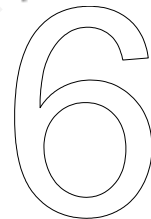

Papá pato pela patatas.
Mamá pata asa tomates.
Los seis patitos.
Mamá pata toma la moto.
Pepe suma siete más seis.
El patito se asea.
Mamá pisa el pie.
El pato pasea al sapo.



Handwriting practice area with multiple sets of horizontal lines (solid top and bottom lines, dashed middle line) for writing. Two small circles are present on the first two lines of the first set.



Tema 6	第六课	Unit 6
Papá pato, mamá pata.	鸭爸爸，鸭	Father duck, mother duck
Los seis patitos.	六个小鸭子	The six little ducks
Mamá pata asa tomates.	鸭妈妈烤番茄。	Mother duck roasts some tomatoes
Papá pato pela patatas.	鸭爸爸削土豆皮。	Father duck peels some potatoes
El patito se asea.	小鸭子在梳洗。	The little duck washes himself
		
Papá pato pela patatas.	鸭爸爸削土豆皮。	Father duck peels some potatoes
Mamá pata asa tomates.	鸭妈妈烤番茄。	Mother duck roasts some tomatoes
Los seis patitos.	六个小鸭子	The six little ducks
Mamá pata toma la moto.	鸭妈妈推摩托车。	Mother duck rides the motorbike
Pepe suma siete más seis.	贝贝做加法，7加6。	Pepe adds six plus six
El patito se asea.	小鸭子在梳洗。	The little duck washes himself
Mamá pisa el pie.	妈妈踩脚了。	Mum steps on the foot
El pato pasea al sapo.	小鸭子带癞蛤蟆散步。	The duck walks the toad



na ne ni no nu
an en in on un

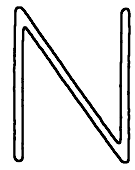

nene

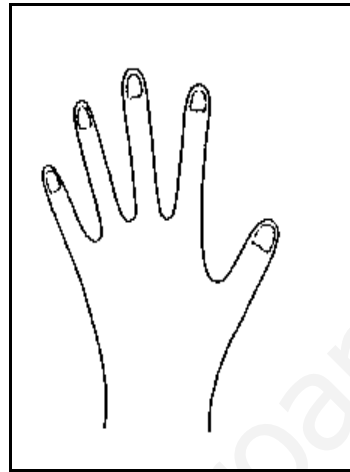

mano

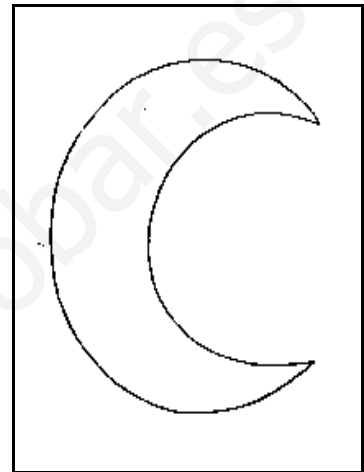

luna



nena



mono

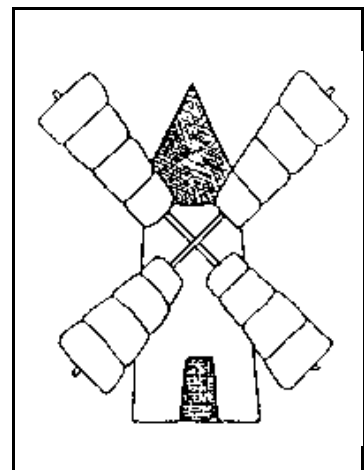

molino

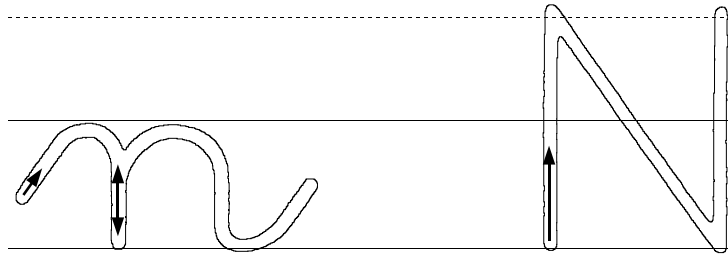

ma me ne me nu
am em im en un
Na Ne Ni Ne Nu

meme León memo limón
pino peine japon mano
salmón lana nata latón
puente pantalón nota
piano salón manta

Amita tiene un piano.
Antonio tiene un
pantalón.



Ma Ma Ma Ma Ma
Ma Ma Ma Ma Ma

ma ma ma ma ma

Mamá para es mamá

Papá para es papá

Tienen seis patitas

Tienen su mamá

El mamá tiene mamá

La lata tiene un tapón



Amita me se asusta



El oso pasa el puente

La mema toma melón

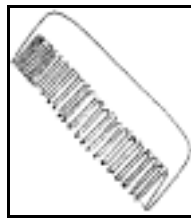

nene



luna

peine

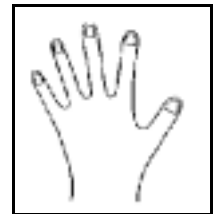

nena

león



mano

piano

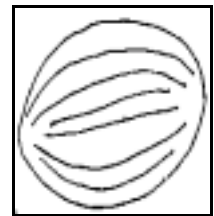

melón

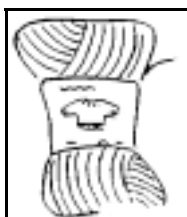

lana

limón

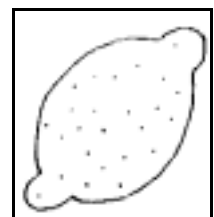

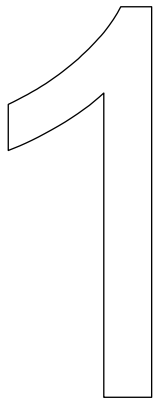

uno

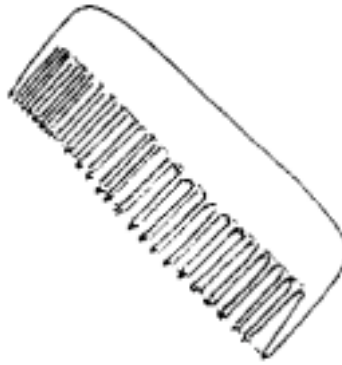

peine



enano



punto



pan

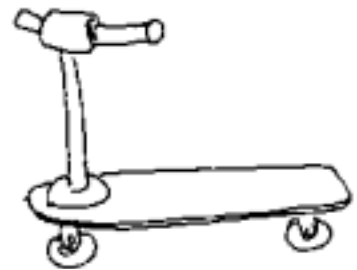

patinete



pantalón



pino



león



Esta es la pata Natalia



Este es el pato Antonio



Tienen seis patitos

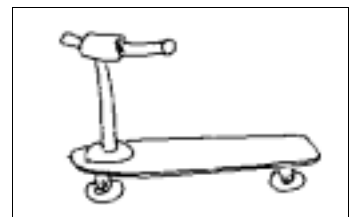

Natalia monta en su patín



un ↔ una

un _ sapo

una nena

_____ limón

_____ pato

_____ tele

_____ seta

_____ lata

_____ pelo

_____ siete

_____ sopa

~~antena~~ puente pantalones manta
 motín tinta menta limón patín
 melón pan pinta talón mente
 pinta piensa

__ an __
antena

__ en __

__ on __

__ in __



Leo...

El oso
Nino

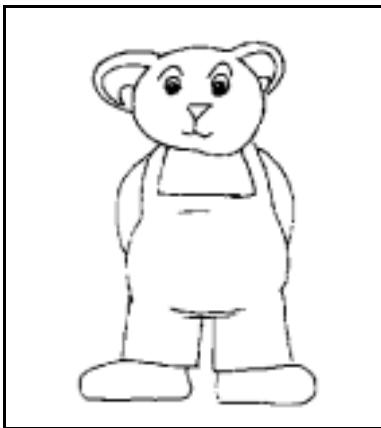
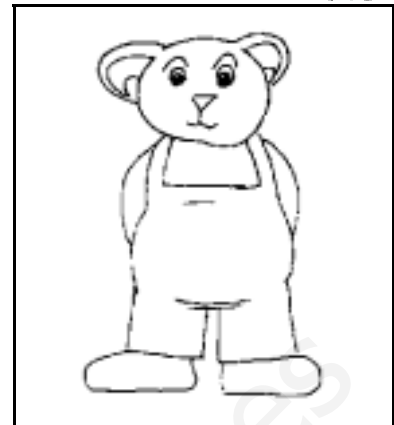

Este oso es
Nino



Nino se peina

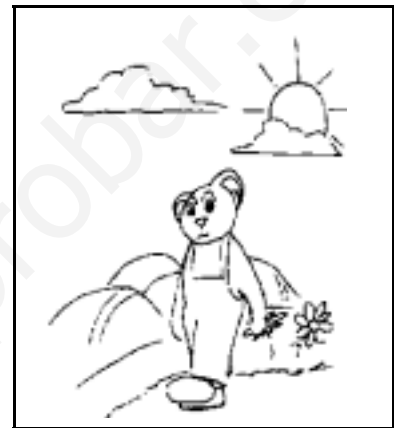

Nino pasea

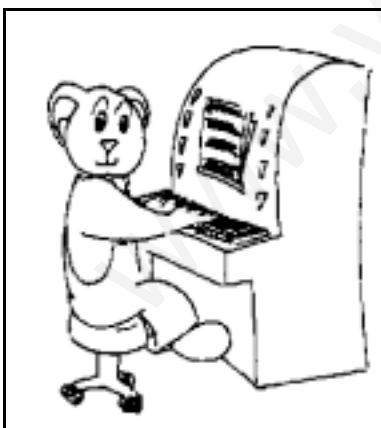

Nino tiene
un piano



Toma sopa,
tomate, pan



Nino patina
en el
patinete

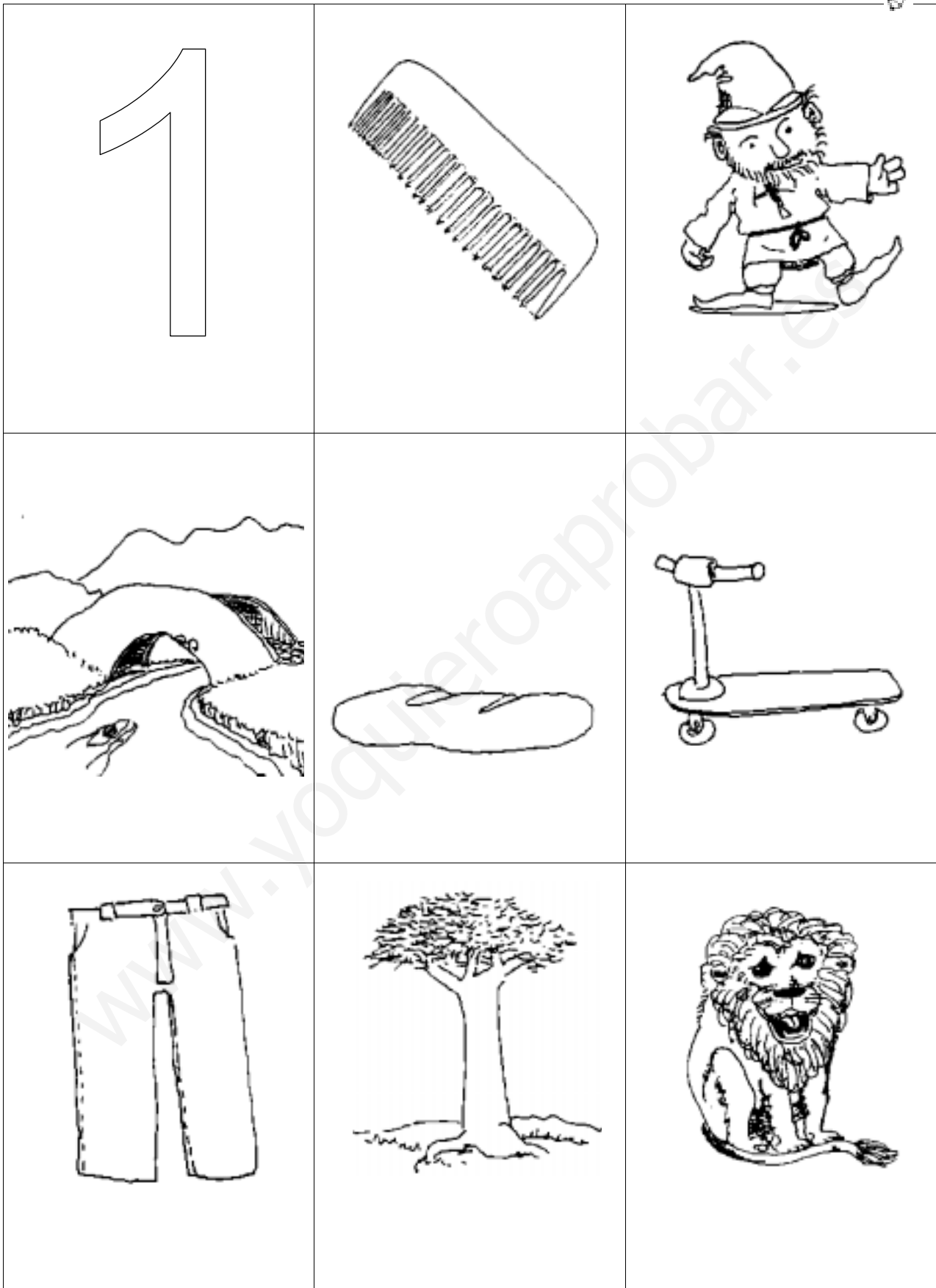



Este  es Nino

Handwriting practice lines consisting of a solid top line, a dashed middle line, and a solid bottom line.



Emi usa un 

Handwriting practice lines consisting of a solid top line, a dashed middle line, and a solid bottom line.



Luis sale al 

Handwriting practice lines consisting of a solid top line, a dashed middle line, and a solid bottom line.



Nino tiene un 

Handwriting practice lines consisting of a solid top line, a dashed middle line, and a solid bottom line.



Antonio, ponte el 

Handwriting practice lines consisting of a solid top line, a dashed middle line, and a solid bottom line.



Antonio tiene un pantalón.
Natalia monta en su patín.
El mono salta a los asientos.
Antón toma melón.
Elia toma limón.
Anita no se asusta.
El enano se peina.
Nino tiene un piano.



Handwriting practice lines with a watermark: www.yoquieroaprobar.es



Tema 7

第七课

Unit 7

El oso Nino.	一个叫尼诺的小熊	Nino the Bear
Este oso es Nino.	这个小熊叫尼诺。	This bear is Nino
Nino se peina.	尼诺梳头。	Nino brushes his hair
Nino pasea.	尼诺散步。	Nino walks
Nino tiene un piano.	尼诺有一架钢琴。	Nino has a piano
Toma sopa, tomate, pan.	喝汤，吃番茄和面包。	He eats some soup, tomatoes and bread
Nino patina en el patinete.	尼诺滑滑板。	Nino rides the scooter



Antonio tiene un pantalón.	安东尼奥有条裤子。	Antonio has a pair of trousers
Natalia monta en su patín.	纳塔丽娅上了滑板。	Natalia rides her scooter
El mono salta a los asientos.	猴子在座位上跳来跳去。	The monkey jumps onto the seats
Antón toma melón.	安东吃哈密瓜。	Anton eats some melon
Elia toma limón.	爱丽娅吃柠檬。	Elia eats some lemon
Anita no se asusta.	阿尼塔不怕。	Anita doesn't get frightened
El enano se peina.	小矮人梳头。	The dwarf combs his hair
Nino tiene un piano.	尼诺有一架钢琴。	Nino has a piano



da de di do du
ad ed id od ud



nido

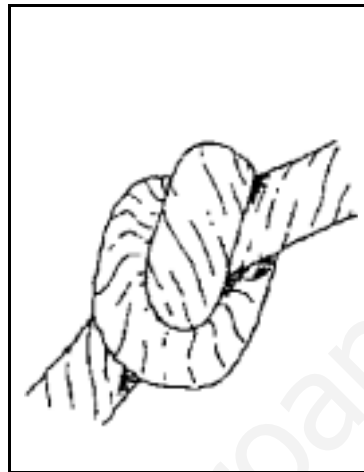

nudo

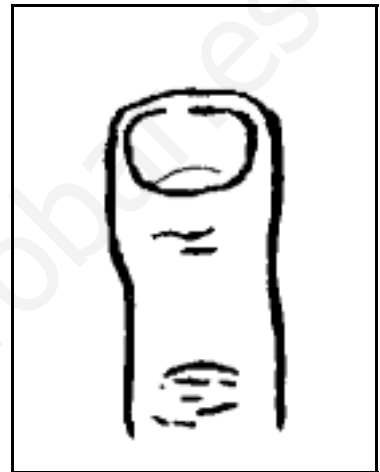

dedo

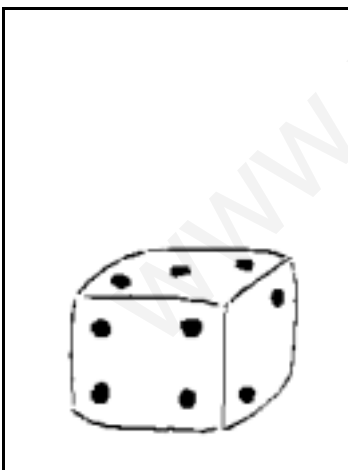

dado

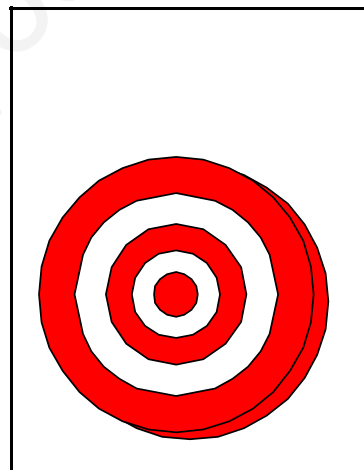

diana

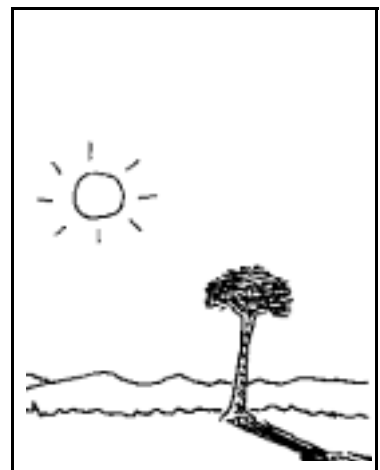

día

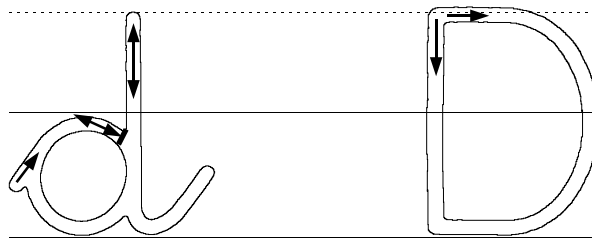

da de di do du

ad ed id od ud

Da De Di So Du

dado dedo Daniel mide

duende dos dedal dalia

tienda diente pedales

espada sandalia

pendiente salud dieta

senda moneda dátiles

panda duende indio

diana diminuto



Da De Di De Du

da de di de du

Antena nada

Dama anda al sol

Tema día dátil

La diadema de Navidad

El meme tema potato

Ama tema un pelo



Dame medio tomate



El oso usa la pomada

Lola tiene miedo

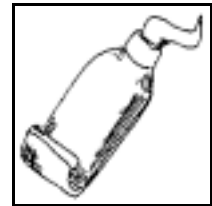
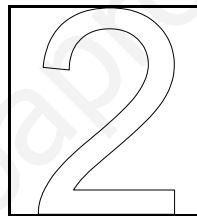
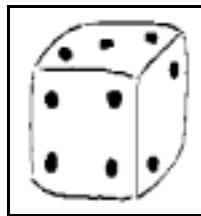
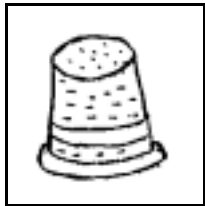

dedal

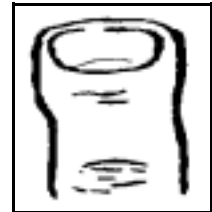

dedo

dado

dos

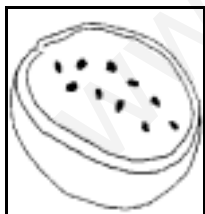

pomada

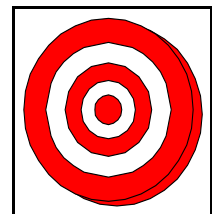

nido

sandía



nudo

diana

moneda





dalia



dominó

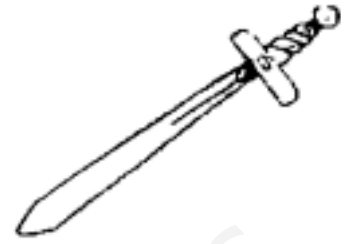

espada



duende



dientes



pasta



moneda



sandía

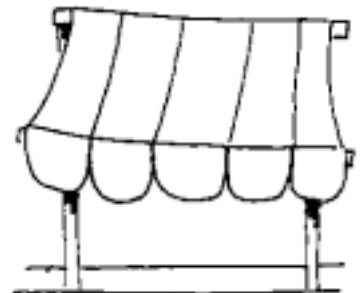

toldo



A Adela le duele el diente



Daniel tiene un dedo malo



Mamá le pone pomada



Papá tiene un dominó



un ↔ dos

un_ diente

dos nidos

_____ dedos

_____ pato

_____ tomate

_____ indios

_____ limón

_____ manos

_____ toldos

_____ siete

_____ nidos

_____ latas

Nino	Natalia	Lola	Antonio	Lolo
	Paula	Luisa	Emilio	



___ o
Nino

___ a



Leo...

El mono
de Daniel



Daniel es un
duende



Tiene un
mono

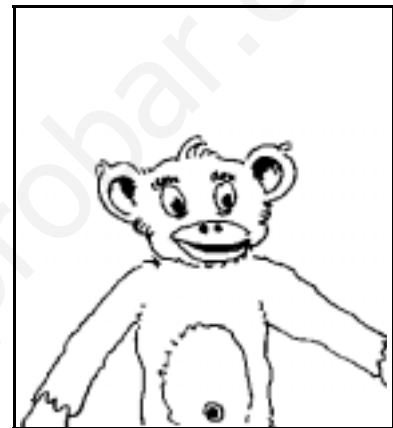

Es Monín

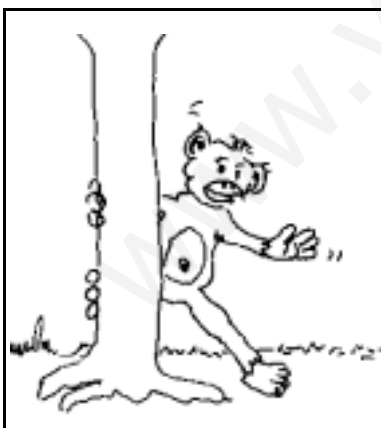

Monín salta
en el pino

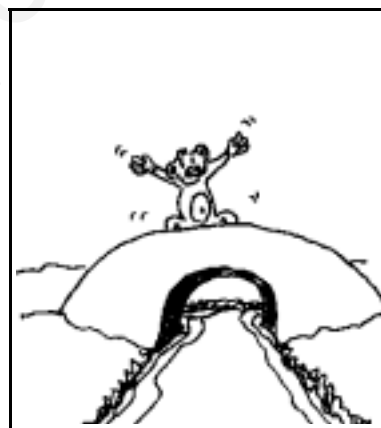



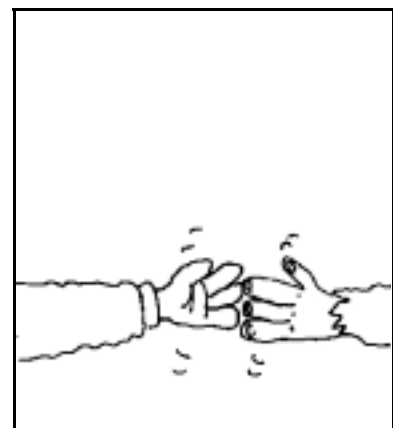

Monín salta
en el
puente

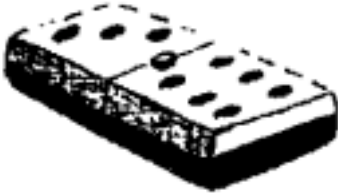
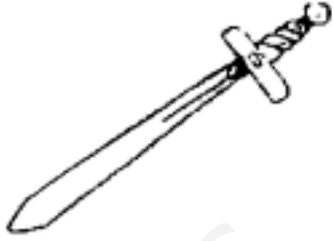

Dame la
mano, Monín

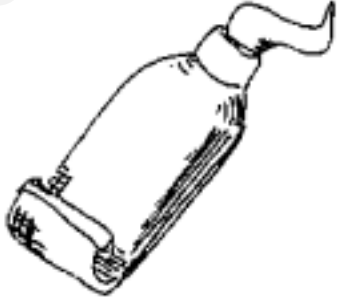



La  de Daniel

.....

.....

Dame medio 

.....

.....

Dame todo el 

.....

.....

Natalia tiene un 

.....

.....



, ponte el pantalón de



.....

.....



El indio toma melón.
Antonio nada en el puente.
Ana tiene un polo en la mano.
La paloma tiene dos alas.
Ali oía la tele de mamá.
Papá peina a Pepe.
Me duele el dedo.
La sopa está en la mesa.



Handwriting practice lines with a watermark: www.yoquieroaprobar.es



alas. paloma tiene La

La paloma tiene alas.



oía Lolo tele. la



peina Pepe. a Papá



dedo. duele Me el



está mesa. La en sopa la

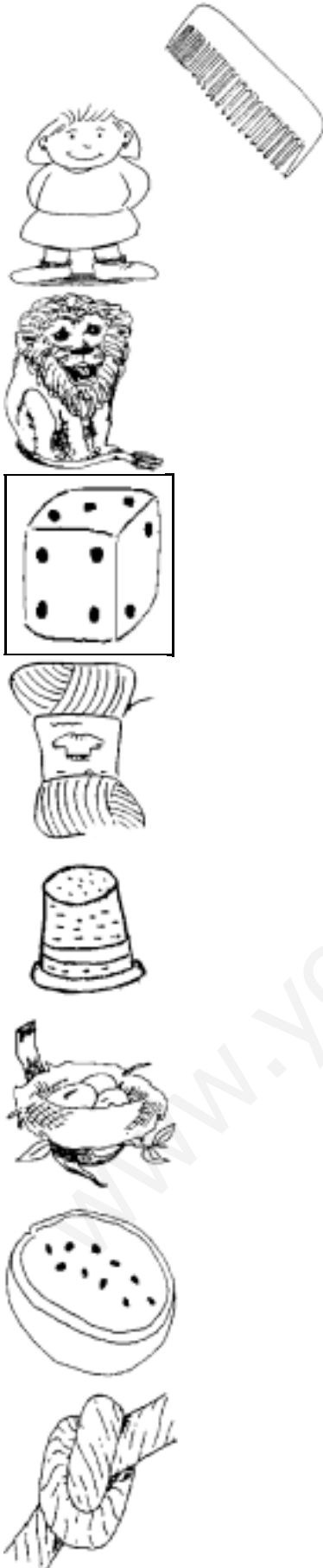

nene
 luna
 peine
 nena
 león
 mano
 melón
 lana
 limón
 dedal
 dedo
 dado
 dos
 pomada
 nido
 sandía
 nudo
 diama





Tema 8	第八课	Unit 8
El mono de Daniel.	达尼埃尔的猴子	Daniel's monkey
Daniel es un duende.	达尼埃尔是个精灵。	Daniel is an imp
Tiene un mono.	他有个猴子。	He has a monkey
Es Monín.	叫毛宁。	It is called Monin
Monín salta en el pino.	毛宁跳到松树上。	Monin jumps on the pine
Monín salta en el puente.	毛宁跳到桥上。	Monin jumps on the bridge
Dame la mano, Monín.	拉住我的手，毛宁。	Give me your hand, Monin



El indio toma melón	印第安人吃哈密瓜。	The indian eats some melon
Antonio nada en el puente.	安东尼奥在桥下游泳。	Antonio swims under the bridge
Ana tiene un polo en la mano.	安娜手上拿了根冰棍。	Ana is holding an ice lolly
La paloma tiene dos alas.	鸽子有两个翅膀。	The dove has two wings
Alí oía la tele de Mamá.	阿里听着妈妈的电视机声	Alí listened to mom's TV
Papá peina a Pepe.	爸爸给贝贝梳头。	Dad combs Pepe's hair
Me duele el dedo.	我手指头痛。	Mi finger hurts
La sopa está en la mesa.	汤在桌子上。	The soup is in the table

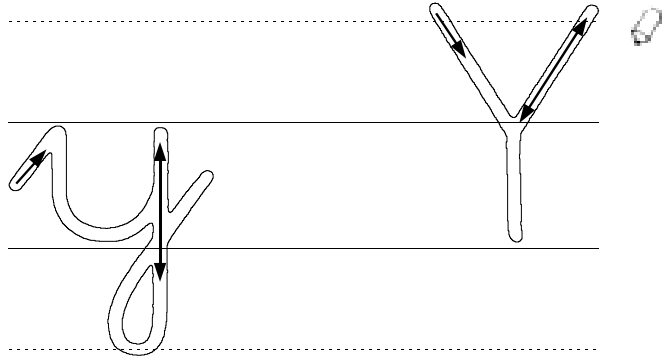

A E I Y O U a e i y o u
a e i y o u A E I Y O U



La Le Li Le Lu la le li lo lu
Alí y Lola, Lulu y Flia



Ma Me Mi Mo Mu y mamá
ma me mi mo mu y Emilia



Sa Se Si So Su y el Sol
sa se si se su y Luisa



Papá y Pepe toman el auto



Pa Pa Pi Pe y pito a la
 pa pe pi pe pi y pisa el pie



Ta Te Ti To Tu y toma la tele
 ta te ti to tu y pela patatas



Na Ne Ni No Nu y el
 na ne ni no. Pam y tomate



Da De Di Do Du mide y
 da de di do du y el indio Pepe

Amén y Navidad nadam en el
 puenis.

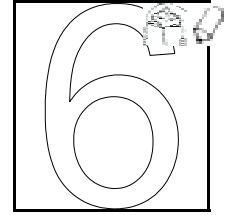
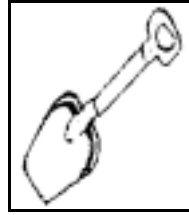
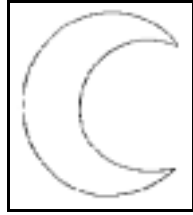
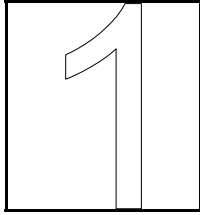

luna

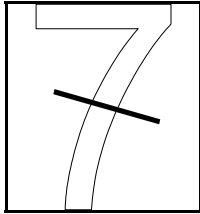

pala



uno

seis

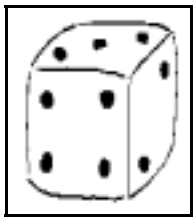

siete

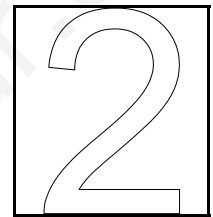

pie

dedal

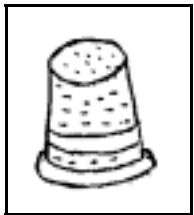

dedo



dado

dos



romada

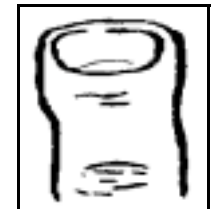

nido

sandía



nudo

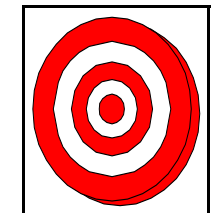

diana

moneda

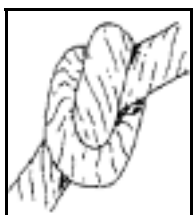

toldo

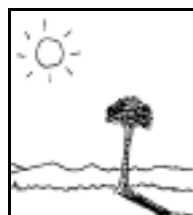

día

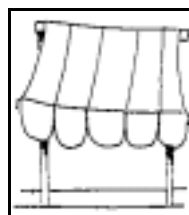



Papá pato pela _____



Daniel tiene un _____ malo

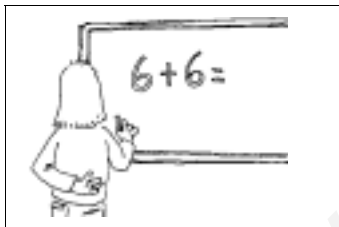

Luis suma _____ y _____



Lulú lame la _____



~~Lola~~ sol puente diana sopa
 Luisa piano lima nene ala tomate
 miel siete pino luna toma duende
 molino pie maleta espada oso día
 seis momia amapola tupé Emilio
 ala dedo todo

S

P

T

M

D

L
Lola



La  de Sam y Emilia

Dame un  y media 

Toma  de 

Natalia monta en su 

Pepe y Lulú saltan en el 



PEPE

- ¡Pom, pom! Soy Pepe



- Pasa, pasa, Pepe. ¿Sopa, Pepe?



- Sí mamá, dame sopa.



- ¿Toses, Pepe?



- Sí mamá, toso.



- Pues tómate esto. ¿Se te pasa?.



- Sí, se me pasa.





Tema 9	第九课	Unit 9
¡Pom, pom! Soy Pepe.	嘭，嘭，我是贝贝。	Knock, knock!, I'm Pepe
Pasa, pasa, Pepe. ¿Sopa, Pepe?	进来，进来，贝贝。喝汤	Come in, come in, Pepe. Some soup, Pepe?
Sí, mamá. Dame sopa..	喝汤，妈妈。给我汤吧。	Yes, mum, give me some soup
¿Toses Pepe?	贝贝，你咳嗽了？	Are you coughing, Pepe?
Sí mamá, toso.	是的，妈妈，我咳嗽了。	Yes, mun, I'm coughing
Pues tómate esto. ¿Se te pasa?	把这个吃了。好一点没有？	Then have this. Are you better?
Sí, se me pasa.	好一点了。	Yes, I'm better.



ha he hi ho hu
ah eh ih oh uh

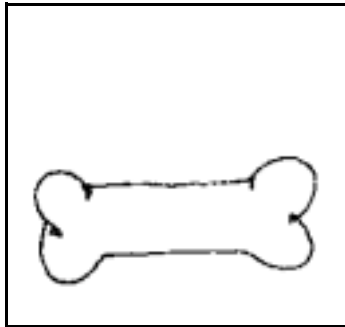
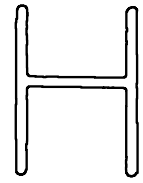
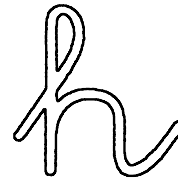

hueso



helado



hada

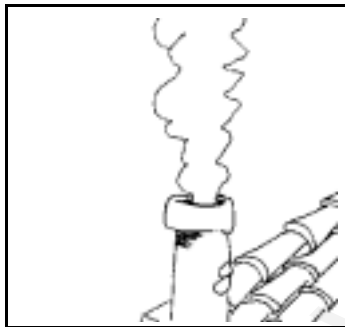

humo

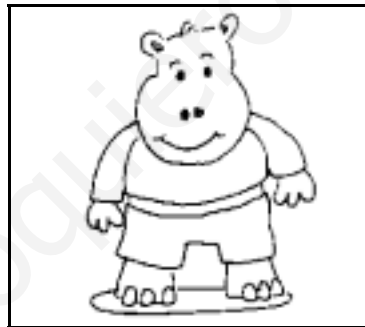

hipopótamo

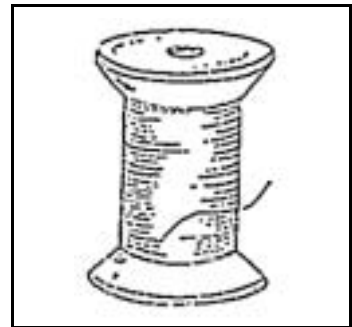

hilo

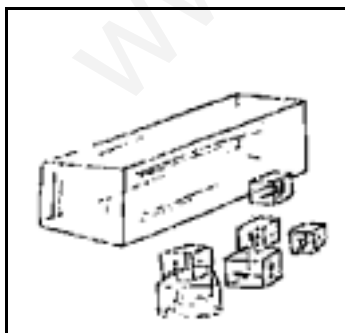

hielo



hiena



¡Hola!

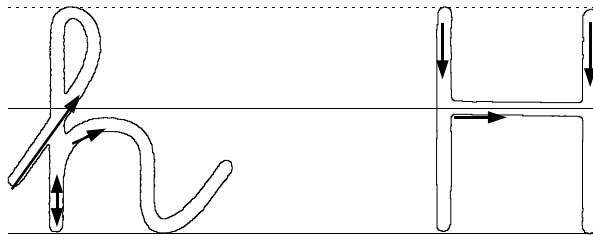

ha he hi ho hu

ah eh ih eh uh

Ha He Hi Ho Hu

hueso helado hada

humo hilo hipopótamo

hielo hiema ¡Hola! Hua

Ahmed tema helados

Hay humo ahí

El hada Anita es

diminuta



Ha He Hi Ho Hu

ha he hi ho hu

Hoy Lola nada en el puente

Hua toma helado

El hueso de Lulú

Alí se pone hielo en la mano

Te doy la diadema de Natalia

El mono toma patata y melón

Tiene un pelo y un helado

Doy medio tomate al oso

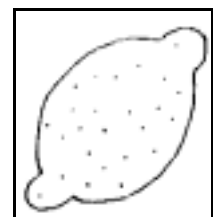
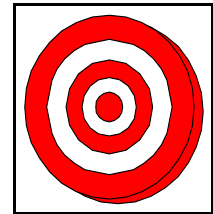
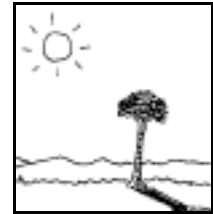
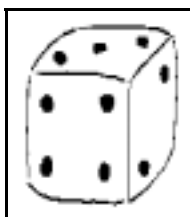
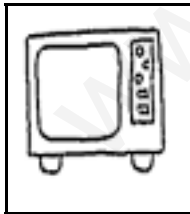
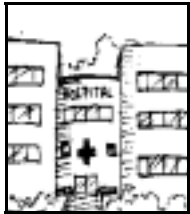
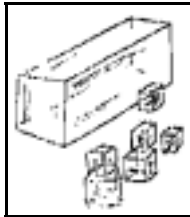
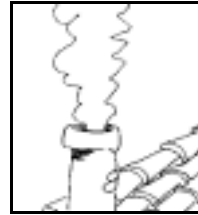

el hueso
 el humo
 el hada
 el hilo
 el helado
 el hielo
 la hiena
 el hospital
 el hipopótamo
 el día
 la tele
 el polo
 el pito
 la diana
 el dado
 el limón

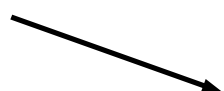

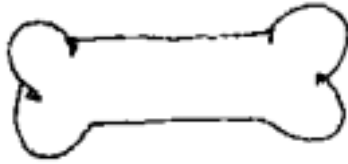

hueso



helado



hada



humo

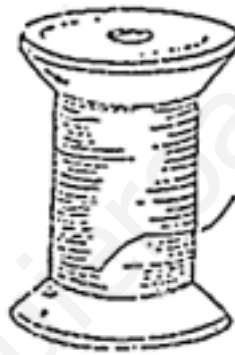

hilo



hipopótamo

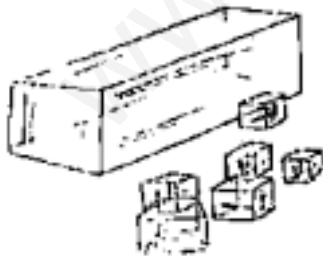

hielo



hiema



¡Hola!



Hoy el hipopótamo se muda



El hueso de la hiena



Hua pone pomada a Sam



Emilio pone hielo al melón



el ↔ la

el diente
 _____ hada
 _____ helado
 _____ limón
 _____ hospital
 _____ tapa

la pata
 _____ hueso
 _____ hiena
 _____ mano
 _____ pelota
 _____ humo

~~limón~~ limones helados helado pito
 pitos hospital hospitales



un ...
limón

mas ...



 <p>Leo...</p>	<p>El hada Anita</p>	
		
<p>Anita es diminuta</p>	<p>Toma helados y más helados</p>	<p>Se pone malita</p>
		
<p>Mamá hada la mima</p>	<p>Hay humo ahí</p>	<p>Anita tose</p>





El  sale de ahí

.....

.....

Hua huele el 

.....

.....

Dame todo el pan y ponle 

.....

.....

Tatiana tiene media 

.....

.....



pone hielo en su



.....

.....



Esta lata huele muy mal.
Ali toma té y pastas.
Hua tiene un polo en la mano.
La momia no tiene hielo.
Sam oía la tele de papá.
El hada Anita toma helados.
Hoy me duele la mano.
Soy Emi y soy muy alta.



Handwriting practice area with multiple sets of horizontal lines (solid top and bottom lines, dashed middle line) for writing practice.



Tema 10	第十课	Unit 10
El hada Anita	这是仙女阿尼塔	Anita the fairy
Anita es diminuta.	阿尼塔很小很小。	Anita is very little
Toma helados y más helados.	吃冰淇淋，吃更多的冰淇淋	She eats more and more ice cream
Se pone malita.	他病了。	She falls ill
Mamá hada la mima.	仙女妈妈宠爱她。	Mother fairy cuddles her
Hay humo ahí.	那里冒烟。	There's some smoke there.
Anita tose.	阿尼塔咳嗽。	Anita coughs
		
Esta lata huele muy mal.	这个罐头味很难闻。	This can smells very bad
Alí toma té y pastas.	阿里喝茶，吃点心。	Alí eats some tea and cookies
Hua tiene un polo en la mano.	华手上拿根冰棍。	Hua is holding an ice lolly
La momia no tiene hielo.	木乃伊没有冰。	The mummy doesn't have any ice
Sam oía la tele de papá.	山姆听着爸爸的电视机声。	Sam listened to dad's TV
El hada Anita toma helados.	仙女阿尼塔吃冰淇淋。	Anita the fairy eats ice cream
Hoy me duele la mano.	今天我手痛。	My hand hurts today
Soy Emi y soy muy alta.	我是艾密，我很高。	I'm Emi and I'm very tall



ca co cu
ac oc uc

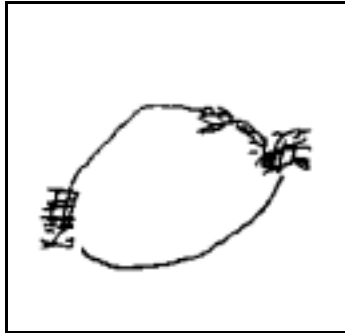
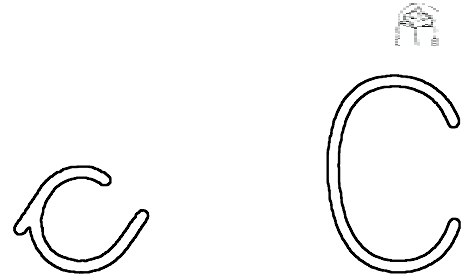

coco



casa

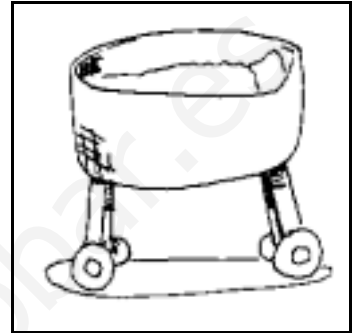

cuna

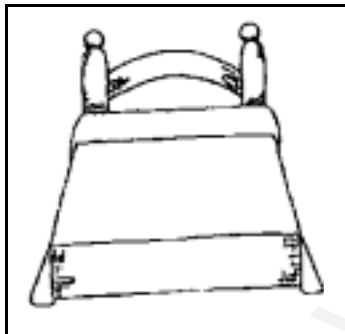

cama

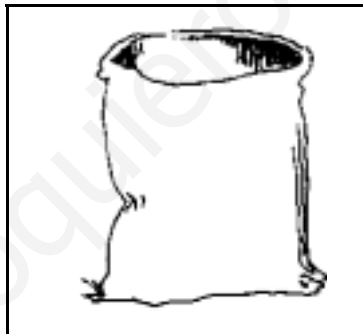

saco



copa



campana

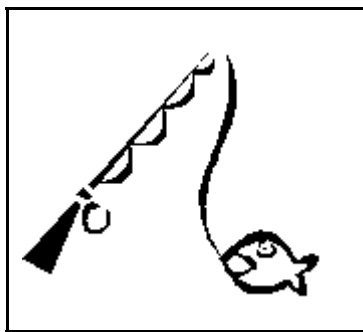

pescado

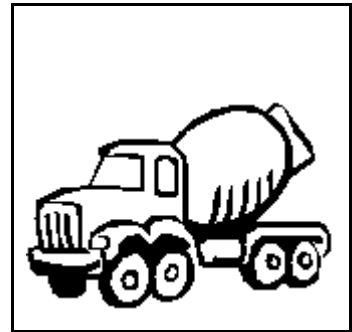

camión

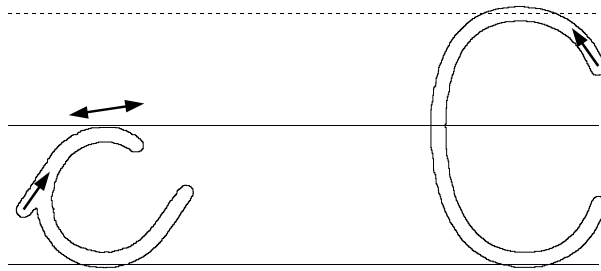

ca ce cu

ac ec ic ec uc

Ca Ce Cu

cepa casa ceco case camisa
campana cadena cama sace
camión música camiseta
canoa canto cuento camino
cacahuetes columpio comida
peccado escuela manteca

Alí come cacahuetes

Sam se pone una camiseta

Tomás come pescado y pan

Tomás cuida a Tatiana



Ca Ce Cu

ca ce cu

Hua cuida la escuela

Lola pone a Pepe en la cuna

Teca la campana en la escuela

Hoy la comida es de pescado

Como pan con manteca

Cuenta un cuento de hadas

Oí la música de la campana

La cadena del camión



¿Tienes la sal?

Si, ahí está la sal

¿Comes pipas?

No, como cacahuetes



Tatiana
la cama
el saco
el pescado
la campana
el camión
la cuna
el coco

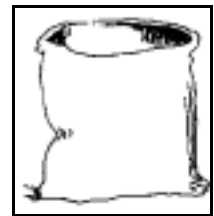
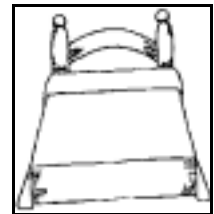

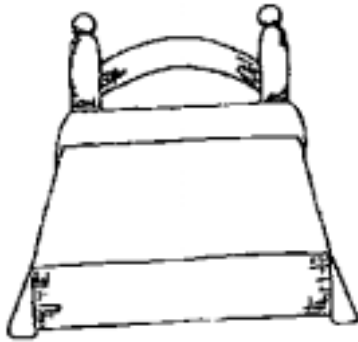

cama



camión



cepillo



casa



cece



copa



cuna



saco



pescado



Hua cuida la cuna de Pepe

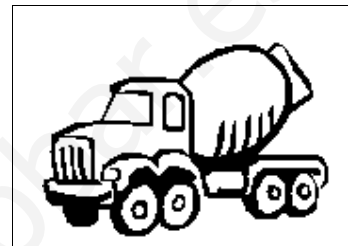

El camión no tiene pescado



El mono come cacahuètes



Lola lee un cuento de hadas



los - las

los dientes

las patatas

_____ copas

_____ camas

_____ cadenas

_____ caminos

_____ pescados

_____ comidas

_____ canoas

_____ sacos

_____ cuentos

_____ escuelas

camas	limones	helados	camiones	panes
dátiles	cacahuets	escuelas	sandías	patatas

hoy como ...

limones





 <p>Leo...</p>	<p>El hipopótamo Hip-up</p> 
	
<p>Hip-up es un hipopótamo</p>	<p>Es muy comilón</p>
	
<p>Come: cacahuètes, cocos, cacao, nata y helados</p>	<p>Como come tanto tiene hipo: hip, hip, hip...</p>

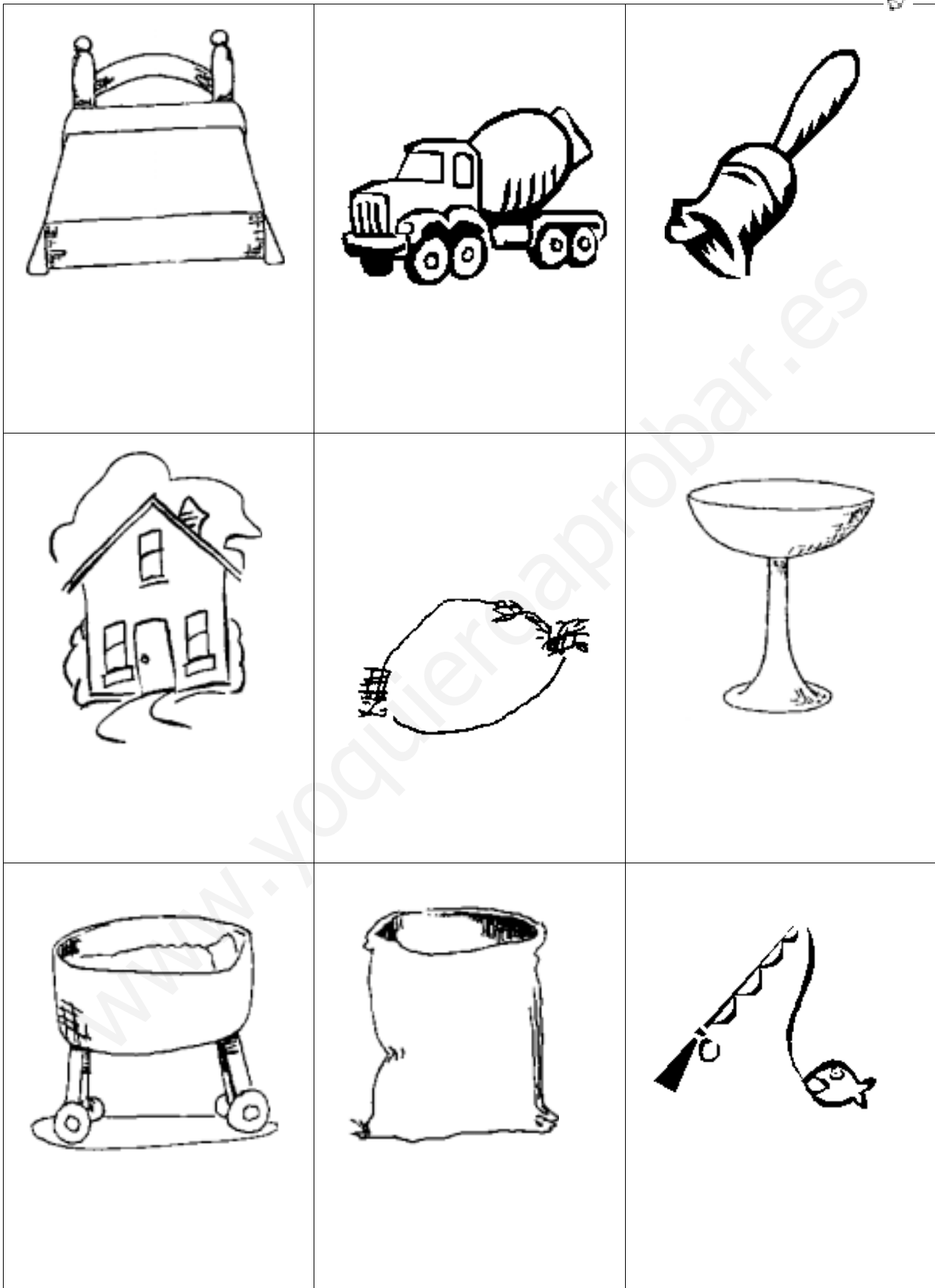



El  sale del puente

Hua huele el 



, dame el cuento de hadas

Alí tiene la  en la escuela

La camisa de Sam es de





La cadena del camión.
Oí la música de la campana.
Lola pone a Pepe en la cuna.
Hoy la comida es de pescado.
Sam oía música en el salón.
Cuenta un cuento de hadas.
Hoy me como unos cacahuets y unos dátiles.
Estas pipas están muy saladas y no las como.



Handwriting practice area with multiple sets of horizontal lines (solid top and bottom lines, dashed middle line) for writing.



Tema 11	第十一课	Unit 11
El hipopótamo Hip-up.	河马西帕普	Hip-Hup the hippo
Hip-up es un hipopótamo.	西帕普是只河马。	Hip-Hup is an hippo
Es muy comilón.	他很贪嘴。	He is a big eater
Come: cacahuets, cocos, cacao, nata, y helados	他吃花生、椰子、可可、奶	He eats: peanuts, coconuts, cocoa, cream and ice-cream
Como come tanto, tiene hipo: hip,hip,hip...	他吃得太多，打嗝了，嗝，	Because he eats so much he has hiccups
		
La cadena del camión	卡车的链条	The truck chain
Oí la música de la campana.	我听见钟声。	I heard the bell's music
Lola pone a Pepe en la cuna.	劳拉把贝贝放进摇篮。	Lola puts Pepe in the cradle
Hoy la comida es de pescado.	今天午餐是鱼。	Today the food is fish
Sam oía música en el salón.	山姆在客厅听着音乐。	Sam listened to the music in the salon
Cuenta un cuento de hadas.	讲一个仙女的故事。	Tell a fairy history
Hoy me como unos cacahuets y dátiles.	今天我吃一些花生和蜜枣。	Today I eat some peanuts and dates
Estas pipas están muy saladas y no las como.	这些瓜子太咸了，我不吃。	These seeds are too salty and I won't eat them



que qui

qu

Qu

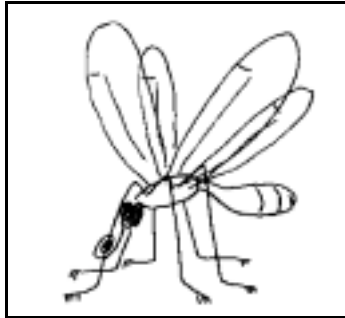

mosquito



máquina

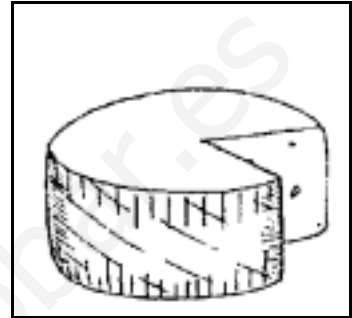

queso

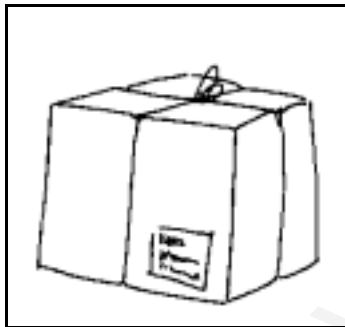

paquete



esquimal

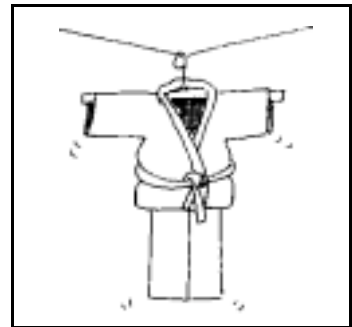

quimono



Quique

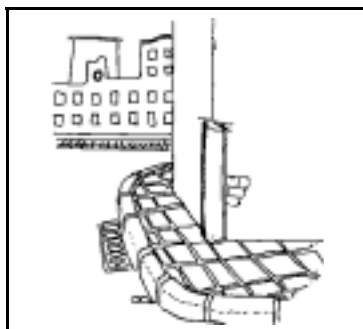

esquina



equipo

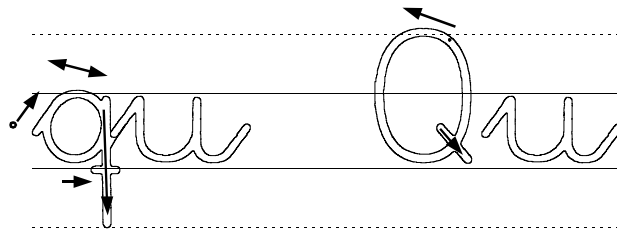

que qui
Que Qui

que qui que
Que Qui Que

paquete queso equipo esquima
Quique esquimal máquina
mosquito quimono

Un paquete de queso
El equipo de tenis
Quique tiene un quimono
El cuento es de esquimales
El mosquito me pica en el
dedo



Que Qui

que qui

El mosquito pica a Quique

El esquimal se pone el quimono

La máquina se cae al suelo

Como queso con pan

Me caí en la esquina

Cuenta con el equipo

El oso pasea con el esquimal

¿En qué piensas?



¿En qué piensas?

Pienso que me duele el dedo

¿Te picó el mosquito?

Sí, me picó en el dedo

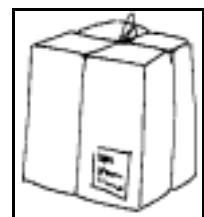
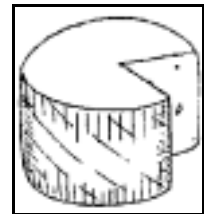
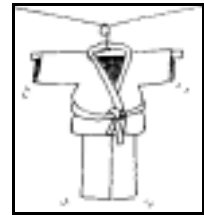
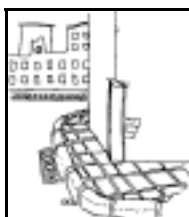
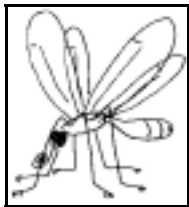

el queso
 el mosquito
 la máquina
 el paquete
 el esquimal
 el quimono
 Quique
 el equipo
 la esquina

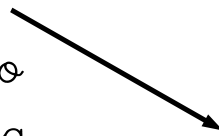



equipo



esquimal



máquina

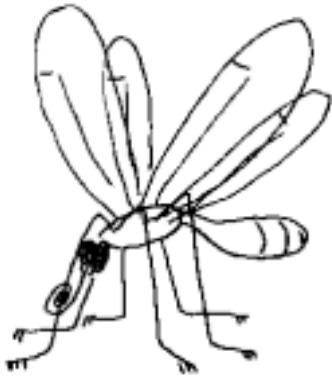

mosquito

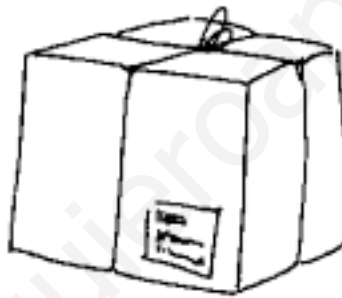

paquete

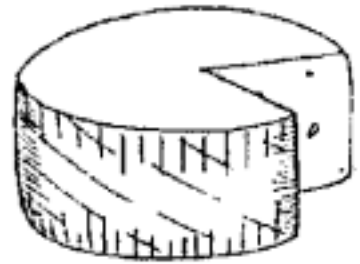

queso



químono



Quique



esquí

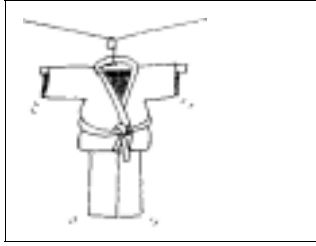

Quique cuida su kimono

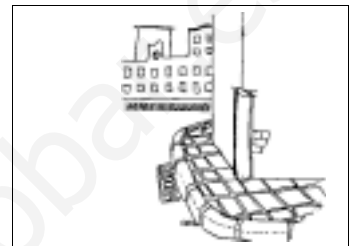

El camión pasa la esquina



El equipo de Quique

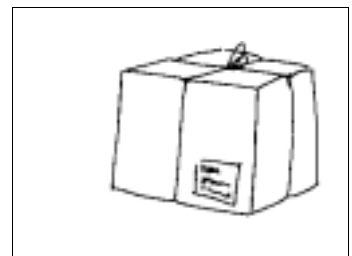

El paquete tiene un queso



mi - tus

mi diente
 _____ copas
 _____ camisa
 _____ pescado
 _____ canoas
 _____ cuentos

tus palas
 _____ cama
 _____ paquetes
 _____ comidas
 _____ quimono
 _____ escuela

~~melocotones~~ camisas médicos cacahuetes
 casas quesos quimonos patatas cuentos

hoy como ...
melocotones





 <p>Leo...</p>	<p>El paquete de Quique</p>	
		
<p>Toma, Quique, un paquete ¿Qué es?</p>	<p>¿Un queso? No, no</p>	<p>¿Un quimono? No, no</p>
		
<p>¿Una máquina? No, no</p>	<p>¡Es una cometa!</p>	<p>Quique sale con su cometa</p>

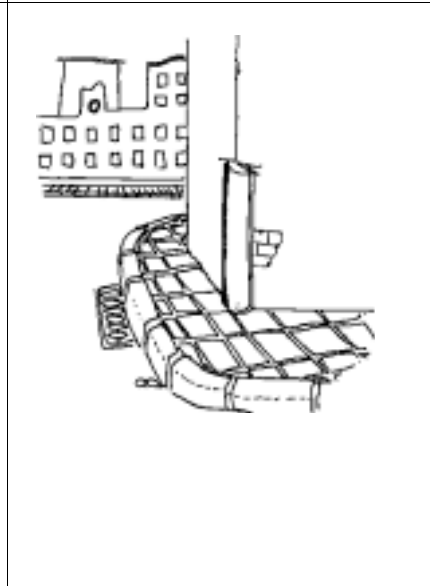
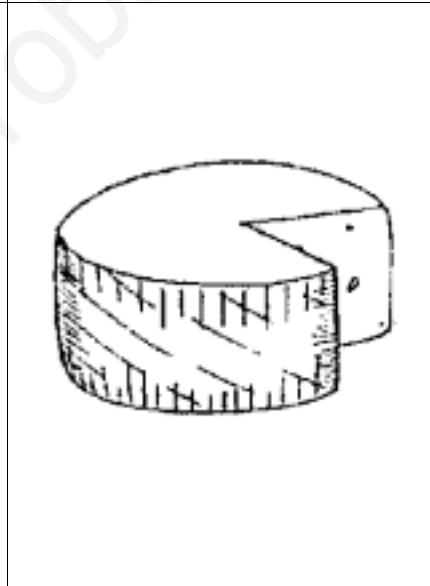
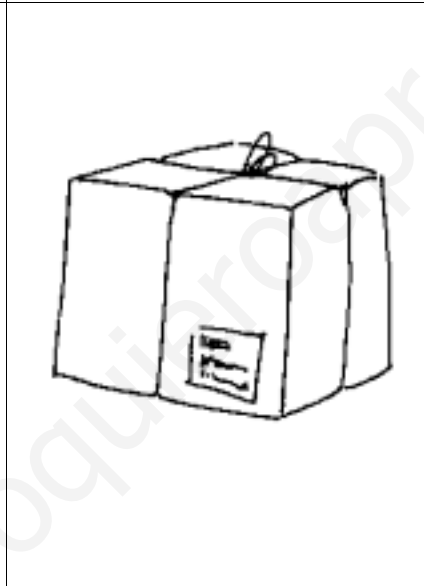
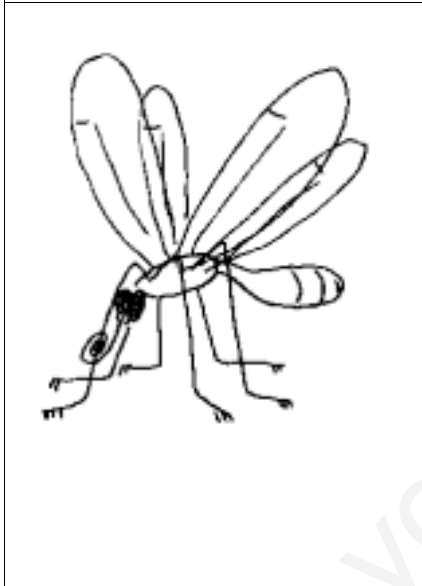
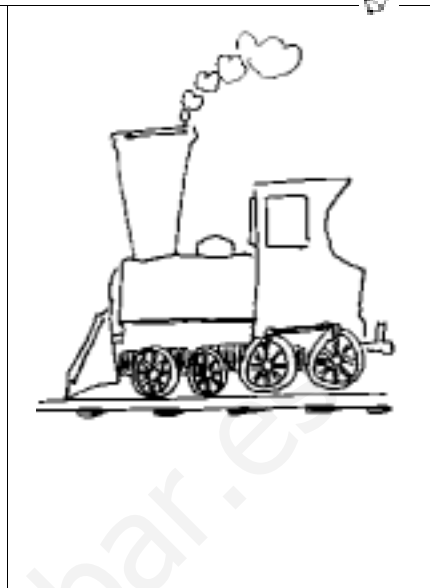



Quique tiene una



Hua seca el





come pan con



La  es de Hu y de Sam

Emi pasa la



de su





Natalia tiene un patito.
Asia se alisa el pelo con el peine.
Pepe tiene un mono con quimono.
Luis pone un quitasol en la casa.
Quique come cacahuètes con pan.
El médico le pone pomada en el dedo malo.
El saco tiene cocos y patatas.
El esquimal espía al oso.



Handwriting practice area with multiple sets of horizontal lines (solid top and bottom lines, dashed middle line) for writing practice.



Tema 12	第十二课	Unit 12
El paquete de Quique.	奇盖的包裹	Quique's package
Toma, Quique, un paquete. ¿Qué es?	奇盖，拿着，包裹。是什么	Here you are, Quique. A package. What is it?
¿Un queso? No, no.	奶酪？不是，不是。	Is it a cheese? no
¿Un kimono? No, no.	和服？不是，不是。	Is it a kimono? no
¿Una máquina? No, no.	机器？不是，不是。	Is it a machine? no
¡Es una cometa!	是个风筝！	It is a kittle!
Quique sale con su cometa.	奇盖拿着风筝出去了。	Quique goes out with his kittle



Natalia tiene un patito.	纳塔丽娅有个小鸭。	Natalia has a little duck
Asia se alisa el pelo con el peine.	阿西娅用梳子把头发梳直。	Asia smooths her hair with the comb
Pepe tiene un mono con kimono.	贝贝有一个穿和服的猴子。	Pepe has a monkey with a kimono
Luis pone un quitasol en la casa.	路易斯在家里放了一把遮阳	Luis puts an awning in the house
Quique come cacahuets con pan.	奇盖吃花生和面包。	Quique eats some peanuts with bread
El médico le pone pomada en el dedo malo.	医生在他的病指上涂上药	The doctor puts ointment in his bad finger
El saco tiene cocos y patatas.	麻袋里有椰子和土豆。	The sack has some coconuts and potatoes
El esquimal espía al oso.	爱斯基摩人监视着熊。	The skimo stalks the bear



ca que qui co cu
Ca Que Qui Co Cu

C

qu



casa

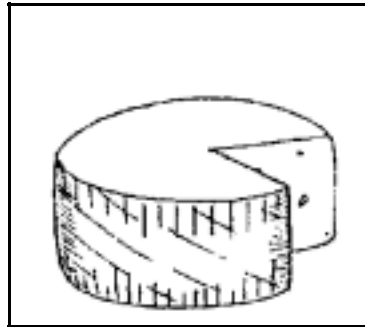

queso

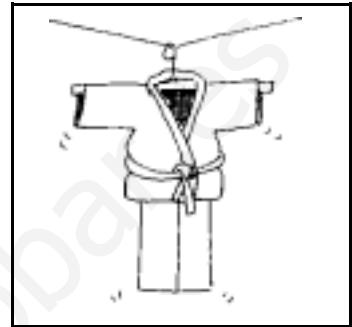

quimono

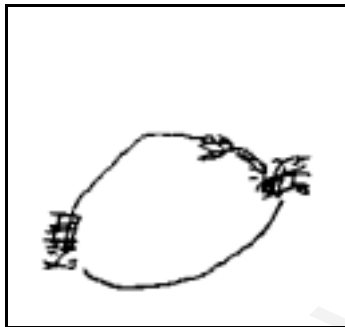

coco

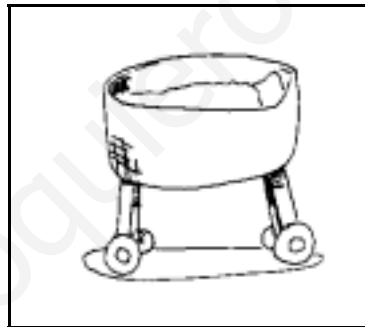

cuna

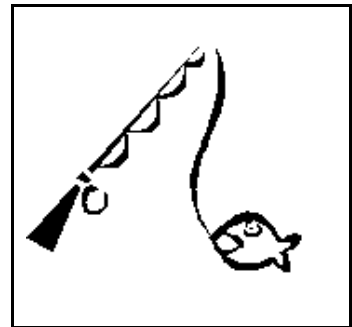

pescado

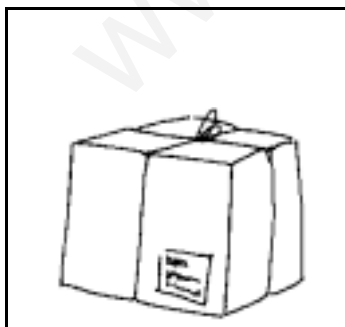

paquete



equipo

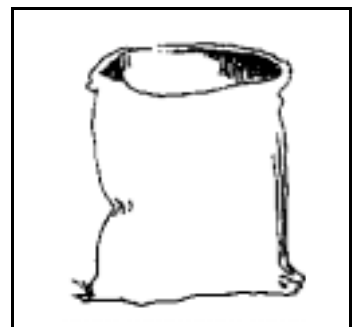

saco



ca que

ca que qui ce cu

Ca Que Qui Ce Cu

queso mosquito cometa paquete

Quique máquina equipo

esquimal cama maqueta

coqueta mequeta esquina

estanque camisa quitasol

quinqué melocotón manteca

médico medicamento

columpio comilón camino

pescado escuela cacahuetes

campana casa sace cece copa

cuce cucú

Toca el cucú de Quique



Ca Que Qui Ce Cu

ca que qui ce cu

La cometa de Quique

La cama del esquimal

La máquina del cohete

El helado de coco

Caí en la esquina de mi casa

Cuenta con el equipo de Pato

La mosca pica al esquimal

¿Qué te pasa?



¿Qué te pasa?

Me duele la mano

¿Te picó el mosquito?

No, me caí al suelo

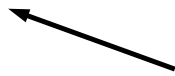
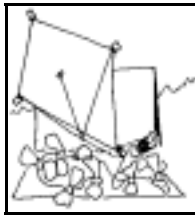

una cometa

una cama

un saco

un queso

un helado

una cuna

un coco

un equipo

un camión

un paquete

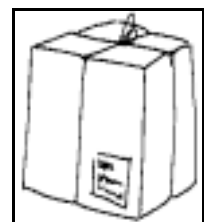
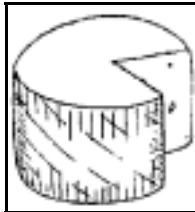
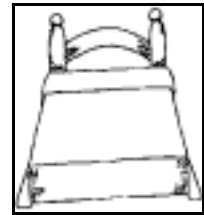



equipo



esquimal



casa



peccado

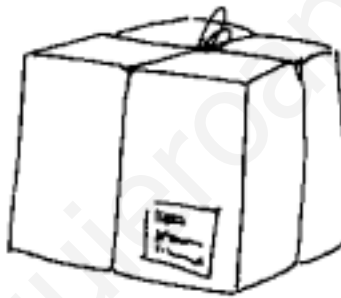

paquete

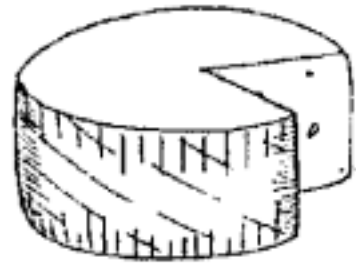

queso



químomo



campana



saco

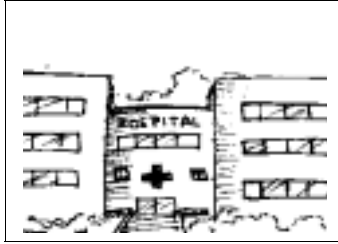

El médico sale del hospital



El estanque de los seis patitos

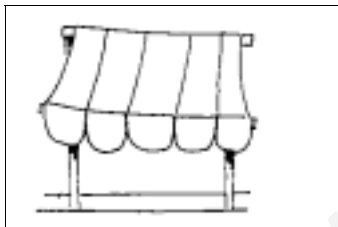

El toldo hace de quitasol



La casa del esquimal es de hielo



un - una

un diente

una pala

_____ copa

_____ cama

_____ camisa

_____ paquete

_____ pescado

_____ comida

_____ canoa

_____ quimono

_____ cuento

_____ escuela

_____ cohete

_____ quinqué

_____ máquina

_____ cuna

~~melocotones~~ ~~estanque~~ camisas médicos
 cacahuetes casas quesos quimonos esquina
 cuentos esquimal cocos máquina moqueta
 mantecas quitasol









ca-co-cu

melocotones

que-qui

estanque



 <p>Leo...</p>	<p>La casa del esquimal</p>	
		
<p>Nuy es un esquimal</p>	<p>Su casa es de hielo</p>	<p>Pasea en canoa</p>
		
<p>Come pescado</p>	<p>Seca el quimono</p>	<p>Enciende el quinqué</p>

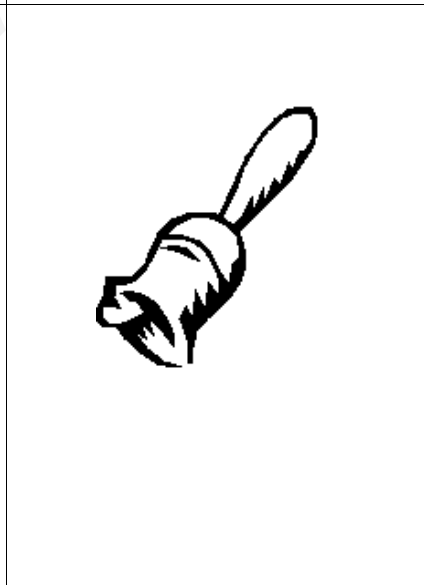
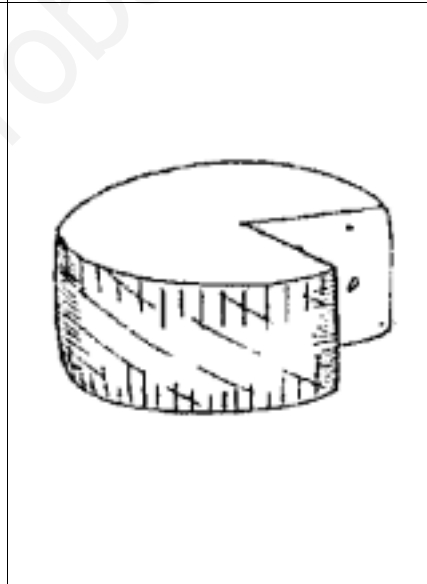
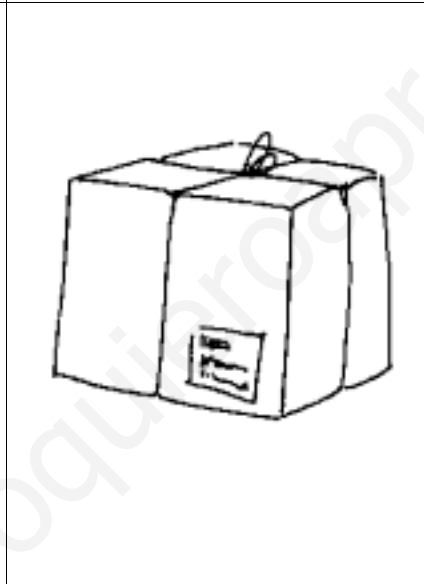
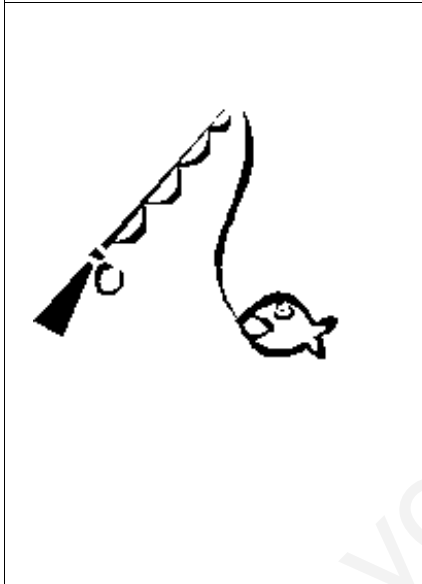



Nadia tiene una



.....

.....

Emi sale del



.....

.....



come pan con



.....

.....

La  es de Hu y de Sam

.....

.....

Ahmed cuida la



de su tío

.....

.....



La cama del esquimal.
El peso de mi tío Antonio.
Como queso, pan y tomate.
El paquete tiene una máquina.
La casa tiene seis esquinas.
La música sale de aquel paquete.
Mi camiseta tiene pintado un oso.
La meta de Luis tiene siete lados.



Handwriting practice lines with a watermark 'www.yoquieroaprobar.es'.



Tema 13

第十三课

Unit 13

La casa del esquimal.	爱斯基摩人的家	The skimo's house
Nuy es un esquimal.	努伊是个爱斯基摩人。	Nuy is an skimo
Su casa es de hielo.	他家是用冰做的。	His house is made of ice
Pasea en canoa.	乘独木舟散步。	He rides his canoa
Come pescado.	吃鱼。	He eats fish
Seca el quimono.	把和服晒干。	He dries his kimono
Enciende el quinqué.	把煤油灯点亮。	He lights the lamp



La cama del esquimal.	爱斯基摩人的床。	The skimo's bed
El pescado de mi tío Antonio	我叔叔安东尼奥的鱼。	Mi uncle Antonio's fish
Como queso, pan y tomate.	吃奶酪、面包和番茄。	I eat some cheese, bread and tomatoe
El paquete tiene una máquina.	包裹里有个机器。	The package has a machine
La casa tiene seis esquinas.	家里有六个角落。	The house has six corners
La música sale de aquel paquete.	音乐声从那个包裹里发出。	Music is coming out from that package
Mi camisa tiene pintado un oso.	我的汗衫上画了一个熊。	My shirt has a bear painted on it
La cometa de Luis tiene siete lados.	路易斯的风筝有七条边。	Luis' kittle has six sides



cha che chi cho chu ch Ch

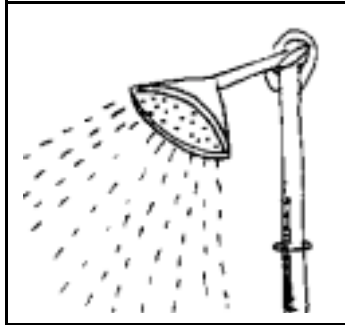

ducha

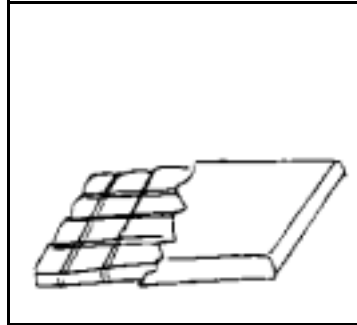

chocolate



Nacho



mochila



chaqueta



chupete



chinos

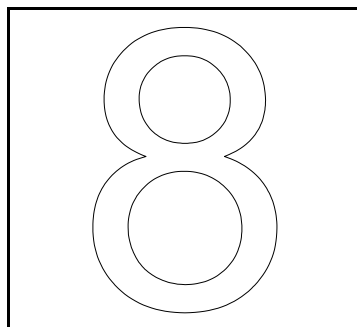

ocho

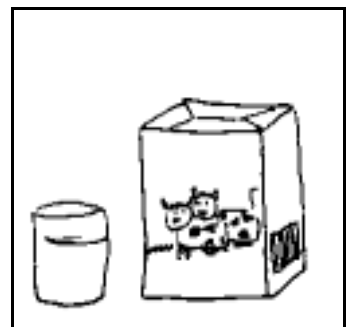

leche



ch Ch

cha che chi cho chu
Cha Che Chi Cho Chu

chino echo leche chaqueta
mochila chupete chocolate
ducha chupa Nacho chalé
poncho chica chimenea
ancho coche chico Chicho
mucho estuche mancha
chapa

La chaqueta de Chicho tiene
una mancha de chocolate

Nacho tiene un poncho muy
chico



Cha Che Chi Cho Chu

cha che chi cho chu

Ese coche es alto

Salen humos de la chimenea

El coche es cómodo

Los chinos comen helado

Nacho pone el chupete a Pepe

La chaqueta me queda ancha

Quique come nata y chocolate

¿Qué comes?



¿Qué comes?

Como pan con chocolate

¿Te queda ancha la camisa?

No, me queda chica

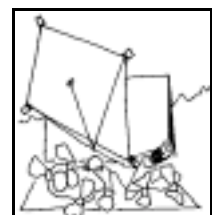
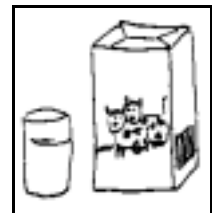
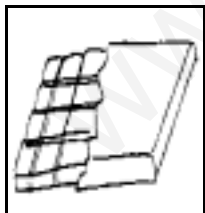
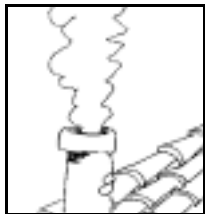
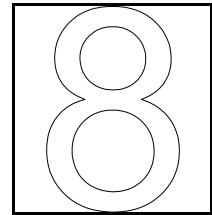

los chinos
 el ocho
 la chaqueta
 la leche
 la chimenea
 el chocolate
 la mochila
 el chupete
 Nacho
 la cometa

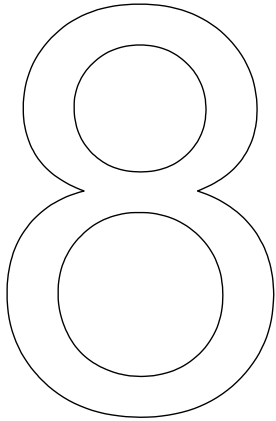

ocho



Nacho



leche

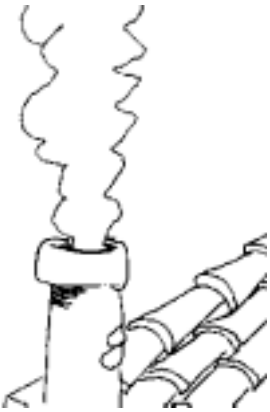

chimenea



coche



chocolate



mochila



chinos



chaqueta

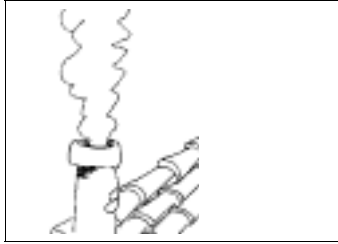

La chimenea de la casa es alta



La chaqueta de Sam es chica



El coche de papá echa humo

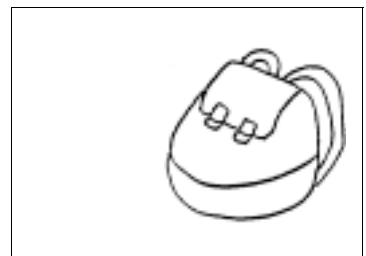

Nacho se pone la mochila



1 = un/a - dos = 2

dos	chinos	una	patata
_____	queso	_____	camas
_____	chupetes	_____	ducha
_____	ocho	_____	comidas
_____	coche	_____	coches
_____	chimenea	_____	escuela
_____	cohete	_____	mancha
_____	chino	_____	cuna



Se hace chico...



se hace chico...
casa - cas_ita
chino - chin_ito
mamá - mam_ita
mesa - mes_ita
Luisa - Luis_ita
pala - pal_ita
mono - mon_ito
esquina - esquini_ita

ito - ita
casita
chinito









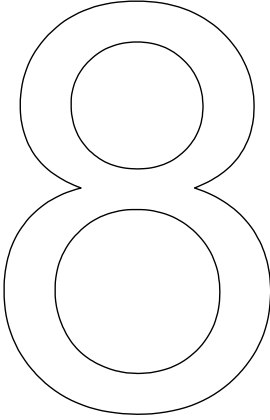

Lee...



<p>Le pasa a Nacho...</p>	<p>Nacho se ducha</p>	<p>Toma leche con chocolate</p>
<p>Se pone la chaqueta</p>	<p>Se pone la mochila</p>	<p>Se monta en el coche</p>
<p>¡Al cole, Nacho!</p>	<p>Nacho choca con Ana</p>	<p>¡Qué chichón, Nacho!</p>





La  echa humo

Nacho tiene una  de lana

 pone limpio el 

Pepe tiene un  de helado

Los  toman té caliente



El coche de papá es cómodo.
La chaqueta de Nacho es chica.
La chimenea de la casa es alta.
El humo sale de la chimenea.
Hua pone el chupete a Pepe.
Como pan y chocolate.
La leche está caliente.
Nacho limpia la mancha de la chaqueta.



Handwriting practice area with multiple sets of horizontal lines (solid top and bottom lines, dashed middle line) for writing practice.



Tema 14	第十四课	Unit 14
Le pasa a Nacho.	传给纳翘。	It happens to Nacho
Nacho se ducha.	纳翘淋浴。	Nacho showers
Toma leche con chocolate.	喝牛奶加巧克力。	He has some milk with chocolate
Se pone la chaqueta.	穿外套。	He puts his jacket on
Se pone la mochila.	背上书包。	He puts his bag on
Se monta en el coche.	坐上车。	He gets on the car
¡Al cole! Nacho!	去学校，纳翘！	Going to the school, Nacho!
Nacho choca con Ana.	纳翘撞了安娜。	Nacho encounters Ana
¡Qué chichón, Nacho!	好大个包啊，纳翘！	What a bruise, Nacho!
		
El coche de papá es cómodo.	爸爸的汽车很舒服。	Dad's car is very comfortable
La chaqueta de Nacho es chica.	纳翘的外套小了。	Nacho's jacket is too tight
La chimenea de la casa es alta.	房子的烟囱很高。	The house's chimney is high
El humo sale de la chimenea.	烟从烟囱里出来。	The smoke comes from the chimney
Hua pone el chupete a Pepe.	华给贝贝塞上奶嘴。	Hua gives the dummy to Pepe
Como pan y chocolate.	吃面包和巧克力。	I eat some bread and chocolate
La leche está caliente.	牛奶是热的。	The milk is hot
Nacho limpia la mancha de la chaqueta.	纳翘洗衣服上的污迹。	Nacho cleans the stain from the jacket



ga go gu

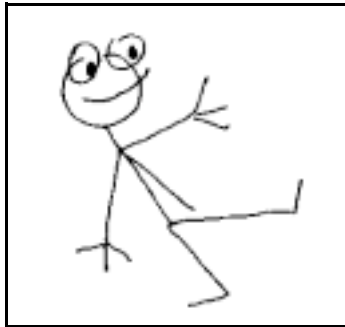
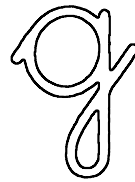

monigote

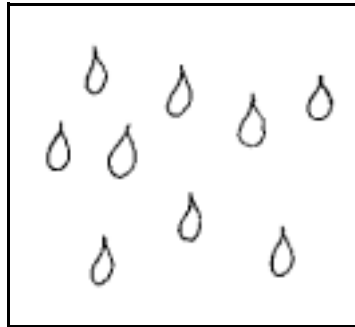

gotas



goma



gusano

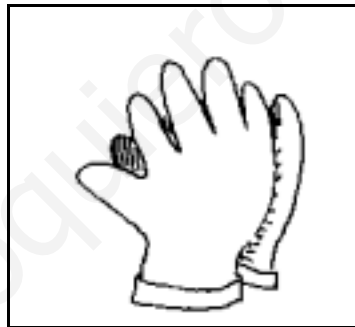

guantes

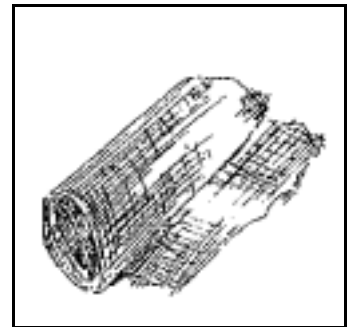

gasa



gato

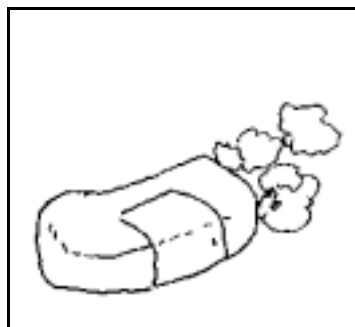

algodón

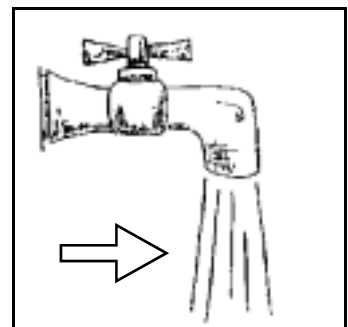

agua

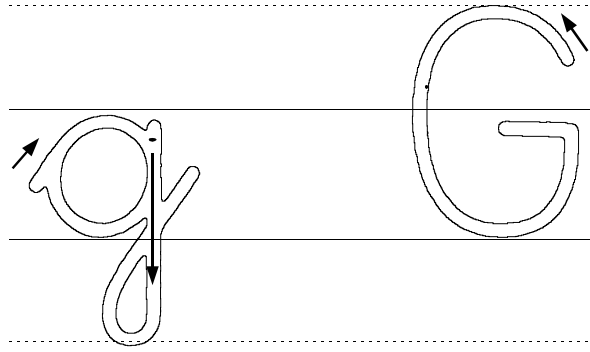

ga ge gu

Ga Ge Gu

monigote gato gusano lechuga
gota guantes algodón

Mamá usa guantes de goma.
El gato no usa guantes.
Diego seca a su gato y lo
mete en una palangana con
agua caliente.
El gato se asusta.
Salpica muchas gotas.
Luego lo seca.



Ga Ge Gu

ga ge gu

Pinto un monigote

Tengo en la mano una gasa

El gusano está en el agua

Tengo dos gomas y un papel

Limpio con algodón el dedo

Meto un gel a Diego

El gato no usa guantes

¡Qué guay!



¿Has metido un gol?

Si, y estoy muy content

¿Tomas agua?

No, tomo leche

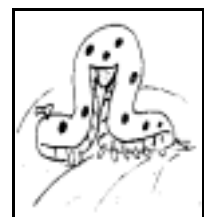
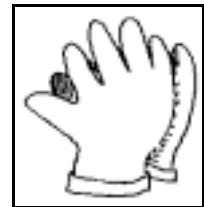
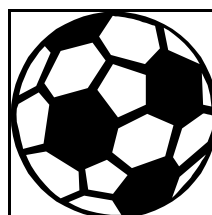
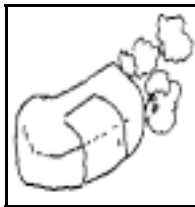
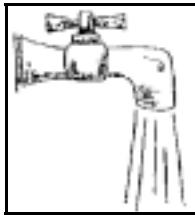

el agua
 las gotas
 los guantes
 la leche
 el algodón
 el gusano
 la gasa
 el gato
 la goma
 la pelota





mimicote



gato



gotas



quasame



guantes

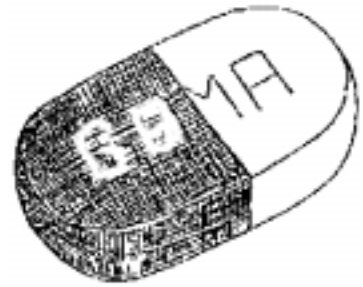

gema

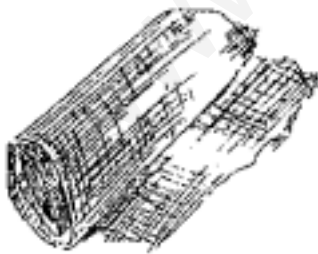

gasa



algodón

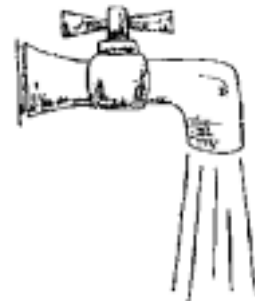

agua

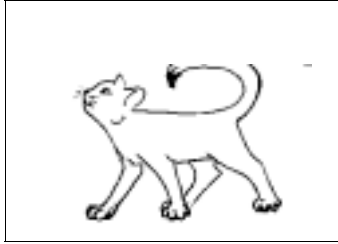

Diego asea a su gato

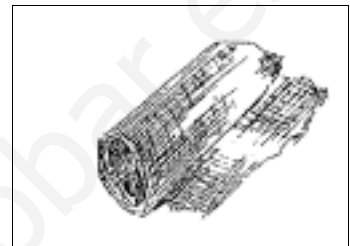

El médico le pone gasa en el dedo

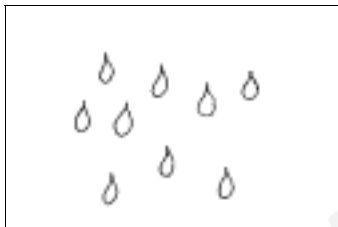

Gotas de agua caen en el coche



Diego mete un gol



el - la

el paquete
 _____ algodón
 _____ gata
 _____ monigote
 _____ guante
 _____ pomada
 _____ camión
 _____ coche

la gasa
 _____ médico
 _____ gol
 _____ gato
 _____ gota
 _____ esquimal
 _____ mancha
 _____ agua

~~esquina~~ quentes gasa esquimal
 queso algodón quimono monigote
 agua paquete

G

Q
esquina



 <p>Leo...</p>	<p>¡Gol!</p>	
		
<p>Luis ¿Tienes la pelota?</p>	<p>Sí, Lola, aquí está</p>	<p>Pásamela, Nacho</p>
		
<p>Toma, Adela</p>	<p>¡Cuidado, Quique!</p>	<p>¡Gol!</p>

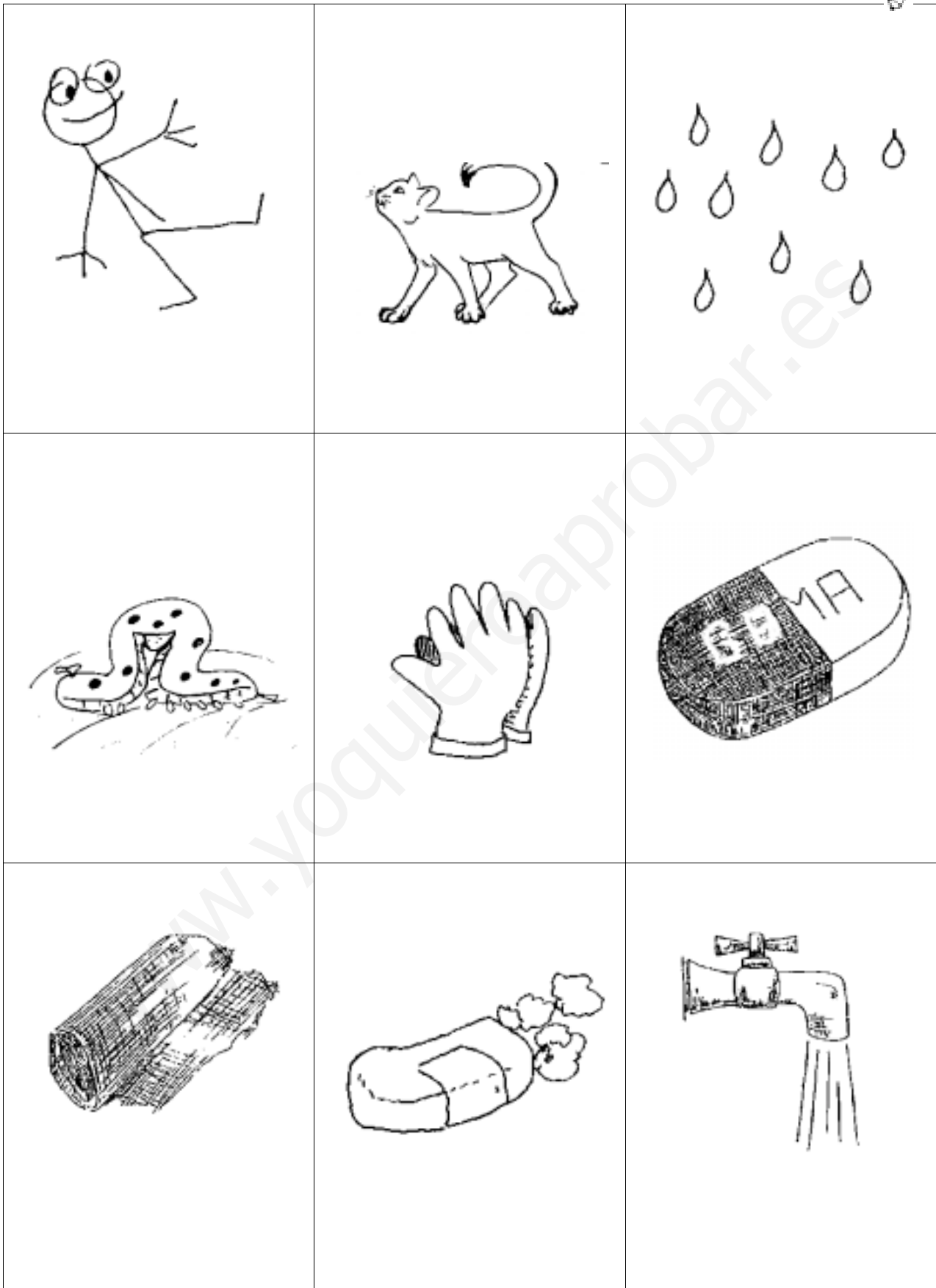



El  se asusta

.....

.....

Usa unos  de goma

.....

.....

 limpia el  con agua

.....

.....

El médico pone  en el dedo

.....

.....

Pinto un  y uso la goma

.....

.....



Diego asea al gato.
Lo mete en una palangana.
La palangana tiene agua caliente.
Usa unos guantes de goma.
El gato se asusta.
Salpica muchas gotas de agua.
Se pone al sol.
Luego se seca.



Handwriting practice area with multiple sets of horizontal lines (top, middle, bottom) and a dotted midline. Two small circles are placed at the beginning of the first two lines.



Tema 15	第十五课	Unit15
¡Gol!	进球！	Goal!
Luis, ¿Tienes la pelota?	路易斯，你控制球了吗？	Luis, are you holding the ball?
Sí, Lola, aquí está.	是的，劳拉，球在这里。	Yes, Lola, here it is
Pásamela. Nacho.	传给我，纳翘。	Pass it to me, Nacho!
Toma, Adela.	接着，阿黛拉。	Here you are, Adela
¡Cuidado, Quique! ¡Gol!	小心，奇盖！进球！	Look out, Quique! Goal!
Diego asea al gato.	迪耶哥给猫洗澡。	Diego is cleaning the cat
Lo mete en una palangana	把猫放进脸盆。	He is putting it in a washbasin
La palangana tiene agua caliente.	脸盆里的水很烫。	The washbasin is containing some hot water
Usa unos guantes de goma.	他戴着橡皮手套。	He uses rubber gloves
El gato se asusta.	猫很害怕。	The cat has got frightened
Salpica muchas gotas de agua.	把水都溅出来了。	It is spilling a lot of water
Se pone al sol.	晒太阳。	It is staying under the sun
Luego se seca.	后来就干了。	Then it dries



ga que qui go qu

que Qui



Miguel



Águeda

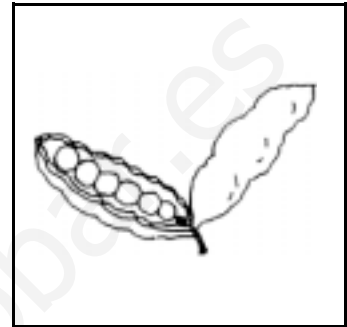

guisantes

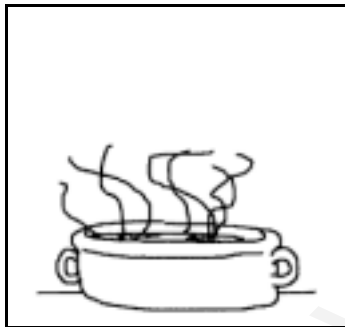

guiso

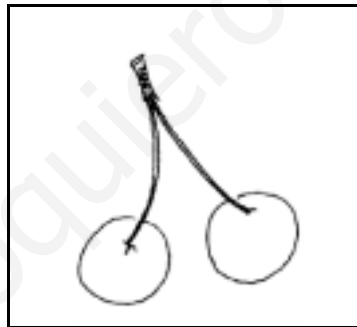

quindas



águila

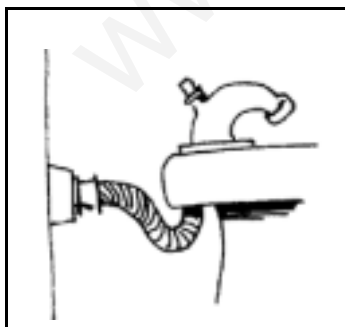

manquito



espagueti

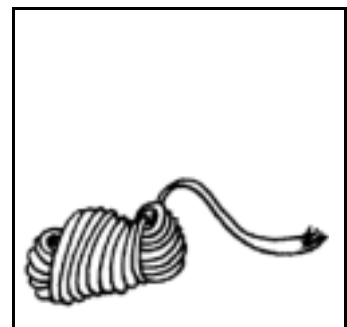

quita



que Qui

qa que qui qo qu
Ga Gue Gui Go Gu

quisano qeta quantes lechuga
qema algodón quisantes quise
qolesina quindas anguila
áquila aguilicho Miguel
Áqueda qamo lazo quisado
manguito quita amigo manga
qol qanco migas aqua maço
qanche

Miguel come quisantes con
aceite y sal.

Áqueda pinta un áquila.



Ga Gue Gui Ge Gu

ga gue gui ge gu

Meto un gol

Como golosinas

El águila come un gusano

Mi amigo toma agua

La chaqueta tiene dos mangas

El mago saca palomas

La anguila nada en el lago

Como lechuga y quisantes



¿Has comido guisantes?

No, he comido quindas

¿Tomas golosinas?

Sí, y me gustan mucho

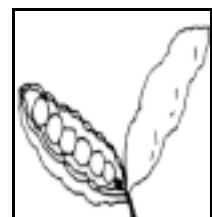
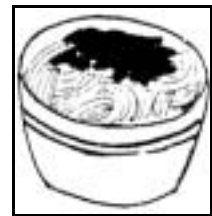
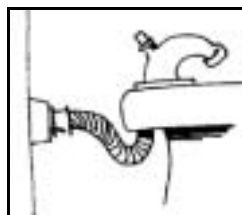
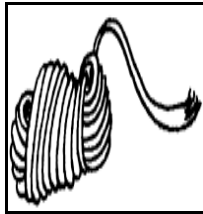

el guiso
 la águila
 Miguel
 la quita
 los guisantes
 las quindas
 el espagueti
 Águeda
 el nido
 el manguito

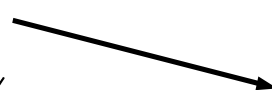



Águeda



quindas



quisantes



águila

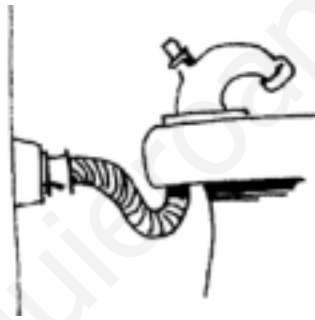

manguito



quita



quiso



Miguel



espagueti



Miguel come guisantes

.....



Diego pinta un monigote

.....



Hua y Águeda son amigas

.....



Me gustan los espaguetis con queso

.....



~~ga~~ ga go go qui ga go qu qu

Dame el algodón

Se acosta del a__a

Luisa tiene un __to

Salpicó __tas de a__a

El á__la tiene un nido

El __sano come lechu__

Die__ pinta un meni__to

~~algodón~~ quita anguila agua
manguito gol monigote Miguel
amiga quindas

ga go qu

algodón

que qui



 <p>Leo...</p>	<p>Mamá águila</p>	
		
<p>Ésta es mamá águila</p>	<p>Tiene un nido</p>	<p>El nido tiene un aguilucho</p>
		
<p>Mamá águila le da la comida</p>	<p>El aguilucho come</p>	<p>El aguilucho sigue a su mamá</p>

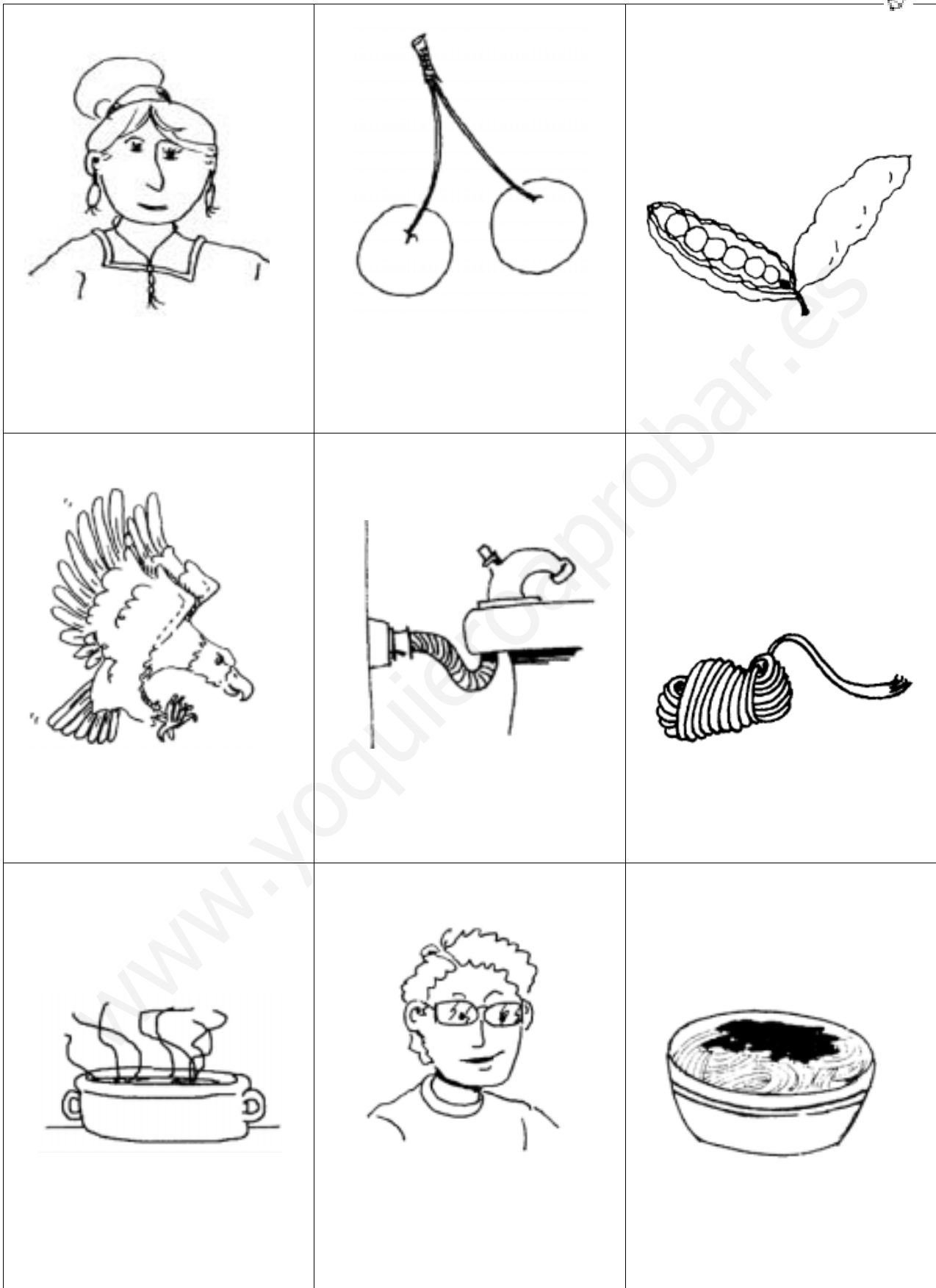



come guisantes

.....

Toma



caliente

.....

En aquel



está el águila

.....

El médico sana a



.....

Este



tiene guisantes y sal

.....



El agua pasa el puente.
La chaqueta tiene dos mangas.
El guiso está caliente.
Como guisantes con sal.
Me gustan los espaguetis con tomate.
Águeda pinta un águila.
La anguila nada en el lago.
Me gustan las golosinas.



Handwriting practice lines with a watermark: www.yoquieroaprobar.es



Tema 16	第十六课。	Unit 16
Mamá águila.	鹰妈妈。	Mother eagle
Ésta es mamá águila.	这是鹰妈妈。	This is mother eagle
Tiene un nido.	它有一个窝。	She has a nest
El nido tiene un aguilucho.	窝里有一个小鹰。	There is an eaglet in the nest
Mamá águila le da la comida.	鹰妈妈 给 它 喂食。	Mother eagle feeds him
El aguilucho come.	小鹰吃。	The eaglet is eating
El aguilucho sigue a su mamá.	小鹰 跟着 它的妈妈。	The eaglet follows his mother



El agua pasa el puente.	水从桥下流过。	The water goes under the bridge
La chaqueta tiene dos mangas.	外套有两个袖子。	The jacket has two sleeves
El guiso está caliente.	菜是热的。	The stew is hot
Como guisantes con sal.	我吃豌豆加盐。	I am eating some peas with salt
Me gustan los espaguetis con tomate.	我喜欢吃意大利面加番茄。	I like spaghetti with tomato sauce
Águeda pinta un águila.	阿给达画一只老鹰。	Águeda is painting an eagle
La anguila nada en el lago.	鳗鲤在湖里游泳。	The eel is swimming in the lake
Me gustan las golosinas.	我喜欢糖果。	I like candy



fa fe fi fo fu
af ef if of uf

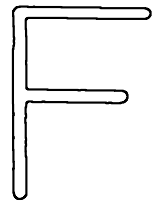

familia



fantasma

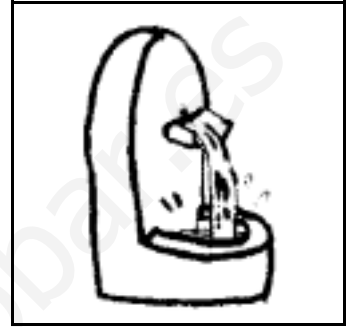

fuenta

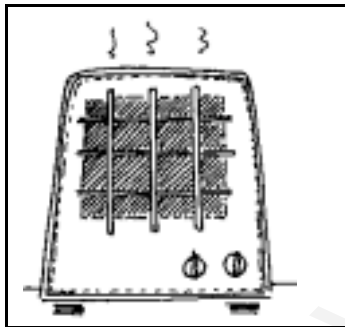

estufa



teléfono

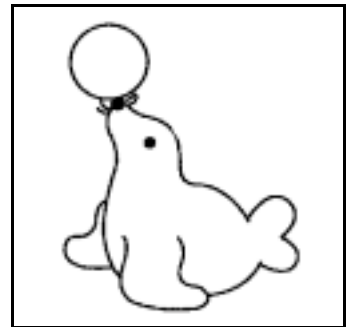

foca



fideos

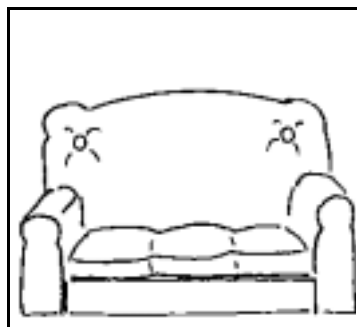

sofá



café

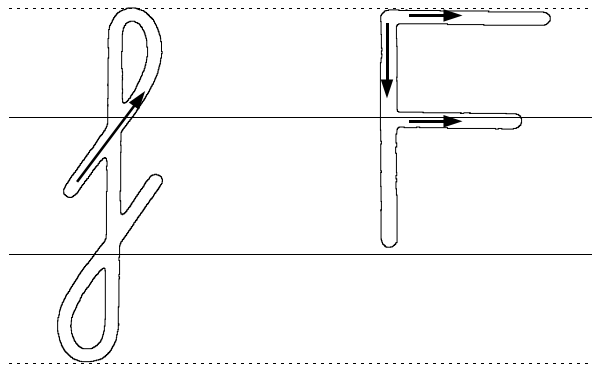

fa fe fi fo fu
Fa Fe Fi Fo Fu

foto elefante teléfono fideos fila
familia estufa foca café fuente
fantasma falda gafas Fátima
sofá moqueta fino Faustina

El fantasma da miedo.
Fátima tiene una falda.
La estufa está caliente.
Las gafas de Miguel.
La foca Faustina.
La familia de indios.
La foto de la foca Faustina.



Fa Fe Fi Fo Fu

fa fe fi fo fu

La fuente tiene agua

El fantasma da miedo

Miguel tiene gafas

Fátima se pone la falda

La familia de focas

El café está caliente

Como fideos con tomate

No me gusta la foto del sofá



¿Te gusta el sofá?

Sí, es muy cómodo

¿Comes fideos?

No, como espaguetis con tomate

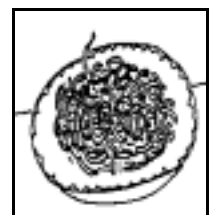
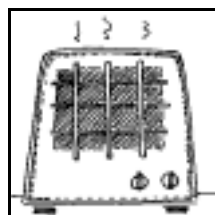
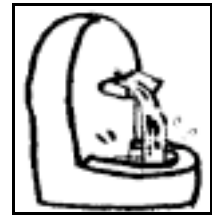

la fuente
 el café
 el fantasma
 la familia
 el elefante
 la foca
 el teléfono
 los fideos
 la estufa
 el fuego



fuentes



café



fantasma



elefante



foca



teléfono



familia

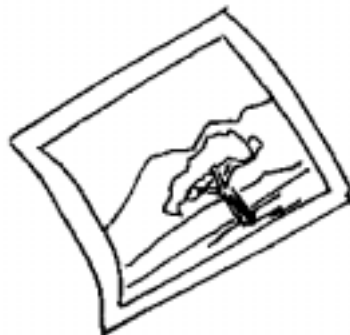

foto

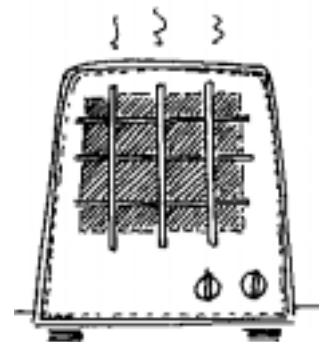

estufa



Miguel usa gafas finas



Fátima se pone la falda

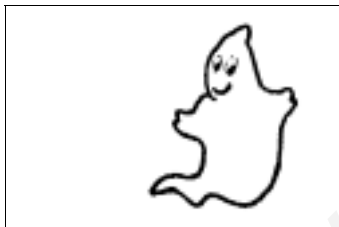

Este fantasma da poco miedo

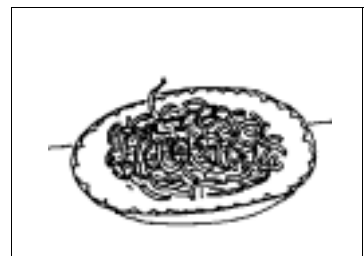

Me gustan los fideos con tomate



¿Quién se sienta en el sofá?

Fátima

~~El café~~

Miquel

Lulú

La estufa

Hua

Alí

Un camión

Lola

Diego

El paquete

La cometa

Pepe

El teléfono

Quique

El monigote



~~fideos~~ chaqueta pelota focas foto
teléfonos falda pelotas amigos
fantasma

muchos-as
fideos

uno-a



 <p>Leo...</p>	<p>La foca Faustina</p>	
		
<p>Ésta es la foca Faustina</p>	<p>Es muy chica</p>	<p>Ésta es su familia</p>
		
<p>Come sopa con fideos</p>	<p>Salta en la fuente</p>	<p>Se hace una foto</p>

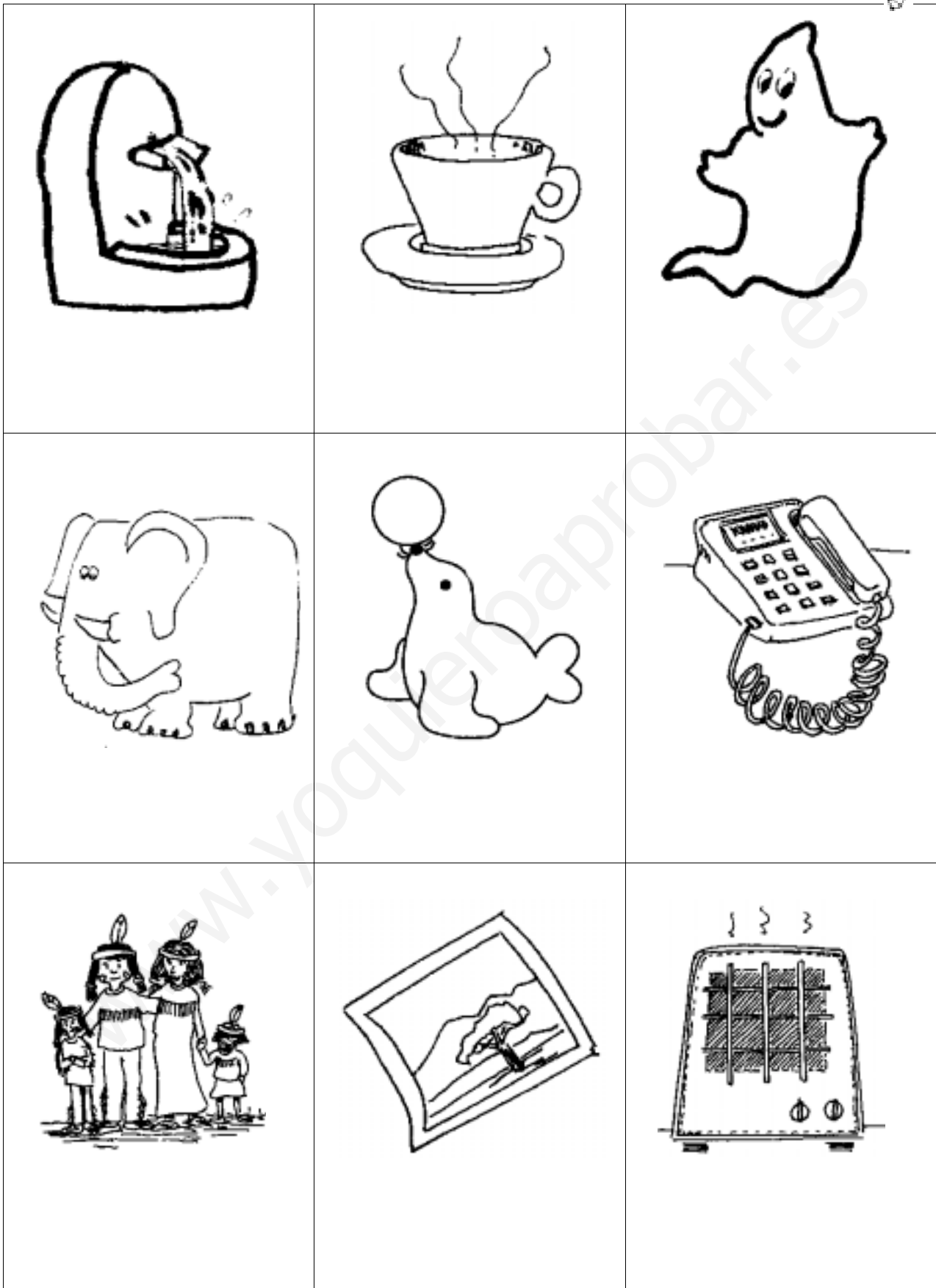



usa gafas chicas



Toma caliente con leche

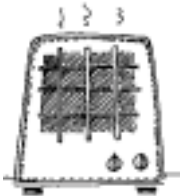

La calienta la casa

La foto de la  de Fátima



Este tiene dientes



El fantasma da miedo.
Fátima tiene una falda.
La estufa está caliente.
Las gafas de Miguel son chicas.
El café con leche está muy caliente.
La familia de indios.
La foto de la foca Faustina.
Como fideos con tomate y mucha sal.



Handwriting practice lines with a watermark: www.yoquieroaprobar.es



Tema 17	第十七课	Unit 17
La foca Faustina.	海豹法斯蒂娜。	Faustina the seal
Ésta es la foca Faustina.	这是海豹法斯蒂娜。	This is Faustina the seal
Es muy chica.	它很小。	She is very little
Ésta es su familia.	这是它的家庭。	This is her family
Come sopa con fideos.	它喝面条汤。	She is eating some niddle soup
Salta en la fuente.	它在水池里跳。	She is jumping around the fountain
Se hace una foto.	它拍照。	She is having her photo taken



El fantasma da miedo.	幽灵很可怕。	The ghost is scaring
Fátima tiene una falda.	法体玛有条裙子。	Fátima has a skirt
La estufa está caliente.	暖气很热。	The stove is hot
Las gafas de Miguel son chicas.	米盖尔的眼镜很小。	Miguel's glasses are small
El café con leche está muy caliente.	牛奶咖啡很烫。	This cup of white coffee is very hot
La familia de indios.	印第安人的家庭。	The Indian family
La foto de la foca Faustina.	海豹法斯蒂娜的照片。	Faustina the seal's photo
Como fideos con tomate y mucha sal.	我吃加很多盐的番茄面条。	I am eating some noddles with tomato sauce and a lot of salt



ra re ri ro ru

ar er ir or ur

r R

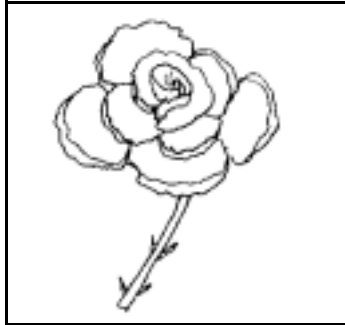

rosa



ruso



rio

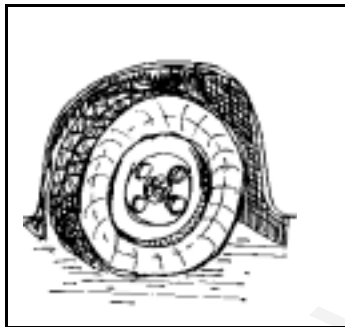

rueda



raqueta

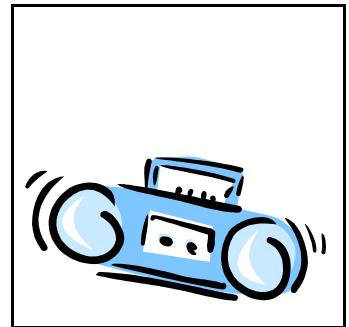

radio

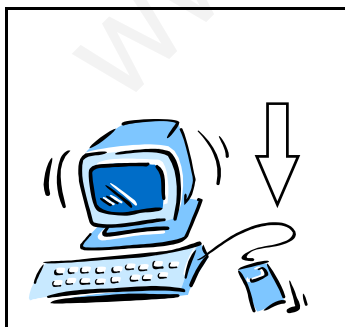

ratón

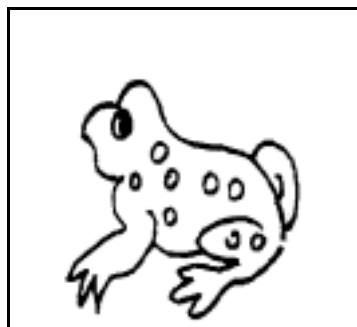

rana



ropa

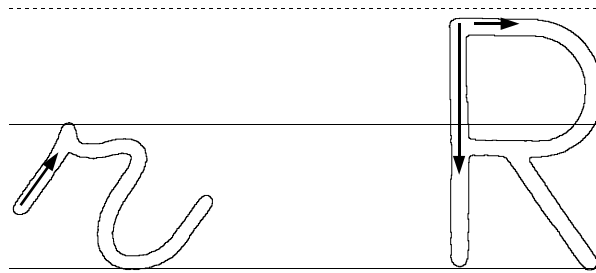

ra re ri ro ru
Ra Re Ri Ro Ru

ratón rosa radio rasca rama
raqueta ramo río reto rey
parque tarde risa ruso charco
Ramón ruido Raquel ropa
arcón Rita arca Rafael raso

Lulú muerde la ropa.
Raquel tiene un ramo.
Rafael pincha la pelota.
Miguel come remolacha.
La rama salta al río.
El ruso se calienta en casa.



Ra Re Ri Re Ru

ra re ri re ru

or en in en un

La rosa tiene espinas

Miguel da un ramo a Raquel

Rafael pasea por el parque

Lulú muerde la ropa de Hua

Alí se mete en el charco

Como remolachas con sal

Guardo la ropa en el arcón



Ten cuidado.

Si das muy fuerte en el suelo

puedes romper la raqueta.

Si, tengo mucho cuidado.



la rueda

la radio

la rosa

el ratón

el ramo

la rana

el río

la raqueta

el rey

la reina

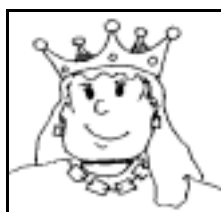
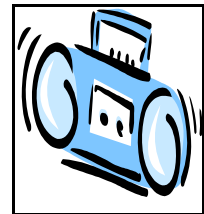

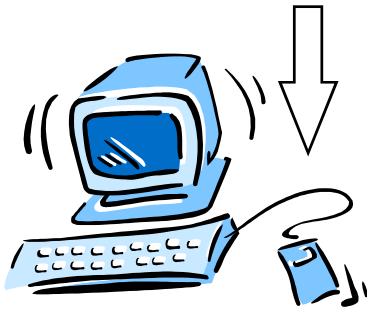

ratón



rana



Raquel



ramo

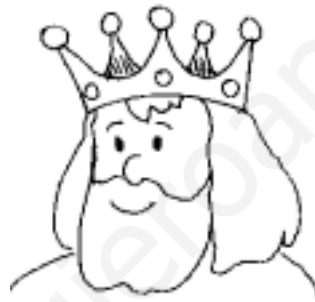

rey



reina



remolacha



rote



ropa

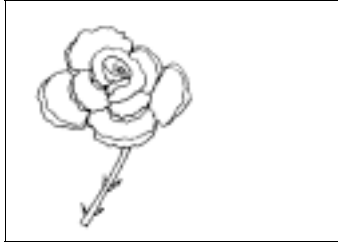

La rosa tiene espinas

.....



Lulú quiere morder la ropa

.....



Raquel guarda su ropa

.....

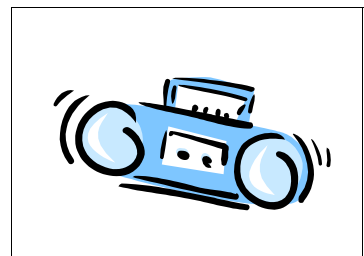

Rafael escucha la radio

.....



Hago un ramo de...

Rosas

~~ruidos~~

Lilas

Tomates

Pantalones

Tulipanes

Dalias

Amapolas



~~ratón~~ tarde dardo río parque
rama rosa arca remo charco







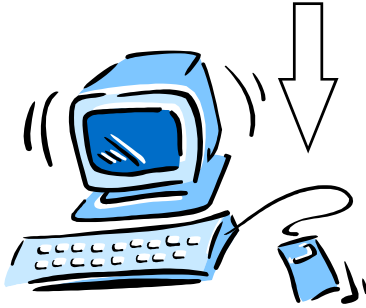

ra-re-ri-ro-ru
ratón

ar-er-ir-or-ur



 <p>Leo...</p>	<p>La ratita Rita</p>	
		
<p>Ésta es la ratita Rita</p>	<p>Es muy coqueta</p>	<p>Tiene una moneda</p>
		
<p>Se pone una diadema rosa</p>	<p>El ratón Roque pasa por su casa</p>	<p>¿Nos casamos ratita? Sí, sí</p>





Miguel da un ramo a



Lulú muerde la



de Rita

Rafael se pincha con la



La



salta en el charco

Ramón escucha la





Lulú muerde la ropa.
Raquel tiene un ramo de rosas.
Rafael pincha la pelota.
Miguel come remolacha con mucha sal.
La rana salta al río.
El ruso se calienta en la estufa.
Asia tiene dos raquetas de tenis.
El rey y la reina pasean por el río.



Handwriting practice lines with a watermark: www.yoquieroaprobar.es



Tema 18	第十八课	Unit 18
La ratita Rita	小老鼠丽塔。	Rita the little rat
Ésta es la ratita Rita.	这是小老鼠丽塔。	This is Rita the little rat
Es muy coqueta.	她非常喜欢卖弄风情。	She is very vain
Tiene una moneda.	她有一个硬币。	She has a coin
Se pone una diadema rosa.	她带上一条粉红色的发带。	She is putting a pink hair-band on
El ratón Roque pasa por su casa.	小老鼠罗克从她家过。	Roque the mouse has come by her house
¿Nos casamos ratita? Sí, sí.	小老鼠我们结婚好吗? 好,	Will you marry me, little rat? Yes, yes.
		
Lulú muerde la ropa.	露露咬着衣服。	Lulú is biting the clothes
Raquel tiene un ramo de rosas.	拉卡尔有一束玫瑰花。	Raquel has a bunch of roses
Rafael pincha la pelota.	拉法尔刺着球。	Rafael has bursted the ball
Miguel come remolacha con mucha sal.	米盖尔吃糖萝卜加很多盐。	Miguel is eating some beetroot wit a lot of salt
La rana salta al río.	青蛙跳到河里。	The frog is jumping into the river
El ruso se calienta en la estufa.	那位俄国人用暖气取暖。	The Russian is warming up by the stove
Asia tiene dos raquetas de tenis.	阿西亚有两个网球拍。	Asia has two tennis rackets
El rey y la reina pasean por el río.	皇上和皇后在河边漫步。	The king and the queen are walking by the river



ara ere iri oro uru
arra erre irri orro urru

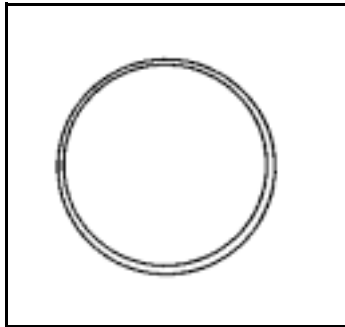
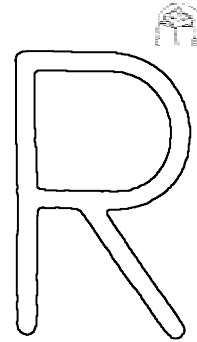

aro



perro

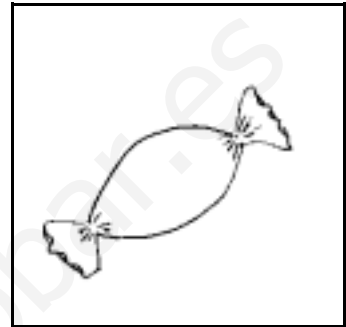

caramelo

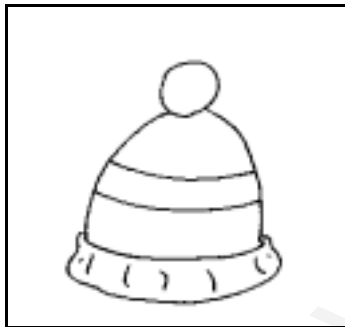

gorro

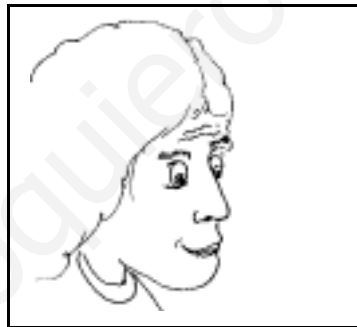

cara

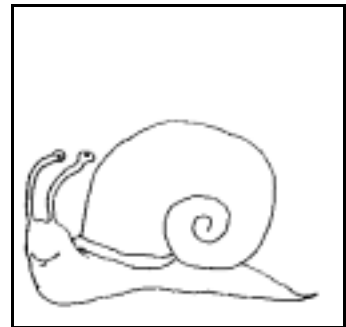

caracol



paraguas



pera

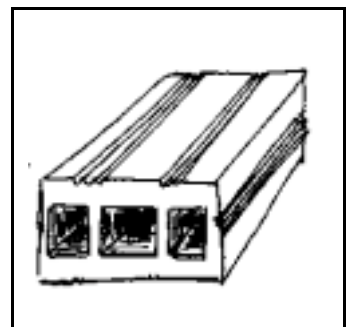

duro



ara ere iri oro uru
arra erre irri orro urru

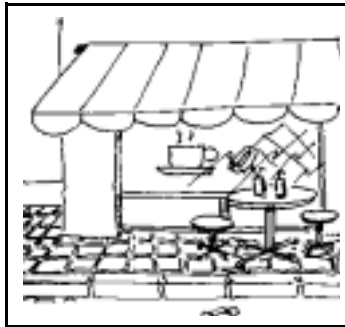
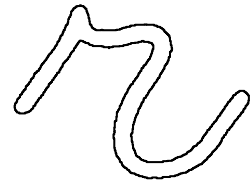

cafetería

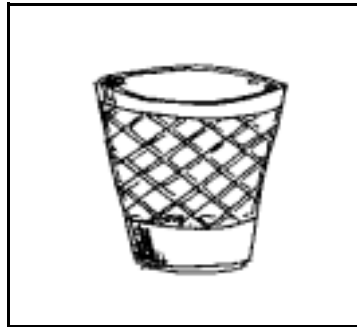

papelera



pirata

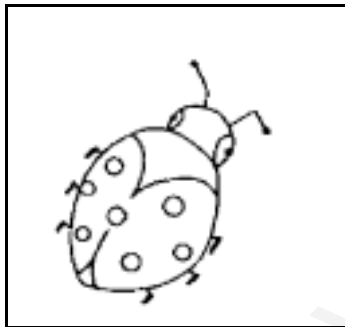

mariposa

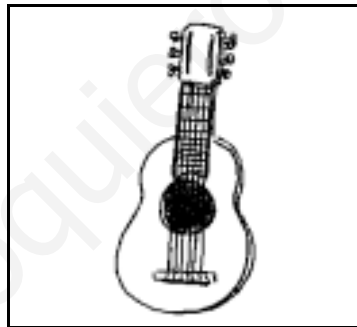

guitarra

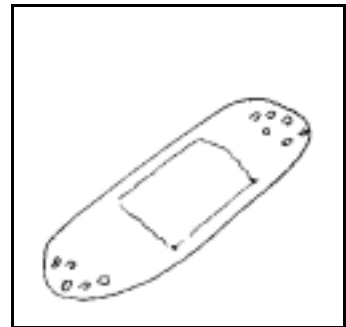

tirita



salero

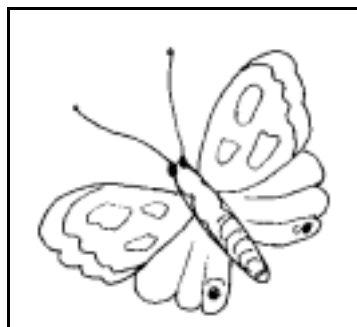

mariposa

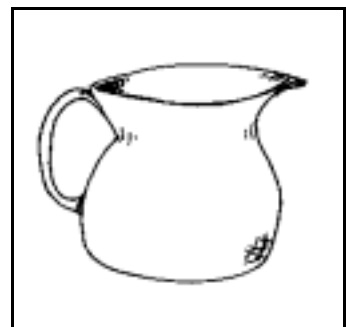

lechera

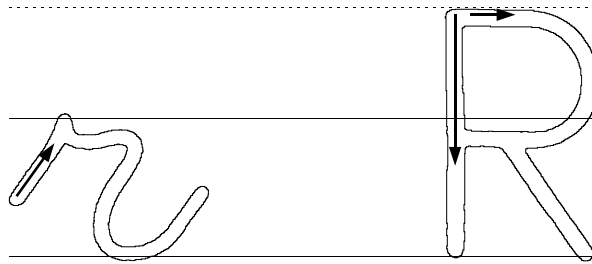

ara ere eri ero uru

arra erre irri erre urra

aro oro era hora lero

mariposa caracol sardina

tortuga lagarto loro ferro

papelera pera perro dinero

sepera fero pirata puro tarro

parra Carro Marta gerro

El perro pisa el charco

Carro tiene un caracol

Marta come peras con miel

La parra está seca

El ferro del gerro es resaca



ara ere iri ere uru

arra erre erri erre erru

ore era ir ere hera ira

La pera tiene hojas

La mariposa tiene colores

El caracol camina despacio

La isla del pirata tiene faro

Mima se pone la gorra

Entro en la cafetería

Me pongo una tirita en el dedo



Miguel come peras

¿Qué come Miguel?

Marta tiene una falda rosa

¿Qué tiene Marta?

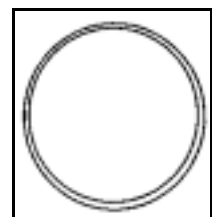
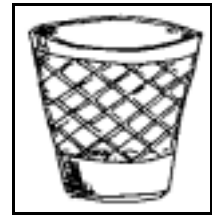
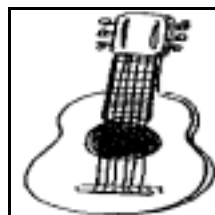

la papelerera
 la pera
 la mariposa
 la tirita
 el perro
 el caracol
 el aro
 el pirata
 la guitarra
 la lechera

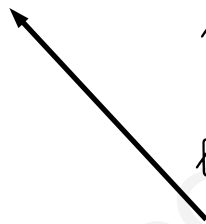



gorro



paraguas



salero



tiritita



pera



guitarra



torre



caramelo



perro

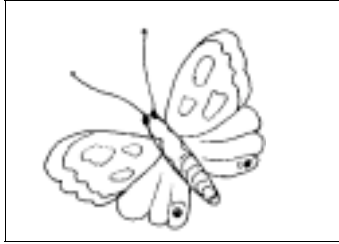

La mariposa María

.....



La pata de palo del pirata

.....

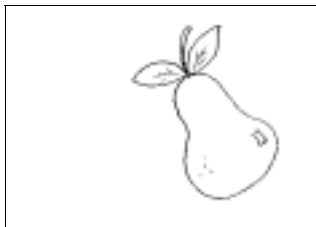

Raquel come peras con miel

.....



Me pongo una tirita en el dedo

.....



Animales...

Perro

~~Tesoro~~

Sardina

Loro

Tarro

Pato

Toro

Faro

Mariposa

Elefante

Sopera

Gato

Ratón

Isla

Barco

Foca



<p>aro tarro oro loro perro faro tierra turrón mariposa Curro</p>
--

-r-
aro

-rr-











 <p>Leo...</p>	<p>La mariposa Maria</p>	
		
<p>Tiene muchos colores en sus alas</p>	<p>Tiene dos antenas</p>	<p>Es amiga de las rosas</p>
		
<p>Es amiga del caracol</p>	<p>Es amiga de un gusano</p>	<p>Cuando sale el sol, pasea</p>



 <p>Leo...</p>	<p>El pirata Malapata</p>	
		
<p>Malapata es un pirata</p>	<p>Tiene una pata de palo</p>	<p>Su cara es muy fea</p>
		
<p>Esta isla es de él</p>	<p>Tiene un arca con mucho oro</p>	<p>y un tesoro escondido.</p>





María es una  simpática

Malapata tiene una 

Rafael se pincha con la 

Se pone una  en el dedo

Mina pide leche en la 



Este es Fufú, el elefante.
 Fufú está muy enfadado.
 La elefanta Rufina le pide
 comida.
 Fufú se la da.
 Fufú y Rufina salen de fiesta



Completa

Este es Fufú, el _____ .

Fufú está muy _____ .

La elefanta Rufina le pide _____ .

Fufú y Rufina salen de _____ .



Completa

Uno 

Muchos 

el elefante _____

la fiesta _____

el fantasma _____



Ordena

fantasma tiene El foto. una



Tema 19	第十九课	Unit 19
La mariposa María.	蝴蝶玛丽亚。	Maria the butterfly
Tiene muchos colores en sus alas.	她翅膀上有许多颜色。	Her wings have a lot of colours
Tiene dos antenas.	还有两个触角。	She has two antennas
Es amiga de las rosas.	她是玫瑰花的朋友。	She is a friend of the roses
Es amiga del caracol.	是蜗牛的朋友。	She is a friend of the snail
Es amiga de un gusano.	也是一个虫子的朋友。	She is a friend of a worm
Cuando sale el sol, pasea.	太阳出来的时候，她就去散	When the sun rises, she goes for a walk



El pirata Malapata.	独脚海盗。	Malapata the pirate
Malapata es un pirata.	独脚是一个海盗。	Malapata is a pirate
Tiene una pata de palo.	他有一只木脚。	He has a wooden leg
Su cara es muy fea.	他的脸很难看。	He has such an ugly face
Esta isla es de él.	这个小岛是他的。	This island is his
Tiene un arca con mucho oro.	他有一个木箱里面有许多金	He owns a chest full of gold
Y un tesoro escondido.	还藏着一个宝藏。	He owns a hidden treasure, too
Este es Fufú, el elefante.	这是大象福福。	This is Fufú the elephant
Fufú está muy enfadado.	福福他很生气。	Fufú is very angry
La elefanta Rufina le pide comida.	大象卢飞娜向福福要吃的。	Rufina the elephant ask him for some food
Fufú se la da.	福福给她了。	Fufú gives it to her
Fufú y Rufina salen de fiesta.	福福和卢飞娜一起出去玩。	Fufú and Rufina go partying.



ja je ji jo ju
aj ej ij oj uj

j

J



juguetes



conejo

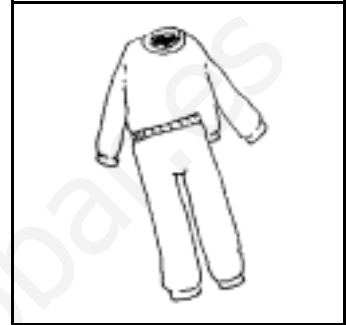

pijama

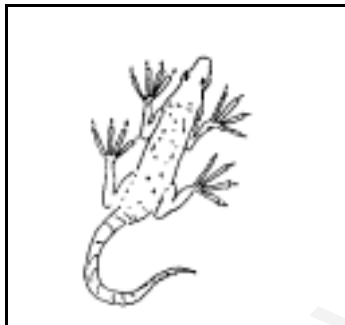

lagartija

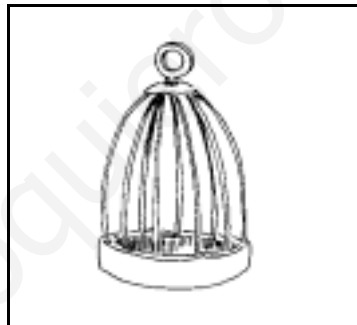

jaula

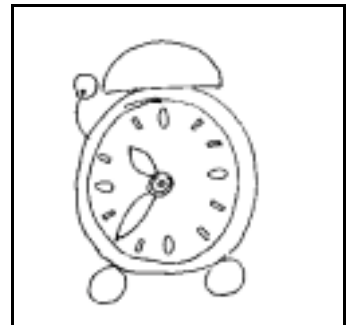

reloj

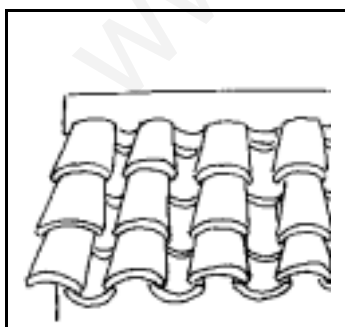

tejado

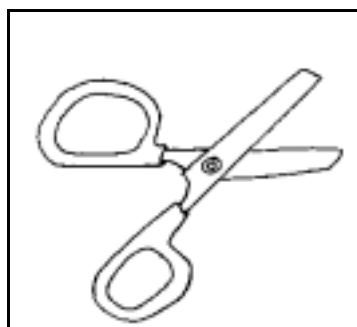

tijeras

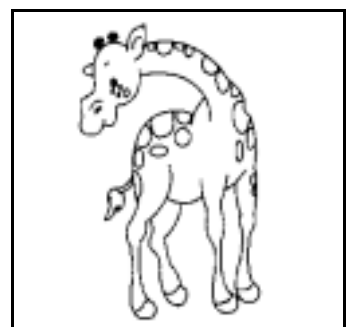

jirafa

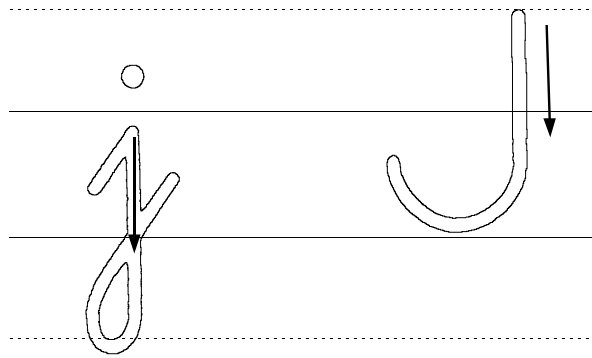

ja je ji jo ju

Ja Je Ji Jo Ju

juguete conejo pijama jaula
lagartija Jaime tejado tijeras
jirafa naranjas Juan jersey
aguja Jesús caja pájaros hoja
jola paja.

La jirafa come hojas.

Los pájaros y las lagartijas se
acostan.

Cuando el reloj da las ocho,
dejo de jugar con mis juguetes
y me pongo el pijama.



Ja Je Ji Jo Ju

ja je ji jo ju

aj ej ij oj uj

La jirafa come hojas

El reloj de Jaime es rojo

El pájaro sale del nido

A las ocho me pongo el pijama

Curro tiene un jersey marrón

El conejo se mete en la jaula

Como naranjas de postre



En la jaula hay dos pájaros.

¿Cuántos pájaros hay en la jaula?

Marina tiene un pijama rosa.

¿Qué tiene Marina?

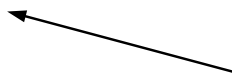
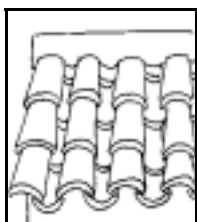

la jaula
 la jirafa
 el pijama
 la caja
 el tejado
 el jersey
 la reja
 las tijeras
 la naranja
 la aguja

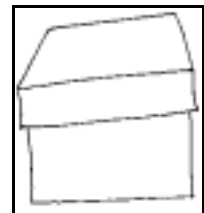



Jaime

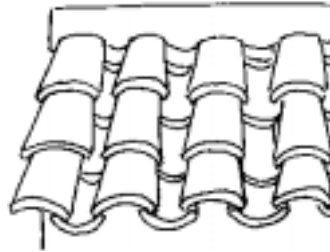

tejado



tijeras



girafa



naranja



jersey



aguja

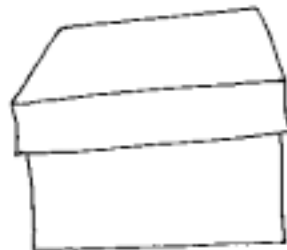

caja



reja

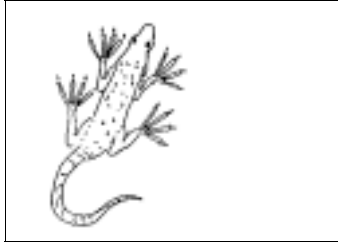

La lagartija se asusta, tiene miedo



El perro muerde el pijama



La jirafa come hojas



Jaime juega con sus juguetes



En la cara...



~~ojo~~ ~~agua~~ jaula rojo jarra tejado
 Jaime dedo jefe Juan aguja jersey

-j-
ojo

-j-



 <p>Leo...</p>	<p>La jirafa Garrafa</p>	
		
<p>Ésta es la jirafa Garrafa</p>	<p>Es de color naranja y marrón</p>	<p>Es muy alta</p>
		
<p>Más alta que el tejado</p>	<p>Come muchas hojas</p>	<p>¡Cuidado! que te comes una lagartija</p>

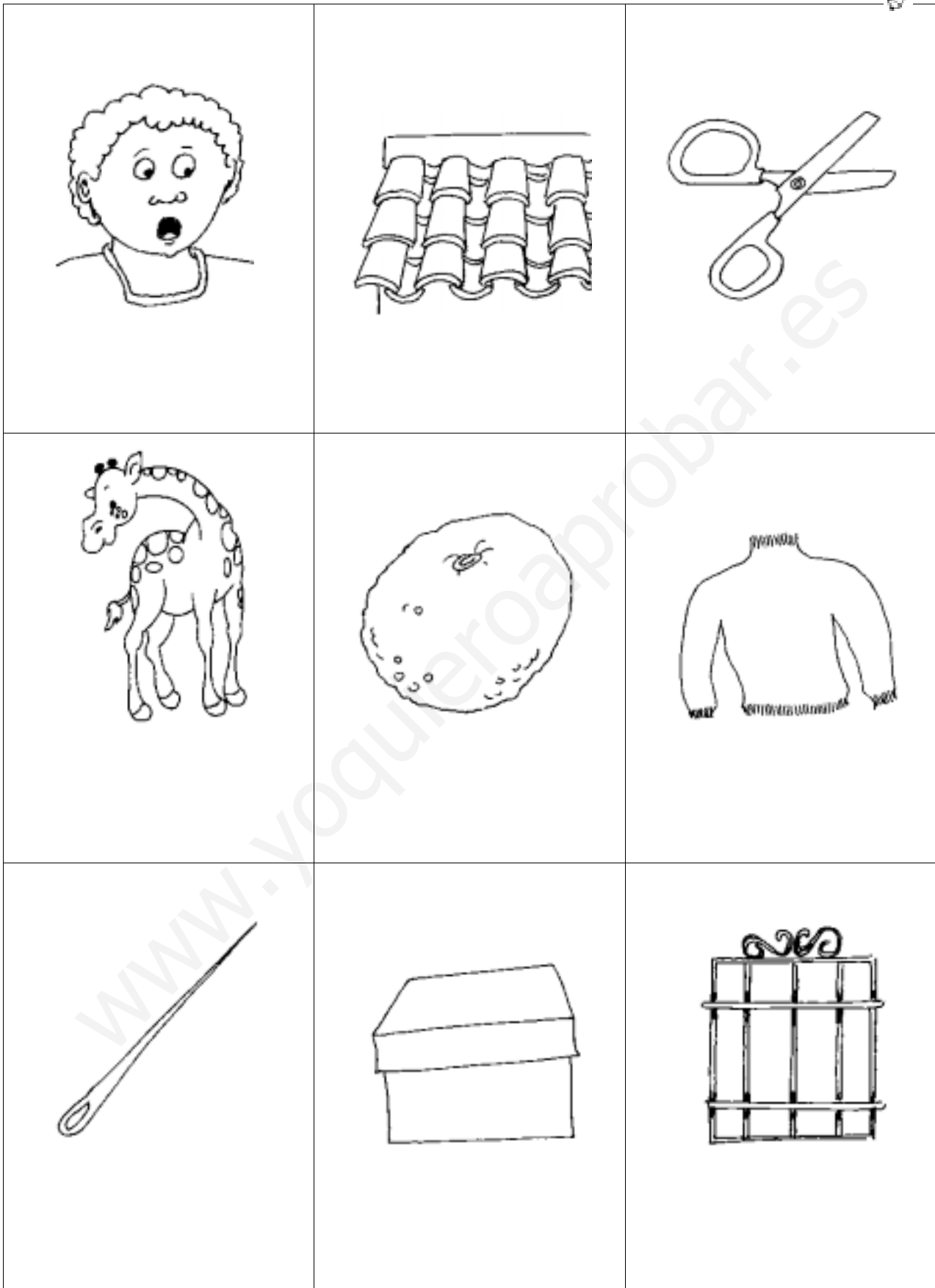



toma leche de la jarra

El perro muerde el 

Juan se pone el  rojo

La  se pierde en el pajar

Natalia juega con sus 



La jirafa come hojas.
Jaime se pone el pijama.
El pájaro sale del nido.
Como naranjas y peras.
La lagartija se asusta.
Me pincho con la aguja en el dedo.
Natalia juega con sus juguetes.
La jirafa es más alta que el tejado.



Handwriting practice lines consisting of multiple sets of three horizontal lines (top, middle, bottom) with a dotted line in the middle. Two small circles are placed at the beginning of the first two lines.



Tema 20	第二十课	Unit 20
La jirafa Garrafa.	长颈鹿哥拉发。	Garrafa the giraffe
Ésta es l jirafa Garrafa.	这是长颈鹿哥拉发。	This is Garrafa the giraffe
Es de color naranja y marrón.	它的皮是桔黄色和棕色。	She is prange and brown
Es muy alta.	它长得很高。	She is very tall
Más alta que el tejado.	它长得比屋顶还高。	She is taller than the roof
Come muchas hojas.	它吃很多叶子。	She eats a lot of leaves
¡Cuidado! Que te comes una lagartija.	小心吃着壁虎。	Look out! You are eating a wall lizard
		
La jirafa come hojas..	长颈鹿吃叶子。	The giraffe eats leaves
Jaime se pone el pijama.	哈尔美穿上睡衣	Jaime is putting the pyjamas on
El pájaro sale del nido.	小鸟飞出鸟窝。	The bird is coming out from the nest
Como naranjas y peras.	我吃橘子和梨。	I am eating some oranges and pears
La lagartija se asusta.	壁虎很害怕。	The wall lizard has got frightened
Me pincho con la aguja en el dedo.	我的手指被针扎了一下。	I have pricked my finger with the needle.
Natalia juega con sus juguetes.	娜塔丽阿玩她的玩具。	Natalia is playing with her toys
La jirafa es más alta que el tejado.	长颈鹿比房顶还高。	The giraffe is taller than the roof



ce ci

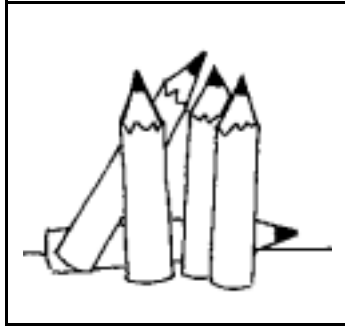

lápices

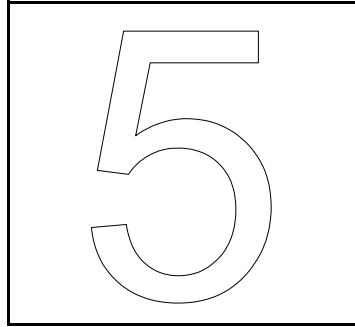

cinco

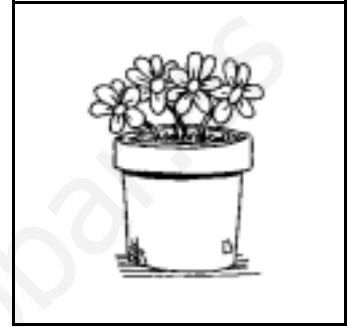

maceta



nueces

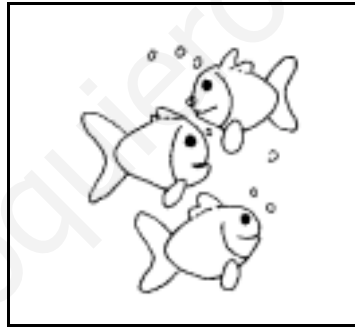

peces

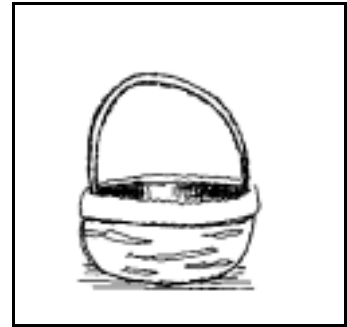

cesta



ciruela

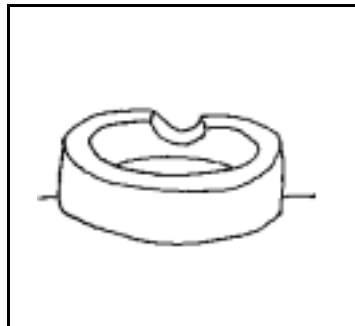

cenicero

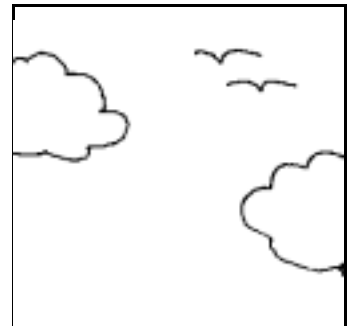

cielo

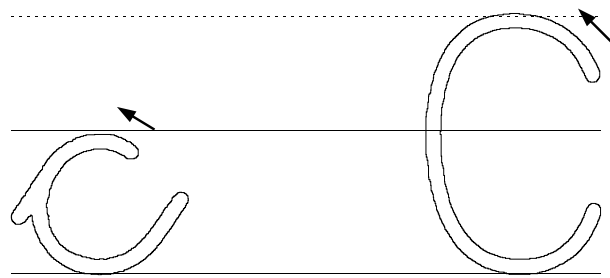

ce ci

Ce Ci

cesto maceta Cecilia Alicia
peces cisne Celia muñecas circo
lápices ciruela cenicero cielo
circo cerdo ciego calcetines.

Una maceta de rosas.

Alicia sale del parque.

Cecilia da comida a los peces.

Alí riega las macetas.

Hua pinta con lápices de
colores un lago con cisnes.

Jaime mira al cielo.



Ce Ci

ce ci

Los lápices de colores

El perro del ciego

El cerdo come ciruelas

Tengo cinco peces en la pecera

En el cesto hay nueces

Me pongo los calcetines

Me gusta mucho el circo chino

Cecilia riega las macetas



En la pecera hay cinco peces.

¿Cuántos peces hay en la pecera?

Alicia tiene ocho lápices.

¿Qué tiene Alicia?

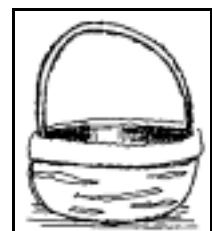
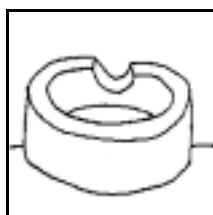
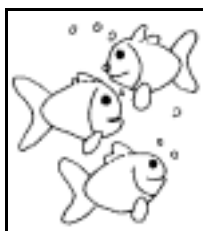
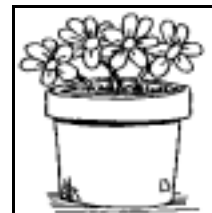
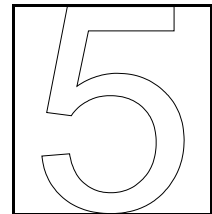
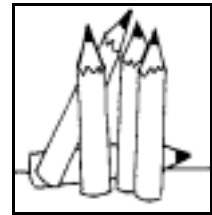
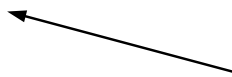

Cecilia
la ciruela
los lápices
el cinco
la maceta
las nueces
los peces
la cesta
el cenicero
el cielo



Cecilia



maceta



peces



lápices



ciruela



cesta



muecos

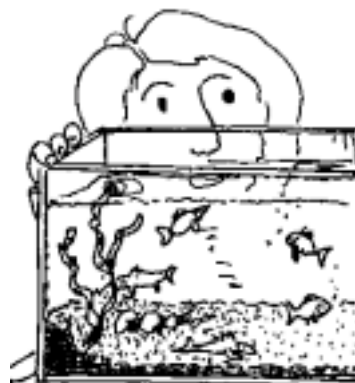

pecera



cielo



Cecilia riega las macetas

Handwriting practice lines consisting of a solid top line, a dashed middle line, and a solid bottom line.

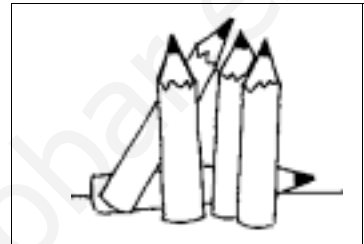

Los lápices de colores

Handwriting practice lines consisting of a solid top line, a dashed middle line, and a solid bottom line.

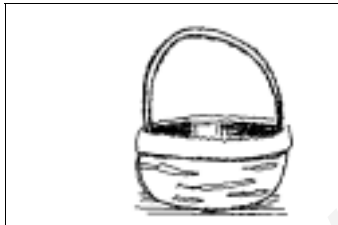

En la cesta hay nueces

Handwriting practice lines consisting of a solid top line, a dashed middle line, and a solid bottom line.

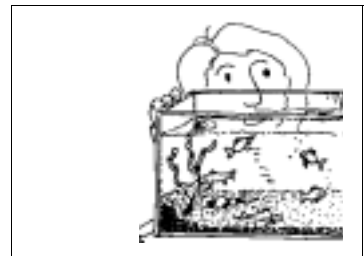

Tengo cinco peces en la pecera

Handwriting practice lines consisting of a solid top line, a dashed middle line, and a solid bottom line.



Uno

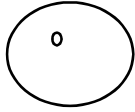

Muchos

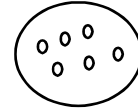

la cesta	las cestas
la maceta	
el cione	
la ciruela	
el cenicero	
el circo	
el cerdo	
el calcetín	
el ciego	

~~cesto~~ colores ciego cerdo camión
maceta cama saco cuna cielo

ce, ci
cesto

ca, co, cu



 <p>Leo...</p>	<p>Mi amiga Cecilia</p>	
		
<p>Ésta es Cecilia</p>	<p>Tiene muchas macetas</p>	<p>Las riega todos los días</p>
		
<p>Tiene una pecera con cinco peces</p>	<p>Le gusta pintar con lápices de colores</p>	<p>Le gustan mucho las ciruelas y los dulces</p>





Una  de margaritas

Cecilia da de comer a los 

En la  hay muchas 

Hua pinta con  de colores

Tengo  ciruelas moradas



Los lápices de colores.
Alicia sale al parque.
Tengo cinco peces en la pecera.
Como ciruelas moradas.
En el cesto hay nueces.
El cerdo come sandías y melones.
El perro del ciego.
Cecilia riega las macetas.



Handwriting practice lines with a watermark: www.yoquieroaprobar.es



Tema 21

第二十一课

Unit 21

Mi amiga Cecilia.	我的朋友赛西里亚。	My friend Cecilia.
Ésta es Cecilia.	这是赛西里亚。	This is Cecilia.
Tiene muchas macetas.	他有很多盆花。	She has a lot of flowerpots.
Las riega todos los días.	他每天浇花。	She waters them everyday.
Tiene una pecera con cinco peces.	他有一个鱼缸，里面有五条	She has a fish bowl with five fish in it.
Le gusta pintar con lápices de colores.	他喜欢用彩色笔画。	She likes painting with colored pencils.
Le gustan mucho las ciruelas y los dulces.	他很喜欢吃李子和糖果。	She likes plums and candy a lot.
		
Los lápices de colores.	彩色笔。	Colored pencils.
Alicia sale al parque.	阿里西亚去公园。	Alicia goes out to the park.
Tengo cinco peces en la pecera.	我有五条鱼，在鱼缸里。	I have five fish in the fish bowl.
Como ciruelas moradas.	我吃紫色的李子。	I am eating purple plums
En el cesto hay nueces.	篮子里有核桃。	There are some walnuts in the basket.
El cerdo come sandías y melones.	猪吃西瓜和哈密瓜。	The pig is eating some watermelon and melon.
El perro del ciego.	导盲犬。	The blind's dog.
Cecilia riega las macetas.	赛西里亚浇花。	Cecilia is watering the flowerpots.



ba be bi bo bu
ab eb ib ob ub

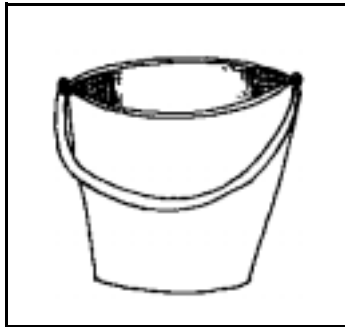
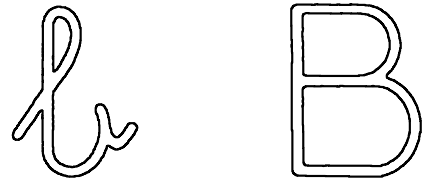

cubo

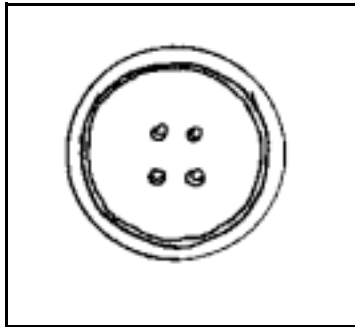

botón

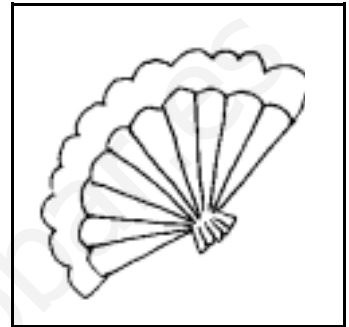

abanico

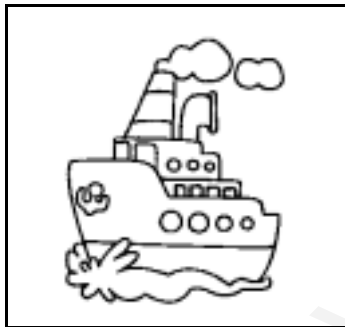

barco



autobús

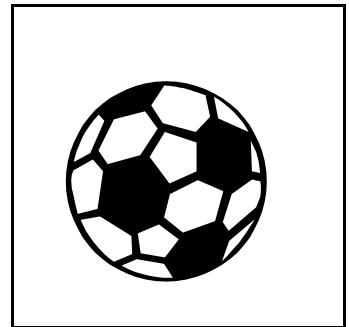

balón



Berta



liberón



abeto

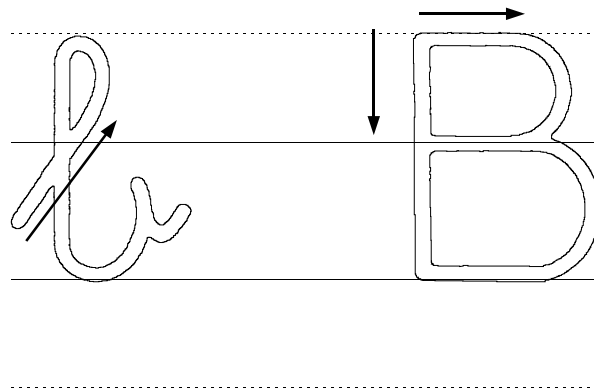

ba be bi bo bu
Ba Be Bi Be Bu

abanico banco barco balón
botones comba bombero abeto
búho autobús babi bueno bolsa
botas bonita bebida bebé nube
sábana baloncesto bombones
árbol boca labios. .

Berta juega al baloncesto.
Alí dibuja con lápices de
colores.

A Cecilia le gustan los
bombones de chocolate.



Ba Be Bi Bo Bu

ba be bi bo bu

Tengo un abanico rojo

Me siento en el banco

El barco tiene una chimenea

Aquí espero al autobús

El bombero apaga el fuego

En el cielo hay nubes

Berta juega al baloncesto

Cecilia come bombones



Como bombones de chocolate.

¿Qué es lo que como?

Berta tiene un babi muy bonito.

¿Qué tiene Berta?

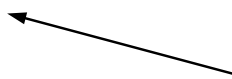
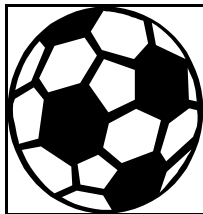
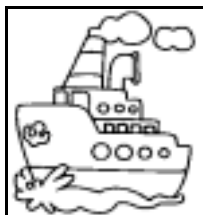

el barco
el cubo
el balón
las nubes
las botas
el babero
el babi
el abeto
el autobús
el abanico

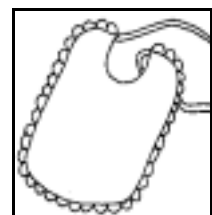
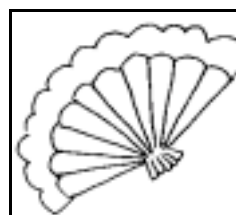
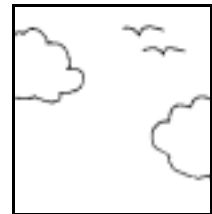



babero



bicho



hojas



bucro



botas



bata



biberón



Berta



autobús

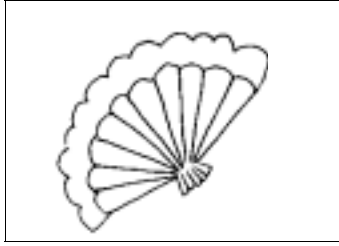

Tengo un abanico rojo

Handwriting practice lines consisting of a solid top line, a dashed middle line, and a solid bottom line.

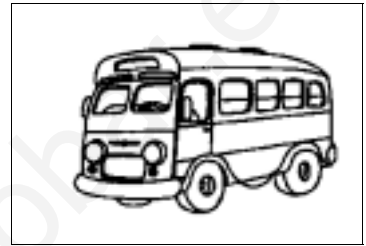

Aquí espero el autobús

Handwriting practice lines consisting of a solid top line, a dashed middle line, and a solid bottom line.

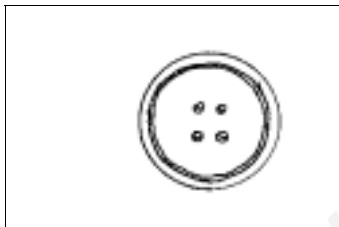

Coso el botón de la chaqueta

Handwriting practice lines consisting of a solid top line, a dashed middle line, and a solid bottom line.



El babi de Berta es muy bonito

Handwriting practice lines consisting of a solid top line, a dashed middle line, and a solid bottom line.



Uno

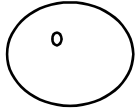

Muchos

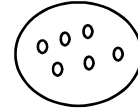

el liberón	los liberones
el botón	
el camión	
el autobús	
el bombón	
el árbol	
el balón	
el baúl	
el león	

~~cesto~~ colores ciego cerdo camión
maceta cama saco cuna cielo

ce, ci
cesto

ca, co, cu



 <p>Leo...</p>	<p>Berta es mamá</p>	
		
<p>Ésta es Berta</p>	<p>Ha tenido un bebé</p>	<p>Berta le pone el biberón</p>
		
<p>Berta le da el biberón</p>	<p>El bebé hace: lúa, lúa...</p>	<p>Berta le da muchos besos.</p>





El  tiene una chimenea

Aquí espero el 

 juega al baloncesto

Mina pinta el  de colores

Cecilia pone el  en la 



Tengo un abanico rojo.
Los patitos juegan al balón.
Berta juega al baloncesto.
Ali dibuja con lápices de colores.
Aquí espero el autobús.
Coso el botón de la chaqueta.
Hua tiene un babi muy bonito
A Cecilia le gustan los bombones de chocolate.



Handwriting practice lines consisting of multiple sets of three horizontal lines (top, middle, bottom) with a dotted line in the middle. Two small circles are placed at the beginning of the first two lines.



Tema 22	第二十二课	Unit 22
Berta es mamá.	贝尔塔是妈妈。	Berta becomes a mum.
Ésta es Berta.	这是贝尔塔。	This is Berta.
Ha tenido un bebé.	她有了小孩子。	She has had a baby.
Berta le pone el babero.	贝尔塔给他戴上围嘴儿。	Berta is putting him the bib on.
Berta le da el biberón.	贝尔塔给他吃奶瓶。	Berta is giving him his bottle.
El bebé hace, bua, bua...	小孩子发出：吧，吧的声	The baby is crying: waaah!
Berta le da muchos besos.	贝尔塔对他亲了又亲。	Berta is kissing him a lot.
		
Tengo un abanico rojo.	我有一把红扇子。	I have a red fan.
Los patitos juegan al balón.	小鸭子在玩球。	Little ducks are playing ball.
Berta juega al baloncesto.	贝尔塔玩篮球。	Berta is playing basketball.
Alí dibuja con lápices de colores.	阿里用彩色笔画画。	Alí is drawing with colored pencils.
Aquí espero el autobús.	我在这里等公共汽车。	I wait for the bus here.
Coso el botón de la chaqueta.	我缝外套的纽扣。	I am sewing the button of the jacket
Hua tiene un babi muy bonito.	华有一件很漂亮的罩衫。	Hua has such a pretty overall.
A Cecilia le gustan los bombones de chocolate.	赛西里亚喜欢巧克力。	Cecilia likes chocolates.



ña ñe ñi ño ñu

ñ Ñ

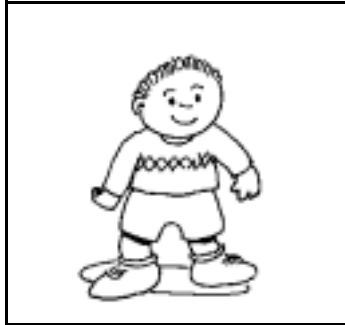

niño

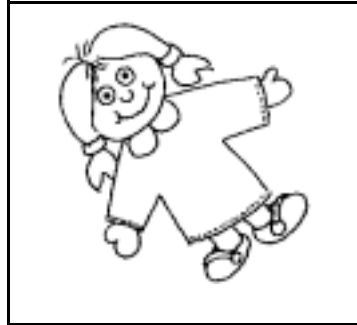

muñeca

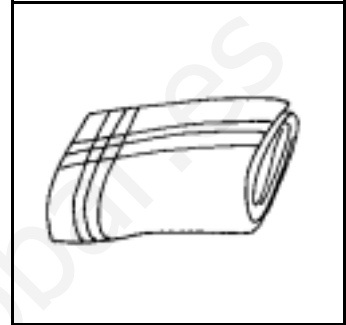

pañuelo

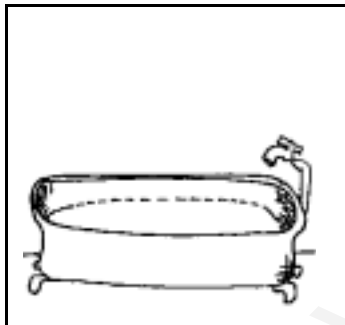

bañera

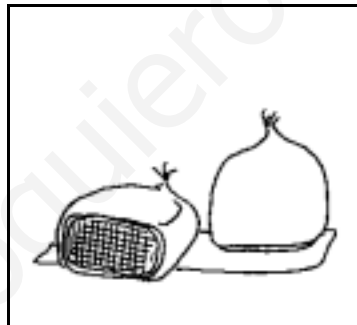

castañas

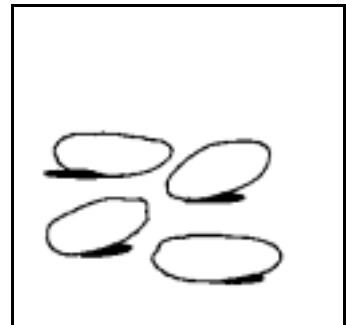

piñones



uña



cabaña

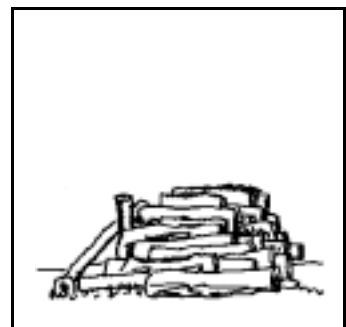

leña

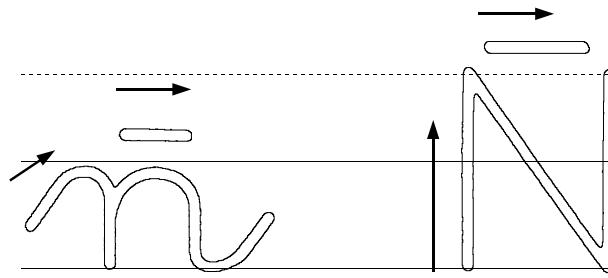

na ne ni ñe nu
 Na Ne Ni Ñe Nu

niño pañuelo muñeca ñu
 castaña bañera cabaña uña
 niña muñeco leña leñador
 muñeco muñequera bañador
 pita pitones pañoleta paño

Fátima se pone el pañuelo.
 Miguel se mete en la cabaña.
 Papá echa leña al fuego.
 Me duele la uña.
 Pongo el bañador al muñeco.
 Los niños juegan al cerro.



Na Ne Ni No Nu

na ne ni no nu

Las niñas juegan en la arena

La muñeca de Teñi es bonita

Fátima se pone la pañolera

Como castañas y piñones

Papá pone mucha leña

Me pongo el bañador rojo

Berta juega con su muñeco

El leñador cuida el abeto



Toñi tiene una muñeca.

¿Qué tiene Toñi?

La muñeca tiene un labi rojo.

¿Qué tiene la muñeca?

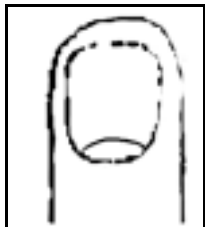
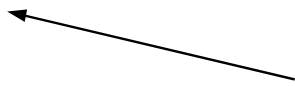

Toñi
 la niña
 los piñones
 la cabaña
 la uña
 el pañuelo
 la muñeca
 las castañas
 la leña
 el niño

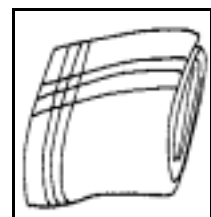
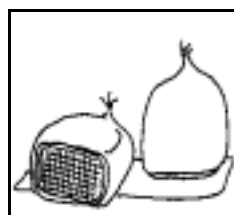
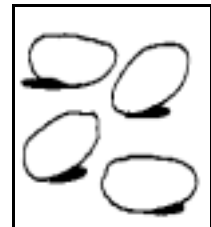



mujerica



Teti



cabaña

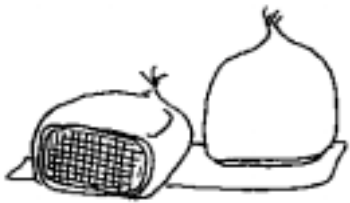

castañas



piñones



urina



bañera



nino

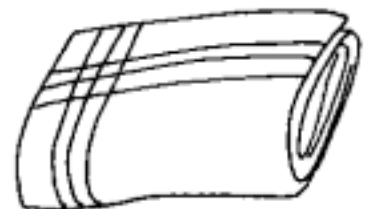

pañuelo



Toñi juega con su muñeca

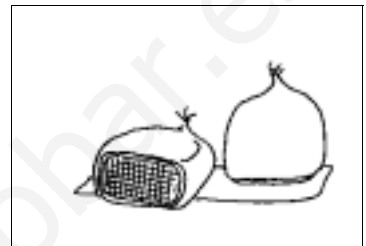

Como castañas y piñones



La niña juega con el balón



El bali de la muñeca es rojo



Delante de r y l ponemos m

bombón	bombón
bombero	bo__bero
compás	co__pás
campana	ca__pana
pampa	pa__pa
campo	ca
bambalina	ba
gamba	
cambiar	

~~niño~~ nena Toñi leña bueno
bañera cuna año nube tuno

ñ
nino

n



 <p>Leo...</p>	<p>La muñeca de Toñi</p>	
		
<p>Toñi tiene una muñeca. La quiere mucho</p>	<p>Todos los días la baña en la bañera</p>	<p>Luego le corta las uñas y la peina</p>
		
<p>Le pone un babi de paño rojo</p>	<p>Luego le da de comer: despacio o te hará daño</p>	<p>Ahora a dormir, que tienes mucho sueño.</p>

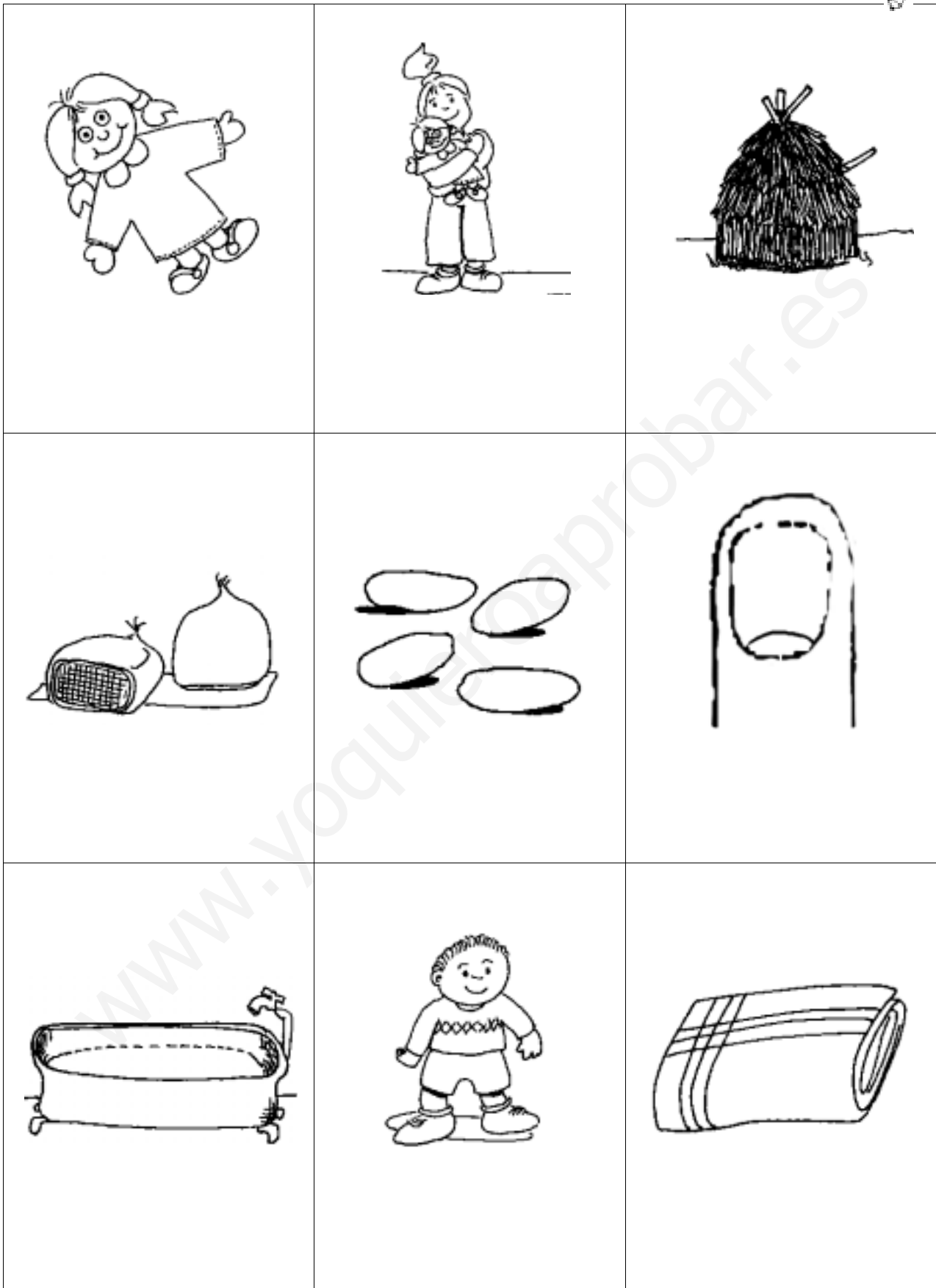



Toñi juega con su



Como



y



La



juega en la arena

La



de la muñeca es roja

Papá pone



en el fuego



Toñi juega con su muñeca.
Los niños juegan en la arena.
El bali de la muñeca es rojo.
Berta come castañas y piñones.
Fátima se pone el pañuelo en el pelo.
Toñi cuida la bañera y el bali de la muñeca.
Papá pone leña en el fuego para que no se apague.



Handwriting practice area with multiple sets of horizontal lines (solid top and bottom lines, dashed middle line) for writing practice.



Tema 23	第二十三课	Unit 23
La muñeca de Toñi.	托尼的娃娃。	Toñi's doll.
Toñi tiene una muñeca. La quiere mucho.	托尼有一个娃娃。他很爱	Toñi has a doll. She loves her a lot.
Todos los días la baña en la bañera.	每天在浴缸里给它洗澡。	She gives her a bath every-day.
Luego le corta las uñas y la peina.	然后她给它剪指甲，给她梳	After it, she cut her nails and combs her hair.
Le pone un babi de paño rojo.	她给娃娃穿上红色的罩衫	She puts her on a red wollen cloth overall.
Le da de comer: despacio o te hará daño.	然后喂它吃饭：慢点，否则	She feeds her: "if you don't eat slowly, it will hurt you"
Ahora a dormir, que tienes mucho sueño.	现在睡觉，你很困了。	Go to bed now, as you are very sleepy.
		
Toñi juega con la muñeca.	托尼跟娃娃一起玩。	Toñi is playing with the doll.
Los niños juegan en la arena.	孩子们玩沙子。	The children are playing on the sand.
El babi de la muñeca es rojo.	娃娃的罩衫是红色的。	The overall of the doll is red.
Berta come castañas y piñones.	贝尔塔吃栗子和松子。	Berta is eating some chestnuts and pine nuts.
Fátima se pone el pañuelo en el pelo.	法提玛戴上了围巾。	Fátima puts a headscarf on.
Toñi cuida la bañera y el babi de la muñeca.	托尼小心使用浴缸和娃娃的	Toñi takes care of the bath and the overall of the doll.
Papá pone la leña en el fuego para que no se apague.	爸爸把木柴放在火里使火不	Dad is throwing some wood into the fire so that it doesn't go out



ya ye yi yo yu

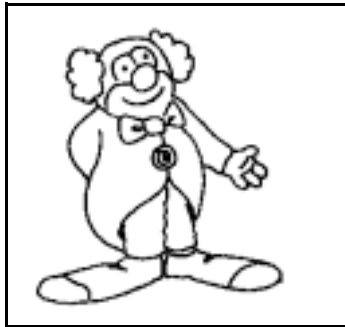
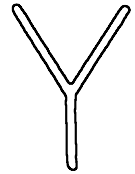
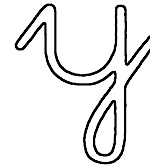

payaso

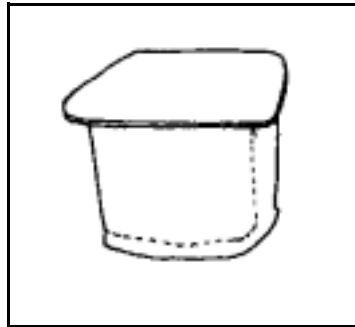

yogur

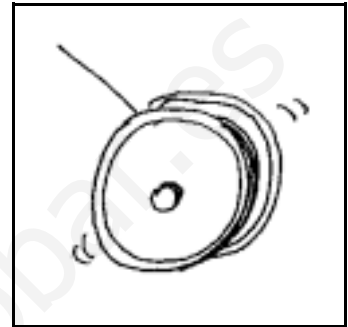

yoyo

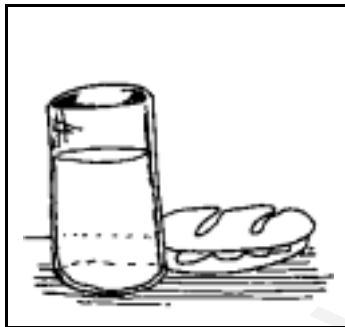

desayuno

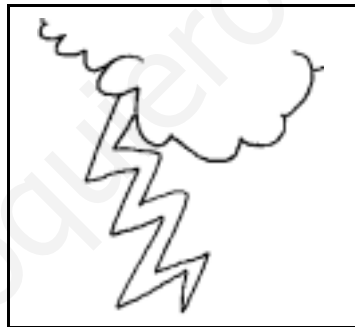

rayo

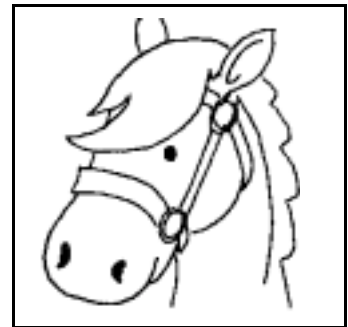

yegua



mayúsculas



mayonesa



joya

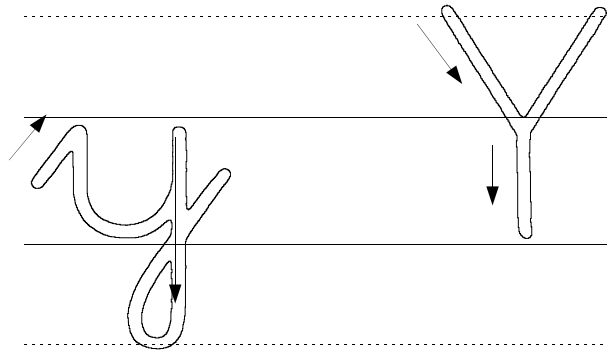

ya ye yi yo yu
Ya Ye Yi Yo Yu

yo Yolanda yate yaya yogur
yoyo payaso mayúscula joya
mayonesa yegua playa rayo
papagayo yema tuya hoyo

Yolanda se come la joya.
Pongo la M mayúscula.
De la nube sale el rayo.
Como pan con mayonesa.
La yegua se baña en el río.
El payaso hace reír.
Tengo un yate de juguete.



Ya Ye Yi Ye Yu

ya ye yi ye yu

La yegua se mete en el lago

Yolanda juega en la playa

Alí come yogur con piñones

Papá regala un yoyo a su hijo

Desayuno leche con chocolate

El payaso entra en el circo

La familia de Hua sube al yate

Mamá compra una joya



Rafa tiene un yoyo.

¿Qué tiene Rafa?

Desayuno leche con chocolate.

¿Qué desayuno?

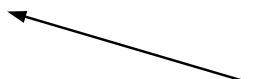

el yate
 las mayúsculas
 el yogur
 el yoyo
 el desayuno
 la yegua
 la joya
 el payaso
 el rayo
 la mayonesa

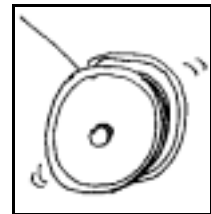
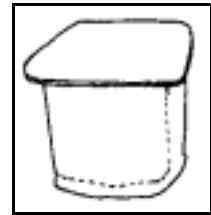



yogur



yate



yegua

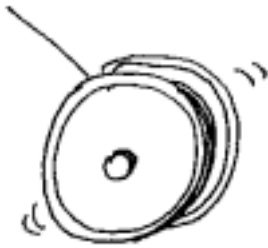

yoyo

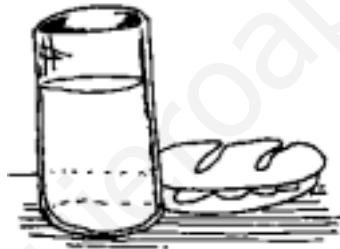

desayuno



mayonesa



rayo



joya



payaso

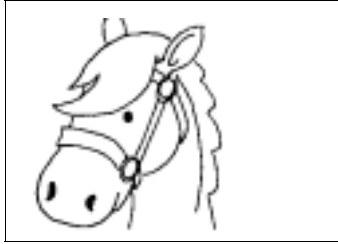

La yegua se mete en el lago



Ali come yogur con piñones

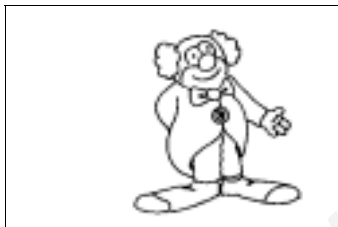

El payaso juega con el yoyo



Desayuno chocolate con leche



YA Pongo en mayúsculas

hoy	HOY
yoyo	YOYO
yate	Y
yogur	
rayo	
mayonesa	
camión	
peces	
tijeras	

~~yate~~ mochila coche yoyo payaso mucho
poncho mayonesa chimenea rayo







ya ye yi yo yu
yate

cha che chi cho chu



 <p>Leo...</p>	<p>El payaso Agustín</p>	
		
<p>Agustín es un payaso</p>	<p>Actúa en el circo</p>	<p>Se monta en la yegua</p>
		
<p>Hace piruetas y da saltos</p>	<p>Juega con un yoyo</p>	<p>Todos se ríen mucho.</p>





Rafa juega con su



Como



con



La



juega con el agua

Me asusta el



Toñi regala una



a su mamá



La yegua se mete en el lago
Yolanda juega en la playa
Ali come yogur con piñones
Papá regala un yoyo a su hijo
Desayuno leche con chocolate
El payaso entra en el circo
La familia de Hua sube al yate
Toñi compra una joya a su mamá



Handwriting practice lines with a watermark: www.yoquieroaprobar.es



Toñi es una niña rubia.
Toñi tiene ocho años.
Su abuela le regala una muñeca.
Mañana irá a la montaña de paseo.



COMPLETA

Toñi es una _____ rubia.

Su abuela le regala una _____.

Toñi tiene ocho _____.

Mañana irá de _____ a la _____.

CONTESTA

¿Quién es Toñi?

¿Qué le regaló su abuela?

¿Cuántos años tiene Toñi?



CONTESTA

¿Quién es? _____

Coloreo la chaqueta de color rojo.

Coloreo los pantalones de color amarillo.



Tema 24	第二十四课	Unit 24
El payaso Agustín.	小丑阿古斯丁。	Agustín the clown.
Agustín es un payaso.	阿古斯丁是小丑。	Agustín is a clown.
Actúa en el circo.	在马戏团表演。	He acts in the circus.
Se monta en la yegua.	他骑着一匹母马。	He rides the mare.
Hace piruetas y da saltos.	旋转和跳跃。	He performs pesades and jumps.
Juega con el yoyo.	玩约约(一种小孩玩具)。	He plays with the yo-yo.
Todos se ríen mucho.	大家都高兴地笑。	Everybody laughs a lot.
		
La yegua se mete en el lago.	母马走进湖里。	The mare goes into the lake.
Yolanda juega en l playa.	幽兰达在海滩玩。	Yolanda is playing at the beach.
Alí como yogur con piñones.	阿里吃酸奶和松子。	Alí is eating some yogurt with pine nuts.
Papá regala un yoyo a su hijo.	爸爸送给他孩子一个约约。	Dad is giving a yo-yo to his son as a present.
Desayuno leche con chocolate.	我早饭吃巧克力牛奶。	I have milk with chocolate for breakfast.
El payaso entra en el circo.	小丑进马戏团。	The clown is coming into the circus.
La familia de Hua sube al yate.	华的家人上了游艇。	Hua's family is going up to the yacht.
Toñi compra una joya a su mamá.	托尼买一个首饰给她妈妈。	Toñi is buying a piece of jewelry for her mum.



za zo zu

az ez iz oz uz

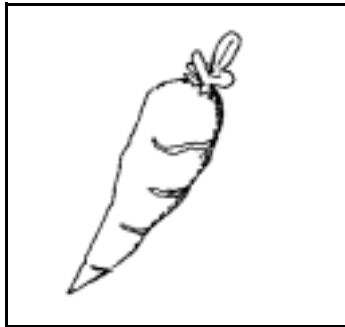

zanahoria

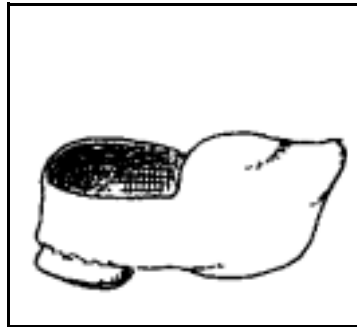

zueco

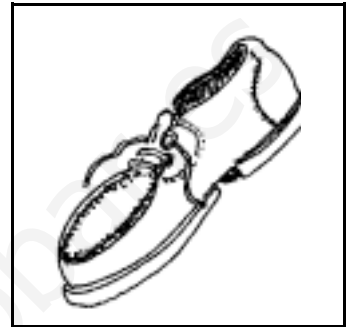

zapato

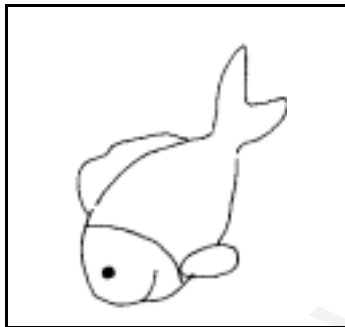

pez

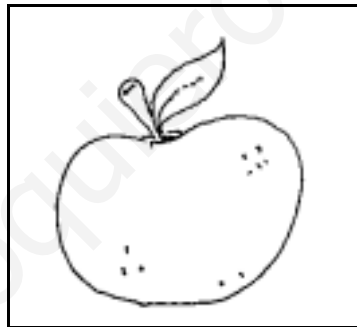

manzana

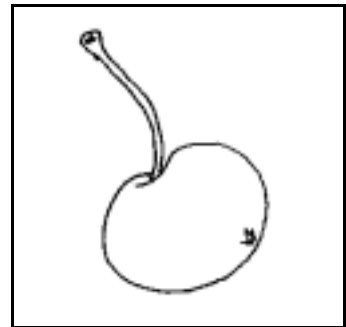

cereza



zambomba



zumos

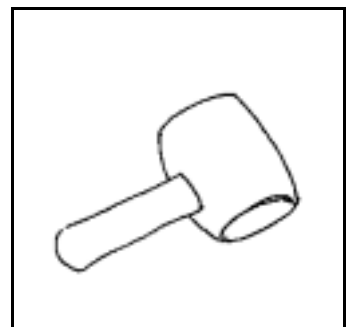

mazo

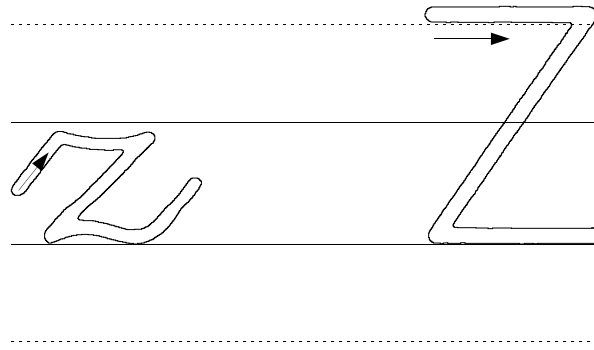

za zo zu Za Zo Zu
az ez iz ez uz

zambonía zueco zapato pez
manzana cereza mazapán
zambomba zumo mazo lazo
azul anuelo raíz zoco

El zapato tiene un lazo.
Un manzano con manzanas.
El cerro bebe agua en el río.
Tengo un pastel de cerezas.
Este lápiz es de color azul.
La taza de café está caliente.
El buzo sale del agua.



Za Ze Zu

za ze zu

El agua está en el pozo

Como un helado de cerezas

Desayuno zumo de naranjas

El cielo es de color azul

La azteca está arriba

Nadia tiene un lazo en el pelo

Dame esa taza de café

Mamá sale a la terraza



Yi toma zumo de naranjas.

¿Qué toma Yi?

Este zapato me queda pequeño.

¿Cómo te queda el zapato?

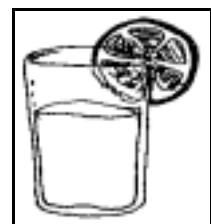
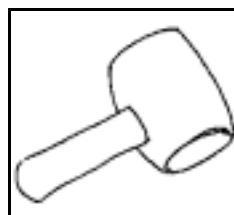
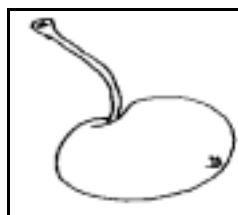
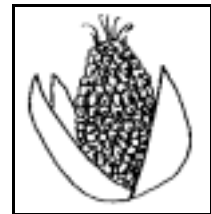
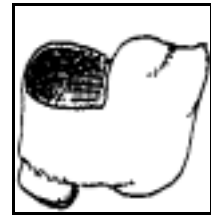

el pez
 la manzana
 el zueco
 el maíz
 el zapato
 la zanahoria
 la cereza
 el mazo
 el zumo
 la zambomba



manzana

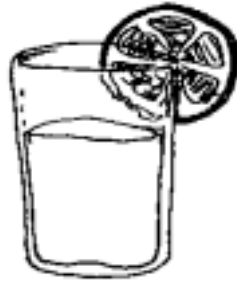

zumo



mazo



anzuelo



maíz



lazo



zanahoria



pez



zapato



Este zapato me queda pequeño

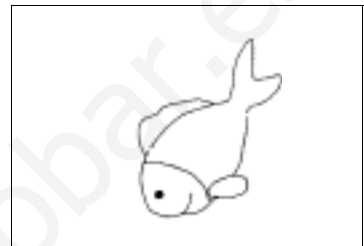

El pez nada en el estanque

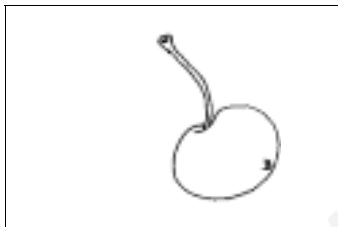

Me como una tarta de cerezas



Desayuno zumo de naranjas



Escribe un o una

un albornoz	_____ terraza
una luz	_____ mozo
_____ yate	_____ taza
_____ yogur	_____ lápiz
_____ rayo	_____ zorro
_____ mayonesa	_____ manzana
_____ camión	_____ buzo
_____ pez	_____ lazo
_____ zumo	_____ cereza

~~cielo~~ zorro choza ceja pozo cerrojo
buzo cocido zapato ciego

ce ci
cielo

za zo zu



 <p>Leo...</p>	<p>El pez Azulín</p>	
		
<p>Azulín es un pez pequeñito</p>	<p>Es de color azul celeste</p>	<p>Nada en el río con su familia</p>
		
<p>Quiero salir del agua, mamá</p>	<p>No puedes, Azulín</p>	<p>¡Cuidado con el anzuelo!</p>

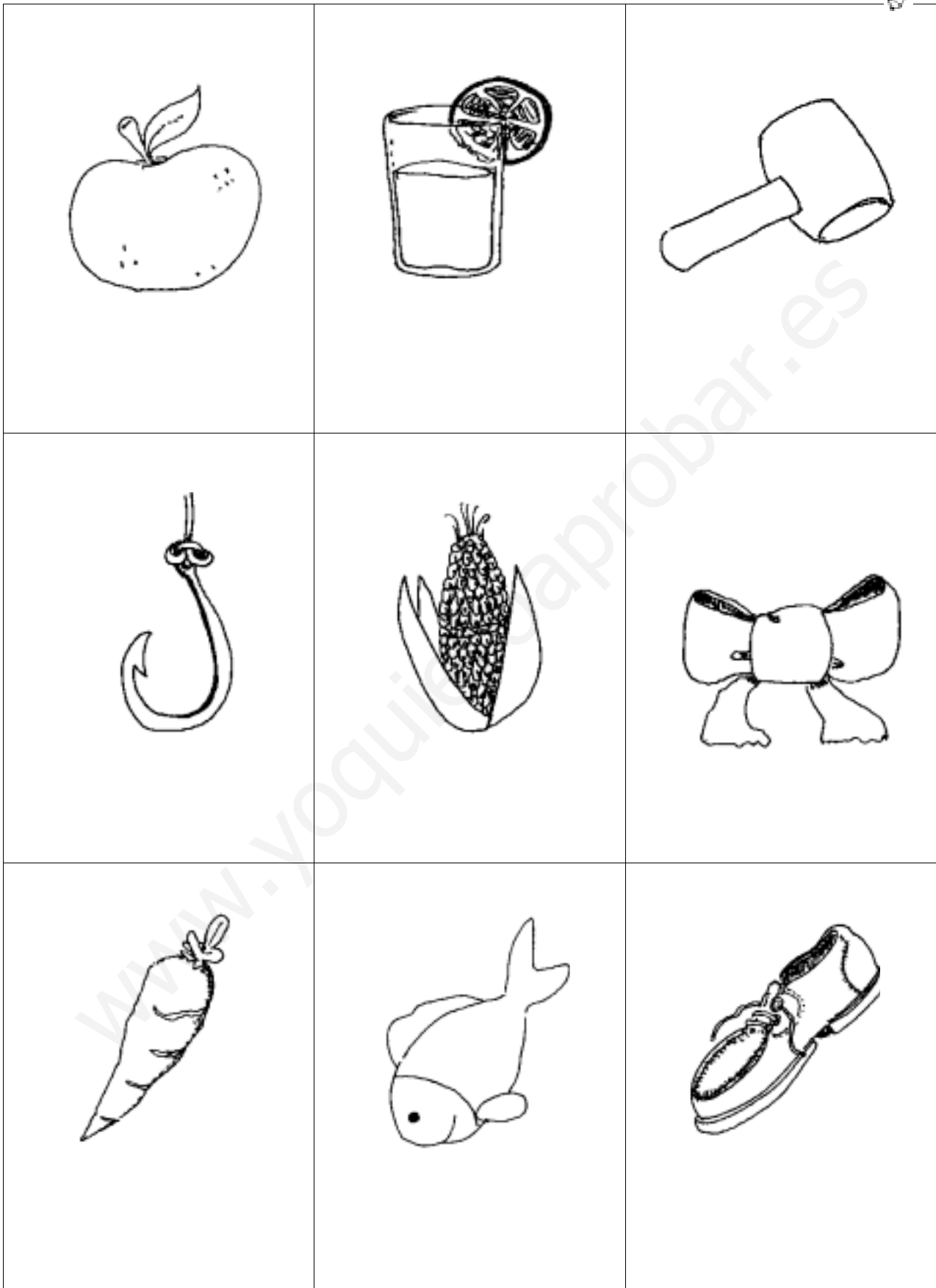



Yi come  con la ensalada

Como  y 

El  escapa del 

Me gusta el  de 

Hace un  a su 



El zapato tiene un lazo.
Un manzano con manzanas.
El zorro bebe agua en el rio.
Tengo un pastel de cerezas.
Los zuecos son zapatos de madera
La taza de café está caliente.
El buzo sale del agua.
Este lápiz es de color azul.



Handwriting practice lines with a watermark: www.yoquieroaprobar.es



Tema 25

第二十五课

Unit 25

El pez Azulín.	小鱼阿祖林	Azulín the fish.
Azulín es un pez pequeñito.	阿祖林是一条小鱼	Azulín is a little fish.
Es de color azul celeste.	他是天蓝色的	He is sky-blue.
Nada en el río con su familia.	他在河里跟他的家人一起游	He swims in the river with his family.
Quiero salir del agua, mamá.	我要走出水,妈妈	Mummy, I want to go out from water.
No puedes, Azulín.	你不可以的,阿祖林	You can't, Azulín.
¡Cuidado con el anzuelo!	小心鱼钩	Look out for the hook!



El zapato tiene un lazo.	鞋上有一条蝴蝶结	The shoe has a ribbon.
Un manzano con manzanas.	一棵苹果树有苹果	An apple tree with some apples on it.
El zorro bebe agua en el río.	狐狸在河里喝水	The fox drinks some water at the river.
Tengo un pastel de cerezas.	我有一各樱桃蛋糕	I have a cherry cake.
Los zuecos son zapatos de madera.	木头做的鞋子	Clogs are wooden shoes.
La taza de café está caliente.	咖啡杯里的咖啡还热的.	The cup of coffee is hot.
El buzo sale del agua.	潜水员从水里出来.	The diver is coming out from water.
Este lápiz es de color azul.	这支笔是蓝色的.	This pencil is blue.



lla lle lli llo llu

ll LL ll

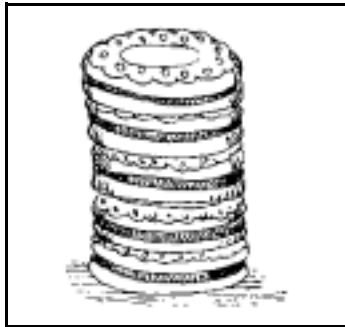

galletas

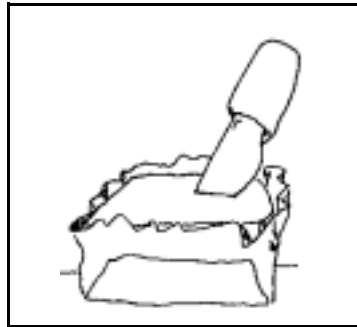

mantequilla

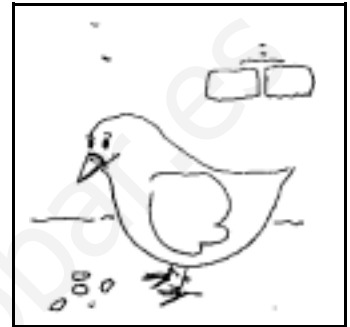

pollito

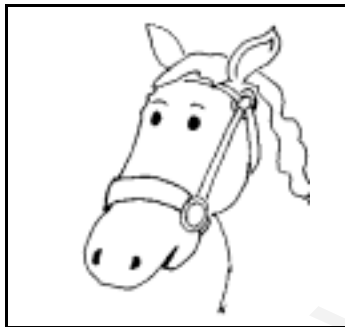

caballo



ballena



botella



camello



paella



botlos

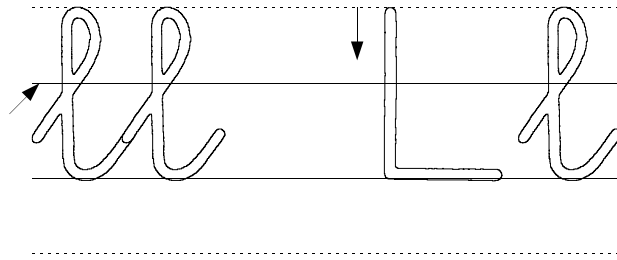

lla lle lli llo lli

gallo gallina tortilla amarillo
paella bollos cuello camello
pollito galletas mantequilla
caballo ballena botella lleno

Como galletas con mantequilla.
Papá gallo y mamá gallina.
El caballo y la yegua.
La ballena come gambas.
Esta botella está llena.
El camello bebe agua.
Me gustan los bollos con aceite.
La paella tiene mucho arroz.



Lla Lle Lli Llo Llu

lla lle lli llo llu

Pinto de color amarillo

Como tortilla y queso

Desayuno hellos y leche

Me pongo un collar al cuello

El camello tiene dos jorobas

Alí come arroz con pollo

El pollo se sube a la azotea

Mamá llena la botella de agua



A Natacha le pica el cuello.

¿Qué le pica a Natacha?

Su papá le pone pomada.

¿Qué le pone su papá?



el camello
 el cuello
 los bollos
 la paella
 la tortilla
 la gallina
 el gallo
 la botella
 la mantequilla
 el caballo

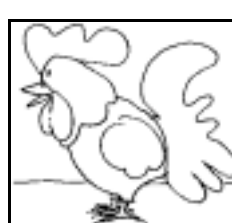
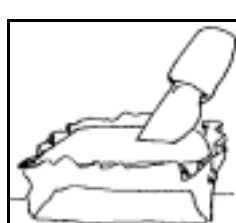



gallo



gallina



tortilla



paella



bollos



cuello



camello

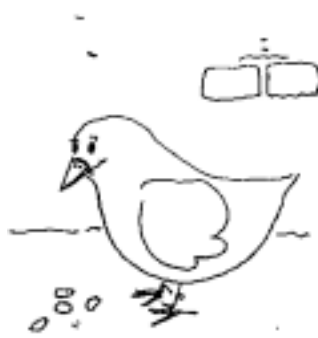

pollito

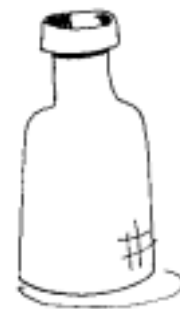

botella

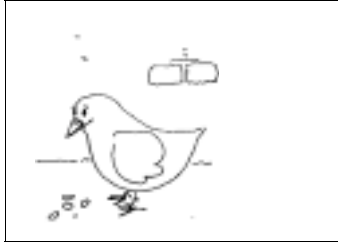

El pollito come maíz

.....

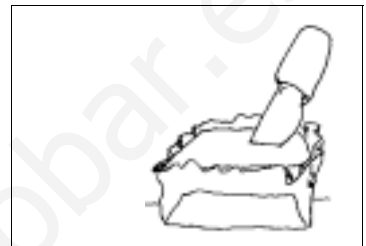

Meriendo galletas con mantequilla

.....



Lleno la botella de agua

.....



El camello descansa en el oasis

.....



Escribe el o la

la choza	_____ balena
el mozo	_____ bollo
_____ cereza	_____ taza
_____ paella	_____ gallina
_____ pollito	_____ gallo
_____ caballo	_____ tortilla
_____ yegua	_____ camello
_____ botella	_____ cometa
_____ mantequilla	_____ hilo

~~paella~~ yema pollito caballo yegua
yaya hueyes botella playa gallo

lla lle lli llo llu
paella



ya ye yi yo yu

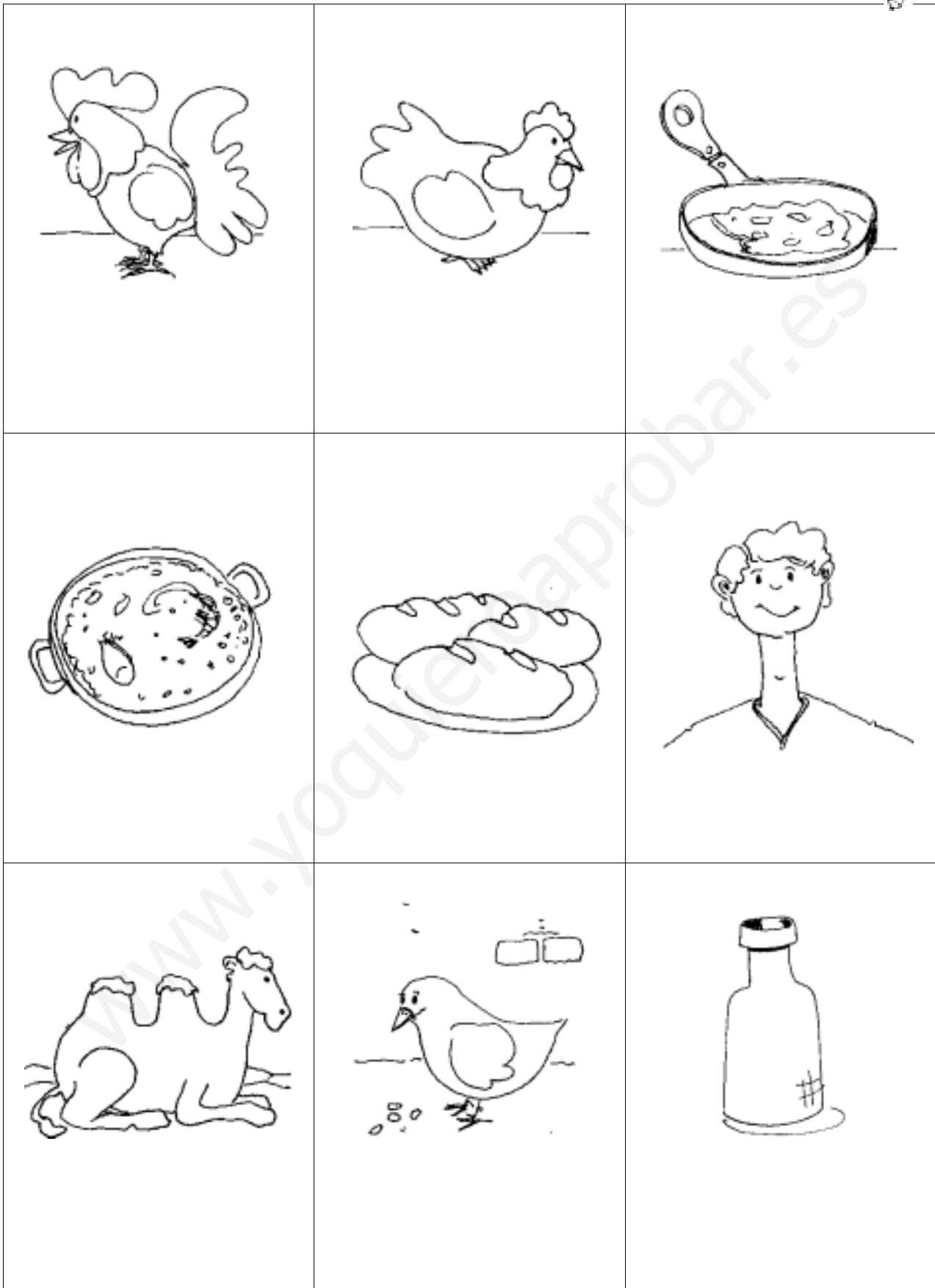

 <p>Leo...</p>	<p>El gallinero</p>	
		
<p>En el gallinero de Ana está el gallo Perico</p>	<p>Y la gallina Cocorocó</p>	<p>Tienen muchos pollitos amarillos</p>
		
<p>Ana da de comer maíz a los pollitos</p>	<p>El pollito Guillermo es un pillo</p>	<p>No quiere maíz, quiere galletas.</p>





En el  de Ana hay 

Lleno la  de agua fría

El  descansa en el oasis

Como  de marisco

Hace una  en la sartén



Pinto de color amarillo
Como tortilla y queso
Desayuno bollos y leche
Me pongo un collar al cuello
El camello tiene dos jorobas
Alí come arroz con pollo
El pollo se sube a la azotea



Handwriting practice lines with a watermark: www.yoquieroaprobar.es



Tema 26	第二十六课	Unit 26
El gallinero.	鸡窝	The henhouse.
En el gallinero de Ana está el gallo Perico.	贝利可公鸡在安娜的鸡窝	Perico the cock is in Ana's henhouse.
Y la gallina Cocorocó.	还有可可罗可母鸡	So Cocorocó the hen is.
Tienen muchos pollitos.	他们有很多只黄色小鸡	They have a lot of little chickens.
Ana da de comer maíz a los pollitos.	安娜给小鸡们吃玉米	Ana feeds the chickens with some corn.
El pollito Guillermo es un pillo.	归叶模小鸡很滑头	Guillermo the chicken is a rascal.
No quiere maíz, quiere galletas.	他不要玉米，他要饼干	He doesn't want any corn, he wants some biscuits.
		
Pinto de color amarillo.	我用黄色上颜色	I am painting it yellow.
Como tortilla con queso.	我吃鸡蛋土豆饼和奶酪	I am eating some omelette with cheese.
Desayuno bollos con leche.	我早餐吃面包和牛奶	I have some buns with milk for breakfast.
Me pongo un collar al cuello.	我在脖子上戴上一条项链	I am putting a necklace on.
El camello tiene dos jorobas.	骆驼有两个驼峰	The camel has two humps.
Alí come arroz con pollo.	阿里吃鸡炒饭	Alí is eating some rice with chicken.
El pollo se sube a la azotea.	鸡爬到屋顶上	The chicken is going up to the terrace roof.



ge gi Ge Gi

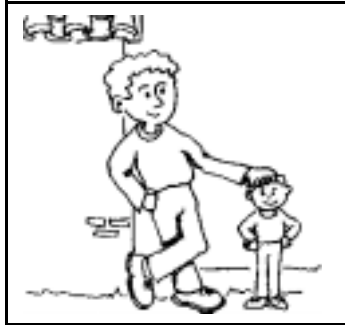

gigante



geranio

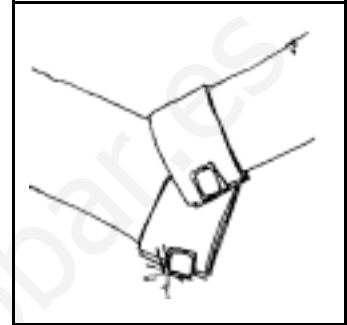

gemelos



gente



genio

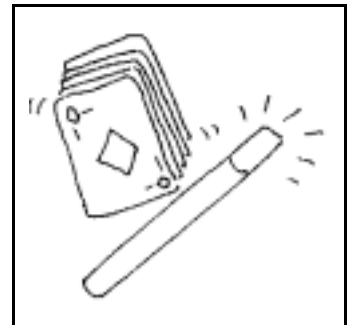

magia



colegio



Sergio

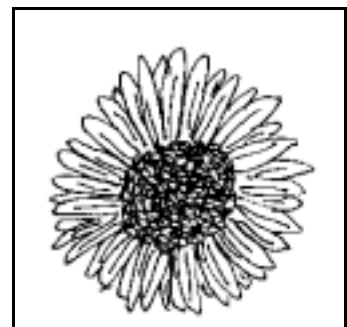

girasol



ge gi Ge Gi

Ge Gi ge gi

girasol gente geranio gemelos
gigante magia colegio genio
Sergio gentío colegiata gesto

El girasol es amarillo
Sergio tiene gafas pequeñas
El genio hace magia
Me gusta el colegio
En la calle hay mucha gente
Esta maceta tiene un geranio
Tengo unos gemelos de oro
Manolón es un niño gigante
A Sergio le gusta el colegio.



Ge Gi

ge gi

El girasol es de color amarillo

Como pipas de girasol

Llego al colegio corriendo

El genio sale de la lámpara

Me pongo los gemelos de oro

A Sergio le gusta la magia

Riego la maceta de geranios

Ángela y Manolón son amigos



Como pipas de girasol.

¿Qué es lo que como?

Sergio riega la maceta de geranios.

¿Qué es lo que riega Sergio?

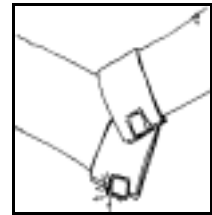
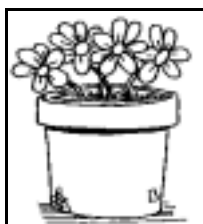
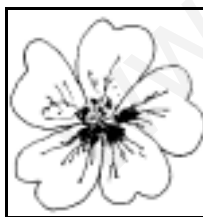

los gemelos
 la gente
 el genio
 el gigante
 la magia
 el geranio
 la maceta
 el colegio
 Sergio
 el girasol



girasol



gigante



geranio



gente



Sergio



colegio



magia



genio

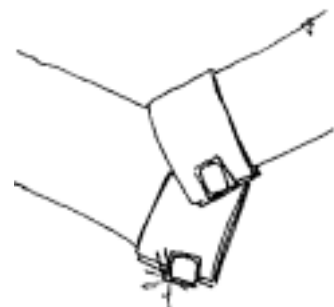

gemelos

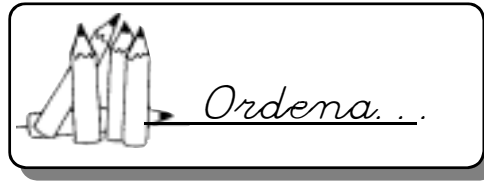
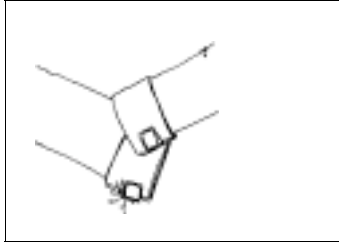

gemelos. Paco tiene unos

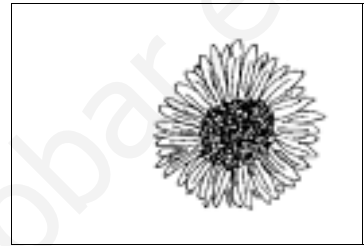

pipas Mina come de girasol.



le gusta magia. A Sergio la



de geranio riega. Hua la maceta



GRANDE



pequeño



la taza	la tacita
la cereza	la cerecita
el pozo	el pocito _____
el lazo	el l. _____
la choza	
el mozo	
la terraza	
el lápiz	
el pez	

~~gente~~ yogur Ángela mago gemelos
magia gallo girasol gusano goma

ge gi	ga go gu
gente	



 <p>Leo...</p>	<p>El gigante Manolón</p>	
		
<p>Manolón es un niño gigante</p>	<p>Como todos los gigantes es enorme</p>	<p>Tiene muy mal genio</p>
		
<p>Aunque es bueno, asusta a la gente</p>	<p>Manolón quiere ir al colegio</p>	<p>Ángela le dice: Seremos amigos, Manolón.</p>

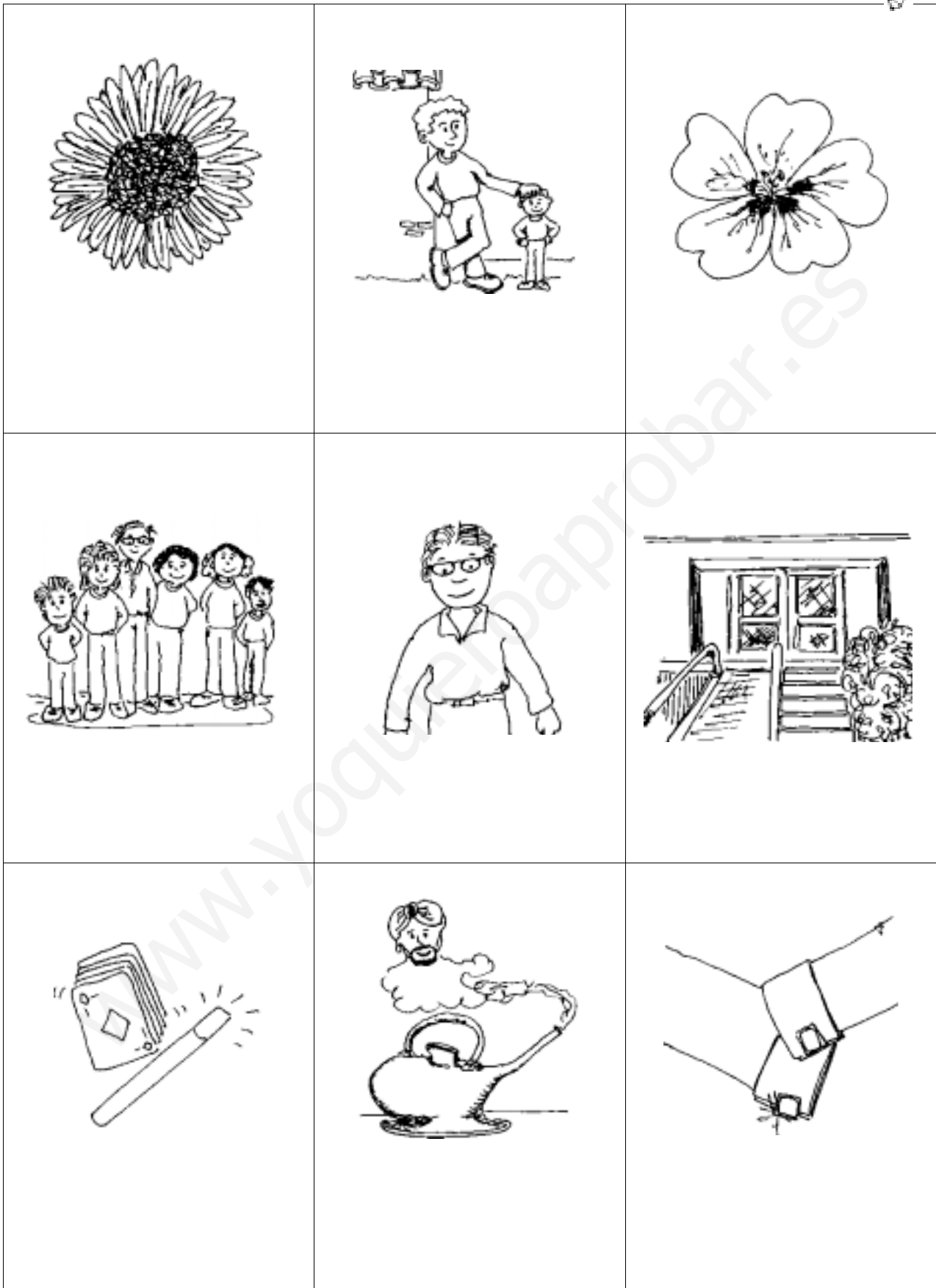



Papá tiene  en la camisa

Fátima come pipas de 

A  le gusta la 

Ana riega la  de 

Manolón quiere ir al 



El girasol es de color amarillo
Como pipas de girasol
Llego al colegio corriendo
El genio sale de la lámpara
A Sergio le gusta la magia
Riego la maceta de geranios
Ángela y Manolón son amigos



Handwriting practice lines consisting of a solid top line, a dashed middle line, and a solid bottom line. Two small circles are placed on the first two lines for starting points.



Tema 27	第二十七课	Unit 27
El gigante Manolón.	巨人马农龙	Manolón the giant.
Manolón es un niño gigante.	马农龙是个巨人孩子	Manolón is a giant boy.
Como todos los gigantes es enorme.	像所有的巨人一样他长得很	He is enormous, as all giants are.
Tiene muy mal genio.	他的脾气很暴躁	He has a very bad temper.
Aunque es bueno, asusta a la gente.	虽然他很善良，别人却都很	Although he is nice, he frightens people.
Manolón quiere ir al colegio.	马农龙想去学校	Manolón wants to go to school.
Ángela le dice: Seremos amigos, Manolón.	安吉拉对他说：我们是好朋	Ángela tells him: "We will be friends, Manolón"
		
El girasol es de color amarillo.	向日葵是黄色的	The sunflower is yellow.
Como pipas de girasol.	我吃葵花籽	I am eating sunflower seeds.
Llego al colegio corriendo.	我跑到学校	I arrive at school running.
El genio sale de la lámpara.	精灵从灯里出来	The genie comes out from the lamp.
A Sergio le gusta la magia.	塞赫尔喜欢魔术	Sergio likes magic.
Riego la maceta de geranios.	我在浇一盆天竺葵	I am watering the geranium flowerpot.
Ángela y Manolón son amigos.	安吉拉和马农龙是朋友	Ángela and Manolón are friends.



va ve vi vo vu

Va Ve Vi Vo Vu

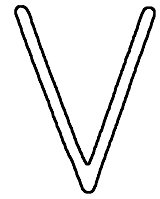

lluvia

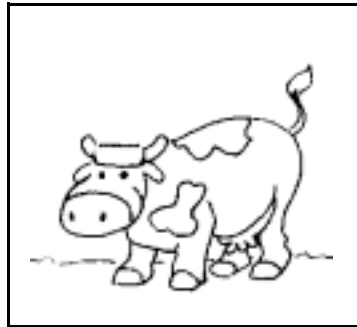

vaca



vela

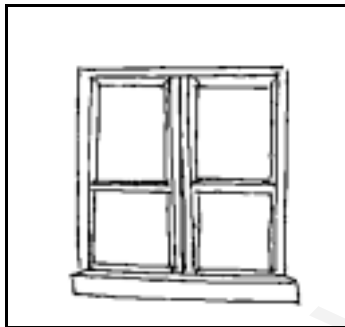

ventana

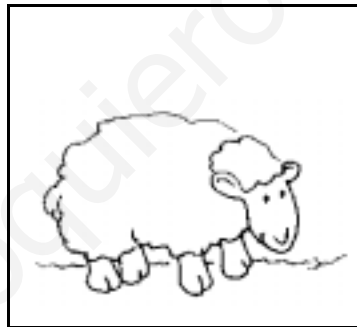

oveja

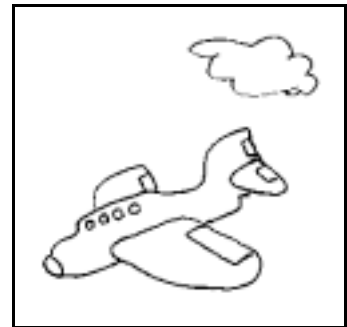

avión

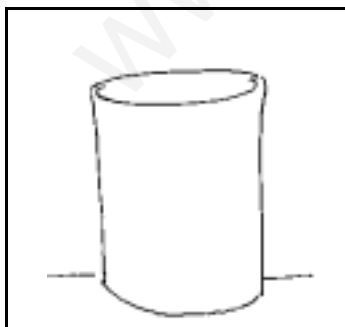

vaso

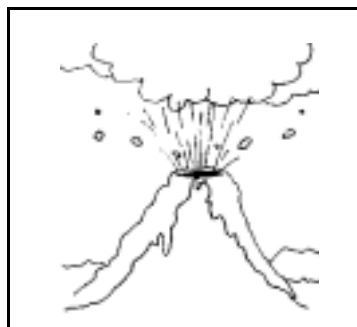

volcán

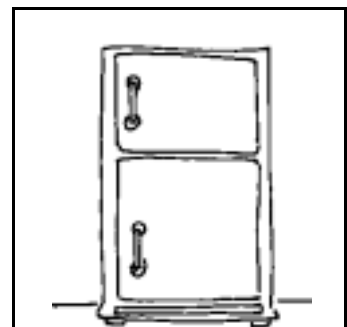

nevera

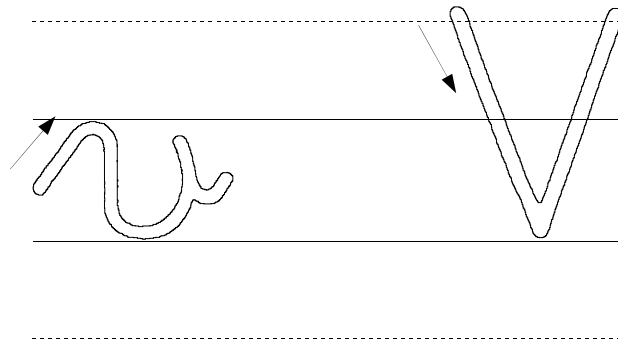

va ve vi ve vu
Va Ve Vi Ve Vu

oveja avión vaca volcán arispa
nevera vaso ventana vela ura
televisión verde Vicente valor

La oveja come hierba

Llueve en Sevilla

La vaca sale del establo

La vela la apaga el viento

Cierra bien la ventana

El avión sube a las nubes

Llena el vaso de leche

Este volcán me da miedo



Va Ve Vi Vo Vu

va ve vi vo vu

La botella de vino

La lluvia moja el paraguas

Vaca y oveja comen hierba

Pongo en la nevera la uva

Veo la televisión en el salón

El viento mueve la vela del yate

Llevo al perro de paseo

Uva y queso saben a beso



La oveja come hierba.

¿Qué come la oveja?

Veo en la televisión una película.

¿Qué veo en la televisión?

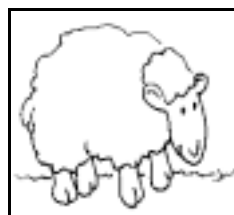
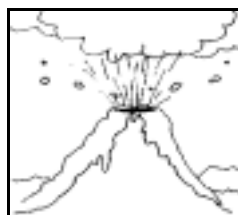
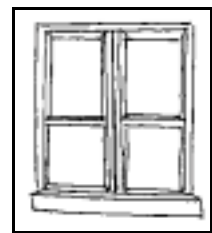
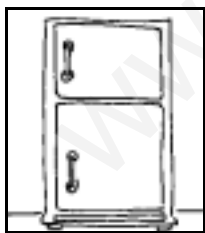
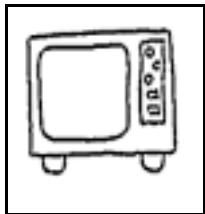

la uva
 el pavo
 la lluvia
 el televisor
 la nevera
 la vela
 la ventana
 el avión
 el volcán
 la oveja

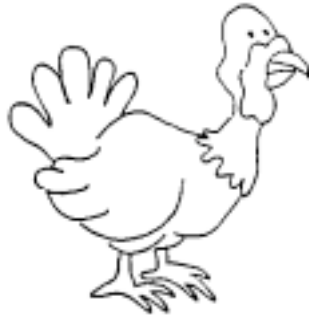

pavo



uva



lluvia



lavadora



avión

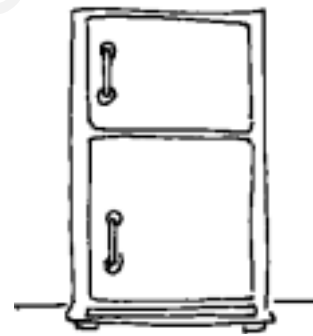

nevera



vaca



oveja



avispa

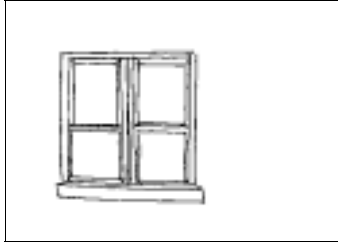

Pinto la ventana de verde

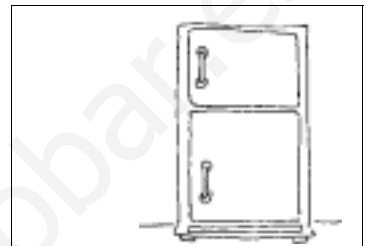

Meto un vaso en la nevera

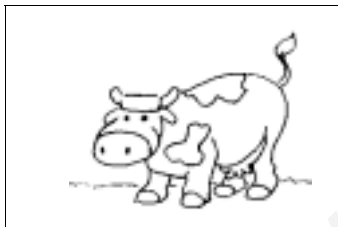

A la vaca le gusta la hierba

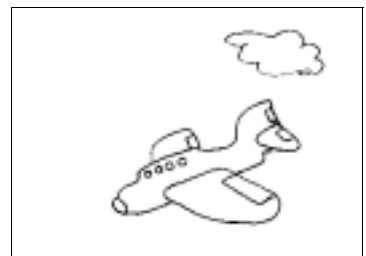

El avión sube hasta la nube



uno

muchos

el televisor	los televisores
el automóvil	los automóviles
el camión	los camion_____
el violín	los v_____
la Navidad	las
el avión	
el lápiz	
el tapón	
el volcán	

~~una~~ balcón vaca hierba nieve abeto
cubo lavadora sábado nueve

v
una

b



 <p>Leo...</p>	<p>Eva y Vicente</p>	
		
<p>Eva tiene seis años</p>	<p>Es vecina de Vicente</p>	<p>Los dos juegan al parchis en casa de Vicente</p>
		
<p>¿Qué hay en la ventana? ¡Qué susto!</p>	<p>Eva es muy valiente</p>	<p>No te asustes, Vicente, es Lulú.</p>

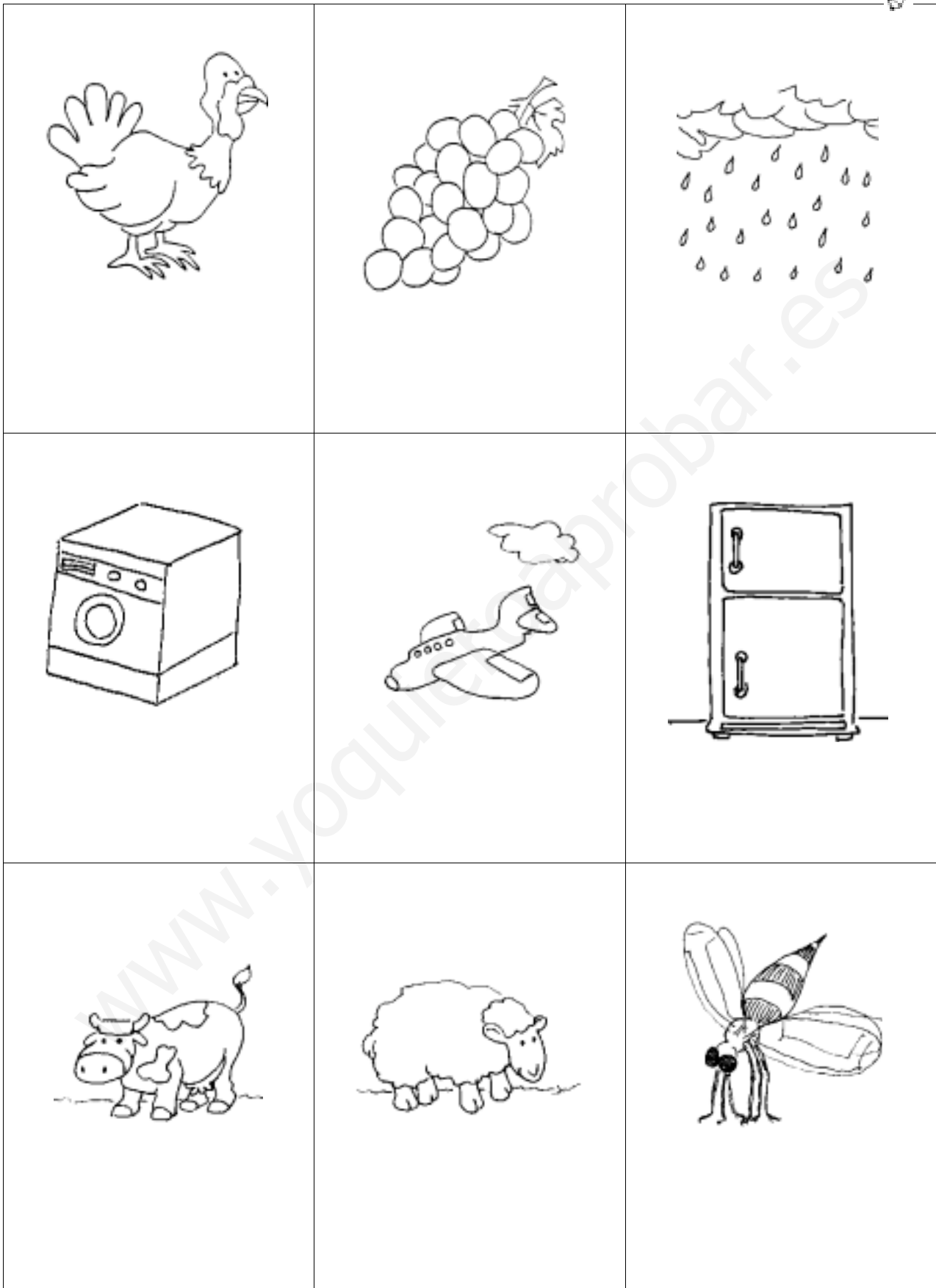



Eva tiene un



Como



,



y



Bebó un



de



Apago la



con un



La



y

la



comen hierba



La botella de vino
La lluvia moja el paraguas
Vaca y oveja comen hierba
Pongo en la nevera la uva
Veo la televisión en el salón
El viento mueve la vela del yate
Llevo al paso de paseo
Uva y queso saben a beso



Handwriting practice lines with a watermark: www.yoquieroaprobar.es



Tema 28	第二十八课	Unit 28
Eva y Vicente.	埃娃和比森特。	Eva and Vicente.
Eva tiene siete años.	埃娃有七岁了。	Eva is seven years old.
Es vecina de Vicente.	是比森特的邻居。	She is a neighbor of Vicente.
Los dos juegan al parchís en casa de Vicente.	他们两个在比森特的家玩帕	They both are playing parcheesi at Vicente's house.
¿Qué hay en la ventana? ¡Qué susto!	窗上有什么？吓我一跳！	What is at the window? What a fright!
Eva es muy valiente.	埃娃很勇敢。	Eva is very brave.
No te asustes, Vicente, es Lulú.	别害怕，比森特，是露露。	Don't be frightened, Vicente, it is Lulú.
La botella de vino.	葡萄酒的瓶子。	The bottle of wine.
La lluvia moja el paraguas.	雨把雨伞弄湿了。	The rain makes the umbrella wet.
Vaca y oveja comen hierba.	牛和绵羊吃草。	The cow and the sheep eat grass.
Pongo en la nevera la uva.	我把葡萄放在冰箱里。	I am putting the grape in the fridge.
Veo la televisión en el salón.	我在客厅里看电视。	I am watching TV in the living room.
El viento mueve la vela del yate.	风吹动游艇的帆。	The wind is moving the sail of the yacht.
Llevo al pavo de paseo.	我带着火鸡散步。	I am taking the turkey for a walk.
Uva y queso saben a beso.	葡萄和奶酪非常好吃	Grapes and cheese taste like a kiss.



xa xe xi xo xu
Xa Xe Xi Xo Xu

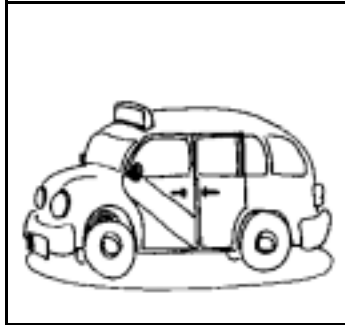
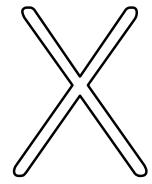

taxi

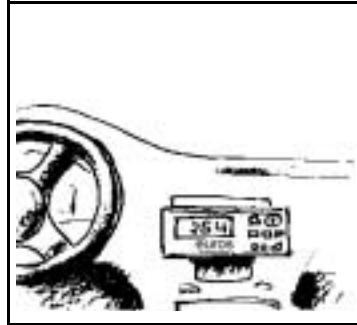

taxímetro



taxista

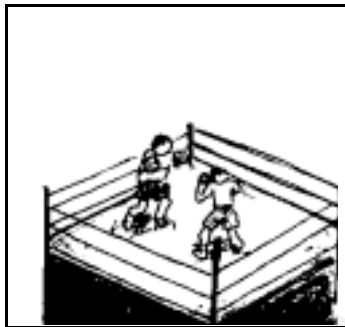

boxeo

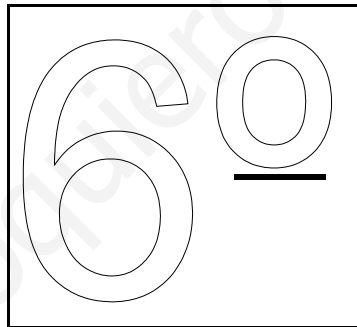

sesenta



Máximo



excavadora



saxofón



Félix

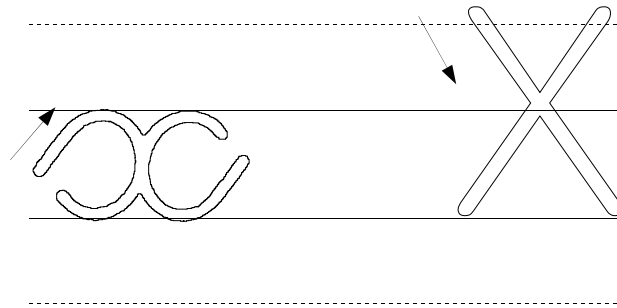

cc cc cc cc cc
 cc cc cc cc cc
 X X X X X

celébrano excavadora Máximo
 Félix taxi becas taxista teatro
 teatro taxímetro excursión
 próximo exposición

Máximo es taxista
 Vive en el sexto piso
 Vamos de excursión al monte
 La excavadora mueve la tierra
 Tece el sacofón en el teatro
 Félix escribe un teatro



Xa Xe Xi Xe Xu

ca ce ci ce cu

El taci de Máximo

Félica va de excursión

La excavadora va muy lenta

Toco el saxo y el teléfono

Subo hasta el sexto piso

Escribo un texto con el lápiz

Me gusta oír el teléfono

Veo una exposición de fotografías



Máximo es taxista.

¿Qué es Máximo?

El taxímetro marca tres euros.

¿Qué marca el taxímetro?



el texto
 el taxímetro
 el boxeo
 la excavadora
 el taxi
 Félix
 el xilófono
 el saxofón
 el sexto
 Máximo

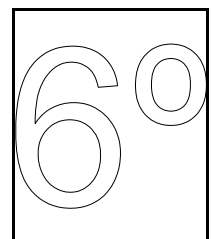
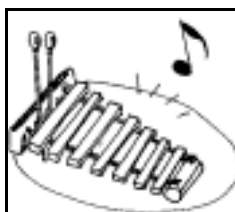
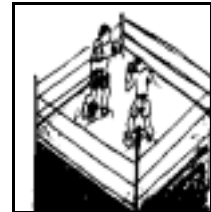



lecto

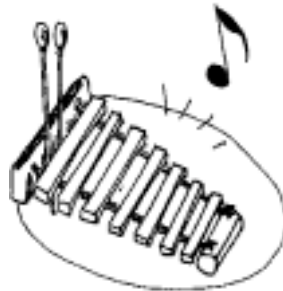

xilófono



taxi



Máximo



saxofón

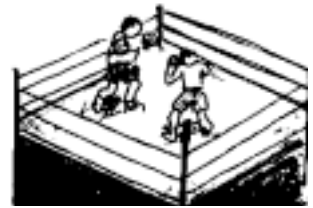

boxeo



tacómetro



Félicia

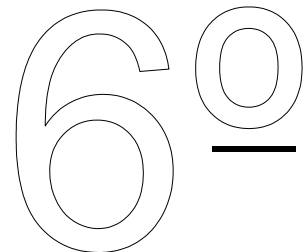

sesto

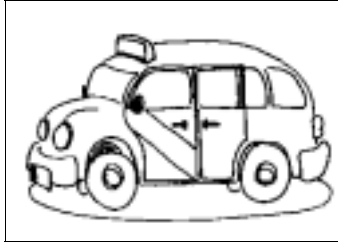

Llamo al taxi por teléfono

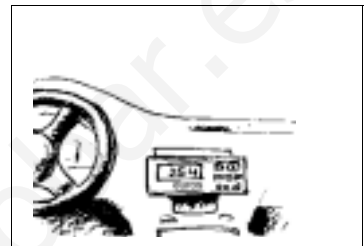

El taxímetro marca el dinero



Félix vive en un sexto piso

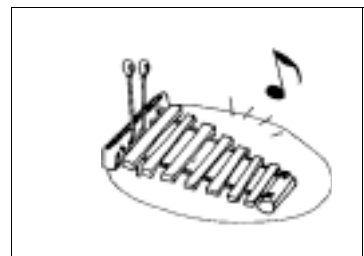

Mamá regala un xilófono a Félix



 <p>Leo...</p>	<p>Félix y su mamá</p>	
		
<p>Éstos son Félix y su mamá</p>	<p>Van de tiendas</p>	<p>Mamá le regala un xilófono</p>
		
<p>y una excavadora de juguete</p>	<p>¡Cuántos paquetes!</p>	<p>¡Taxi! ¡Taxi! por favor.</p>

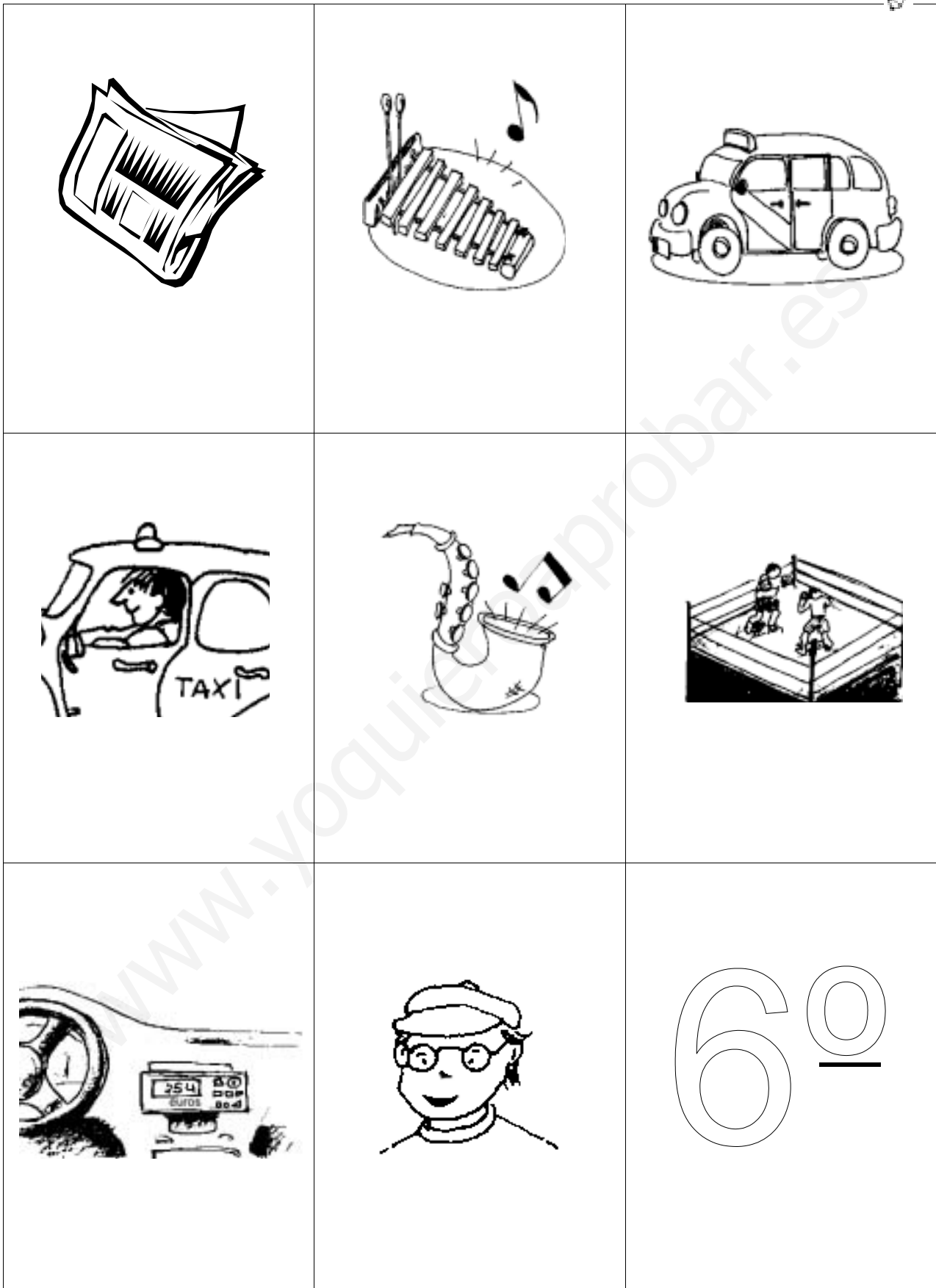



Yi tiene una



Máximo tiene un



blanco

Toco el



y el



Escribo el



con mi



Subo al 6^o piso



MÁXIMO, EL TAXISTA



Máximo es taxista.

Máximo tiene un taxi de color blanco.

Lleva a los pasajeros de excursión.

El jueves llevó a un pasajero a ver una exposición de textos antiguos.

Contesta

¿Qué es Máximo? _____

¿De qué color es su taxi? _____

¿Dónde lleva a los pasajeros? _____

¿Dónde fue el jueves? _____

~~bo~~so mayo excavadora yate saxofón
 texto yema taxi yo yuca

o
boooo

y



El taxi de Máximo
Félix va de excursión
La excavadora va muy lenta
Toco el saxo y el xilófono
Subo hasta el sexto piso
Escribo un texto con el lápiz
Me gusta oír el xilófono
Veo una exposición de fotografías



Handwriting practice lines with a watermark: www.yoquieroaprobar.es



Tema 29	第二十九课	Unit 29
Félix y su mamá.	Felix 和他的妈妈。	Felix and his mother.
Estos son Félix y su mamá.	这是Felix和他的妈妈。	These are Félix and his mother.
Van de tiendas.	他们去商店。	They are going shopping.
Mamá le regala un xilófono	妈妈送给他一架木琴。	Mum has given him a xylophone as a gift.
Y una excavadora de juguete.	和一台玩具掘土机。	She is giving him a toy excavator too.
¡Cuántos paquetes!	这么多合子!	So many packets they have!
¡Taxi! ¡Taxi! Por favor...	出租车！出租车！请帮帮忙...	Taxi! Taxi! Please!
...		
Máximo es taxista.	Maximo是出租车司机。	Máximo is a taxi driver
Máximo tiene un taxi de color blanco.	Maximo有一辆白色的出租车。	Máximo has a white taxi
Lleva a los pasajeros de excursión.	他带两位乘客出游。	He takes the passengers on excursion.
El jueves llevó a un pasajero a ver una exposición de textos antiguos.	星期四他带一个乘客参观一个古书展览。	He took a passenger to see an ancient text exhibition last Thursday.
		
El taxi de Máximo.	Maximo的出租车。	Máximo's taxi
Félix va de excursión.	Felix去游玩。	Félix is going on excursion.
La excavadora va muy lenta.	掘土机很慢。	The excavator is very slow.
Toco el saxo y el xilófono.	我吹萨克斯管和弹木琴。	I play the sax and the xylophone.
Subo hasta el sexto piso.	我上到六楼。	I am going up to the sixth floor.
Escribo un texto con el lápiz.	我用铅笔写课文。	I am writing a text with the pencil.
Me gusta oír el xilófono.	我喜欢听木琴。	I like listening to the xylophone.
Veo una exposición de fotografías.	我看一个照片展览。	I am seeing a photograph exhibition.



ka ke ki ko ku
Ka Ke Ki Ko Ku

k K

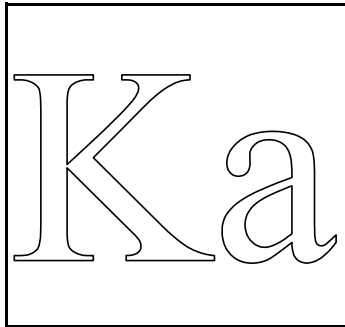

Ka



kilo



karate



karaoke



anorak

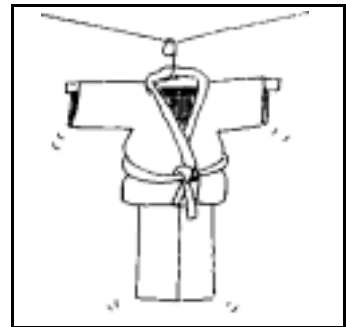

kimono



kilómetro



koala



karateca

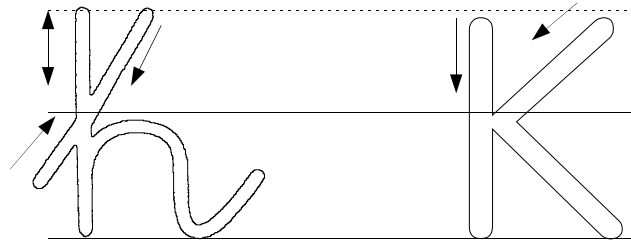

ka ke ki ko ku
ah eh ih oh uh
Ka Ke Ki Ko Ku
hilo karate amarak hoala ka
karashe hoala kimono kiesco
kilómetro karatesca
Cecilia es karatesca
Compro medio kilo de queso
Canto en un karashe
El hoala vive en los árboles
Tengo un amarak rojo y azul
La playa tiene seis kilómetros.
Pido un libro en el kiesco.



Ka Ke Ki Ko Ku

ka ke ki ko ku

Compro dos kilos de tomates

Todas las tardes voy al karate

Hu canta en el karaoke

El koala vive en Australia

Me pongo el amorah amarillo

Emi es una buena karateca

Llego hasta el kilómetro seis

El taxi lleva la letra ka



Cecilia va al karate.

¿Dónde va Cecilia?

El anorak es de color amarillo.

¿De qué color es el anorak?

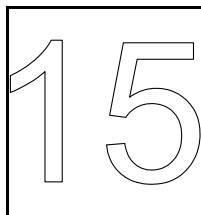

el quince
 el hoala
 el kilómetro
 el kilo
 el karaoke
 el karate
 el anorak
 la karateca
 la ka
 el kimono

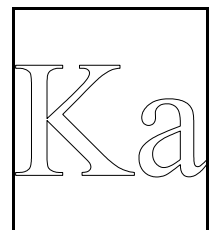
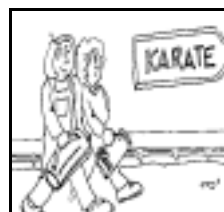
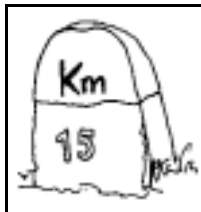



koala



kilometro



kilo



karaoke



karateca



amorak

Ka

ka



karate



kimono



Me pongo el anorak amarillo



Pido un kilo de queso



Cecilia es una buena karateca



El koala vive en los árboles

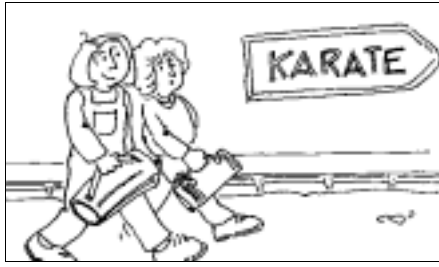

Cecilia y Nadia van al karate.

Llevan su kimono en una bolsa de lona.

Contesta

¿Dónde van Cecilia y Nadia? _____

¿Qué llevan en la bolsa? _____

¿Dónde van Cecilia y Nadia? _____

~~kilo~~ queso karate esquimal anorak esquí
karashe koala quitasol quince karateca
ka moqueta kilómetro mosquito Quique

k
kilo

que - qui



Leo...

Las tardes de Cecilia,
Nadia y Hasan



Cecilia y Nadia van todas las tardes a karate.

Siempre van juntas, son muy amigas.



Cecilia practica todos los días.









Cuando termina, se asea, y guarda su kimono en la bolsa.



Hasan trabaja en una tienda de comestibles.

Despacha medio kilo de queso manchego.



		
		
<p data-bbox="225 1563 517 1742">Ka</p>		



Nadia tiene un

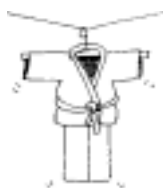

Cecilia es una buena



Compro medio  de queso

Canto en el  del bar

Me pongo el  amarillo



Compro dos kilos de tomates
Todas las tardes voy al karate
Hua canta en el karaoke
El koala vive en Australia
Me pongo el anorak amarillo
Cecilia es una buena karateca
Llego hasta el kilómetro seis
El taxi lleva la letra ka



Handwriting practice area with multiple sets of horizontal lines (solid top and bottom lines, dashed middle line) for writing practice.



Tema 30	第三十课	Unit 30
Celia y Nadia van al karate.	Celia和Nadia去练空手道。	Cecilia and Nadia are going to karate.
Llevan su kimono en una bolsa de lona.	他们把和服装在一个毛线袋里。	They take their kimonos in a canvas bag.
...		
Las tardes de Cecilia, Nadia y Hasan.	Cecilia、Nadia和Hasan的下午。	Cecilia, Nadia and Hasan's afternoons.
Cecilia y Nadia van todas las tardes a karate.	Celia和Nadia每天下午都去练空手道。	Cecilia and Nadia go to karate every afternoon.
Siempre van juntas, son muy amigas.	她们总是一起去，她们是好朋友。	They always go together, they are good friends.
Cecilia practica todos los días.	Celia每天都练习。	Cecilia practices everyday.
Cuando termina, se asea, y guarda su kimono en la bolsa.	训练结束后，她梳洗并把和服收到包里。	When she has finished, she washes herself and packs her kimono in the bag.
Hasan trabaja en una tienda de comestibles.	Hasan在一个食品店里工作。	Hasan works in a grocer's shop.
Despacha medio kilo de queso manchego.	他出售半公斤的manchego奶酪。	He is selling half a kilo of 'Manchego' cheese.
 Compró dos kilos de tomates.	我买两公斤西红柿。	I am buying two kilos of tomatoes.
Todas las tarde voy al karate.	每天下午我都去练空手道。	I go to karate every afternoon.
Hua canta en el karaoke.	华唱卡拉OK。	Hua is singing karaoke.
El koala vive en Australia.	树袋熊住在澳大利亚。	Koalas live in Australia.
Me pongo el anorak amarillo.	我穿上黄色的防雨外套。	I am putting the yellow anorak on.
Cecilia es una buena karateca.	Cecilia是一个优秀的空手道运动员。	Cecilia is a good karateist.
Llego hasta el kilómetro seis.	我达到六公里。	I arrive until the sixth kilometer.
El taxi lleva la letra ka.	出租车上字母K。	The taxi has the letter 'K' on it.



gie gii

giü Giü



pingüino

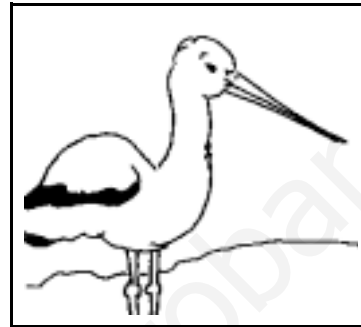

cigüeña



piragüista

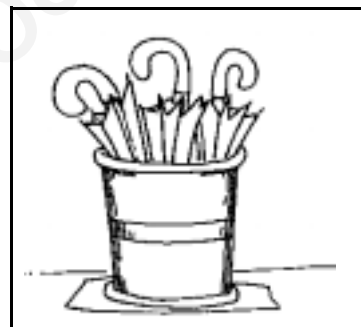

paragüero



pedigüeño



zarigüeya



gü Gü

güe güi

Güe Güi

pingüino cigüeña paraguero

piragüista agüita cigüeñal

pedigüeño zarigüeyá

La cigüeña es un ave

El pingüino es un ave

La cigüeña vuela

El pingüino nada, no vuela

Dame agüita fresquita

Los pingüinos y los esquimales

El paraguero está mojado

En la tierra hay un nido de

cigüeña



Gua Gue Güi Guo

qua que güi quo

La zarigüeya es pequeña

El nido de la cigüeña

El paraguero está mojado

Los pingüinos nadan

El pediguero lleva chaqueta

En el campanario hay
una cigüeña pequeña.



El pingüino vive en el
polo.





En el paraguero hay seis paraguas.

¿Cuántos paraguas hay?

La cigüeña está en el campanario.

¿Dónde está la cigüeña?

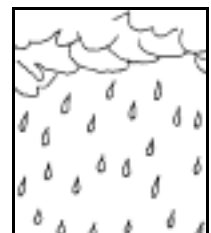
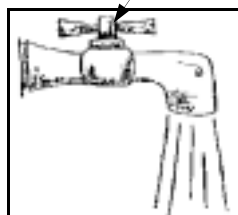
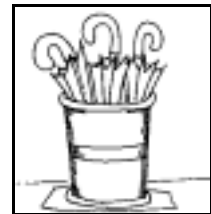
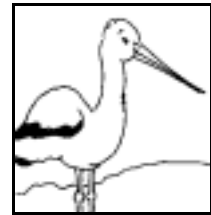

el pingüino
 la cigüeña
 el paraguero
 la zarigüeya
 el pedreguero
 el paraguas
 la lluvia
 el piragüista
 el anorak
 el aguata



pinguino

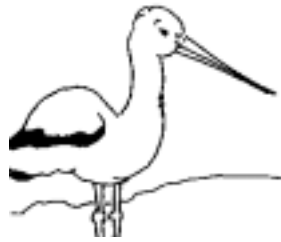

cigüeña



paragueros



carigüera



piragüista

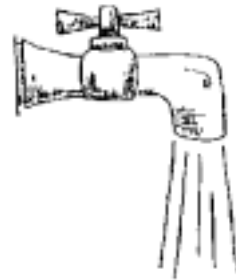

agüita



paraguas



lluvia



amorak



El anorak me guarda de la lluvia

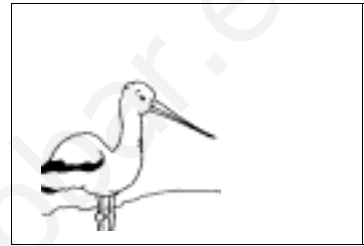

Las cigüeñas tienen el pico largo



Los pingüinos son nadadores

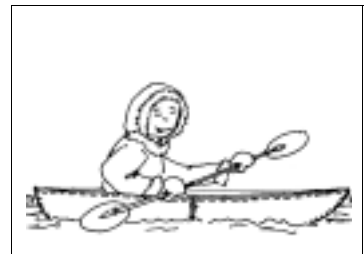

El esquimal es piragüista



DIEGO Y SU GATO



Diego asea a su _____.

Lo mete en una palangana con _____
caliente.

Usa _____ de goma.

El gato se _____ un poco.

Salpica muchas _____ de agua.

Lo seca con una _____.

El gato queda muy _____.

agua guantes gato asusta
toalla gotas limpio



números	
uno	1
dos	2
tres	3
cuatro	4
cinco	5
seis	6
siete	7
ocho	8
nueve	9

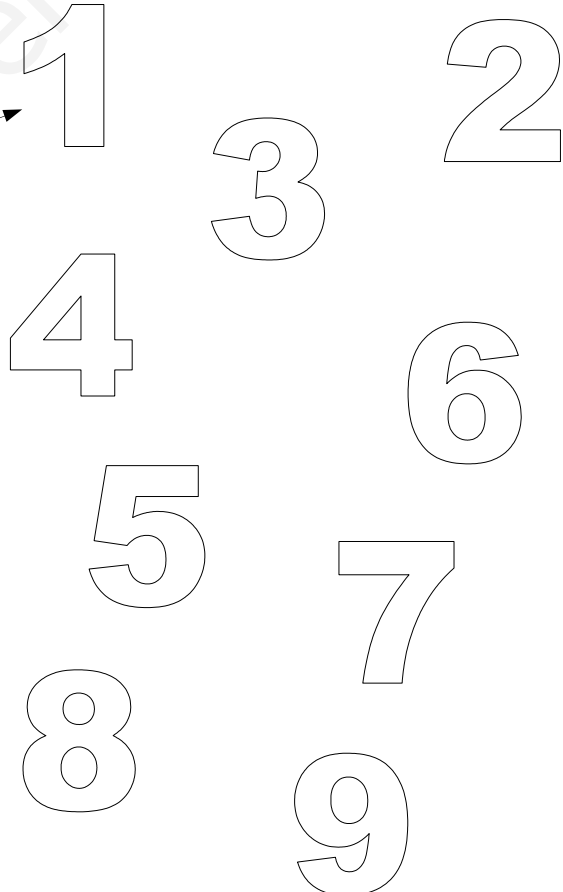



Leo...

Mi visita al zoológico



La cigüeña tiene un nido en el campanario.

Cuando está de pie sólo se le ve una pata.



Los pingüinos están en el hielo.

Todos pasean por el agua helada.



Empieza a llover y tengo que coger el paraguas.

Llego a casa mojado.

Pongo el paraguas en el paraguiero.

El paraguiero tiene seis paraguas





Completa con ga que qui go gu güe güi

Mi ___ l come ___ santes.

Die ___ pinta un moni ___ te.

El ___ sano come lechu ___ .

Adela metió un ___ l.

Papá ___ sa patatas.

La ci ___ ña tiene un nido.

Me ___ stan las ___ ndas.

Me ___ stan los pin ___ nos.

Luis es mi ami ___ .

Nadia tiene un ___ to.

Dame el al ___ dón.

Meto el



en el



El



es nadador

Hay una

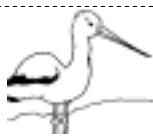

en la

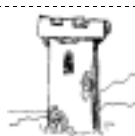



La zarigüeya es suave
El nido de la cigüeña
El paraguero está mojado
Los pingüinos nadan
El pedreguero lleva chaqueta
El pingüino vive en el polo
En el campanario hay una cigüeña pequeña.
Empieza a llover y cojo el paraguas



Handwriting practice lines with a watermark: www.yoquieroaprobar.es



Tema 31	第三十一课	Unit 31
Mi visita al zoológico.	我参观动物园。	My trip to the zoo.
La cigüeña tiene un nido en el campanario.	白鹤在钟楼上有一个窝。	The stork has a nest on the bell tower.
Cuando está de pie sólo se le ve una pata.	当它站立时人们只能看到它的一只爪子。	Only one of its legs is seen when it is standing.
Los pingüinos están en el hielo.	企鹅在冰上。	Penguins are on the ice.
Todos pasean por el agua helada.	所有的都在冰冷的水里散步。	Everybody is walking on the frozen water.
Empieza a llover y tengo que coger el paraguas.	开始下雨了，我得拿伞。	It is starting to rain and I have to pick up the umbrella.
Llego a casa mojado.	回到家是我已被淋湿。	I am arriving wet at home.
Pongo el paraguas en el paragüero.	我把伞放在装伞的桶里。	I am putting the umbrella in the umbrella stand.
El paragüero tiene seis paraguas.	伞桶里有六把伞。	There are six umbrellas in the umbrella stand.
		
La zarigüeya es suave.	负鼠很柔软。	The opossum is soft.
El nido de la cigüeña.	白鹤的窝。	The nest of the stork.
El paragüero está mojado.	伞桶湿了。	The umbrella stand is wet.
Los pingüinos nadan.	企鹅们游泳。	Penguins swim.
El pedigüeño lleva chaqueta.	喜欢讨要的人穿着夹克衫。	The beggar is wearing a jacket.
El pingüino vive en el polo.	企鹅住在极地。	The penguin lives in the pole.
En el campanario hay una cigüeña pequeña.	钟楼里有一只小白鹤	There is a little stork on the bell tower.
Empieza a llover y cojo el paraguas.	开始下雨了，我拿起雨伞。	It is starting to rain and I am picking up the umbrella.



wa we wi wo wu

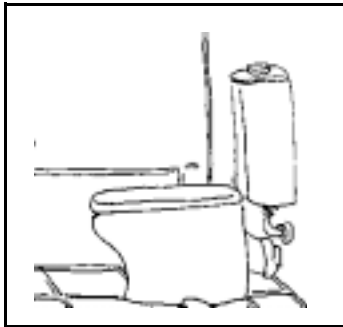
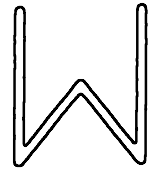

wáter

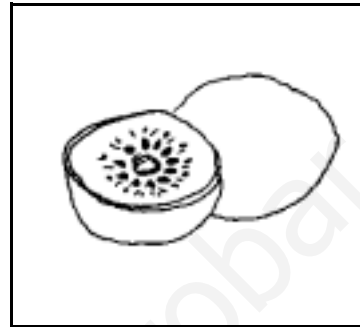

kiwi



waterpolo



western



cow-boy



windsurf

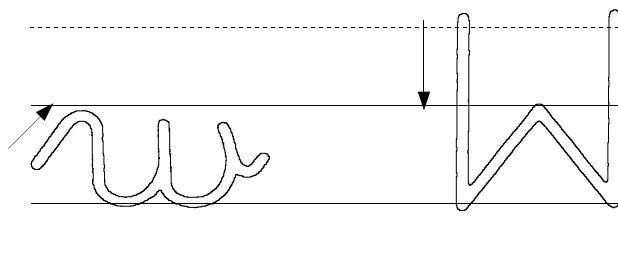

wa we wi wo wu
wa we wi wo wu

wáter kiwi wapiti cow-boy
windsurf western waterpolo

El windsurf es un deporte
Hoy como kiwi de merienda
El waterpolo se juega en el
agua

El cow-boy monta a caballo
Ayer vi un western en la tele
El wapiti es un ciervo grande
El wáter es el cuarto de baño
El kiwi también es un ave



Ma Me Mi Mo Mu

va ve vi vo vu

El waterpolo es un deporte

El wapití es un ciervo grande

El W. C. es el wáter

El cow-boy cuida a las vacas

Pido medio kilo de kirvis

En la playa de Tarifa se
puede hacer windsurf.



La bañera está en el
wáter.

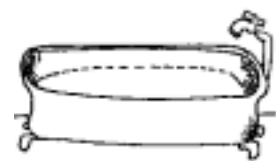



Juego a waterpolo en la piscina.

¿A qué juego en la piscina?

Me como dos kiwis en la merienda.

¿Qué meriendos?

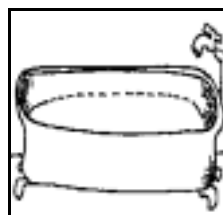
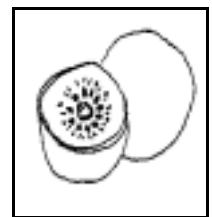
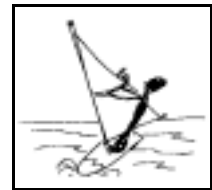
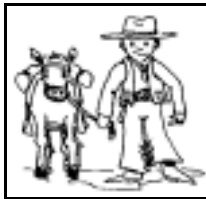

el cow-boy
 el windsurf
 la torre
 el wáter
 el western
 la ola
 el kiwi
 el waterpolo
 el pingüino
 la bañera



hirvi

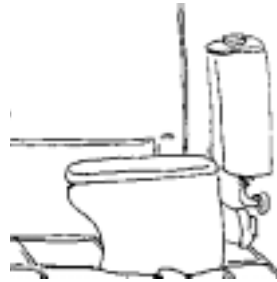

wáter



cow-boy



waterpolo



windsurf



ola



bañera



torre



western



Pepe va al wáter



Él cow-boy cuida las vacas



El waterpolo es un deporte

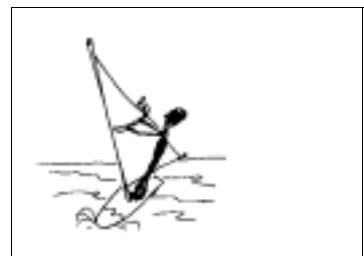

Tomás hace windsurf

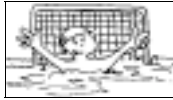

MARTA JUEGA AL WATERPOLO



A Marta le _____ nadar.
 Va todos los días a la _____.
 Tiene un _____ azul.
 Se pone un _____ en la cabeza para no
 mojarse el _____.
 Cuando termina se seca con una _____.
 Se pone un _____ de color blanco.
 Su mamá la _____ para ir a casa.

gusta bañador gorro piscina espera
 toalla albornoz pelo

números	
nueve	9
ocho	8
siete	7
seis	6
cinco	5
cuatro	4
tres	3
dos	2
uno	1

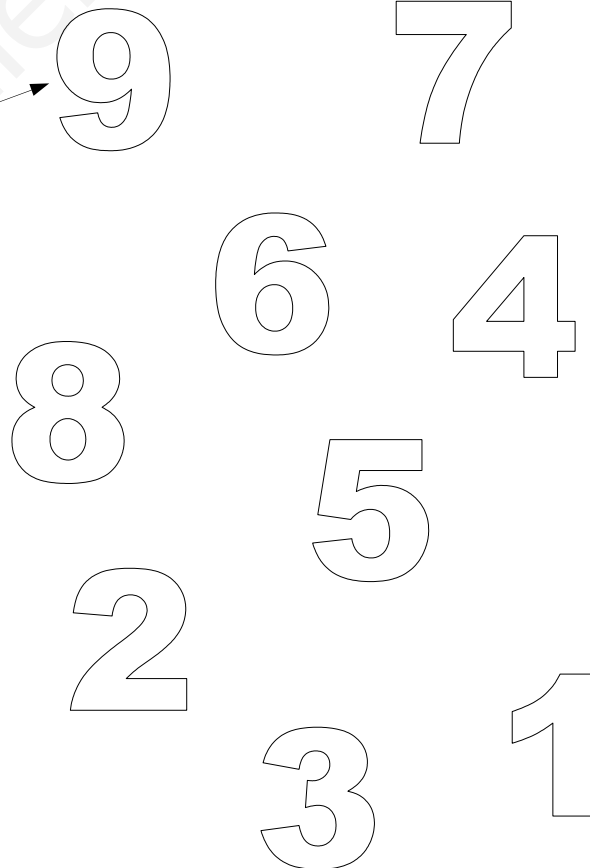



Leo...

W. C. El wáter.
En el cuarto de baño



En el cuarto de baño hay una
bañera grande.

La lleno de agua caliente para
bañarme.



Algunas veces es mejor una
buena ducha.

Me quita mejor el sudor.



Pepe quiere hacer pipí.

No es bueno aguantar tanto.

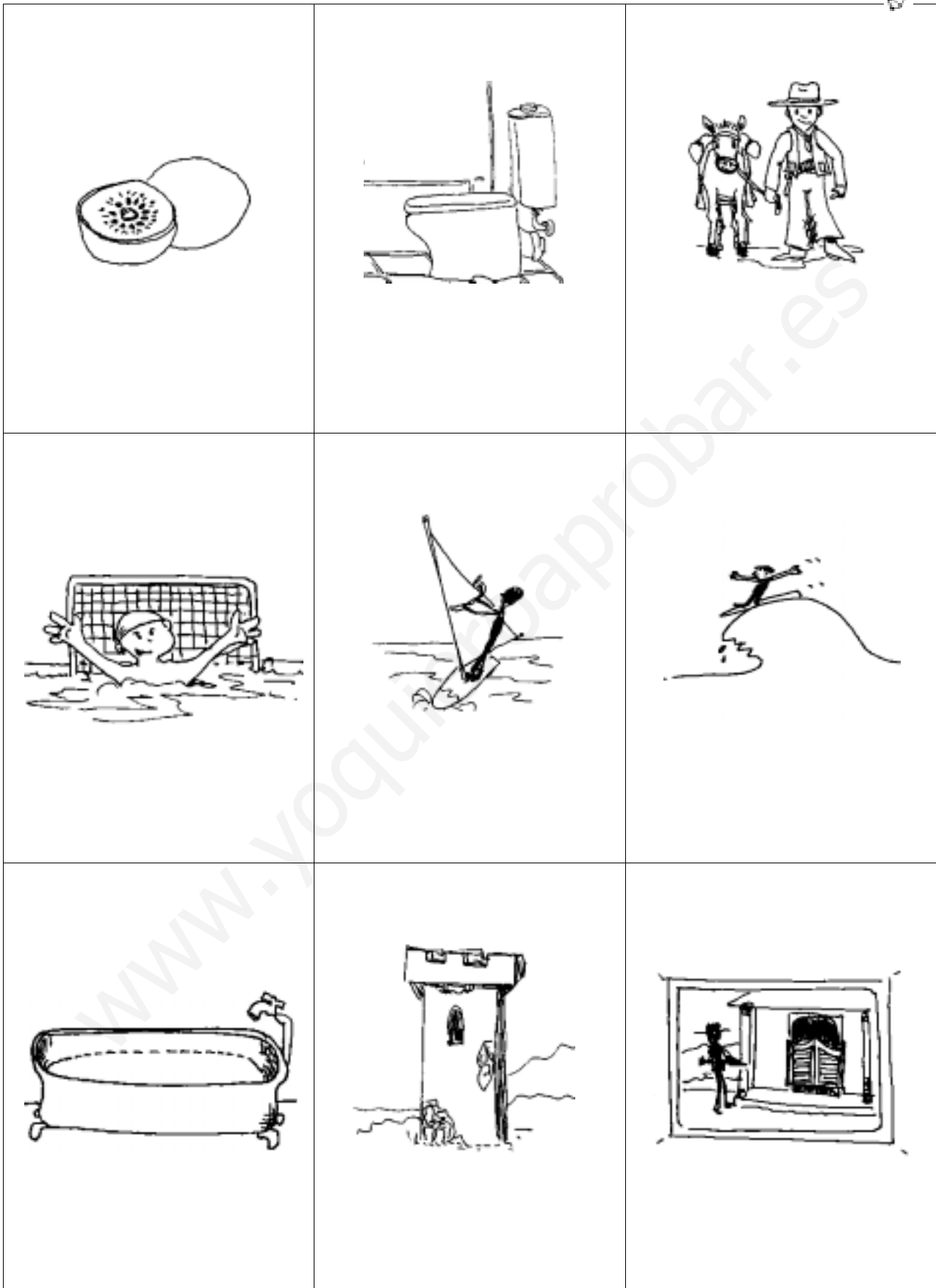



Completa con za zo zu ez iz uz

Loren__ se __mpó todo el pastel.

Los __patos son a__les.

Los __ecos son __patos de madera.

La a__tea está encima de la tierra__.

La gata ca__ cinco ratones.

El __mo está en el vaso.

Tu láp__ no pinta bien.

La perd__ empe__ a correr.

Mi muñeca tiene un la__ a__l.

El gato de Tamara se llama Micif__.

El lu__ sale del agua.

El



cuida a las



El



es un deporte

Hay una



en el

W.C.



El waterpolo es un deporte
El wapiti es un ciervo grande
El W. C. es el wáter
El cow-boy cuida a las vacas
Pido medio kilo de kiwis
La bañera está en el wáter.
En la playa de Tarifa se puede hacer
windsurf.



Handwriting practice area with multiple sets of horizontal lines (solid top and bottom lines, dashed middle line) for writing practice. Two small circles are present on the first two sets of lines.



Tema 32	第三十二课	Unit 32
W.C. El wáter.	厕所	W.C. The toilet.
En el cuarto de baño.	浴室	In the bathroom.
En el cuarto de baño hay una bañera grande.	浴室里有一个大浴缸。	There is a big bath in the bathroom.
La lleno de agua caliente para bañarme.	我把浴缸灌满水好洗澡。	I fill it with hot water in order to take a bath.
Algunas veces es mejor una buena ducha.	有些时候最好是淋浴。	Sometimes, a nice shower is better.
Me quita mejor el sudor.	可以把汗冲掉。	It is better to get the sweat out.
Pepe quiere hacer pipí.	Pepe想小便。	Pepe needs a wee.
No es bueno aguantar tanto.	憋太久不好。	Holding so long is not good.



El waterpolo es un deporte.	水球是一种运动。	The water polo is a sport.
El wapití es un ciervo grande.	马鹿是一种很大的鹿。	The wapiti is big deer.
El W.C. es el wáter.	WC是厕所。	The W.C. is the toilet.
El cow-boy cuida las vacas.	牛仔照管牛群。	The cow-boy takes care of cows.
Pido medio kilo de kiwis.	我要半公斤猕猴桃。	I am asking for half a kilo of kiwifruits.
La bañera está en el wáter.	浴缸在卫生间。	The bath is in the bathroom.
En la playa de Tarifa se puede hacer wind-surf.	在Tarifa海滩可以冲浪。	You can play windsurfing on Tarifa beach.

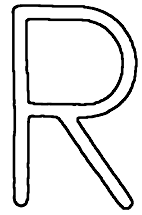
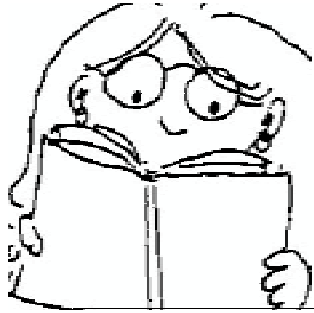

anorak

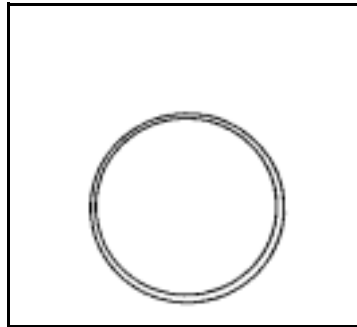

aro

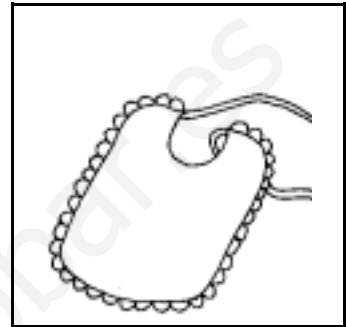

babero

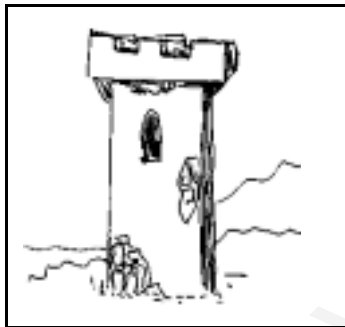

torre

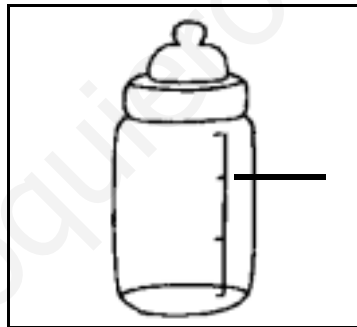

liberón

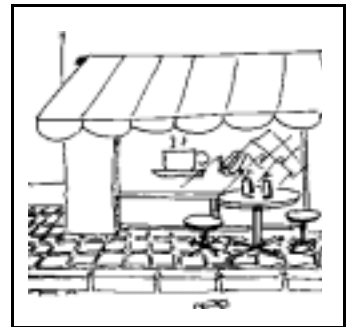

cafetería



caracol

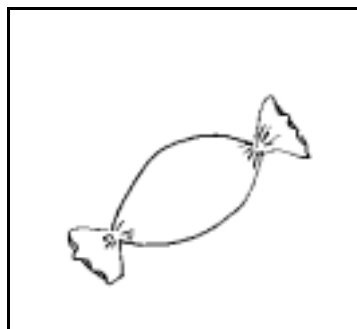

caramelo

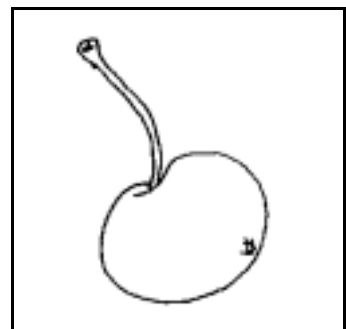

cereza



a b c d e f g h i j k l m n



ñ o p q **r** s t u v w x y z

LECTURA

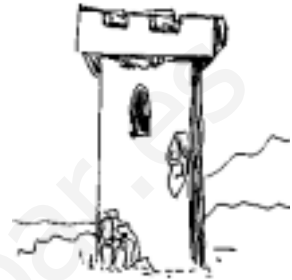

El pirata Roque tiene un perro marrón que se llama Caro.
A Caro le gustan los macarrones con tomate.

Roque tiene un arca llena de monedas de oro. Cuando llevó el arca a la torre, se resbaló en el barro y todas las monedas de oro rodaron cuesta abajo.

RESPONDER

1. ¿Cómo se llama el pirata?

El pirata se llama

2. ¿Cómo se llama el perro del pirata?

3. ¿Qué le gusta comer al perro del pirata?

4. ¿De qué estaba lleno el arca del pirata?

5. ¿Dónde se resbaló el pirata?



UNE CON FLECHAS

Berta
 el cenicero
 la cara
 la ciruela
 duro
 la excavadora
 el geranio
 el girasol
 el gorro
 la guitarra
 el jersey
 la jirafa
 la torre
 la zanahoria
 el yogur



CURRO TOCA LA GUITARRA



A Curro le gusta tocar la _____.

Toca y toca sin _____.

Toca por la mañana, toca por la _____,
toca por la noche.

Siempre lleva un _____ de color _____.

Cuando descansa de _____, guarda la
guitarra en el _____.

guitarra parar gorro tarde tocar armario
rojo

números	
diez	10
once	11
doce	12
trece	13
catorce	14
quince	15
dieciséis	16
diecisiete	17
dieciocho	18
diecinueve	19

10 12
11 17
13 18
14 15
16 19



El pirata Roque tiene un perro marrón que se llama Caro.

A Caro le gustan los macarrones con tomate.



Roque tiene un arca llena de monedas de oro. Cuando llevó el arca a la torre, se resbaló en el barro y todas las monedas de oro rodaron cuesta abajo.

Handwriting practice area with multiple sets of horizontal lines (solid top and bottom lines, dashed middle line) for writing.



Tema 33

- El pirata Roque tiene un perro marrón que se llama Caro.
 - Caro le gustan los macarrones con tomate.
 - Roque tiene un arca llena de monedas de oro. Cuando llevó el arca a la torre, se resbaló en el barro y todas las monedas de oro rodaron cuesta abajo.
-

第三十三课

- 海盗Roque有一条棕色的狗叫Caro.
 - Caro喜欢通心粉加番茄。
 - Roque有一个装满金币的箱子。他把箱子拿上塔楼时，踩到烂泥滑倒，所有的金币都滚到地上。
-

Unit 33

- Roque the pirate has a brown dog called Caro.
 - Caro likes macaroni with tomato sauce.
 - Roque has a chest full of golden coins. When he took the chest up to the tower, he slipped on the mud and all the golden coins rolled away down the slope.
-



Delante de (n) y (b) se escribe (m)

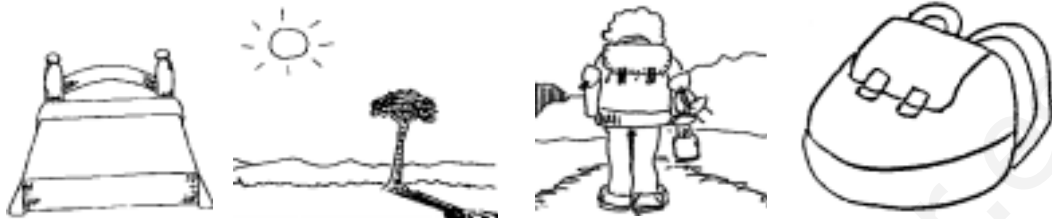

LECTURA

En septiembre empieza el colegio y mi amiga Amparo se prepara para ir de acampada.

Amparo dice que dormir ocho horas es empezar bien el día.

Mañana va al campo. No debe olvidar meter la lámpara y la tienda de campaña en la mochila.

RESPONDER

1. ¿Qué dice Amparo?

Que dormir.

2. ¿Cuántas horas duerme?

3. ¿Dónde va Amparo mañana?

4. ¿Qué mete en la mochila?

5. ¿Qué es lo que no debe olvidar Amparo?

6. ¿Cuándo empieza el colegio?



a b c d e f g h i j k l m n
 ñ o p q r s t u v w x y z



DE EXCURSIÓN

_____ salió de casa con su _____ llena.

Esperó al _____.

Cuando llegó al _____, sacó de la mochila la tienda de _____ y la montó.

Por la noche encendió la _____, se _____ de _____ y se puso a dormir.

Amparo campaña campo mochila lámpara
 ropa autobús cambió



Busca palabras...

A	U	T	O	B	U	S	K	L	H
U	D	L	A	M	P	A	R	A	N
M	I	T	D	Y	X	N	O	F	S
P	C	A	M	P	O	K	G	C	Z
Ñ	A	S	G	T	R	E	E	L	S
C	A	M	P	A	Ñ	A	C	H	O
B	S	R	I	A	M	P	A	R	O
N	L	G	D	C	T	U	V	B	S
L	N	M	O	C	H	I	L	A	G
L	K	J	U	T	E	S	C	N	A

—AMPARO—
 AUTOBÚS
 CAMPAÑA
 CAMPO
 LÁMPARA
 MOCHILA



Formo frases

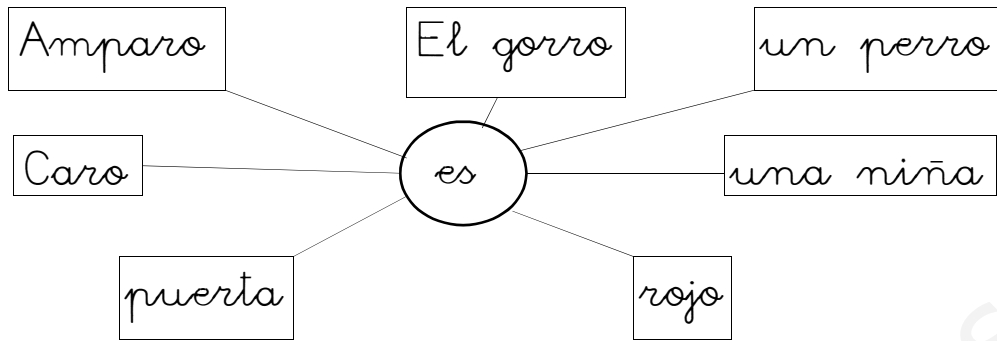

Amparo es una niña

números	
veinte	20
veintiuno	21
veintidós	22
veintitrés	23
veinticuatro	24
veinticinco	25
veintiséis	26
veintisiete	27
veintiocho	28
veintinueve	29

20 22
 21 27
 23 28
 24 25
 29 26



¿Qué hace Amparo?



Amparo...

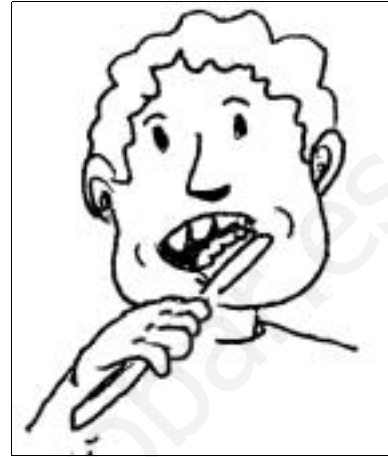

Amparo...





En septiembre empieza el colegio y mi amiga Amparo se prepara para ir de acampada.

Amparo dice que dormir ocho horas es empezar bien el día.



Mañana va al campo. No debe olvidar meter la lámpara y la tienda de campaña en la mochila.

Amparo salió de casa con su mochila llena. Esperó al autobús.

Cuando llegó al campo, sacó de la mochila la tienda de y la montó. Por la noche encendió la lámpara.

Handwriting practice area consisting of multiple sets of horizontal lines (top solid, middle dashed, bottom solid) for writing.



Tema 34

- En septiembre empieza el colegio y mi amiga Amparo se prepara para ir de acampada.
 - Amparo dice que dormir ocho horas es empezar bien el día.
 - Mañana va al campo. No debe olvidar meter la lámpara y la tienda de campaña en la mochila.
-

三十四课

- 九月学校开学，我的朋友Amparo准备去野营。
 - Amparo说八小时睡眠是一天好的开始。
 - ..明天去郊外。不要忘记把灯和帐篷放进包里。
-

Unit 34

- The School starts in September and my friend Amparo is getting ready to go camping.
 - Amparo says that sleeping eight hours means starting well the day.
 - He is going to the country tomorrow. He must not forget to put the camp and the tent into the backpack.
-



Pla, ple, pli, plo, plu.
 Pal, pel, pil, pol, pul.



LECTURA

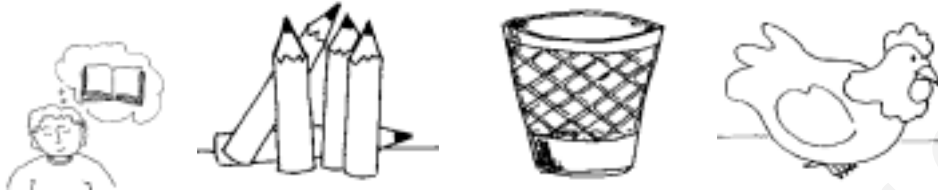

Yo leo en un pliego de papel. También dibujo con lápices de colores. Cuando me sale mal tiro el papel a la papelera.
 Tomo sopa del plato con una cuchara.
 Todos los pájaros tienen plumas.

RESPONDER

1. ¿Dónde leo?

.....

2. ¿Con qué dibujo?

.....

3. ¿Qué hago con el papel cuando me sale mal el dibujo?

.....

4. ¿Dónde está la sopa?

.....

5. ¿Con qué cojo la sopa?

.....

6. ¿Quiénes tienen plumas?

.....



a b c d e f g h i j k **l** m n
 ñ o **p** q r s t u v w x y z

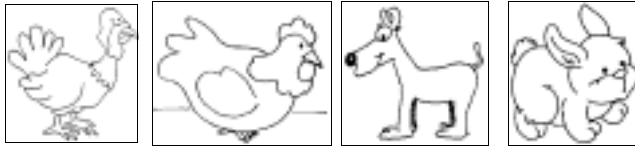

LOS ANIMALES

Los pavos, las _____ y las gallinas tienen plumas. Los patos también tienen _____.

Los _____, los conejos y los caballos tienen pelo. Los gatos también tienen _____.

Las _____ y los sapos no tienen pelos.

perros palomas plumas pelos ramas



Busca palabras...

Ñ	L	O	P	U	G	B	V	R	E
L	D	S	R	D	P	L	A	T	O
A	C	X	E	M	B	N	C	B	A
R	A	P	L	O	M	O	F	E	W
R	P	L	U	M	A	F	J	H	Ñ
U	G	D	C	J	M	Z	A	I	Y
O	P	G	F	P	L	I	E	G	O
G	F	E	I	L	F	S	S	E	P
R	D	P	A	P	E	L	E	R	A
C	T	D	S	Ñ	R	N	K	O	S

- ~~PLATO~~
- PLOMO
- PAPEL
- PLUMA
- PLIEGO
- PAPELERA



Formo frases

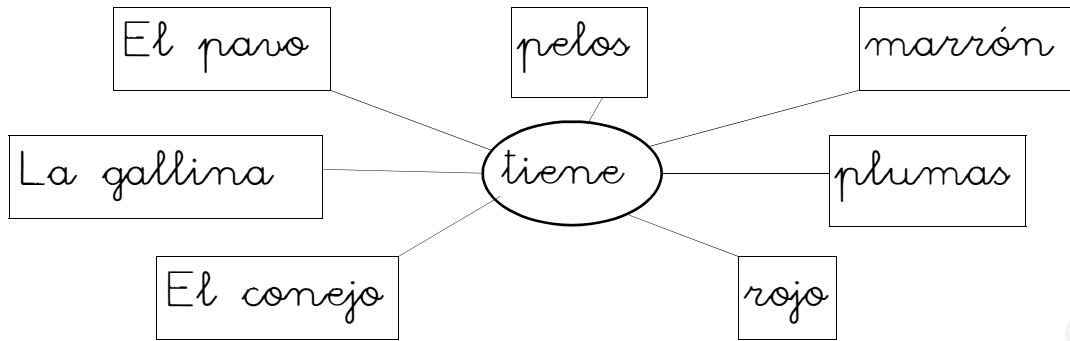

.....

.....

.....

.....

.....

.....

.....

.....

números	
treinta	30
treinta y uno	31
treinta y dos	32
treinta y tres	33
treinta y cuatro	34
treinta y cinco	35
treinta y seis	36
treinta y siete	37
treinta y ocho	38
treinta y nueve	39

30 32

31 37

39 38

34 25

33 36



Veo, veo...



Colegio, biblioteca, Ayuntamiento, parque, ambulancia, banderas, reloj, árboles, puente, fuente, ventanas, puertas...



Tema 35

- Yo leo en un pliego de papel. También dibujo con lápices de colores. Cuando me sale mal tiro el papel a la papelera.
 - Tomo sopa del plato con una cuchara.
 - Todos los pájaros tienen plumas.
-

第三十五课

- 我读一叠文件。我也用彩色铅笔画画。画不好时我就把纸扔到纸篓里。
 - 我从盘子里拿起一把勺子喝汤。
 - 所有鸟都有羽毛。
-

Unit 35

- I read on a sheet of paper. I also draw with colored pencils. When I don't get it right, I put the paper into the waste paper bin.
 - I take some soup from the plate with a spoon.
 - All birds have feathers.
-



Pra, pre, pri, pro, pru.
 Par, per, pir, por, pur.



LECTURA



La ratita presumida para salir al prado se pone preciosa.
 Cuando llega a su casa llama a su primo Paco.
 Paco, date mucha prisa porque tengo que ir a comprar comida.

RESPONDER

1. ¿Dónde sale la ratita presumida?

.....

2. ¿Cómo se pone la ratita presumida?

.....

3. ¿A quién llama la ratita resumida?

.....

4. ¿Cómo se llama el primo de la ratita presumida?

.....

5. ¿Por qué tiene prisa la ratita presumida?

.....

6. ¿Qué tiene que comprar?

.....



a b c d e f g h i j k l m n



ñ o **p** q **r** s t u v w x y z



MI EQUIPO

El _____ de mi equipo ha pedido el precio de un balón en la tienda de _____.

Con el dinero del _____ podremos _____ el balón.

Deportes portero comprar premio



Busca palabras...

P	R	A	D	O	J	L	U	O	P
F	R	E	P	R	E	C	I	O	B
V	C	F	D	E	Y	Z	L	Ñ	Z
F	P	R	E	M	I	O	H	I	D
W	Q	C	K	P	R	I	S	A	B
G	X	O	Z	F	T	R	U	B	L
H	Y	M	V	C	M	N	J	Y	I
G	Y	P	O	R	T	E	R	O	J
Ñ	U	E	G	A	L	J	H	G	U
H	M	A	B	V	C	L	U	G	F

- PRADO
- PRECIO
- PRIMA
- PREMIO
- PRISA
- COMPRA
- PORTERO



Formo frases

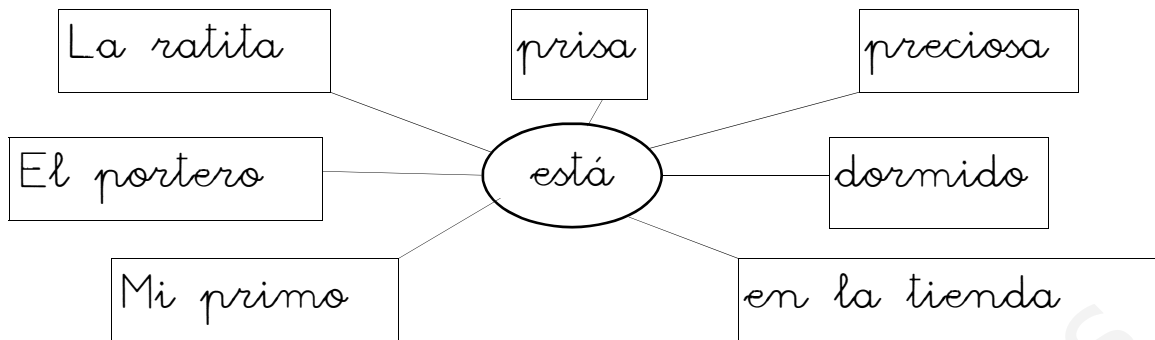

.....

.....

.....

.....

.....

.....

.....

.....

números	
cuarenta	40
cuarenta y uno	41
cuarenta y dos	42
cuarenta y tres	43
cuarenta y cuatro	44
cuarenta y cinco	45
cuarenta y seis	46
cuarenta y siete	47
cuarenta y ocho	48
cuarenta y nueve	49

40 42

41 47

45

44 49

43 48

46



Compro en la tienda... ?

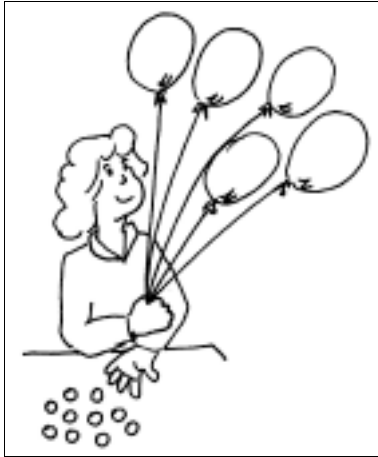

Compro...



Compro...





Tema 36

- La ratita presumida para salir al prado se pone preciosa.
 - Cuando llega a su casa llama a su primo Paco.
 - Paco, date mucha prisa porque tengo que ir a comprar comida.
-

第三十六课

- 自负的小老鼠去草地前把自己打扮得漂漂亮亮的。
 - 到家时她叫她的表兄Paco.
 - Paco,快点,我要去买吃的东西。
-

Unit 36

- The vain little rat does herself up to go out to the country.
 - When she arrives home, she calls her cousin Paco.
 - “Paco, hurry up, because I have to go to buy some food”
-



Tra, tre, tri, tro, tru.
 Tar, ter, tir, tor, tur.



LECTURA

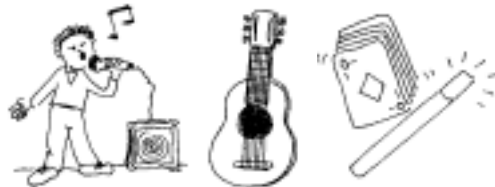

Rafael es una estrella de la canción. Sabe tocar la guitarra, sabe tocar la trompeta y canta muy bien.

También sabe hacer trucos de magia para entretener a sus amigos.

RESPONDER

1. ¿Quién es un estrella de la canción?

.....

2. ¿Qué instrumentos musicales toca Rafael?

.....

3. ¿Cómo canta Rafael?

.....

4. ¿Cómo entretiene Rafael a sus amigos?

.....

5. ¿Sabes tocar un instrumento musical?

.....

6. ¿Cuál?

.....



a b c d e f g h i j k l m n
 ñ o p q r s t u v w x y z

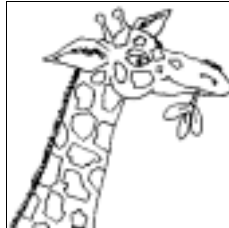

SON UNOS TRAGONES

Hipo y Garrafa son unos _____.
 Están comiendo sin _____, comen a
 todas horas.

La comida _____ de Hipo son las
 _____. La comida preferida de Garrafa
 son los _____.

Tragones trufas parar tréboles preferida



Busca palabras...

T	R	U	F	A	D	K	O	L	Ñ
R	J	E	S	T	R	E	L	L	A
O	K	H	M	B	D	P	S	X	H
M	F	R	S	T	R	E	B	O	L
P	D	L	V	R	X	K	N	M	G
E	F	H	D	O	J	I	L	C	Z
T	F	D	V	F	V	N	C	B	X
A	A	E	Q	E	H	J	V	D	Y
T	R	A	T	O	K	M	B	Ñ	Z
H	D	T	R	U	C	O	F	A	C

- ~~TROMPETA~~
- TRUFA
- TROFEO
- TRÉBOL
- TRATO
- TRUCO
- ESTRELLA



Formo frases

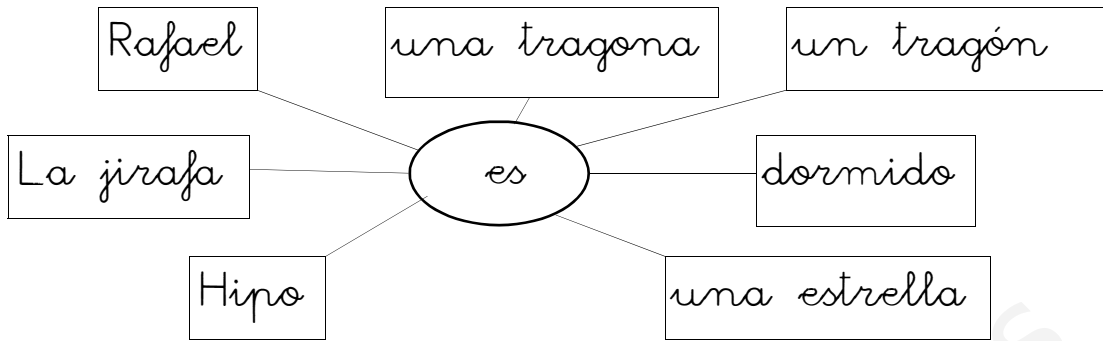

.....

.....

.....

.....

.....

.....

.....

.....

números	
cincuenta	50
sesenta	60
setenta	70
ochenta	80
noventa	90
cien	100
ochenta y seis	86
setenta y siete	77
noventa y ocho	98
cincuenta y nueve	59

50 70

60 77

100

90 49

80 98

86



Cosas que hay en casa...

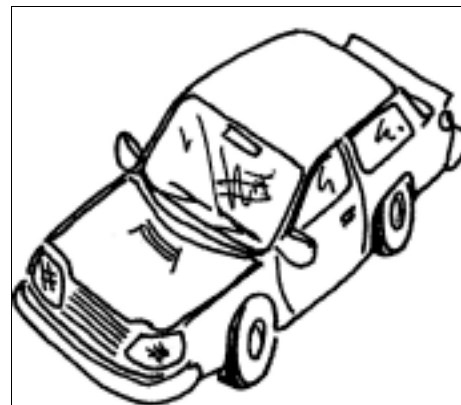
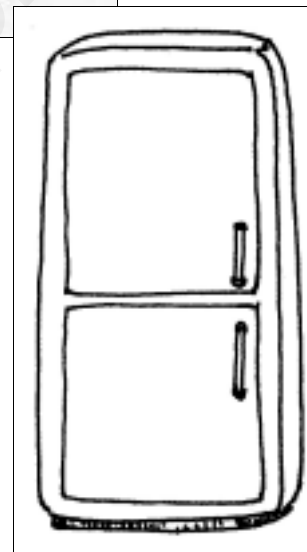
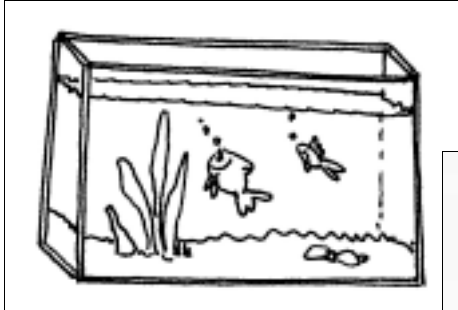



Tema 37

- Rafael es una estrella de la canción. Sabe tocar la guitarra, sabe tocar la trompeta y canta muy bien.
 - También sabe hacer trucos de magia para entretener a sus amigos.
-

第三十七课

- Rafael是一个歌星。他会弹吉它、会吹小号，歌唱得很好。
 - 他还会变魔术逗朋友们开心。
-

Unit 37

- Rafael is a famous singer. He can play the guitar, he can play the trumpet and he can sing-very well.
 - He also knows how to do magic tricks to entertain his friends.
-



Cla, cle, cli, clo, clu.
Cal, cel, cil, col, cul.



LECTURA



El rey Claudio vive en un país de clima templado.

Por primavera los árboles se llenan de hojas verdes y los prados de margaritas.

Las vacas comen tranquilas por el día. Por la noche van a sus casas para dormir.

RESPONDER

1. ¿Quién vive en un país de clima templado?

.....
.....
.....

2. ¿De qué se llenan los árboles?

.....
.....
.....

3. ¿De qué se llenan los prados?

.....
.....
.....

4. ¿Qué hacen las vacas por la mañana?

.....
.....
.....

5. ¿Qué hacen las vacas por la noche?

.....
.....
.....

6. ¿Cómo se llama el rey?

.....
.....
.....



a b **c** d e f g h i j k **l** m n
 ñ o p q r s t u v w x y z

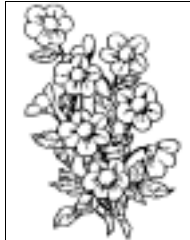
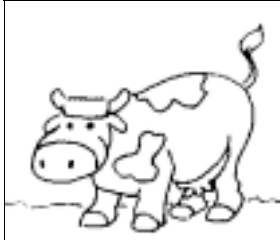

LA VACA CLAUDIA

La vaca _____ todas las _____ da un paseo hasta el _____ para comer margaritas. También le gustan las _____, pero su comida _____ es la hierba verde.

Por la noche camina muy despacio hasta su casa y se queda dormida.

Claudia prado mañanas preferida amapolas



Busca palabras...

H	I	W	S	C	L	A	U	D	I	O
I	L	Ñ	H	L	P	O	I	Y	J	G
E	J	A	D	I	T	E	C	V	L	A
R	D	C	O	M	E	R	V	D	Z	M
B	G	T	D	A	S	E	Ñ	B	V	A
A	F	G	H	J	D	Y	D	A	S	P
D	T	V	B	K	M	N	Y	F	L	O
H	T	M	A	Ñ	A	N	A	G	L	L
G	F	J	B	M	C	H	D	A	S	A
M	A	R	G	A	R	I	T	A	K	A

- ~~CLAUDIO~~
- CLIMA
- COMER
- MAÑANA
- REY
- AMAPOLA
- MARGARITA
- HIERBA



Formo frases

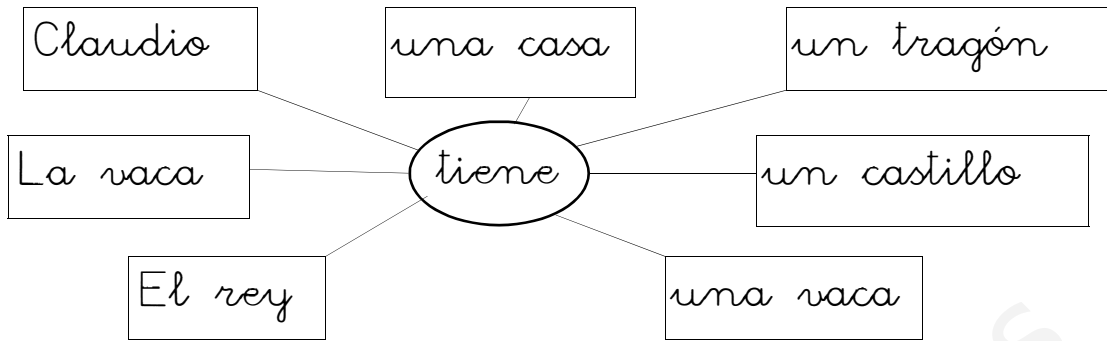

.....

.....

.....

.....

.....

.....

.....

Unir números...

Este es el rey Claudio



¿Jugamos...?





El rey Claudio vive en un país de clima templado.

Por primavera los árboles se llenan de hojas verdes y los prados de margaritas.

Las vacas comen tranquilas por el día. Por la noche van a sus casas para dormir.

La vaca Claudia todas las mañanas da un paseo hasta el prado para comer margaritas. También le gustan las amapolas, pero su comida preferida es la hierba verde.

Por la noche camina muy despacio hasta su casa y se queda dormida.



Handwriting practice area with multiple sets of horizontal lines (solid top and bottom lines, dashed middle line).



Tema 38

- El rey Claudio vive en un país de clima templado
 - Por primavera los árboles se llenan de hojas verdes y los prados de margaritas.
 - Las vacas comen tranquilas por el día. Por la noche van a sus casas para dormir.
-

第三十八课

- 国王Claudio住在一个气候温暖的国家。
 - 春天，树木长满绿色的叶子，草地开满雏菊。
 - 白天，母牛们静静地吃草，晚上，它们回到家里睡觉。
-

Unit 38

- King Claudio lives in a country with a mild weather.
 - The trees fill with green leaves and the fields fill with daisies in spring.
 - The cows eat peacefully during the day. They go home to sleep at night.
-



Cra, cre, cri, cro, cru.
 Car, cer, cir, cor, cur.



LECTURA



A Lulú le gusta la carne cruda.
 Es un perro pequeño y no va a crecer más.
 Su comida preferida son las galletas con miel, por eso se crió fuerte y robusto.

RESPONDER

1. ¿Qué le gusta a Lulú?

.....

2. ¿Lulú es un perro pequeño?

.....

3. ¿Cuál es su comida preferida?

.....

4. ¿Cómo se crió Lulú?

.....

5. ¿A quién le gusta la carne cruda?

.....

6. ¿Tienes un animal en casa? ¿Qué animal es?

.....



a b **c** d e f g h i j k l m n
 ñ o p q **r** s t u v w x y z



MANOLÓN CRECIÓ MUCHO

Mi amigo Manolón _____ mucho. Le
 crecieron las _____, le crecieron los pies.

Le resulta difícil _____ ropa de vestir y
 zapatos.

Ayer le acompañé a la tienda y se compró
 unos _____ de _____.

Manos deportes creció zapatos encontrar



Busca palabras...

E	K	Ñ	O	P	B	F	S	F	G	A
N	C	A	R	N	E	G	X	A	A	Z
C	L	M	N	B	C	M	I	E	L	D
O	F	A	X	Z	B	J	P	G	L	X
N	C	J	C	E	C	R	E	C	E	R
T	G	Ñ	L	O	P	V	R	F	T	Z
R	M	F	X	Z	F	E	R	S	A	S
A	D	Z	A	P	A	T	O	D	H	V
R	D	E	P	O	R	T	E	V	C	G
D	S	R	E	W	L	K	B	F	X	N

~~CARNE~~
 GALLETA
 MIEL
 PERRO
 ZAPATO
 DEPORTE
 CRECER
 ENCONTRAR



Formo frases

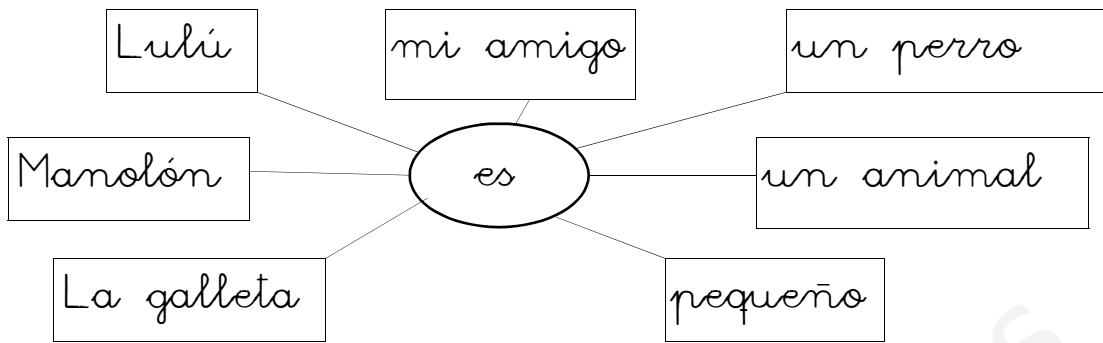

.....

.....

.....

.....

.....

.....

.....

.....

números	
cien	100
doscientos	200
trescientos	300
cuatrocientos	400
quinientos	500
seiscientos	600
setecientos	700
ochocientos	800
novecientos	900
mil	1.000

500 700

600

800

1.000

900 400

200 300

100



¿Qué tiene el carrito de la compra?





Tema 39

- A Lulú le gusta la carne cruda.
 - Es un perro pequeño y no va a crecer más.
 - Su comida preferida son las galletas con miel, por eso se crió fuerte y robusto.
-

第三十九课

- Lulu喜欢吃生肉。
 - 它是一条小狗，不会再长大了。
 - 它最爱吃饼干加蜂蜜，因此，它长得强壮而结实。
-

Unit 39

- Lulú likes raw meat.
 - It is a small dog and it won't grow anymore.
 - Biscuits with honey are its favourite meal; because of it, it grew up strong and robust.
-



Gla, gle, gli, glo, glu.
Gal, gel, gil, gol, gul.



LECTURA



Nuy el esquimal vive en el polo norte. Su casa es un iglú.
Cuando hace buen tiempo le gusta montar en globo y ver las focas desde el cielo.

Tiene una canoa de piel, con ella pasea y va de caza.

RESPONDER

1. ¿Dónde vive Nuy?

.....
.....
.....

2. ¿Qué es un iglú?

.....
.....
.....

3. ¿Qué hace Nuy cuando hace buen tiempo?

.....
.....
.....

4. ¿Qué ve Nuy desde el cielo?

.....
.....
.....

5. ¿De qué está hecha la canoa de Nuy?

.....
.....
.....

6. ¿Qué hace Nuy con su canoa?

.....
.....
.....



a b c d e f **g** h i j k **l** m n
 ñ o p q r s t u v w x y z



EL GLOBO DEL CIRCO

El payaso que estaba en el _____ de la pista del _____ tiró los _____ a la gente.

Todos ríen, todos se lo pasan muy _____.

El _____ sale corriendo de la _____ del circo para traer _____ globos.

Centro, globos, circo, bien, payaso, más, pista.

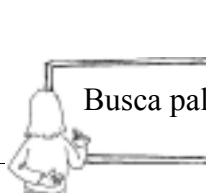

Busca palabras...



y recuerda:

Antes de *p* y *b* se escribe *m* en vez de *n*

E	B	E	T	A	M	B	O	R	T	S
Ñ	O	L	K	N	G	N	F	G	R	F
F	M	V	C	L	I	M	P	I	O	X
O	B	J	B	V	C	X	Z	L	M	O
A	O	H	V	C	X	D	S	A	P	B
F	N	K	G	F	C	Ñ	L	M	E	N
C	A	M	P	A	Ñ	A	B	F	T	C
J	F	X	L	A	M	P	A	R	A	X
C	A	M	P	O	G	C	X	H	Ñ	C
G	D	S	E	S	T	A	M	P	A	D

- TA__BOR
- ESTA__PA
- BO__BON
- CA__PO
- TRO__PETA
- LA__PARA
- LI__PIO
- CA__PAÑA



Formo frases

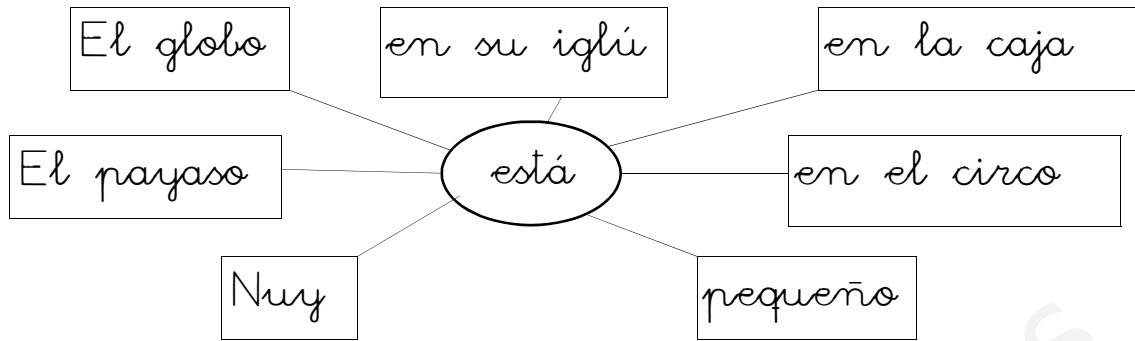

.....

.....

.....

.....

.....

.....

.....

.....

números	
primero	1°
segundo	2°
tercero	3°
cuarto	4°
quinto	5°
sesto	6°
séptimo	7°
octavo	8°
noveno	9°
décimo	10°



Diferentes, iguales..





Tema 40

- Nuy el esquimal vive en el polo norte. Su casa es un iglú.
 - Cuando hace buen tiempo le gusta montar en globo y ver las focas desde el cielo.
 - Tiene una canoa de piel, con ella pasea y va de caza.
-

第四十课

- 爱斯基摩人Nuy住在北极。他的家是一个冰屋。
 - 天气好的时候，他喜欢登上航空球，从天上看那些海豹。
 - 他有一艘皮筏，乘着皮筏去兜风或去打猎。
-

Unit 40

- Nuy the Eskimo lives in the North pole. His house is an igloo.
 - When the weather is good, he likes to go ballooning and to look at the seals from the sky.
 - He has a canoe made with fur. With it, he goes for a ride and goes hunting.
-



Gra, gre, gri, gro, gru.
Gar, ger, gir, gor, gur.



LECTURA



El equipo de Granada tiene la camiseta de color gris.
Esta semana viaja a Grecia para jugar un partido.
El grupo está muy unido y bien preparado para ganar el partido. Todos están muy ilusionados.

RESPONDER

1. ¿De dónde es el equipo?

.....
.....
.....

2. ¿De qué color es la camiseta?

.....
.....

3. ¿Dónde va a jugar un partido?

.....
.....

4. ¿Cómo está el equipo?

.....
.....

5. ¿Para qué van a Grecia?

.....
.....

6. ¿Cómo están todos?

.....
.....



a b c d e f **g** h i j k l m n
 ñ o p q **r** s t u v w x y z

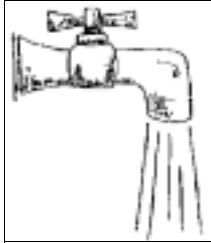

EL GRIFO ESTROPEADO

El _____ está estropeado. No sale _____ por mucho que lo intento.

Mi grifo es de color _____. Le doy a la derecha, le doy a la _____ y sigue sin salir agua.

Llamaré al _____ para que lo _____.

Grifo, izquierda, arregle, agua, gris, fontanero



Busca palabras...

K	G	R	E	C	I	A	H	K	N	M
G	R	I	F	O	D	B	G	R	I	S
I	U	D	B	L	E	H	R	K	F	I
Z	P	E	F	G	R	A	I	D	F	Z
L	O	R	Ñ	H	E	S	E	Z	V	Q
F	Y	E	D	E	C	A	G	U	A	U
F	D	S	Z	R	H	Z	O	S	T	I
S	H	S	A	A	A	T	R	E	S	E
W	A	R	R	E	G	L	A	R	F	Ñ
G	R	A	N	A	D	A	C	D	S	Y

GRANADA
 GRIS
 GRIEGO
 GRECIA
 GRUPO
 GRIFO
 AGUA
 ARREGLAR
 DERECHA



Formo frases

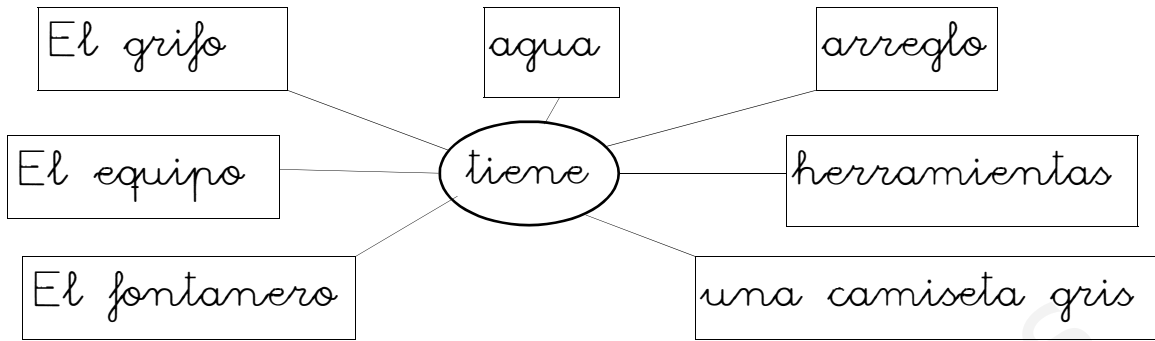

.....

.....

.....

.....

.....

.....

.....

.....

números	
décimo primero	11°
décimo segundo	12°
décimo tercero	13°
décimo cuarto	14°
décimo quinto	15°
décimo sexto	16°
décimo séptimo	17°
décimo octavo	18°
décimo noveno	19°
vigésimo	20°

17° 16°

14° 13°

11° 20°

15° 19°

12° 18°



En mi casa vive...





El equipo de Granada tiene la camiseta de color gris.

Esta semana viaja a Grecia para jugar un partido.

El grupo está muy unido y bien preparado para ganar el partido. Todos están muy ilusionados.

El grifo está estropeado. No sale agua por mucho que lo intento.

Mi grifo es de color gris. Le doy a la derecha, le doy a la izquierda y sigue sin salir agua.

Llamaré al fontanero para que lo arregle



Handwriting practice area with multiple sets of horizontal lines (solid top and bottom lines, dashed middle line).



Tema 41

- El equipo de Granada tiene la camiseta de color gris.
 - Esta semana viaja a Grecia para jugar un partido.
 - El grupo está muy unido y bien preparado para ganar el partido. Todos están muy ilusionados.
-

第四十一课

- Granada队的运动衣是灰色的。
 - 这个星期他们去希腊比赛。
 - 队员们非常团结，为了打赢比赛他们做了充分准备。所有人都对胜利充满希望。
-

Unit 41

- The Granada team wears grey t-shirts.
 - They are going to Greece to play a match this week.
 - The group is very united and well prepared to win the match. They are all very excited.
-



Dra, dre, dri, dro, dru.
Dar, der, dir, dor, dur.



LECTURA



Mi perro ladra como un loco cuando lo llevo al campo.
Al ver a mi hermano Pedro ladra más todavía y mueve más
y más su rabo. Mi madre dice que la va a volver loca.
Cuando llega a casa se queda tranquilo.

RESPONDER

1. ¿Qué hace mi perro cuando lo llevo al campo?

.....
.....
.....

2. ¿Y cuándo ve a mi hermano Pedro?

.....
.....

3. ¿Qué le pasa a mi madre?

.....
.....

4. ¿Dónde llevo al perro?

.....
.....

5. ¿Cuándo se queda tranquilo?

.....
.....

6. ¿Cómo se llama el hermano?

.....
.....



a b c **d** e f g h i j k l m n
 ñ o p q **r** s t u v w x y z

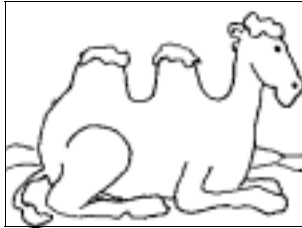

NO ES UN DROMEDARIO

Este que ves aquí _____ no es un _____,
 es un camello. ¿Por qué?

Porque tiene dos _____. No te equivoques, el
 _____ tiene dos jorobas y el dromedario sólo
 una.

Dromedario, camello, arriba, jorobas.



RECUERDA:

Se escriben con mayúsculas los nombres propios de personas, animales o cosas.

Pedro, Lulú, Sevilla.

También se escribe mayúscula al empezar a escribir o después de un punto.

Mi perro ladra como un loco cuando lo llevo al campo.

Al ver a mi hermano Pedro ladra más todavía y mueve más y más su rabo. Mi madre dice que la va a volver loca.



Formo frases

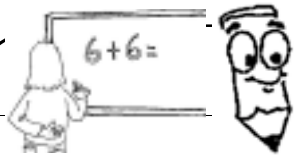
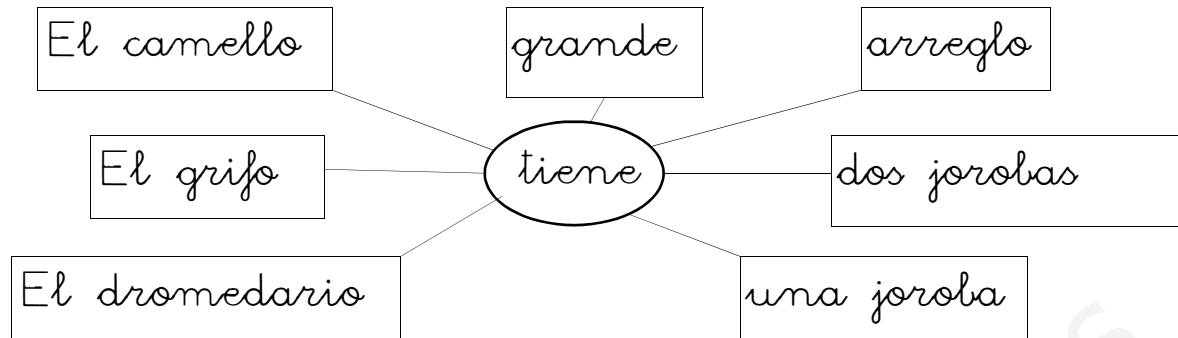

RECUERDA:

Si queremos saber la cantidad de bombones que hay en una caja, los contamos: uno, dos, tres, cuatro, cinco, ...

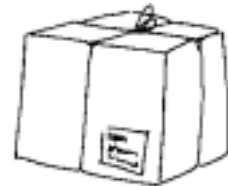

Estos números se llaman NATURALES.

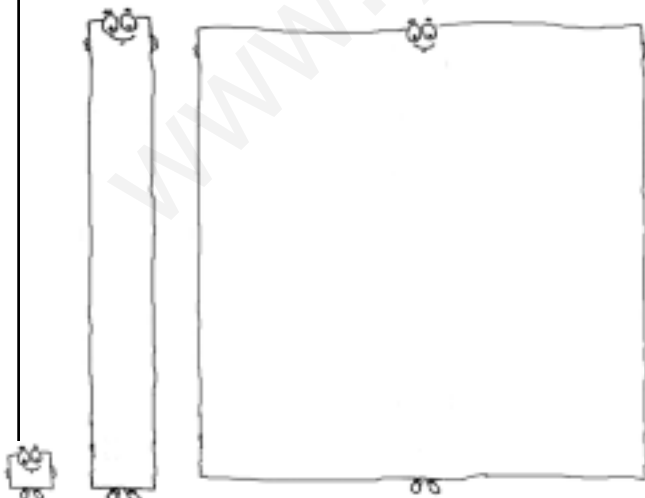

El sistema de numeración que usamos se llama DECIMAL, porque cada 10 UNIDADES forma una DECENA.

Cada 10 DECENAS una CENTENA, ...

unidad decena centena



Los animales ayudan...





Tema 42

- Mi perro ladra como un loco cuando lo llevo al campo.
 - Al ver a mi hermano Pedro ladra más todavía y mueve más y más su rabo. Mi madre dice que la va a volver loca.
 - Cuando llega a casa se queda tranquilo
-

第四十二课

- 每次带狗去郊外它都会兴奋得狂叫。
 - 今天的饭用一只兔子、一些香草和蚯蚓来做。至于喝的她准备了葡萄汁。
 - 吃完饭她坐在壁炉前烤火。
-

Unit 42

- My dog barks as if it was crazy when I take it to the country.
 - When it sees my brother Pedro, he barks even more, and it moves its tail. My mother says that it is driving her crazy.
 - It calms when it arrives home.
-



Fla, fle, fli, flo, flu.
 Fal, fel, fil, fol, ful.



LECTURA



El padre de Flora está flaco.
 Tiene flequillo y bigote.
 Trabaja en una floristería. Vende muchas flores: tulipanes,
 margaritas, rosas, claveles, lilas, crisantemos y muchas más.
 Algunas tardes Flora ayuda a su padre.

RESPONDER

1. ¿Cómo está el padre de Flora?

.....

2. ¿Dónde trabaja el padre de Flora?

.....

3. ¿Qué clase de flores vende?

.....

4. ¿Cuándo ayuda Flora a su padre?

.....

5. ¿Qué tiene el padre de Flora?

.....

6. ¿Qué se vende en la floristería?

.....



a b c d e **f** g h i j k **l** m n
 ñ o p q r s t u v w x y z



EN EL TALLER DE COCHES

En el _____ que hay detrás de mi casa hay dos _____, uno gordo y otro _____.

Los dos son buenos mecánicos y buenas personas.

Todos mis _____ llevan sus _____ al taller cuando tienen una _____.

Taller, flaco, coches, mecánicos, avería, vecinos.



RECUERDA:

Cuidado con las letras:

C, Z, Q.

Son sonidos suaves los siguientes:

Za, ce, ci, zo, zu.

Zapato, cepillo, cielo, zorro, zueco.

Son sonidos fuertes los siguientes:

Ca, que, qui, co, cu.

Casa, queso, quiniela, coche, cuchara



Formo frases

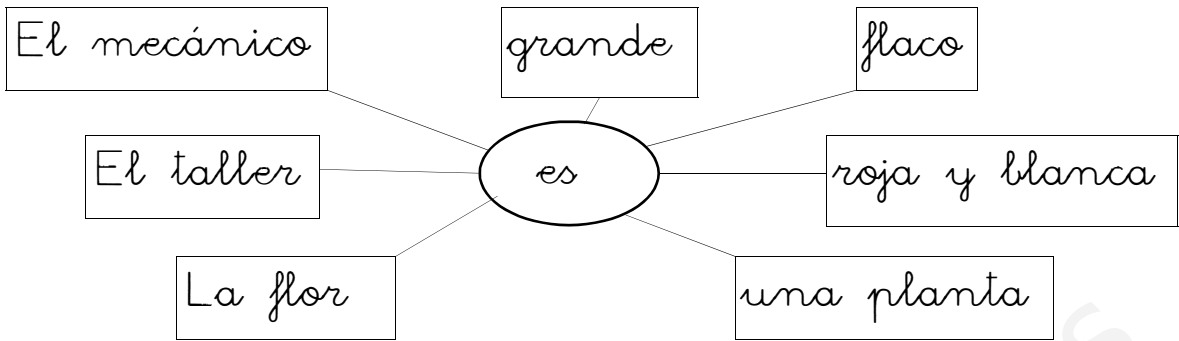

.....

.....

.....

.....

.....

.....

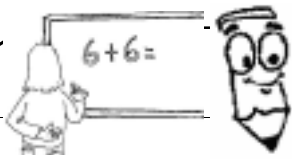

RECUERDA:

Pedro tiene seis rosas rojas...



6

Flora tiene dieciséis plantas...

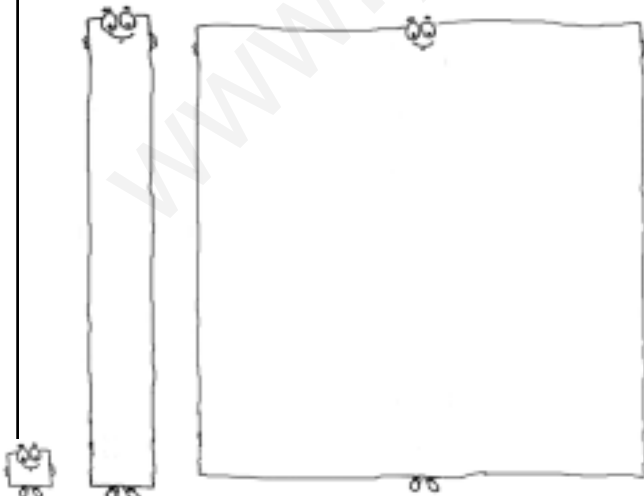

decenas	unidades
	6
1	2

unidad decena centena



Compra y vende...





El padre de Flora está flaco.

Tiene flequillo y bigote.

Trabaja en una floristería. Vende muchas flores: tulipanes, margaritas, rosas, claveles, lilas, crisantemos y muchas más.

Algunas tardes Flora ayuda a su padre.

En el taller que hay detrás de mi casa hay dos mecánicos, uno gordo y otro flaco.

Los dos son buenos mecánicos y buenas personas.

Todos mis vecinos llevan sus coches al taller cuando tienen una avería.



Handwriting practice area with multiple sets of horizontal lines (solid top and bottom lines, dashed middle line).



Tema 43

- El padre de Flora está flaco.
 - Tiene flequillo y bigote.
 - Trabaja en una floristería. Vende muchas flores: tulipanes, margaritas, rosas, claveles, lilas, crisantemos y muchas más.
 - Algunas tardes Flora ayuda a su padre.
-

第四十三课

- Flora的父亲很瘦。
 - 他有刘海和胡子。
 - 他在一家花店工作。他卖很多花：郁金香、雏菊、玫瑰、康耐馨、丁香、菊花和很多其它的花。
 - 有些下午Flora去父亲那里帮忙。
-

Unit 43

- Flora's father is thin.
 - He has a fringed and a mustache.
 - He works in a flower shop. He sells a lot of flowers: tulips, daisies, roses, carnations, lilacs, chrysanthemums and many more.
 - Some afternoons, Flora helps her father.
-



Fra, fre, fri, fro, fru.
Far, fer, fir, for, fur.



LECTURA

azul	blanco	rojo

Colorea mi bandera



Al Norte de España está Francia.

Los colores de su bandera son el azul, el blanco y el rojo.

Los nacidos en Francia se llaman franceses.

Los franceses usan mucho la mantequilla en sus comidas.

También comen mucha fruta fresca.

RESPONDER

1. ¿Qué país está al norte de España?

2. ¿Cómo se llaman los que nacen en Francia?

3. ¿Qué usan los franceses en las comidas?

4. ¿Qué colores tiene la bandera francesa?

5. ¿En qué país has nacido?

6. ¿Qué colores tiene la bandera de España? ¿Y la andaluza?



a b c d e **f** g h i j k l m n
 ñ o p q **r** s t u v w x y z

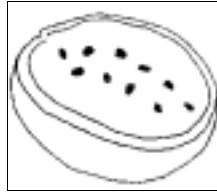
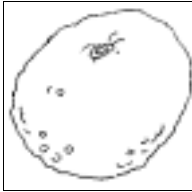
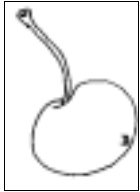

FRUTA FRESCA

Me gusta desayunar con un zumo de _____.

Me gusta _____ la piel de la manzana para que quede luminosa como la _____.

De _____ no hay nada mejor que _____ uvas con un poco de _____.

Naranja, cera, frotar, postre, comer, queso.



RECUERDA:

Cuidado con las letras:

j. g

Son sonidos suaves los siguientes:

Ga, que, qui, go, qu.

Gato, **que**rrero, **qui**ñol, i **go**l!, **qu**samo.

Son sonidos fuertes los siguientes:

Ja, je-ge, ji-gi, jo, ju.

Jarra, **je**fe, **ge**melo, **ji**rafa, **gi**tano, **jo**ya, **ju**ego.



Formo frases

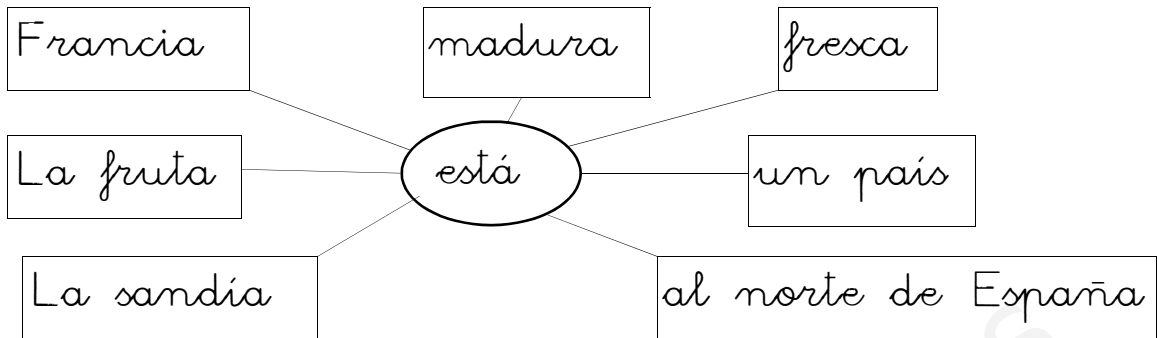

.....

.....

.....

.....

.....

.....

.....

.....

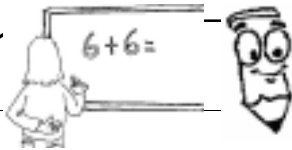

RECUERDA:

Todos los números naturales se pueden escribir utilizando sólo DIEZ SIGNOS: 0, 1, 2, 3, 4, 5, 6, 7, 8, 9.
Estos números se llaman CIFRAS.

Así hay números de una cifra: 1, 2, 3, 4, 5, 6, 7, 8, 9. Estos números tienen UNIDADES.

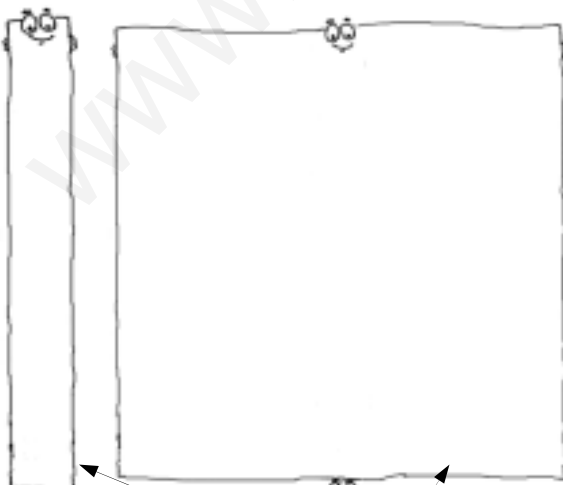

Los de dos cifras:
10, 11, 12, 13, 14, 15...
96, 97, 98, 99. Tienen UNIDADES y DECENAS

Los de tres cifras: 100, 102, 103, 104, 105...
997, 998, 999. Tienen UNIDADES, DECENAS y CENTENAS

unidad decena centena



Deportes.





Tema 44

- Al Norte de España está Francia.
 - Los colores de su bandera son el azul, el blanco y el rojo.
 - Los nacidos en Francia se llaman franceses.
 - Los franceses usan mucho la mantequilla en sus comidas.
 - También comen mucha fruta fresca.
-

第四十四课

- 西班牙的北面是法国。
 - 国旗的颜色是蓝色、白色和红色。
 - 出生在法国的人叫法国人。
 - 法国人吃很多奶油。
 - 他们也吃很多新鲜的水果。
-

Unit 44

- France is located North of Spain.
 - The colors of its flag are blue, white and red.
 - Born in France are called French.
 - French often use butter to cook.
 - They also eat a lot of fresh fruit.
-



Bla, ble, bli, blo, blu.
Bal, bel, bil, bol, bul.



LECTURA

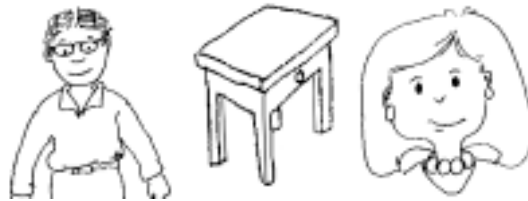

Pablo vive en un pueblo rodeado de robles.

Se puso una blusa blanca y pintó el tablero de la mesa. La blusa acabó toda manchada de pintura.

Llegó la madre a casa y preguntó a Pablo: ¿Qué has hecho con tu blusa blanca?

RESPONDER

1. ¿Dónde vive Pablo?

.....
.....
.....

2. ¿Qué se puso Pablo?

.....
.....
.....

3. ¿Qué pintó Pablo?

.....
.....
.....

4. ¿Cómo acabó la blusa blanca de Pablo?

.....
.....
.....

5. ¿Qué preguntó la madre a Pablo?

.....
.....
.....

6. ¿Qué clase de árboles rodea el pueblo donde vive Pablo?

.....
.....
.....



a **l** c d e f g h i j k **l** m n
 ñ o p q r s t u v w x y z



EL TABLERO DEL PARCHÍS

El _____ del parchís tiene muchos cuadros.
 Es _____ y juegan _____ jugadores, cada jugador tiene cuatro fichas.

Los colores de las fichas son: rojo, _____, _____ y verde. Se juega tirando el _____.

Tablero, cuatro, azul, dado, cuadrado, amarillo



RECUERDA:

No confundas las letras:

ll, y

Escribe siempre ll en todas las palabras que acaben en -illo o -illa.

Silla, bocadillo, cuchillo, toldillo, vaquilla.

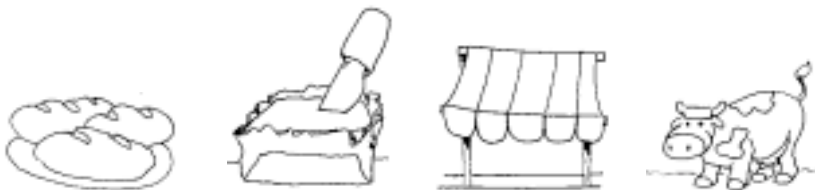



Formo frases

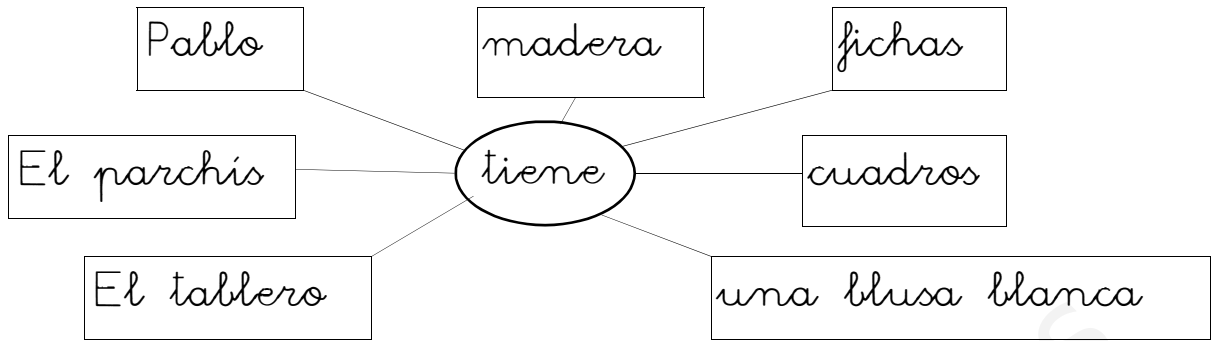

.....

.....

.....

.....

.....

.....

.....

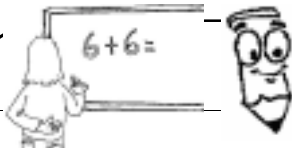

RECUERDA:

Escribo y coloco los números en sus cajas.

87 - ochenta y siete

543 - _____

843 - _____

centena	decena	unidad
	8	7



¿Qué hace?

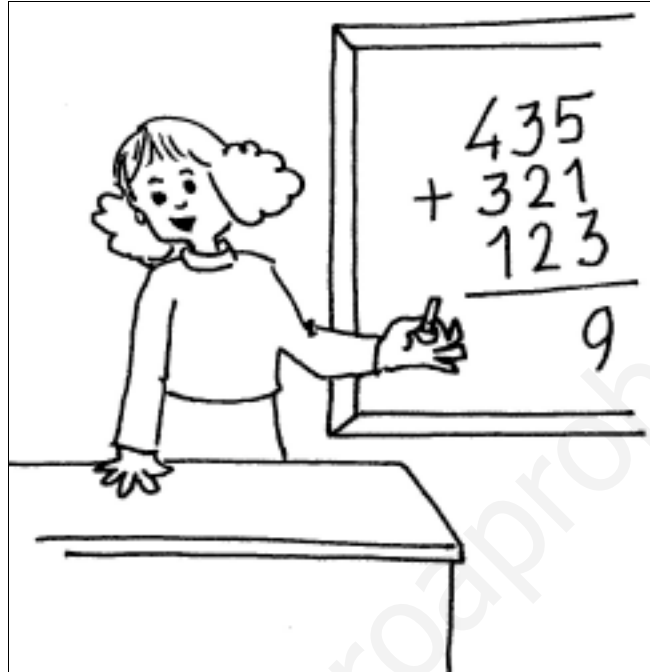



Pablo vive en un pueblo rodeado de robles.
Se puso una blusa blanca y pintó el tablero de la mesa. La blusa acabó toda manchada de pintura.



Llegó la madre a casa y preguntó a Pablo: ¿Qué has hecho con tu blusa blanca?

El tablero del parchís tiene muchos cuadros. Es cuadrado y juegan cuatro jugadores, cada jugador tiene cuatro fichas.

Los colores de las fichas son: rojo, amarillo, azul y verde. Se juega tirando el dado.

Handwriting practice area with multiple sets of horizontal lines (solid top and bottom lines, dashed middle line) for writing.



Tema 45

- Pablo vive en un pueblo rodeado de robles.
 - Se puso una blusa blanca y pintó el tablero de la mesa. La blusa acabó toda manchada de pintura.
 - Llegó la madre a casa y preguntó a Pablo: “¿Qué has hecho con tu blusa blanca?”
-

第四十五课

- Pablo住在一个栎树环绕的镇子里。
 - 他穿上一件白罩衫给桌面刷油漆。结果，罩衫被弄得全是油漆。
 - 他妈妈回家问他：你的白罩衫是怎么弄的？
-

Unit 45

- Pablo lives in a town surrounded by oaks.
 - He put a white shirt on and painted the top of the table. The shirt ended up completely stained with paint.
 - His mother arrived at home and asked Pablo: “What have you done with your white shirt?”
-



Bra, bre, bri, bro, bru.
Bar, ber, bir, bor, bur.



LECTURA

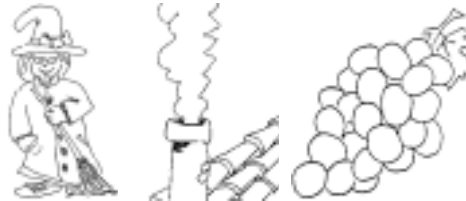

La bruja tiene atada una cabra a la puerta de su casa.
Hoy toca hacer la comida con una liebre, hierbas aromáticas y lombrices, para beber prepara un brebaje con zumo de uvas.
Cuando termina de comer se sienta al abrigo del fuego de su chimenea.

RESPONDER

1. ¿Qué tiene la bruja en la puerta?

.....

.....

2. ¿Con qué hace la comida la bruja?

.....

.....

3. ¿Qué prepara para beber la bruja?

.....

.....

4. ¿Qué hace la bruja cuando termina de comer?

.....

.....

5. ¿Dónde está la cabra?

.....

.....

6. ¿Qué clase de hierbas usa la bruja para hacer la comida?

.....

.....



a **b** c d e f g h i j k l m n
 ñ o p q **r** s t u v w x y z



LA BICICLETA DE BRAULIO

Braulio tiene una _____ nueva. Tiene un
 _____ que hace mucho ruido.

Está todo el _____ dando paseos por su _____.
 Cuando se levanta al día siguiente le duelen los
 _____ y las _____.

Bicicleta, día, timbre, rodillas, calle, hombros.



RECUERDA:

Debes escribir siempre
 B...

En las palabras que empiecen por bu, bus y bur.

buque, buscar, burla.

En todas las palabras que tengan:

bra, bre, bri, bro, bru, y bla, ble, bli, blo, blu.

brazo, sobre, brillo, brocha, bruja...

blanco, cable, ombligo, bloque, blusa...



Formo frases

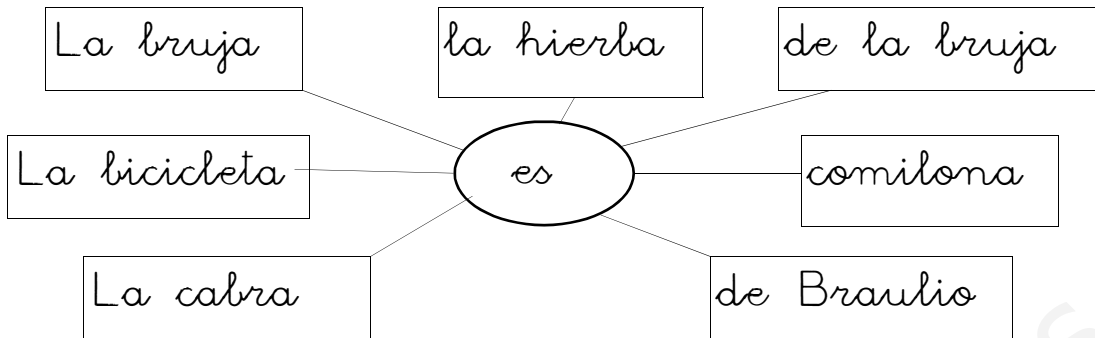

.....

.....

.....

.....

.....

.....

.....

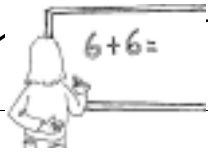

RECUERDA:



Los números de cuatro cifras tienen: UNIDADES, DECENAS, CENTENAS y UNIDADES DE MIL.

Los números de cinco cifras tienen: UNIDADES, DECENAS, CENTENAS, UNIDADES DE MIL y DECENAS DE MIL.

Los números de seis cifras tienen: UNIDADES, DECENAS, CENTENAS, UNIDADES DE MIL, DECENAS DE MIL y CENTENAS DE MIL.

Los números de siete cifras tienen: UNIDADES, DECENAS, CENTENAS, UNIDADES DE MIL, DECENAS DE MIL, CENTENAS DE MIL y UNIDADES DE MILLÓN.

millones			millares o miles			unidades		
centenas	decenas	unidades	centenas	decenas	unidades	centenas	decenas	unidades



¿En qué trabaja?

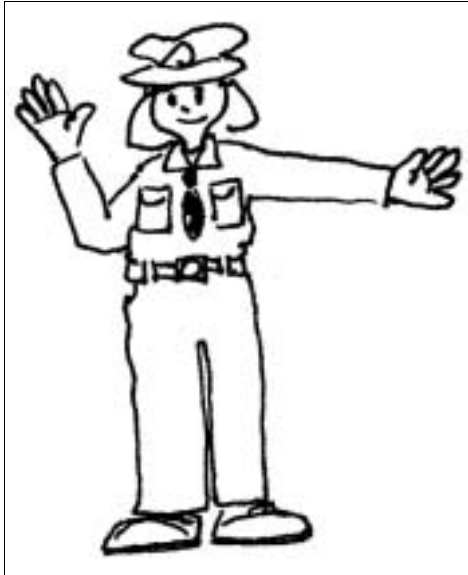



Tema 46

- La bruja tiene atada una cabra a la puerta de su casa.
 - Hoy toca hacer la comida con una liebre, hierbas aromáticas y lombrices, para beber prepara un brebaje con zumo de uvas.
 - Cuando termina de comer se sienta al abrigo del fuego de su chimenea.
-

第四十六课

- 女巫家的门上栓了一只羊。
 - 今天的饭用一只兔子、一些香草和蚯蚓来做。至于喝的她准备了葡萄汁。
 - 吃完饭她坐在壁炉前烤火。
-

Unit 46

- The witch has a goat tied to the door of her house.
 - Today she will cook a hare with aromatic herbs and worms. He prepares a potion with grape juice for drinking.
 - When she has finished eating, she warms up by the fireplace.
-